

TECHNICAL MANUAL
VOLUME 2 OF 2
PART 3 OF 3
MAINTENANCE
DIRECT SUPPORT AND GENERAL SUPPORT LEVEL
2 1/2-TON, 6X6, M44A1 AND M44A2 SERIES TRUCKS
(MULTIFUEL)
TRUCK, CARGO: M35A1,
M35A2, M35A2C, M36A2; TRUCK,
TANK, FUEL: M49A1C, M49A2C; TRUCK, TANK,
WATER: M50A1, M50A2, M50A3; TRUCK, VAN,
SHOP: M109A2, M109A3; TRUCK, REPAIR SHOP:
M185A2, M185A3; TRUCK, TRACTOR: M275A1,
M275A2; TRUCK, DUMP: M342A2; TRUCK,
MAINTENANCE, PIPELINE CONSTRUCTION:
M756A2; TRUCK, MAINTENANCE,
EARTH BORING AND POLESETTING: M764

Chapter 18
Winch, Hoist
and Power
Takeoff Assemblies

Chapter 19
Bumper and
Guards

Chapter 20
Body
Accessory
Items

Chapter 21
Maintenance of
Material used
in Conjunction
with Major
Items

Appendix A
References

NOTE:

THE STYLE OF THIS TM IS
EXPERIMENTAL. IT IS BEING TRIED
BY THE ARMY ONLY ON
A LIMITED BASIS

WARNING

EXHAUST GASES CAN BE DEADLY

Exposure to exhaust gases produces symptoms of headache, dizziness, loss of muscular control, apparent drowsiness, and coma. Permanent brain damage or death can result from severe exposure.

Carbon monoxide occurs in the exhaust fumes of fuel burning heaters and internal combustion engines, and becomes dangerously concentrated under conditions of inadequate ventilation. The following precautions must be observed to insure the safety of personnel whenever fuel burning heater(s) or engine of any vehicle is operated for maintenance purposes or tactical use.

Do not operate heater or engine of vehicle in an enclosed area unless it is adequately ventilated.

Do not idle engine for long periods without maintaining adequate ventilation in personnel compartments.

Do not drive any vehicle with inspection plates or cover plates removed unless necessary for maintenance purposes.

Be alert at all times during vehicle operation for exhaust odors and exposure symptoms. If either are present, immediately ventilate personnel compartments. If symptoms persist, remove affected personnel from vehicle and treat as follows: expose to fresh air; keep warm; do not permit physical exercise; if necessary, administer artificial respiration.

If exposed, seek prompt medical attention for possible delayed onset of acute lung congestion. Administer oxygen if available.

The best defense against exhaust gas poisoning is adequate ventilation.

WARNING

**SERIOUS OR FATAL INJURY TO PERSONNEL MAY RESULT IF
THE FOLLOWING INSTRUCTIONS ARE NOT COMPLIED WITH.**

Dry cleaning solvent is flammable. Do not use near an open flame. Keep a fire extinguisher nearby when solvent is used. Use only in well-ventilated places. Failure to do this may result in injury to personnel and damage to equipment.

Eye shields must be worn when using compressed air. Eye injury can occur if eye shields are not used.

Always wear leather gloves when handling winch cable. Never let cable run through hands. Broken or rusty wires can cause serious injury to personnel.

Cable tensioner is spring-loaded. When winch assembly is raised, the tensioner will drop to unloaded position. Always stand away when raising winch assembly. The cable tensioner can snap back and cause injury to personnel.

Do not let go of winch clutch with a weight suspended from cable. Weight could fall and cause personnel injury and equipment damage.

Always use safety braces when working under dump body. Movement of the control valve or leakage at the hydraulic cylinder line or hose connections can cause the body to drop to the subframe.

WARNING - Cont

Smoking, sparks or open flames are not allowed within 50 feet of work area when working on fuel burning heater systems. Fuel can explode, causing injury to personnel and damage to equipment.

During testing, powerplant heater coolant will be hot. Use caution when working near hot coolant. Severe burns could result.

***TM 9-2320-209-34-2-3**
T.O. 36A12-1B-1092-2-2

TECHNICAL MANUAL
NO. 9-2320-209-34-2-3
TECHNICAL ORDER
NO. 36A12-1B-1092-2-2

DEPARTMENTS OF THE ARMY
AND
THE AIR FORCE
Washington, DC, 20 May 1981

TECHNICAL MANUAL

VOLUME 2 OF 2

PART 3 OF 3

MAINTENANCE

DIRECT SUPPORT AND GENERAL SUPPORT LEVEL
2 1/2-TON, 6X6, M44A1 AND M44A2 SERIES TRUCKS

(MULTIFUEL)

Model		NSN without Winch	NSN with Winch
Truck, Cargo	M35A1	2320-00-542-5633	2320-00-542-5634
	M35A2	2320-00-077-1616	2320-00-077-1617
	M35A2C	2320-00-926-0873	2320-00-926-0875
	M36A2	2320-00-077-1618	2320-00-077-1619
Truck, Tank, Fuel	M49A1C	2320-00-440-3349	2320-00-440-3346
	M49A2C	2320-00-077-1631	2320-00-077-1632
Truck, Tank, Water	M50A1	2320-00-440-8307	2320-00-440-8305
	M50A2	2320-00-077-1633	2320-00-077-1634
	M50A3	2320-00-937-4036	2320-00-937-5264
Truck, Van, Shop	M109A2	2320-00-440-8313	2320-00-440-8308
	M109A3	2320-00-077-1636	2320-00-077-1637
Truck, Repair Shop	M185A2	4940-00-987-8799	4940-00-987-8800
	M185A3	4940-00-077-1638	4940-00-077-1639
Truck, Tractor	M275A1	2320-00-446-2479	
	M275A2	2320-00-077-1640	2320-00-077-1641
Truck, Dump	M342A2	2320-00-077-1643	2320-00-077-1644
Truck, Maintenance, Pipeline Construction	M756A2		2320-00-904-3277
Truck, Maintenance, Earth Boring and Polesetter	M764		2320-00-937-5980

*This manual, together with TM 9-2320-209-34-1, 20 May 1981; TM 9-2320-209-34-2-1, 20 May 1981; and TM 9-2320-209-34-2-2, 20 May 1981, supersedes TM 9-2320-209-34, 30 March 1979.

REPORTING OF ERRORS AND RECOMMENDING IMPROVEMENTS

You can help improve this manual. If you find any mistakes or if you know of a way to improve the procedure, please let us know. Mail your letter, DA Form 2028 (Recommended Changes to Publication and Blank Forms), or DA Form 2028-2 located in the back of this manual direct to: Commander, U.S. Army Tank Automotive Materiel Readiness Command, ATTN: DRSTA-MB, Warren, Michigan 48090. A reply will be furnished to you.

TABLE OF CONTENTS

	Paragraph	Page
CHAPTER 18. WINCH, HOIST, AND POWER TAKEOFF ASSEMBLIES GROUP MAINTENANCE		
Section I. Scope		18-1
Equipment Items Covered	18-1	18-1
Equipment Items Not Covered	18-2	18-1
Section II. Winch and Hoist Assemblies		18-1
Front Winch Repair	18-3	18-1
Preliminary Procedures	18-3a	18-1
Disassembly	18-3b	18-2
Cleaning	18-3c	18-15
Inspection and Repair	18-3d	18-15
Assembly	18-3e	18-21
Rear Winch Removal, Repair, Replacement and Test (Truck M756A2)	18-4	18-34
Preliminary Procedure	18-4a	18-34
Removal	18-4b	18-35
Disassembly	18-4c	18-37
Cleaning	18-4d	18-47
Inspection and Repair	18-4e	18-47
Assembly	18-4f	18-54
Replacement	18-4g	18-66
Test	18-4h	18-68
Rear Winch Removal, Repair, and Replacement (Truck M764)	18-5	18-70
Preliminary Procedures	18-5a	18-70
Removal	18-5b	18-71
Disassembly	18-5c	18-73
Cleaning	18-5d	18-99
Inspection and Repair	18-5e	18-99
Assembly	18-5f	18-113
Replacement	18-5g	18-146
Testing	18-5h	18-148
Rear Winch Drive Chain Removal, Replacement, and Adjustment (Truck M764)	18-6	18-154
Removal	18-6a	18-154
Replacement	18-6b	18-161
Adjustment	18-6c	18-168

TABLE OF CONTENTS-CONT

	Paragraph	Page
Hydraulic Hoist Removal, Repair, and Replacement (Truck M342A2)	18-7	18-169
Preliminary Procedure	18-7a	18-169
Removal	18-7b	18-169
Disassembly	18-7c	18-172
Cleaning	18-7d	18-176
Inspection and Repair	18-7e	18-176
Assembly	18-7f	18-180
Replacement	18-7g	18-186
Hydraulic Hoist Cylinder Assembly Removal, Repair, and Replacement (Truck M342A2)	18-8	18-190
Preliminary Procedures	18-8a	18-190
Removal	18-8b	18-191
Disassembly	18-8c	18-193
Cleaning	18-8d	18-197
Inspection	18-8e	18-197
Repair	18-8f	18-198
Assembly	18-8g	18-198
Replacement	18-8h	18-203
Hydraulic Hoist Pump Assembly Removal, Repair, and Replacement (Truck M342A2)	18-9	18-205
Preliminary Procedures	18-9a	18-205
Removal	18-9b	18-205
Disassembly	18-9c	18-206
Cleaning	18-9d	18-209
Inspection	18-9e	18-209
Repair	18-9f	18-210
Assembly	18-9g	18-210
Replacement	18-9h	18-213
Control Valve Removal and Replacement (Truck M342A2)	18-10	18-214
Preliminary Procedures	18-10a	18-214
Removal	18-10b	18-214
Replacement	18-10c	18-216
Power Divider Input and Rear Output Shaft Oil Seals Removal and Replacement (Truck M764)	18-11	18-218
Removal	18-11a	18-219
Cleaning	18-11b	18-221
Replacement	18-11c	18-222
Power Divider Removal, Repair, and Replacement (Truck M764)	18-12	18-224
Preliminary Procedures	18-12a	18-224
Removal	18-12b	18-225
Disassembly	18-12c	18-230
Cleaning	18-12d	18-245

TABLE OF CONTENTS-CONT

		Paragraph	Page
	Inspection and Repair	18-12e	18-245
	Assembly	18-12f	18-250
	Replacement	18-12g	18-269
Section III.	Power Takeoff Assembly		18-274
	Transmission Front Winch Power Takeoff Removal and Replacement	18-13	18-274
	Preliminary Procedures	18-13a	18-274
	Removal	18-13b	18-275
	Replacement	18-13c	18-276
	Transmission Front Winch Power Takeoff Repair	18-14	18-277
	Transmission Power Takeoff Controls and Linkage Repair	18-15	18-277
	Transmission Transfer Power Takeoff Removal, Repair and Replacement	18-16	18-277
	Preliminary Procedures	18-16a	18-277
	Removal	18-16b	18-278
	Repair	18-16c	18-280
	Replacement	18-16d	18-280
	Transmission Transfer Power Takeoff Controls and Linkage Repair	18-17	18-282
CHAPTER 19.	BUMPER AND GUARDS GROUP MAINTENANCE		
Section I.	Scope		19-1
	Equipment Items Covered	19-1	19-1
	Equipment Items Not Covered	19-2	19-1
Section II.	Bumper, Brackets, Guards, and Protective Devices		19-1
	Front Bumper and Reinforcing Gussets Removal, Repair, and Replacement (All Trucks Without Front Winch)	19-3	19-1
	Preliminary Procedures	19-3a	19-1
	Removal	19-3b	19-2
	Disassembly	19-3c	19-3
	Cleaning	19-3d	19-4
	Inspection and Repair	19-3e	19-4
	Assembly	19-3f	19-5
	Replacement	19-3g	19-6
	Front Bumper and Reinforcing Gussets Removal, Repair and Replacement (All Trucks With Front Winch)	19-4	19-7
	Preliminary Procedure	19-4a	19-7
	Removal	19-4b	19-7
	Cleaning	19-4c	19-9
	Inspection and Repair	19-4d	19-9
	Replacement	19-4e	19-10
	Radiator Brush Guard Removal, Repair, and Replacement	19-5	19-12
	Preliminary Procedures	19-5a	19-12
	Removal	19-5b	19-12

TABLE OF CONTENTS-CONT

	Paragraph	Page
Disassembly	19-5c	19-13
Cleaning	19-5d	19-14
Inspection and Repair	19-5e	19-14
Assembly	19-5f	19-15
Replacement	19-5g	19-16
Vehicle Fuel Tank Support Removal and Replacement (All Trucks Except Trucks M275A1 and M275A2)	19-6	19-17
Preliminary Procedure	19-6a	19-17
Removal	19-6b	19-17
Replacement	19-6c	19-19
Rear Bumperettes Removal and Replacement (All Trucks Except Trucks M275A1, M275A2, and M342A2)	19-7	19-21
Preliminary Procedure	19-7a	19-21
Removal	19-7b	19-21
Replacement	19-7c	19-22
Lamp Support Bracket Removal, Repair, and Replacement (Early Model Trucks)	19-8	19-23
Preliminary Procedures	19-8a	19-23
Removal	19-8b	19-24
Cleaning	19-8c	19-27
Inspection and Repair	19-8d	19-27
Replacement	19-8e	19-28
Lamp Support Bracket Removal, Repair, and Replacement (Late Model Trucks)	19-9	19-31
Preliminary Procedures	19-9a	19-31
Removal	19-9b	19-32
Cleaning	19-9c	19-36
Inspection and Repair	19-9d	19-36
Replacement	19-9e	19-37
CHAPTER 20. BODY ACCESSORY ITEMS GROUP MAINTENANCE		
Section I. Scope		20-1
Equipment Items Covered	20-1	20-1
Equipment Items Not Covered	20-2	20-1
Section II. Canvas and Rubber Items		20-1
Body Cover Repair	20-3	20-1
Body Curtain Repair	20-4	20-1
Water Dispenser Hose Repair	20-5	20-1
Preliminary Procedures	20-5a	20-1
Cleaning	20-5b	20-1
Inspection and Repair	20-5c	20-2
CHAPTER 21. MAINTENANCE OF MATERIAL USED IN CONJUNCTION WITH MAJOR ITEMS		
Section I. Scope		21-1
Equipment Items Covered	21-1	21-1
Equipment Items Not Covered	21-2	21-1
Section II. Winterization Kits		21-1
Hot Water Personnel Heater Kit Installation. .	21-3	21-1

TABLE OF CONTENTS-CONT

	Paragraph	Page
Engine Heater Kit Installation	21-4	
Powerplant Heater Test	21-5	
Preliminary Procedure	21-5a	
Testing	21-5b	21-2
Powerplant Heater Removal, Repair, and Replacement	21-6	21-16
Preliminary Procedures	21-6a	21-16
Removal	21-6b	21-17
Disassembly into Subassemblies	21-6c	21-18
Cleaning and Inspection of Subassemblies.	21-6d	21-29
Assembly.	21-6e	21-51
Replacement	21-6f	21-63
Fuel Burning Personnel Heater Installation.	21-7	21-64
Fuel Burning Personnel Heater Test.	21-8	21-64
Fuel Burning Personnel Heater Removal Repair, Test, and Replacement	21-9	21-64
Preliminary Procedures	21-9a	21-64
Removal	21-9b	21-65
Disassembly	21-9c	21-66
Disassembly, Inspection, Assembly, and Adjustment of Flame Detector Switch	21-9d	21-76
Disassembly, Inspection, Repair, Assembly, and Test of Fuel Control Valve	21-9e	21-79
General Cleaning, Inspection, and Repair	21-9f	21-91
Assembly	21-9g	21-91
Replacement	21-9h	21-101
Van Body Personnel Heater Installation	21-10	21-102
Van Body Personnel Heater Test	21-11	21-102
Van Body Personnel Heater Operating Test (Trucks M109A2, M109A3, M185A2 and M185A3)	21-12	21-102
Primary Van Body Personnel Heater	21-12a	21-103
Secondary Van Body Personnel Heater.	21-12b	21-111
Van Body Personnel Heater Repair	21-13	21-119
Van Body Secondary Heater Repair.	21-14	21-119
Hard Top Closure Kit Installation.	21-15	21-119
Preliminary Procedures	21-15a	21-119
Installation	21-15b	21-119
Hard Top Closure Kit Removal, Repair, and Replacement	21-16	21-120
Removal	21-16a	21-120
Disassembly	21-16b	21-122
Cleaning.	21-16c	21-124
Inspection and Repair	21-16d	21-124
Assembly.	21-16e	21-125
Replacement	21-16f	21-127

TABLE OF CONTENTS-CONT

		Paragraph	Page
	Heater Control Box Assembly		
	Removal, Repair, Replacement, and Test	21-17	21-130
	Removal	21-17a	21-130
	Disassembly	21-17b	21-131
	Inspection and Repair	21-17c	21-134
	Assembly	21-17d	21-134
	Replacement	21-17e	21-138
	Functional Test	21-17f	21-139
	Slave Receptacle Kit Installation	21-18	21-140
Section III.	Deep Water Fording Kit		21-140
	Deep Water Fording Kit Installation	21-19	21-140
	Deep Water Fording Kit Operating Tests	21-20	21-140
	Preliminary Procedure	21-20a	21-140
	Intake Operating Test	21-20b	21-140
	Vent Operating Test.	21-20c	21-143
	Exhaust Operating Test	21-20d	21-144
	Deep Water Fording Kit Removal, Repair, and Replacement	21-21	21-147
	Preliminary Procedures	21-21a	21-147
	Removal	21-21b	21-148
	Cleaning	21-21c	21-160
	Inspection and Repair	21-21d	21-160
	Replacement	21-21e	21-165
	Deep Water Fording Air Pressurizing System Shutoff Valve Removal and Replacement	21-22	21-177
	Removal	21-22a	21-177
	Replacement	21-22b	21-181
	Deep Water Fording Air Pressurizing System Regulator Valve Removal and Replacement.	21-23	21-186
	Preliminary Procedure	21-23a	21-186
	Removal	21-23b	21-186
	Replacement	21-23c	21-188
	Deep Water Fording Air Pressurizing System Hose Removal and Replacement (Trucks M35A1 and M35A2)	21-24	21-191
	Removal	21-24a	21-191
	Replacement	21-24b	21-194
	Deep Water Fording Exhaust Extension Gasket Removal and Replacement	21-25	21-197
	Removal	21-25a	21-197
	Replacement	21-25b	21-198
Section IV.	Special Purpose Kits		21-199
	Decontamination Apparatus Mounting Bracket Installation	21-26	21-199

TABLE OF CONTENTS-CONT

	Paragraph	Page
Decontamination Apparatus Mounting		
Kit Installation	21-27	21-205
A-Frame Kit Installation	21-28	21-205
A-Frame Kit Repair	21-29	21-205
Electric Brake Kit Installation	21-30	21-205
Engine Shipping and Storage		
Container Repair	21-31	21-206
Cleaning	21-31a	21-206
Disassembly	21-31b	21-206
Inspection and Repair	21-31c	21-208
Assembly	21-31d	21-210
Pressure Check	21-31e	21-212
APPENDIX A. REFERENCES.		A-1
INDEX		Index 1

LIST OF TABLES

Number	Title	Page
18-1	Front Winch (Drum Shaft and Bearing) Wear Limits	18-15
18-2	Front Winch (Drum Sliding Clutch) Wear Limits	18-16
18-3	Front Winch (Gearcase and Gearcase Cover Bearings) Wear Limits	18-18
18-4	Front Winch (Drum Lock Poppet Spring and Clutch Control Lever Ball Spring) Wear Limits	18-19
18-5	Front Winch (Drag Brake Spring and End Frame Sleeve) Wear Limits	18-20
18-6	Rear Winch (Drum Shaft and Bearings) Wear Limits	18-49
18-7	Rear Winch (First Reduction Drive Assembly) Wear Limits	18-101
18-8	Rear Winch (Second Reduction Drive Assembly) Wear Limits	18-102
18-9	Rear Winch (Cable Level Winder Assembly) Wear Limits	18-105
18-10	Rear Winch (Drum and Shaft) Wear Limits	18-109
18-11	Rear Winch (Automatic Brake Assembly) Wear Limits	18-112

CHAPTER 18

WINCH, HOIST, AND POWER

TAKEOFF ASSEMBLIES GROUP MAINTENANCE

Section I. SCOPE

18-1. EQUIPMENT ITEMS COVERED. This chapter gives equipment maintenance procedures for the winch and hoist assemblies, and power takeoff assembly for which there are authorized corrective maintenance tasks at the direct and general support maintenance levels.

18-2. EQUIPMENT ITEMS NOT COVERED. All equipment items for which corrective maintenance is authorized at the direct and general support maintenance levels are covered in this chapter.

Section II. WINCH AND HOIST ASSEMBLIES

18-3. FRONT WINCH REPAIR.

TOOLS: No special tools required

SUPPLIES: Solvent, dry cleaning, type II (SD-2), Fed. Spec P-D-680
Clean rags
Gearcase cover gasket
Bearing cap gasket
Sliding clutch key (2)
Brake case gasket
Preformed packing
Brake case cover gasket

PERSONNEL: Two

EQUIPMENT CONDITION: Truck parked, engine off, handbrake set.

a. Preliminary Procedures.

- (1) Remove front winch. Refer to TM 9-2320-209-20.
- (2) Drain front winch. Refer to LO 9-2320-209-12/1.

b. Disassembly.

FRAME 1

1. Take out four screws and washers (1) and take off top tension channel (2).
 2. Take out six screws and washers (3). Take off rear tension channel (4).
- GO TO FRAME 2

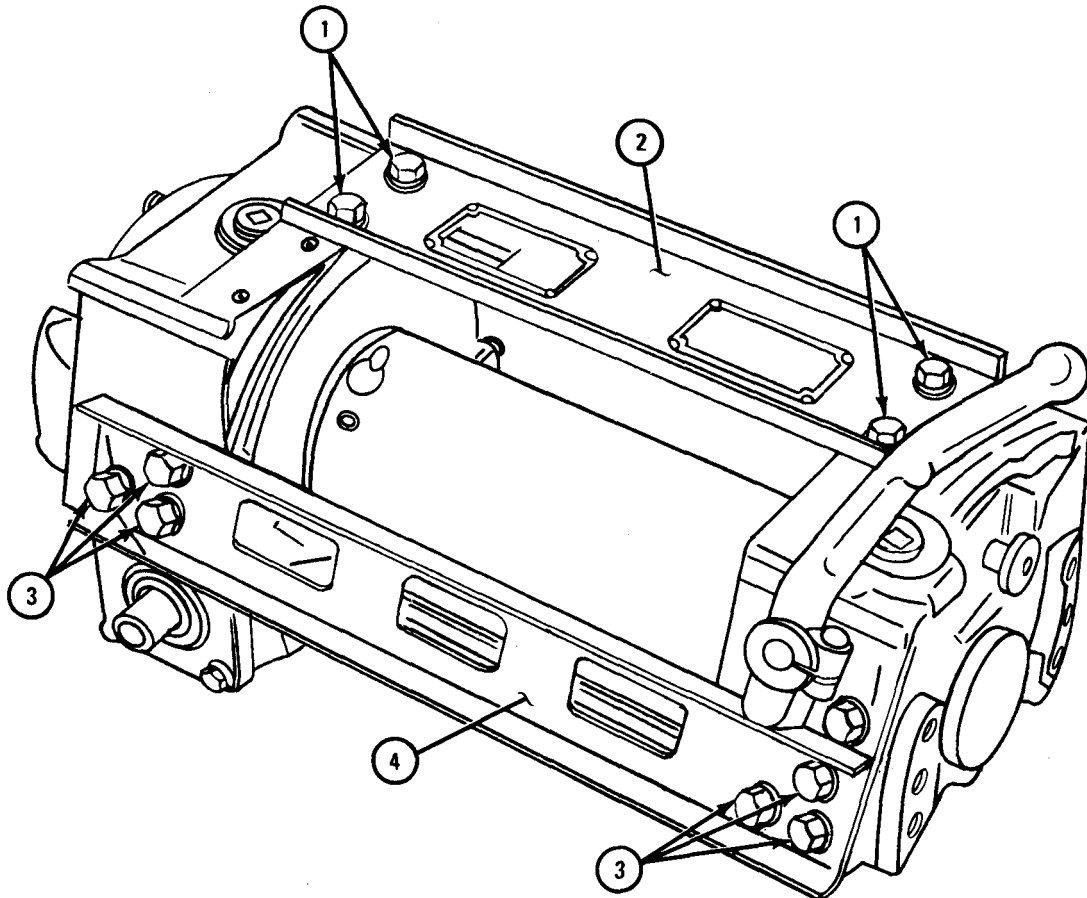

TA 088979

FRAME 2

1. Take out locknut (1) and take off end frame assembly (2).
2. Take out rod (3) from gearcase assembly (4).
3. Loosen two locknuts (5).
4. Take out six screws and washers (6). Take off automatic brake case cover (7).
5. Take off and throw away gasket (8).

GO TO FRAME 3

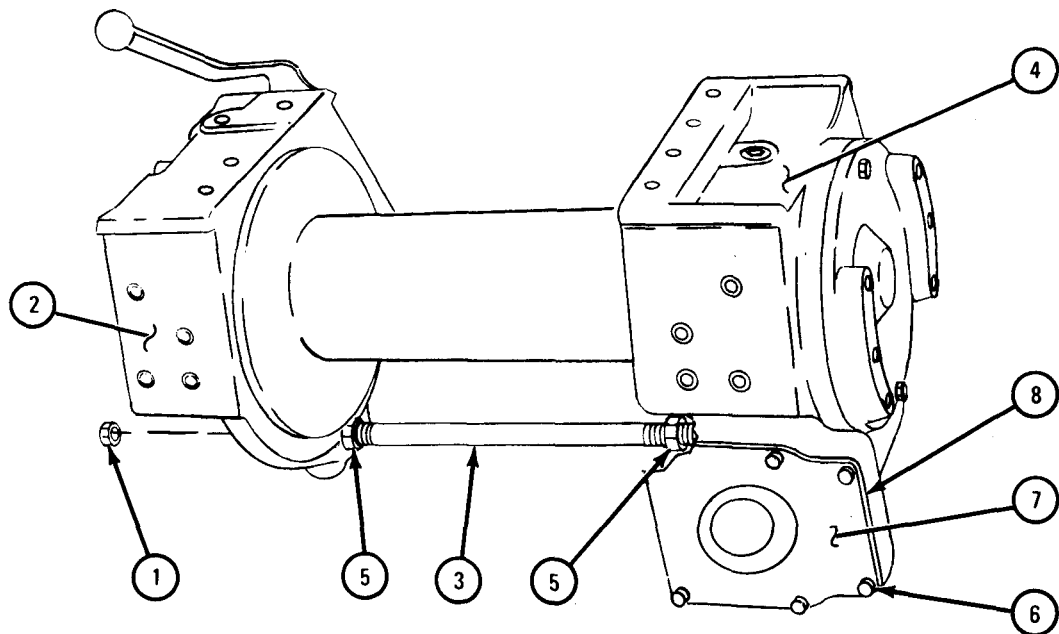

TA 088980

FRAME 3

1. Take out brake adjusting screw (1), washer (2), and preformed packing (3). Throw away preformed packing.
2. Take out adjusting screw spring (4), automatic brake band assembly (5), and brake lining (6).
3. Take out screw and washer (7) and take out brake disk retainer (8).
4. Take out automatic brake disk (9).

GO TO FRAME 4

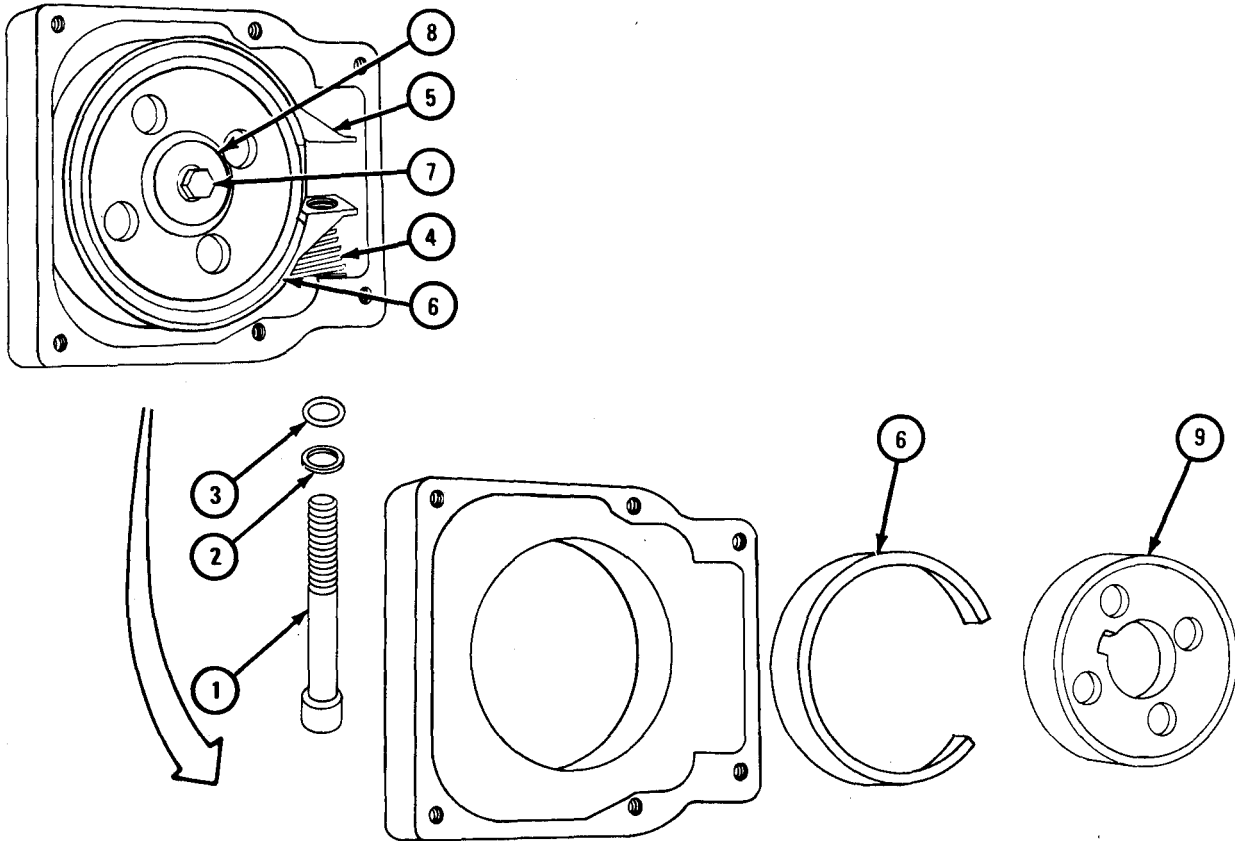

TA 088981

FRAME 4

1. Take out four screws (1) and washers (2) and take off brake case assembly (3).
2. Take off and throw away brake case gasket (4).
3. Check that brake case oil seal (5) is not torn, damaged or leaking. If seal is damaged, take it out and throw it away.
4. Take woodruff key (6) out of shaft (7).

GO TO FRAME 5

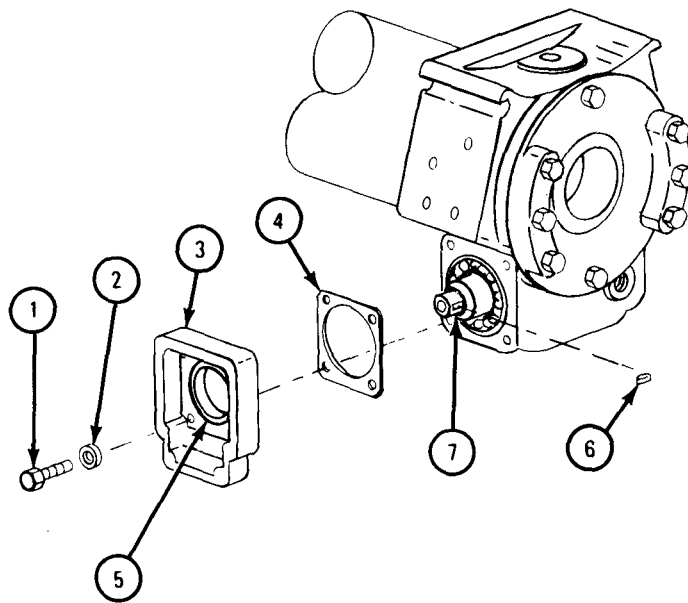

TA 088982

FRAME 5

- Soldier A 1. Take off end frame bearing thrust ring (1) and drum sliding clutch (2).
2. Take out and throw away two sliding clutch keys (3). Take off drum thrust ring (4).
- Soldier B 3. Hold gearcase assembly (5).
- Soldier A 4. Take drum (6) off gearcase assembly (5).
- GO TO FRAME 6

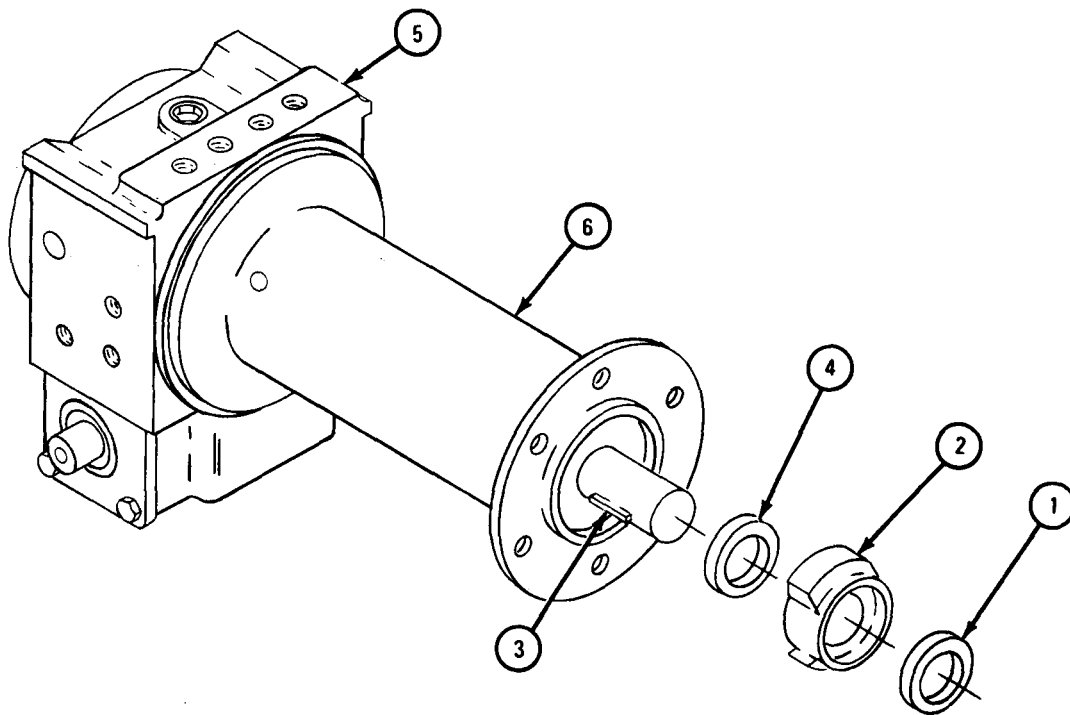

TA 088983

FRAME 6

1. Take out four screws and washers (1) and take off bearing cap (2).
2. Take off and throw away bearing cap gasket (3).
3. Check that bearing cap oil seal (4) is not torn, damaged or leaking. If oil seal (4) is damaged, take it out and throw it away.

GO TO FRAME 7

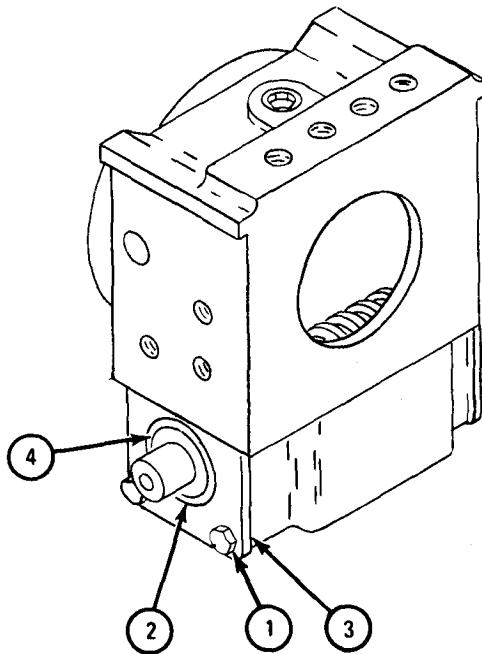

TA 088984

FRAME 7

1. Take out two screws (1), lockwashers (2), and washers (3).

Soldiers A and B 2. Take off gearcase cover (4) and gearcase cover gasket (5). Throw away gasket.

Soldier A 3. Check that gearcase cover bushing type bearing (6) is not cracked, scored or damaged. Check that bearing is within wear limits. Refer to para 18-3d. If bearing is damaged or worn, take out bearing and throw it away.

GO TO FRAME 8

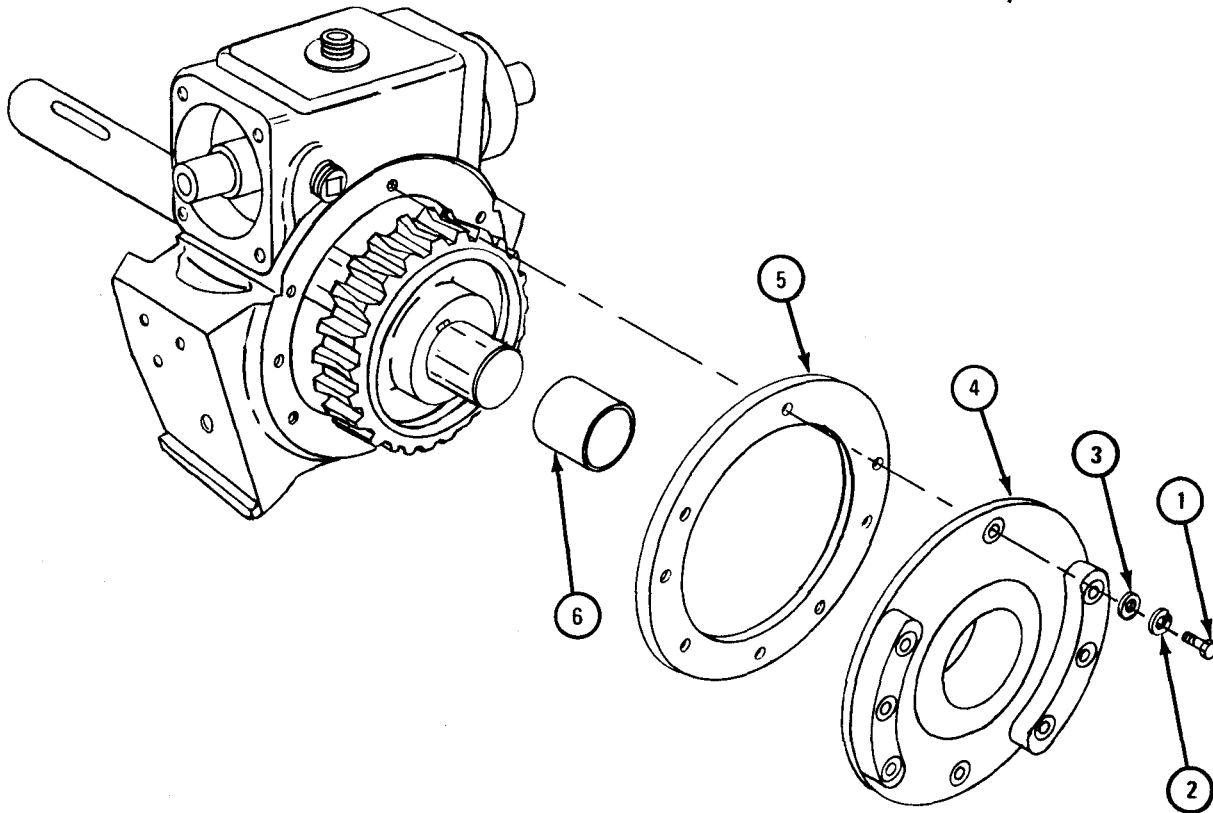

TA 088985

FRAME 8

1. Mount dial indicator on gearcase (1) and check that backlash of drum shaft gear (2) is not more than 0.0625 inch.
2. Using rawhide mallet, tap gear end of drive worm (3) until front ball bearing (4) is free of gearcase (1) and take bearing off drive worm.
- Soldier A 3. Lift drive worm (3) and rear ball bearing (5) until they are clear of drum shaft gear (2).
- Soldier B 4. Take out drum shaft assembly (6).
- Soldier A 5. Take out drive worm (3) with rear ball bearing (5) and using puller, take bearing off drive worm.
6. If backlash of drum shaft gear (2) was more than 0.625 inch, get a new gear.
7. Take out three pipe plugs (7).
8. Check that gearcase bushing type bearing (8) is not cracked, scored or damaged. Check that bearing is within wear limits. Refer to table 18-1.
9. If bearing (8) is damaged or worn, take out bearing and throw it away.

GO TO FRAME 9

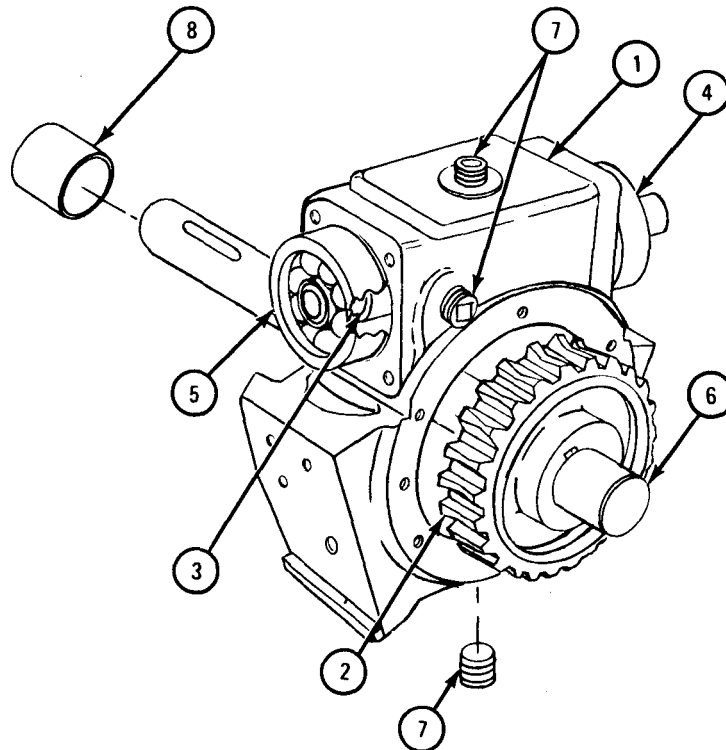

TA 088986

FRAME 9

1. Check that drum gearcase oil seal (1) is not torn, damaged or leaking. If oil seal is damaged, take seal out of drum (2) and throw it away.
2. Check that two drum bushing type bearings (3) are not cracked, scored or damaged. If bearings are damaged, take bearings out of drum (2) and throw them away.
3. Measure two bearings (3) to see that they are within wear limits. Refer to table 18-1. If bearings are not within given limits, throw them away.
4. Take out setscrew (4).

GO TO FRAME 10

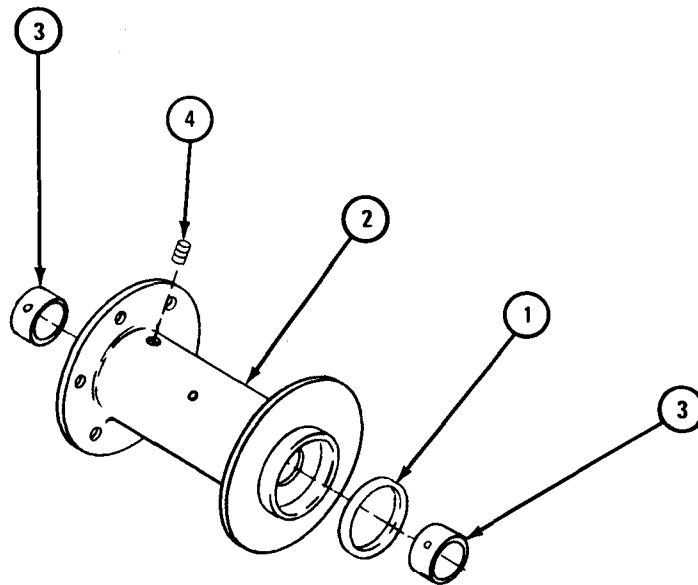

TA 088987

FRAME 10

1. Take out drag brake adjusting screw (1) and take off drag brake assembly (2) and drag brake spring (3).
2. Put drum lock poppet knob (4) in lock position.
3. Punch stake marks on knob (4) and end frame assembly (5).
4. Take nut (6) off drum lock poppet (7) and take knob (4) off poppet.
5. Take off drum lock poppet nut (8) and take out drum lock poppet (7) and drum lock poppet spring (9).

GO TO FRAME 11

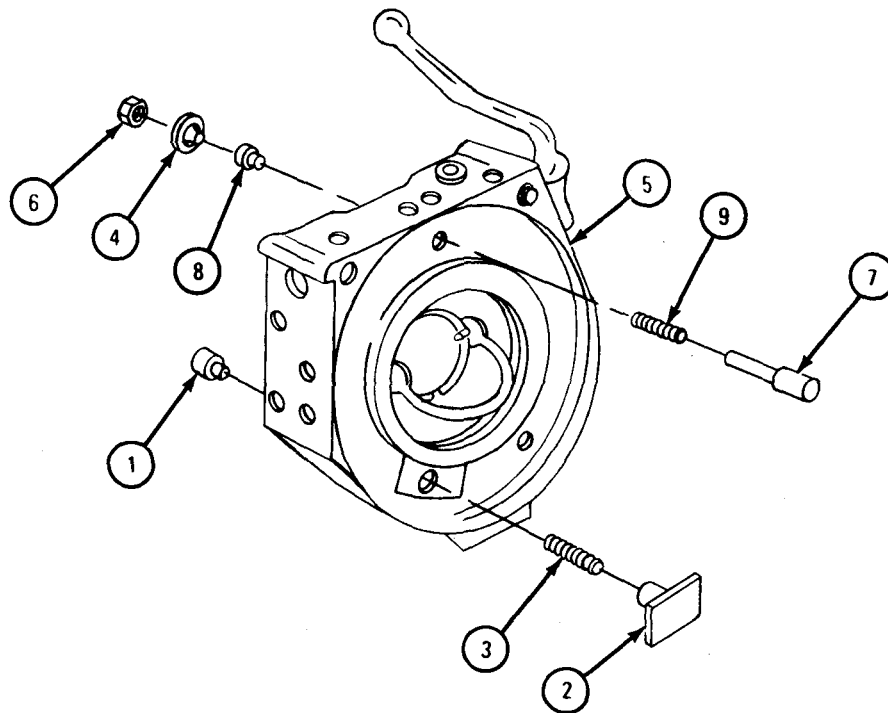

TA 088990

FRAME 11

1. Take out bearing (1) with sleeve assembly (2).
2. Check that bearing (1) is not cracked, scored or damaged. Check that bearing is within wear limits. Refer to table 18-5. If bearing is damaged or worn, take bearing out of sleeve assembly (2) and throw it away.
3. Take out setscrew (3).
4. Take out pipe screw (4) and setscrew (5).
5. Take out screw (6) and washer (7).
6. Check that drum frame end oil seal (8) is not torn, damaged or leaking. If oil seal is damaged, take seal out and throw it away.

GO TO FRAME 12

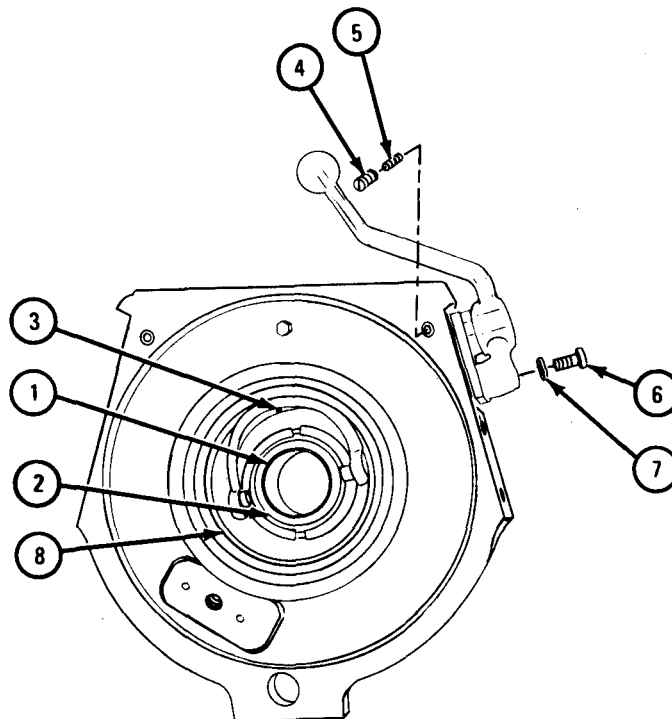

TA 088991

FRAME 12

1. Hold hand under clutch control lever (1) and slowly pull out shifter shaft (2) until control lever ball (3) drops into hand.
2. Take out clutch control lever ball spring (4).
3. Pull lever (1) and shaft (2) until woodruff key (5) is clear of fork (6).
4. Take out woodruff key (5).
5. Take out shaft (2) with lever (1) and take fork (6) out of end frame assembly (7).
6. Take off pawl plate (8).

GO TO FRAME 13

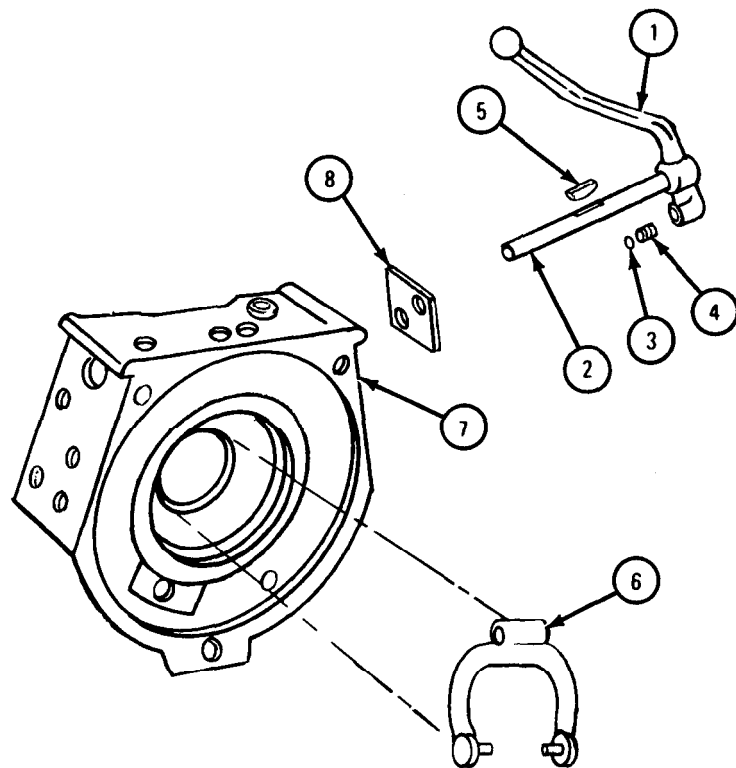

TA 088992

FRAME 13

1. Take out screw (1) and washer (2). Take lever (3) off shaft (4).
2. Take out woodruff key (5) from end of shaft (4).
3. Check that clutch shifter fork shaft oil seal (6) is not torn, damaged or leaking. If oil seal is damaged, take seal out and throw it away.
4. Take out pipe plug filler (7) and pipe plug drain (8).

END OF TASK

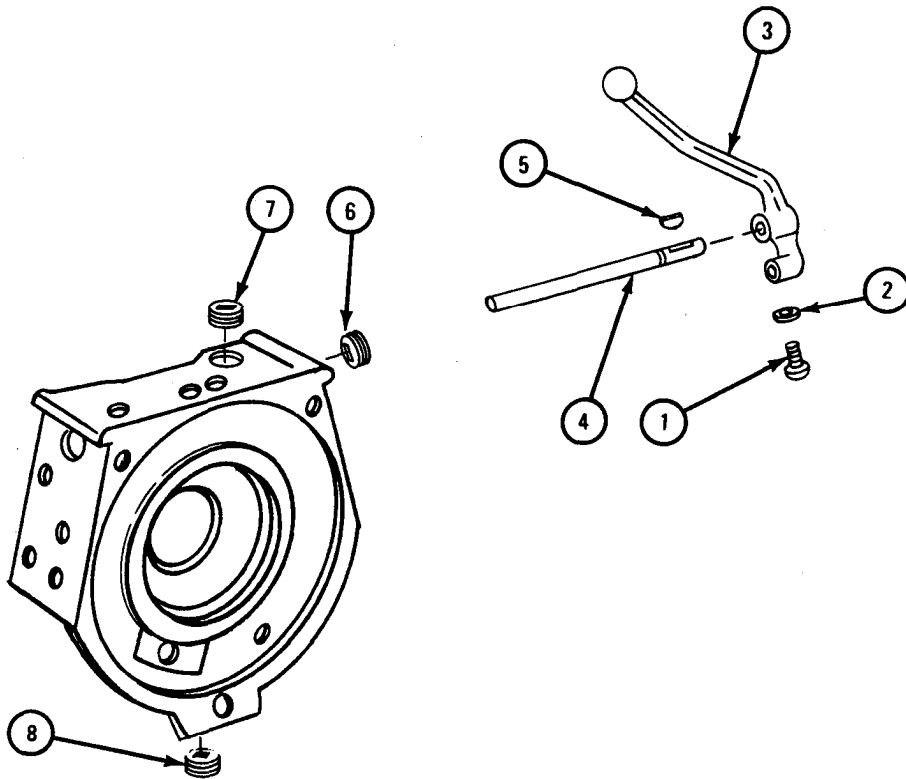

TA 088993

c. Cleaning. There are no special cleaning procedures needed. Refer to cleaning procedures given in Part 1, para 1-3.

d. Inspection and Repair.

FRAME 1

NOTE

Readings must be within limits given in table 18-1. If readings are not within given limits, throw away part and get a new one.

1. Check that drum shaft (1) has no nicks or burrs. Take off nicks and burrs with a honing stone. If more repair is needed, throw shaft away.
2. Measure outer diameter of drum shaft (1).
3. Measure inside diameter of two drum bushing type bearings (2).
4. Check that teeth of drum shaft gear (3) are not broken, chipped or scored. If gear is damaged, get a new one.

GO TO FRAME 2

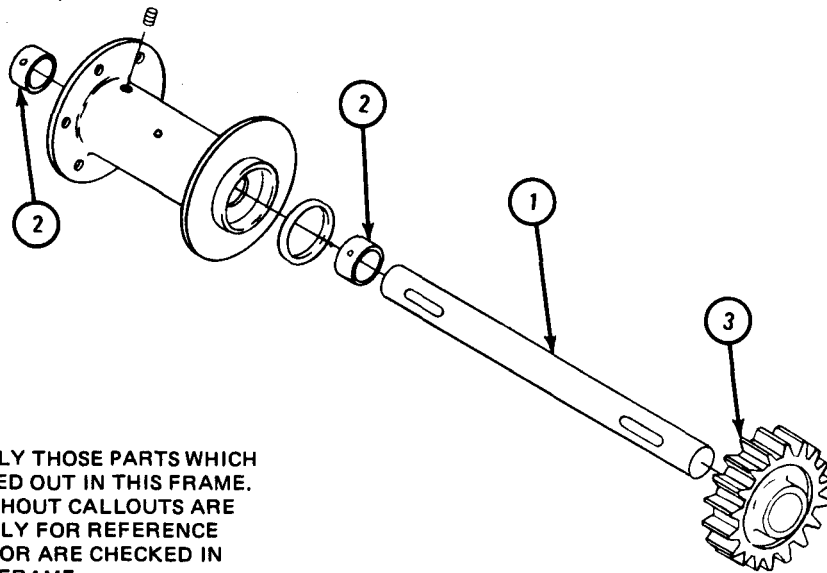

NOTE: CHECK ONLY THOSE PARTS WHICH ARE CALLED OUT IN THIS FRAME. PARTS WITHOUT CALLOUTS ARE SHOWN ONLY FOR REFERENCE PURPOSES OR ARE CHECKED IN ANOTHER FRAME.

TA 088995

Table 18-1. Front Winch (Drum Shaft and Bearing) Wear Limits

Index Number	Item/Point of Measurement	Size and Fit of New Parts (inches)	Wear Limit (inches)
1	Drum shaft outer diameter	1.8730 to 1.8750	1.8710
2	Drum bushing type bearing inside diameter	1.8770 to 1.8800	1.8950

FRAME 2

N T E

Readings must be within limits given in table 18-2. If readings are not within given limits, throw away part and get a new one.

1. Check that drum assembly (1) has no chips or cracks. If drum assembly is damaged, get a new one.
2. Check that surface of clutch shifter fork (2) where it meets drum sliding clutch (3) is not broken or damaged. If shifter fork is damaged, get a new one.
3. Check that surface clutch (3) where it meets drum assembly is not broken or damaged. If clutch is damaged, get a new one.
4. Check that thrust ring (4) has no cracks. If thrust ring is damaged get a new one.
5. Measure inside diameter of drum sliding clutch (3).

GO TO FRAME 3

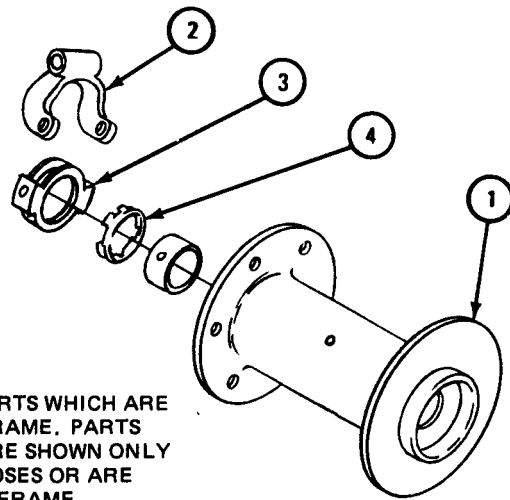

NOTE: CHECK ONLY THOSE PARTS WHICH ARE CALLED OUT IN THIS FRAME. PARTS WITHOUT CALLOUTS ARE SHOWN ONLY FOR REFERENCE PURPOSES OR ARE CHECKED IN ANOTHER FRAME.

TA 088996

Table 18-2. Front Winch (Drum Sliding Clutch) Wear Limits

Index Number	Item/Point of Measurement	Size and Fit of New Parts (inches)	Wear Limit (inches)
3	Drum sliding clutch inside diameter	1.8870 to 1.8890	1.9040

FRAME 3

1. Check that surface of automatic brake disk (1) is not scored or damaged. If automatic brake disk is damaged, get a new one.
2. Check that automatic brake band lining (2) is not worn down to rivets and that it is not oil soaked. If rivets show or if lining is oil soaked, get a new lining.
3. Check that automatic brake case (3) is not cracked or damaged. If brake case is damaged, get a new one.
4. Check that adjusting screw spring (4) has no cracks, flaws or damage. If spring is damaged, get a new one.
5. Check that free length of adjusting screw spring (4) is 1 1/2 inches.

GO TO FRAME 4

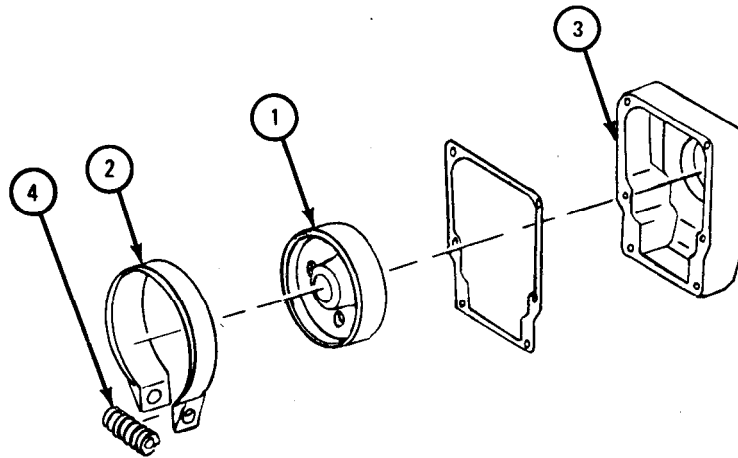

NOTE: CHECK ONLY THOSE PARTS WHICH ARE CALLED OUT IN THIS FRAME. PARTS WITHOUT CALLOUTS ARE SHOWN ONLY FOR REFERENCE PURPOSES OR ARE CHECKED IN ANOTHER FRAME.

TA 088997

FRAME 4

NOTE

Readings must be within limits given in table 18-3. If readings are not within given limits, throw away part and get a new one.

1. Check that gearcase (1) and gearcase cover (2) have no cracks, nicks, burrs or damaged threads. Take off raised metal with a fine mill file, retap damaged threads, and weld cracks. Refer to TM 9-237. If more repair is needed, get a new part.
2. Check that drive worm (3) is not nicked, scored or damaged. If drive worm is damaged, get a new one.
3. Check that drive worm front and rear ball bearings (4) have no chips, roughness or flat spots. If ball bearings are damaged, get new ones. Put a coat of engine lubricating oil on ball bearings to keep out dust and dirt.
4. Check that bearing cap (5) and its gasket surface are not cracked, nicked or burred. Take off raised metal with a fine mill file. If more repair is needed, get a new part.
5. Measure inside diameter of gearcase bushing type bearing (6) and gearcase cover bushing type bearing (7).

GO TO FRAME 5

NOTE: CHECK ONLY THOSE PARTS WHICH ARE CALLED OUT IN THIS FRAME. PARTS WITHOUT CALLOUTS ARE SHOWN ONLY FOR REFERENCE PURPOSES OR ARE CHECKED IN ANOTHER FRAME.

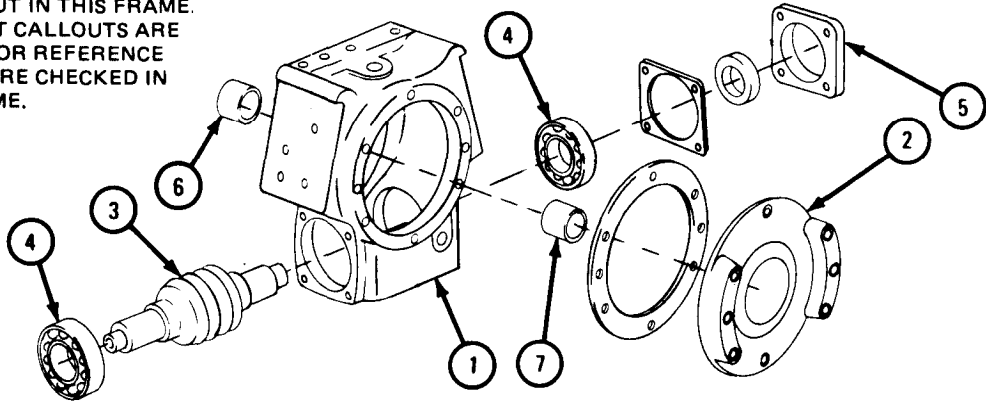

TA 088998

Table 18-3. Front Winch (Gearcase and Gearcase Cover Bearings) Wear Limits

Index Number	Item/Point of Measurement	Size and Fit of New Parts (inches)	Wear Limit (inches)
6	Gearcase bushing type bearing inside diameter	1.8770 to 1.8800	1.8880
7	Gearcase cover bushing type bearing inside diameter	1.8770 to 1.8800	1.8880

FRAME 5

NOTE

Readings must be within limits given in table 18-4. If readings are not within given limits, throw away part and get a new one.

1. Check that drum lock poppet (1) and drum lock poppet knob (2) have no cracks or other damage. If parts are damaged, get new ones.
2. Measure free length of drum lock poppet spring (3). Measure length of spring when under load of 17.3 pounds.
3. Check that clutch shifter fork shaft (4) and clutch control lever (5) have no cracks or other damage. If parts are damaged, get new ones.
4. Check that clutch control lever ball (6) and clutch control lever ball spring (7) are not grooved, cracked or damaged. If parts are damaged, get new ones.
5. Measure free length of clutch control lever ball spring (7). Measure length of ball spring when under a load of 45 pounds.
6. Check that end frame (8) and rear channel (9) are not cracked or damaged. If parts are damaged, get new ones.

GO TO FRAME 6

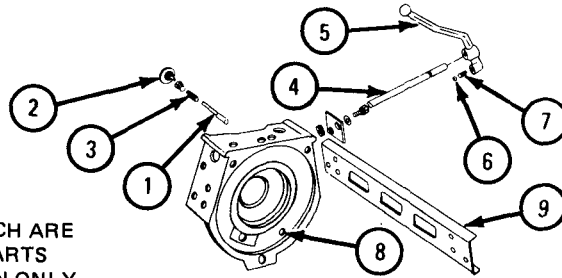

NOTE: CHECK ONLY THOSE PARTS WHICH ARE CALLED OUT IN THIS FRAME. PARTS WITHOUT CALLOUTS ARE SHOWN ONLY FOR REFERENCE PURPOSES OR ARE CHECKED IN ANOTHER FRAME.

TA 088999

Table 18-4. Front Winch (Drum Lock Poppet Spring and Clutch Control Lever Ball Spring) Wear Limits

Index Number	Item/Point of Measurement	Size and Fit of New Parts (inches)	Wear Limit (inches)
3	Drum lock poppet spring free length	1 29/32	None
3	Drum lock poppet spring length at 17.3 pounds compression	1	None
7	Clutch control lever ball spring free length	0.6875	None
7	Clutch control lever ball spring at 45 pounds compression	0.4800	None

FRAME 6

NOTE

Readings must be within limits given in table 18-5. If readings are not within given limits, throw away part and get a new one.

1. Check that drag brake assembly brake lining (1) is not worn down to rivets or oil soaked. If rivets show or if brake lining is oil soaked, get a new one.
2. Check that drag brake spring (2) has no cracks or other damage. If drag brake spring is damaged, get a new one.
3. Measure free length of drag brake spring (2). Measure length of drag brake spring when under a load of 48 pounds.
4. Measure inside diameter of end frame sleeve bushing type bearing (3).
5. Check that drum frame end oil seal (4) is not torn, damaged or leaking. If seal is damaged, take it out and get a new one.

END OF TASK

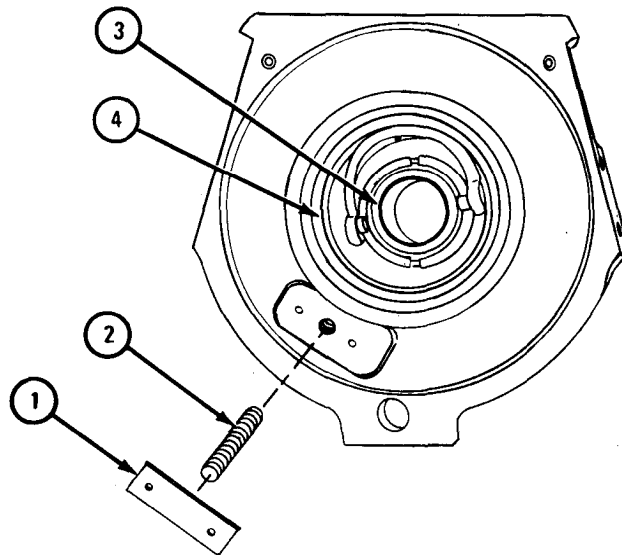

TA 089000

Table 18-5. Front Winch (Drag Brake Spring and End Frame Sleeve) Wear Limits

Index Number	Item/Point of Measurement	Size and Fit of New Parts (inches)	Wear Limit (inches)
2	Drag brake spring free length	2	None
2	Drag brake spring length at pounds compression	1 11/16	None
3	End frame sleeve bushing type bearing inside diameter	1.8770 to 1.8880	None

e. Assembly.

FRAME 1

1. Put in drain pipe plug (1) and filler pipe plug (2).
2. Put in clutch shifter fork shaft oil seal (3).
3. Put woodruff key (4) in end of shaft (5).
4. Put lever (6) over woodruff key (4) on shaft (5). Put in screw (7) and washer (8).

GO TO FRAME 2

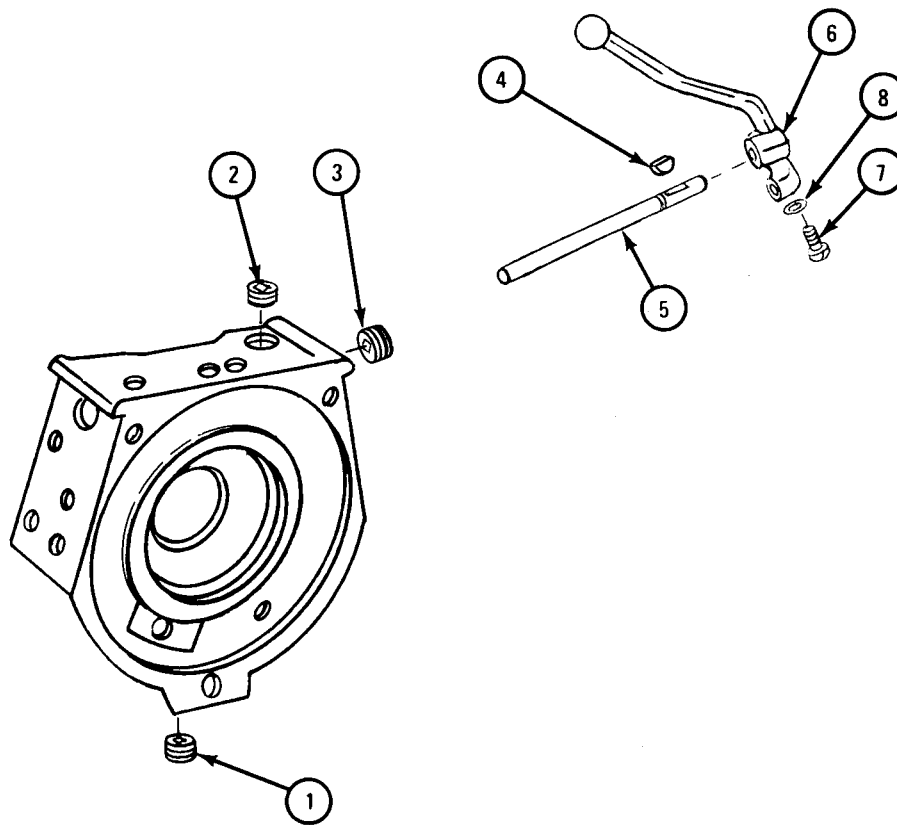

TA 089001

FRAME 2

1. Put pawl plate (1) on end frame assembly (2).
2. Put shaft (3) in end frame assembly (2).
3. Put woodruff key (4) in shaft (3).
4. Put fork (5) in end frame assembly (2) and put in shaft (3) with lever (6).
5. Put in clutch control lever ball spring (7) and clutch control lever ball (8).
6. Put in screw (9) and washer (10).

GO TO FRAME 3

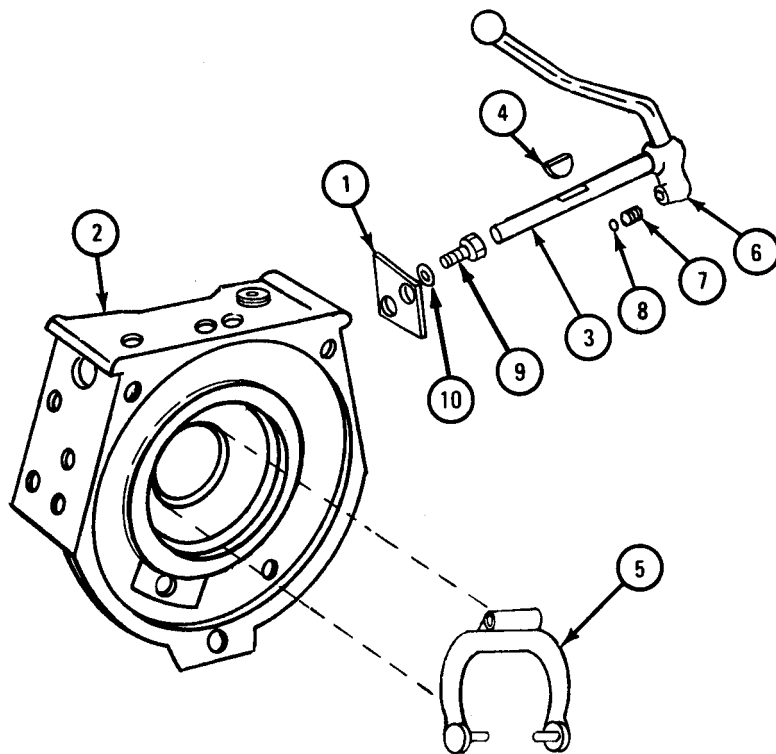

TA 089002

FRAME 3

1. Put in setscrew (1) and pipe screw (2).
2. Put in setscrew (3).
3. Put bearing (4) in sleeve assembly (5) and put bearing and sleeve assembly into end frame assembly (6).
4. Put in drum frame end oil seal (7).

GO TO FRAME 4

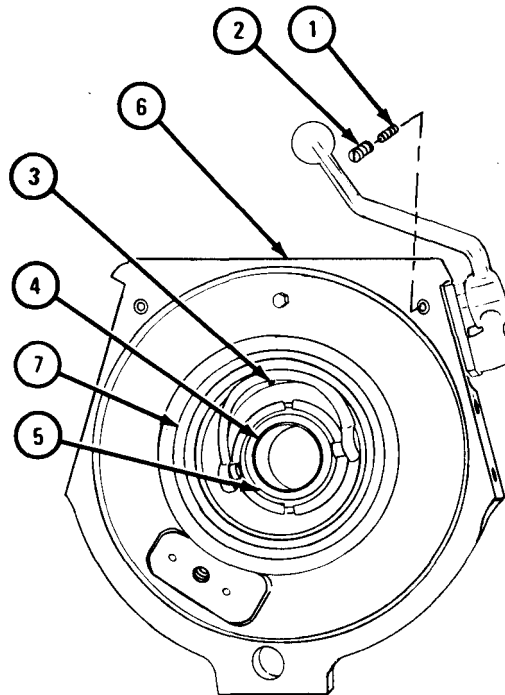

TA 089003

FRAME 4

1. Put in drum lock poppet spring (1) and drum lock poppet (2) and put on drum lock poppet nut (3).
2. Put drum lock poppet knob (4) on poppet (2), alining stake and put on nut (5).
3. Put in drag brake spring (6), drag brake assembly (7), and drag brake adjusting screw (8).

GO TO FRAME 5

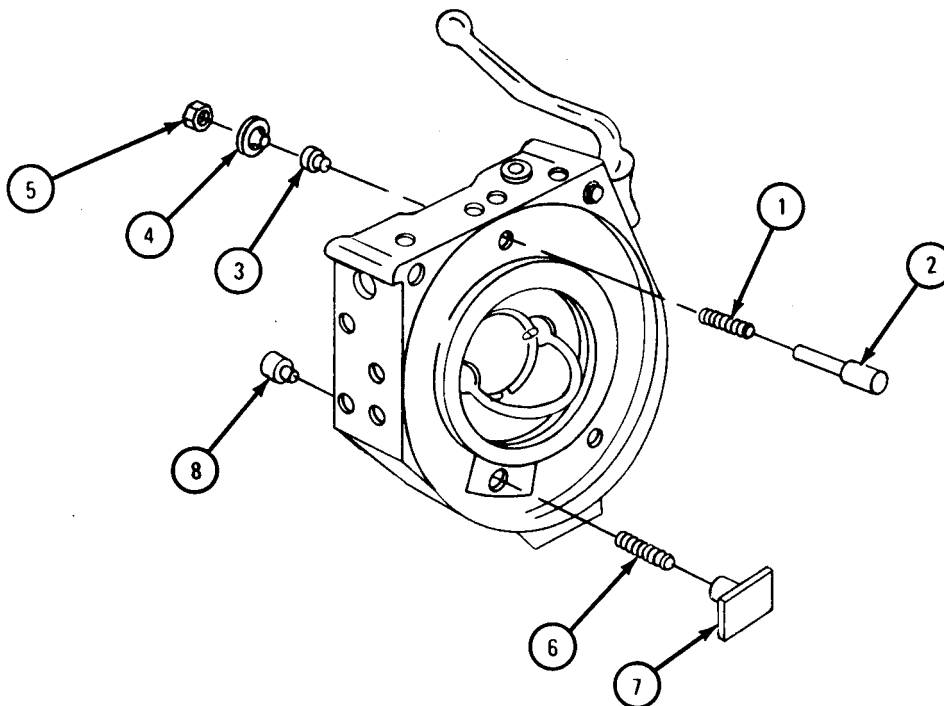

TA 089004

FRAME 5

1. Put setscrew (1) in drum (2).
2. Put in two drum bushing type bearings (3).
3. Put in drum gearcase oil seal (4).

GO TO FRAME 6

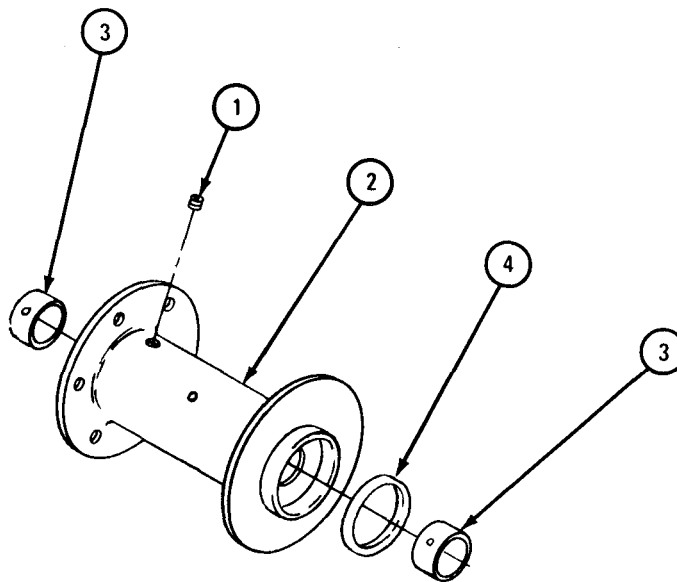

TA 089005

FRAME 6

1. Put in gearcase bushing type bearing (1) and put in three pipe plugs (2).
2. Press rear ball bearing (3) onto worm gear (4) and put worm gear and bearing into housing (5).

Soldier A 3. Hold worm gear (4) so that drum shaft assembly (6) and drum shaft gear (7) can be put in.

Soldier B 4. Put in drum shaft assembly (6) and drum shaft gear (7).

5. Mesh worm gear (4) with drum shaft gear (7) and put on front ball bearing (8).

GO TO FRAME 7

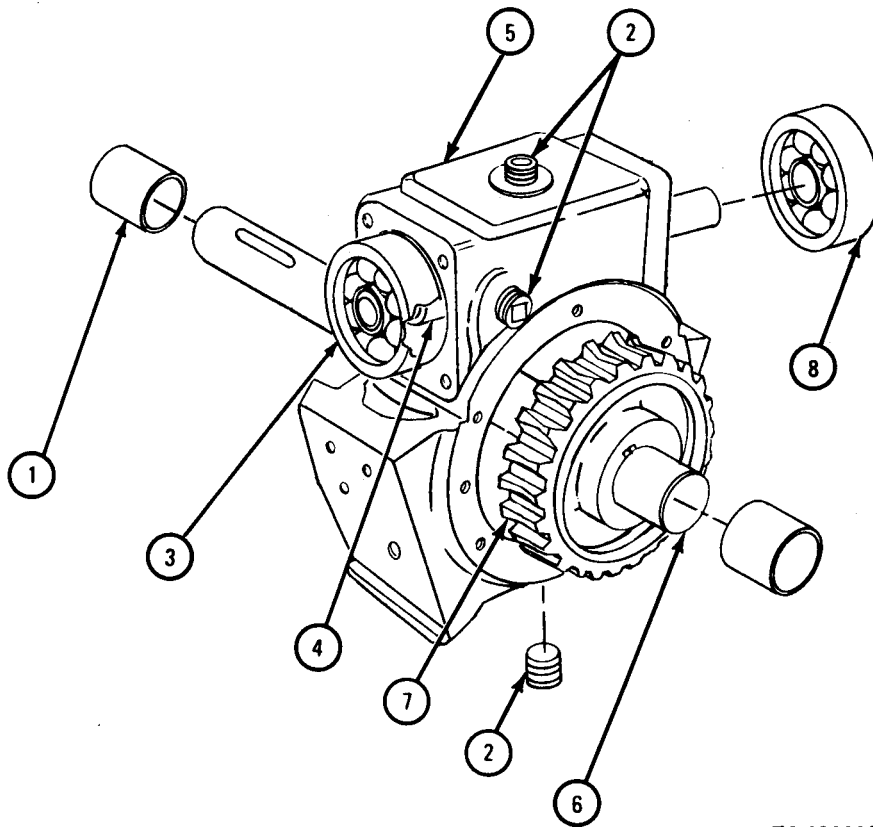

TA 089006

FRAME 7

1. Put gearcase cover bushing type bearing (1) in gearcase cover (2).
- Soldiers A and B
2. Put gasket (3) and gearcase cover (2) on gearcase (4).
- Soldier A
3. Put in two washers (5), lockwashers (6), and screws (7).
- GO TO FRAME 8

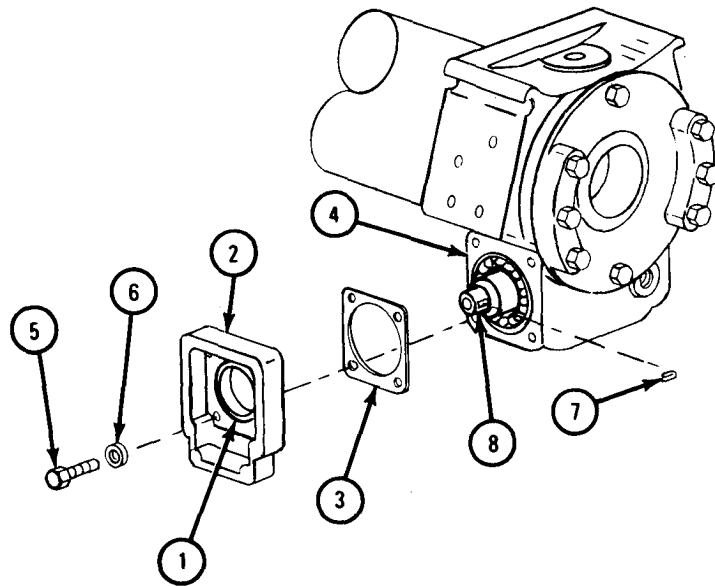

TA 089007

FRAME 8

1. Put in bearing cap oil seal (1).
2. Put on bearing cap gasket (2) and put bearing cap (3) in place.
3. Put in four screws and washers (4).

GO TO FRAME 9

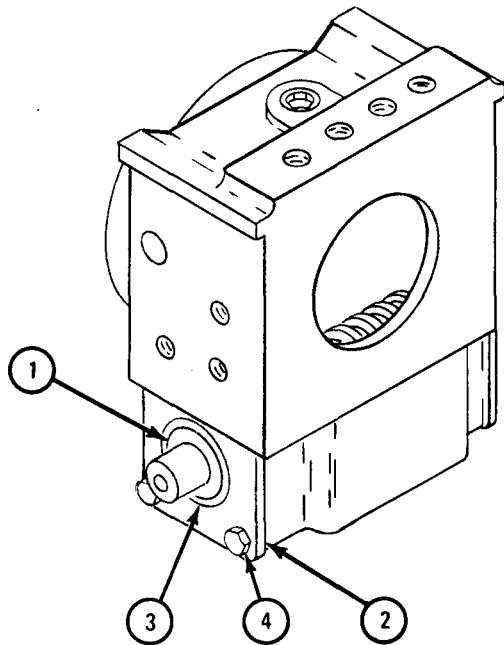

TA 089010

FRAME 9

- Soldier B 1. Hold gearcase assembly (1).
- Soldier A 2. Put drum assembly (2) on gearcase assembly (1).
3. Put on drum thrust ring (3).
4. Put in two sliding clutch keys (4)
5. Put on drum sliding clutch (5) and end frame bearing thrust ring (6).

GO TO FRAME 10

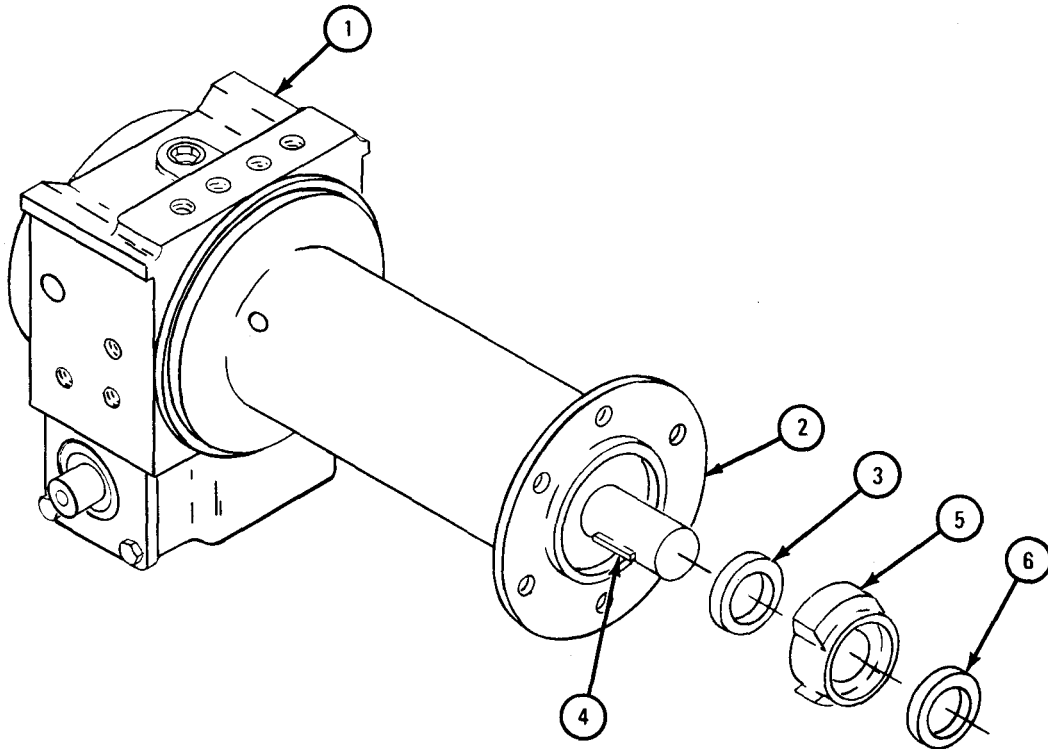

TA 089011

FRAME 10

1. Put in oil seal (1) and put on gasket (2). Mount brake case assembly (3) on end cover assembly (4).
2. Put in four screws (5) and washers (6).
3. Put woodruff key (7) in shaft (8).

GO TO FRAME 11

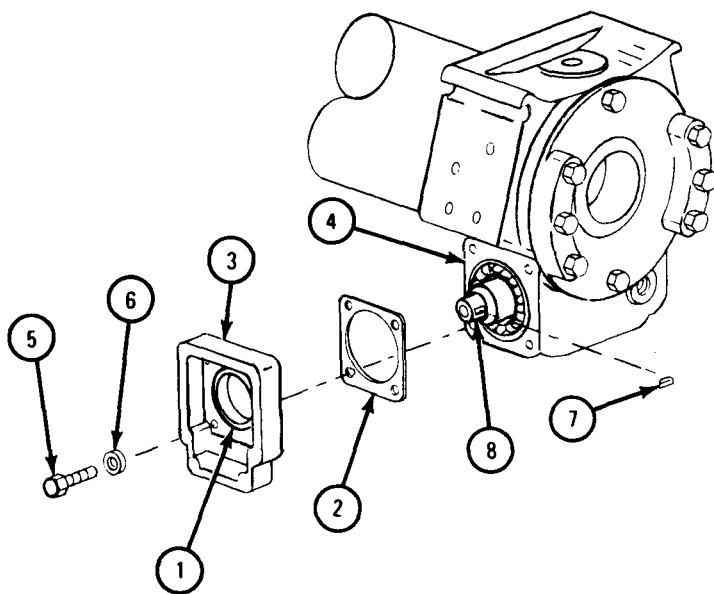

TA 089007

FRAME 11

1. Put in automatic brake disk (1) and automatic brake disk retainer (2).
2. Put in washer and screw (3).
3. Put in brake lining (4) and automatic brake band assembly (5).
4. Put in adjusting screw spring (6) and put on preformed packing (7), washer (8), and brake adjusting screw (9).

GO TO FRAME 12

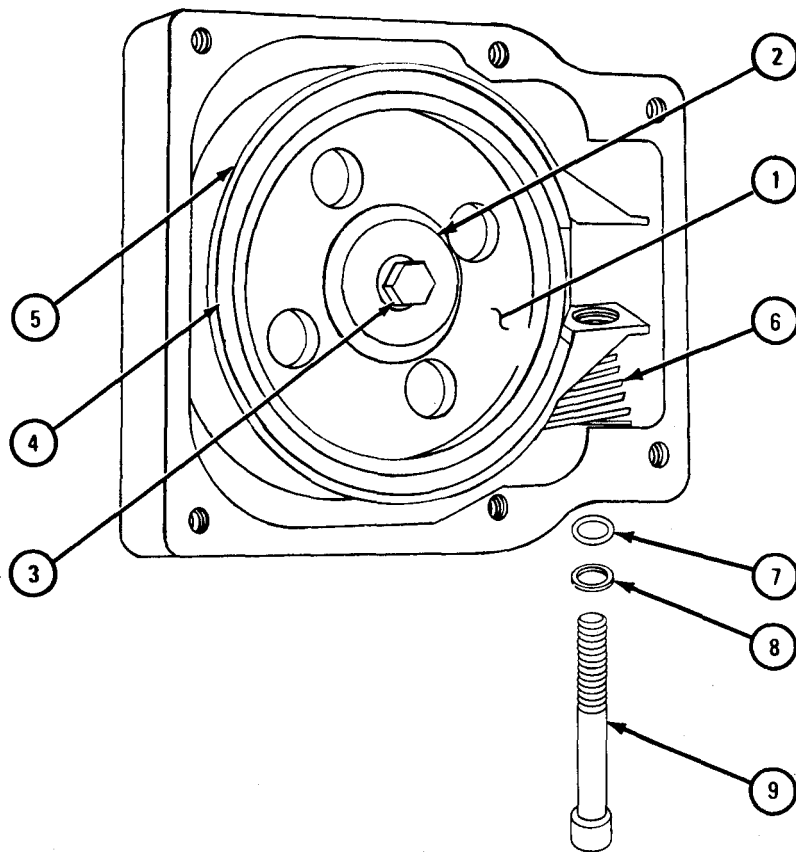

TA 089008

FRAME 12

1. Put on automatic brake case gasket (1).
2. Put automatic brake case cover (2) in place.
3. Put in six washers and screws (3).
4. Put rod (4) and two locknuts (5) in place on gearcase assembly (6).
5. Put on end frame assembly (7) and locknut (8).

GO TO FRAME 13

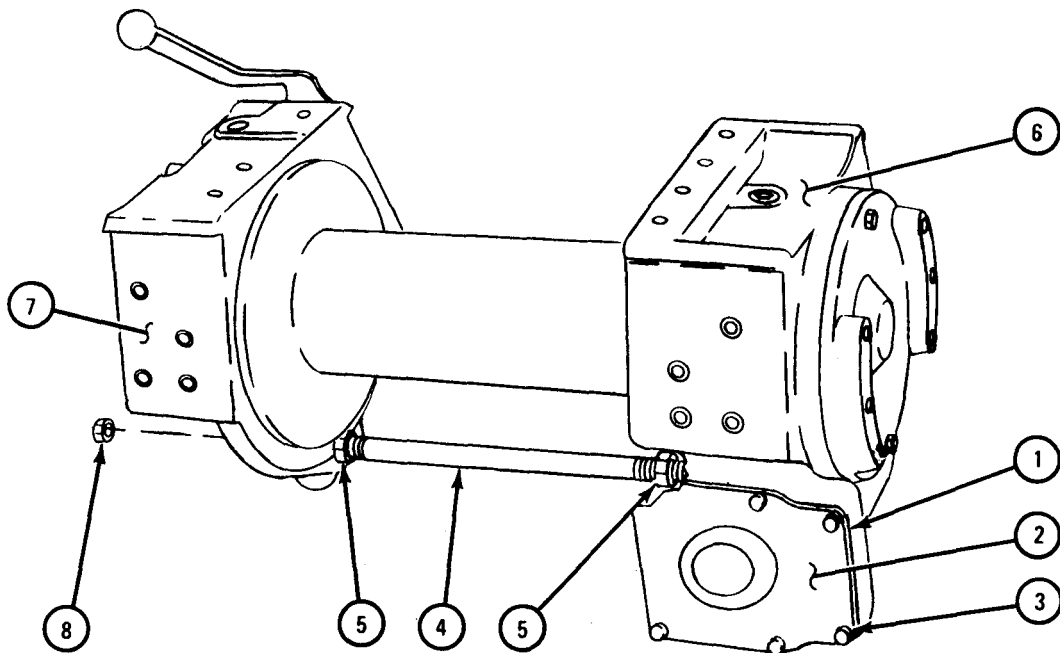

TA 089014

FRAME 13

1. Put rear tension channel (1) in place and put in six screws and washers (2).
2. Put top tension channel (3) in place and put in four screws and washers (4).

NOTE

Follow-on Maintenance Action Required:

1. Fill front winch. Refer to LO 9-2320-209-12/1.
2. Replace front winch. Refer to TM 9-2320-209-20.

END OF TASK

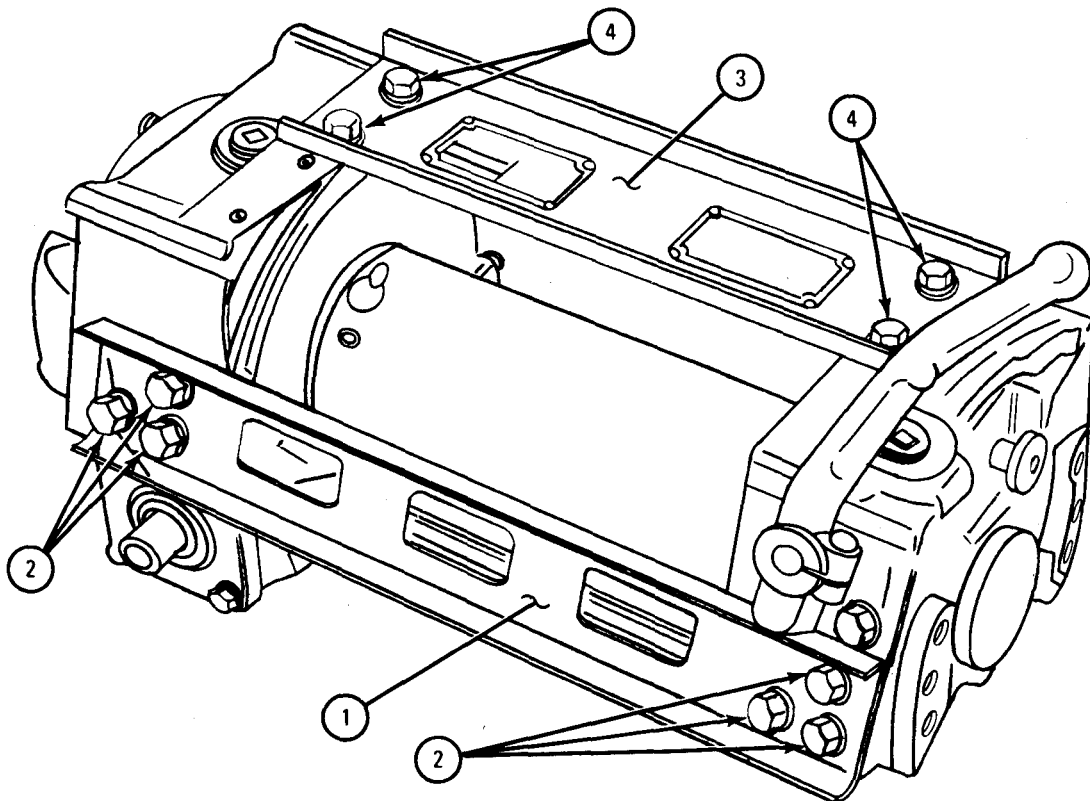

TA 089015

18-4. REAR WINCH REMOVAL, REPAIR, REPLACEMENT, AND TEST (TRUCK M756A2).

TOOLS: No special tools required

SUPPLIES: Artillery and automotive grease, type GAA, MIL-G-10924
Cotter pin
Solvent, dry cleaning, type II (SD-2), Fed. Spec P-D-680
End cap gasket (2)
Gearcase cover gasket
Automatic brake case gasket
Gear lubricating oil, GO 80/90, MIL-L-2105
Lubricating oil, ICE, OE/HDO 10, MIL-L-2104
Tubular rivet, MS 16536-91
Hydraulic preformed packing

PERSONNEL: TWO

EQUIPMENT CONDITION: Truck parked, engine off, handbrake set.

a. Preliminary Procedure. Remove cab protector. Refer to TM 9-2320-209-20.

b. Removal.

FRAME 1

1. Take out cotter pin (1) from each of two pins in master link (2).
2. Take off master link cap (3) from master link (2).
3. Take out master link (2).
4. Take out pin (4).
5. Take off drive chain (5).

GO TO FRAME 2

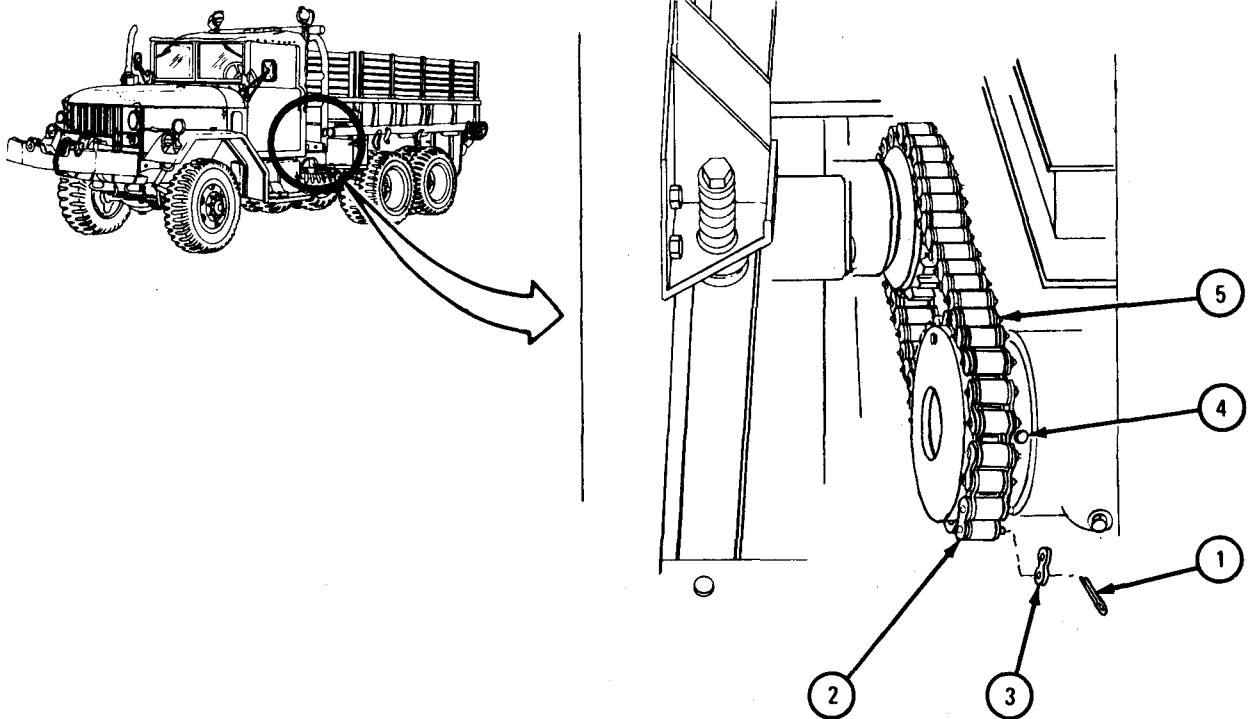

TA 101052

FRAME 2

1. Using hoist, support weight of rear winch (1).
2. Take out four capscrews (2) and washers (3) from left bracket (4).
3. Take out four capscrews (5) and washers (6) from right bracket (7).
4. Using hoist, take out rear winch (1).

END OF TASK

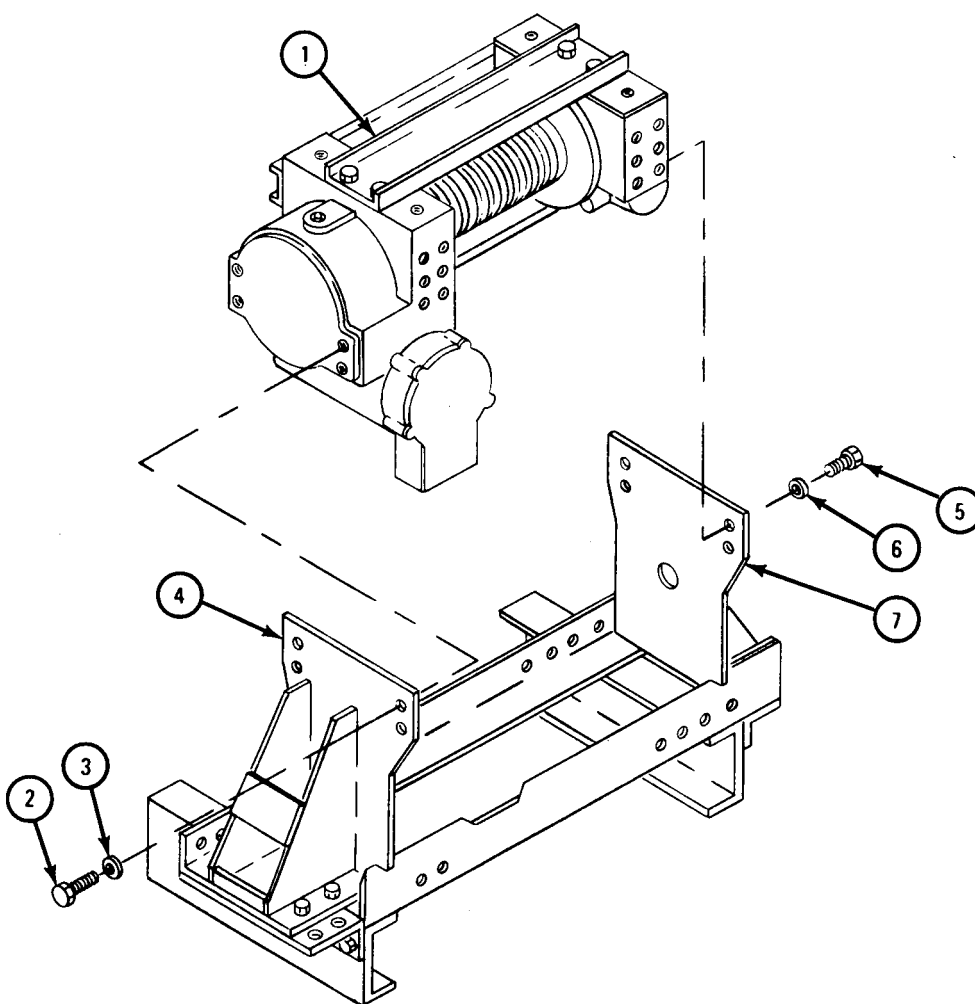

TA 101054

c. Disassembly.

FRAME 1

1. Take out and throw away cotter pin (1) from shear pin (2).
2. Take out shear pin (2).
3. Take out expansion plug (3). Using punch, drive straight pin (4) through hub (5) and shaft (6).
4. Pull hub (5) from shaft (6).
5. Take off two retaining rings (7) and sprocket (8).
6. Press bushing (9) out of sprocket (8).
7. Take off lubrication fitting (10).

GO TO FRAME 2

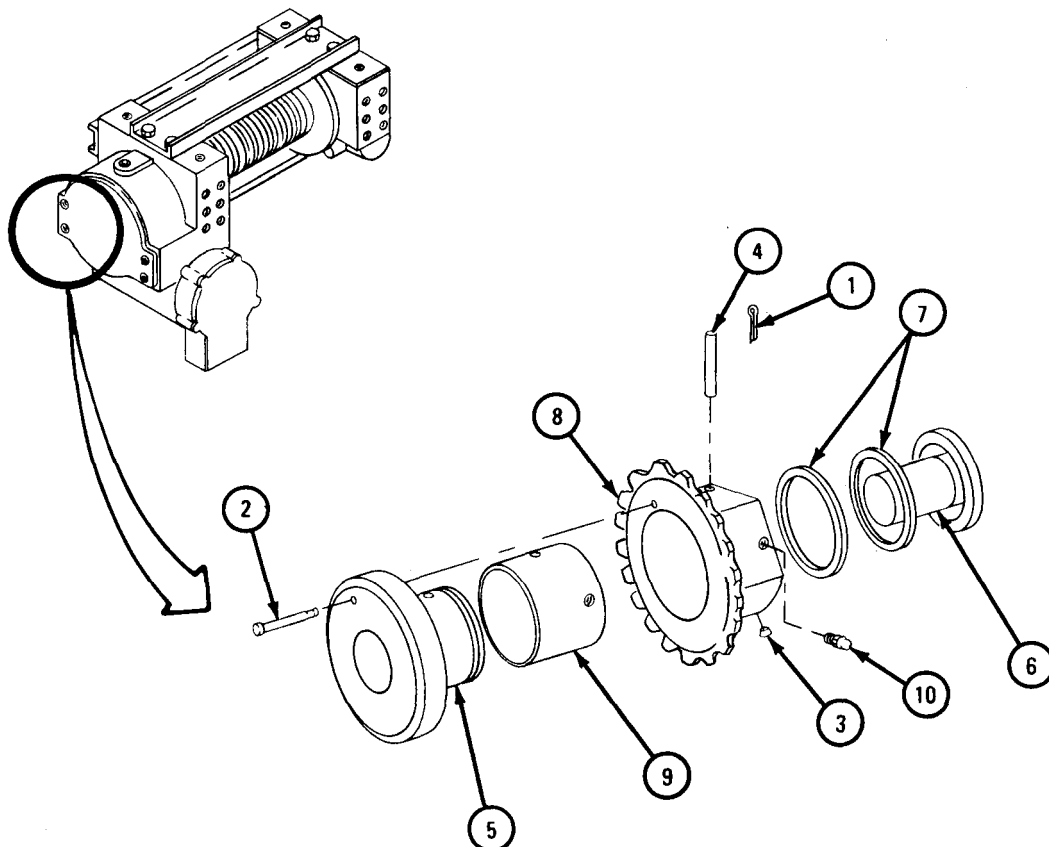

TA 101055

FRAME 2

1. Put a five-gallon container under two drain plugs (1).
2. Take out two drain plugs (1) from gearcase (2) and end frame (3). Drain oil.
3. Take out four capscrews and washers (4).
4. Lift channel (5) off gearcase (2) and end frame (3).
5. Take out four capscrews and washers (6). Take off channel (7).
6. Take off nut (8) from tie rod (9).
7. Using hoist, support cable and drum assembly (10). Lift off end frame (3). Leave hoist on drum.
8. Take off tie rod (9).

GO TO FRAME 3

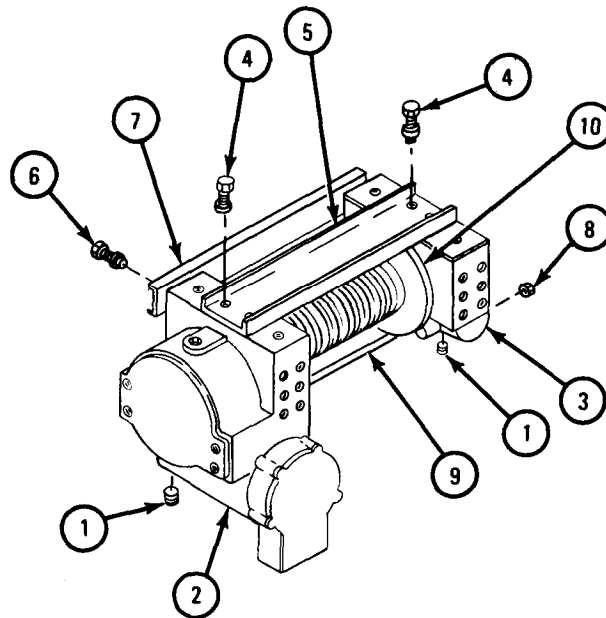

TA 101056

FRAME 3

1. Take out bearing with sleeve assembly (1). Take drag brake assembly (2) out of end frame (3).
2. Take out drag brake adjusting screw (4) from rear of end frame (3).

NOTE

Do not take out oil seal (5) unless it is damaged. Refer to para 18-4e for inspection procedures.

3. Take out oil seal (5).
4. Take out plugs (6 and 7).
5. Take out drum lock assembly (8) from rear of end frame (3).

GO TO FRAME 4

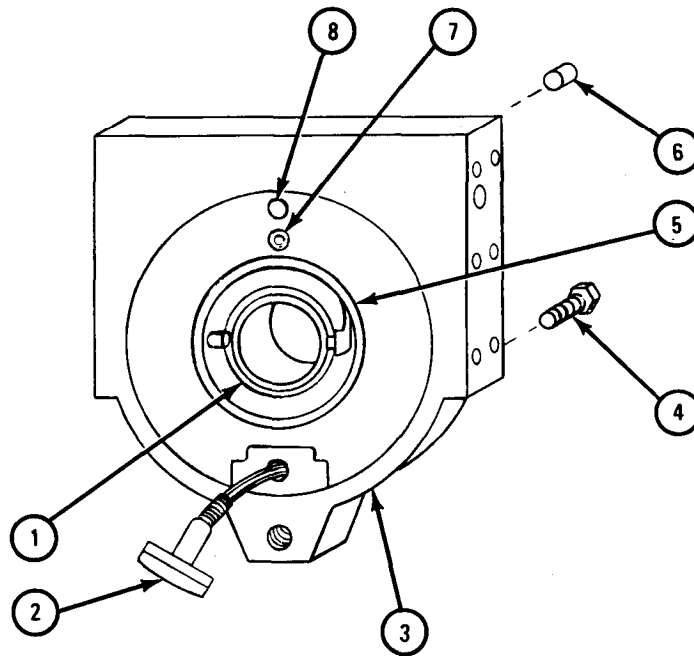

TA 101057

FRAME 4

1. Take off two nuts (1). Take off latch (2), bolt (3), spring (4), and spacer (5) from poppet (6).

GO TO FRAME 5

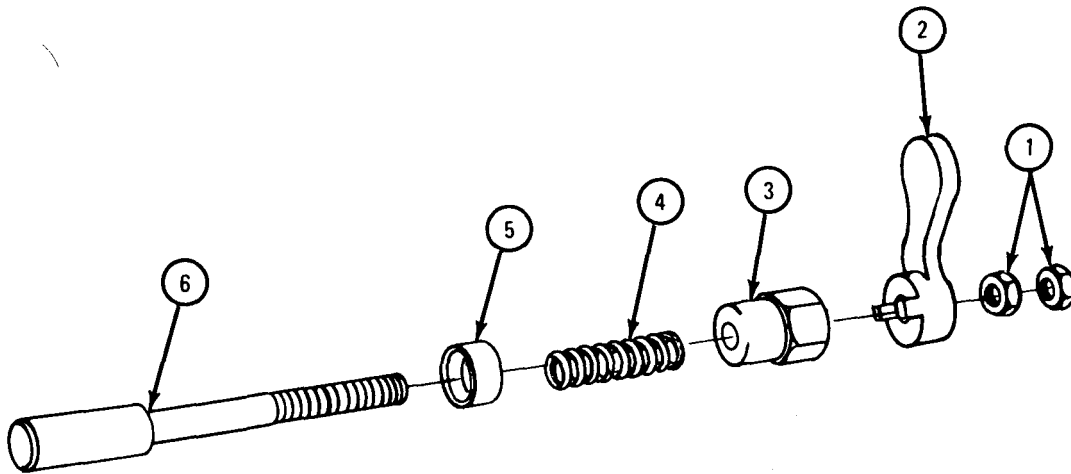

TA 101058

FRAME 5

1. Take out setscrew (1) from shifter yoke (2).
2. Pull out shifter shaft (3).
3. Take out shifter yoke (2).

Do not take out shifter shaft oil seal (4) unless it is damaged.
Refer to para 18-4e for inspection procedures.

4. Take out shifter shaft oil seal (4).

GO TO FRAME 6

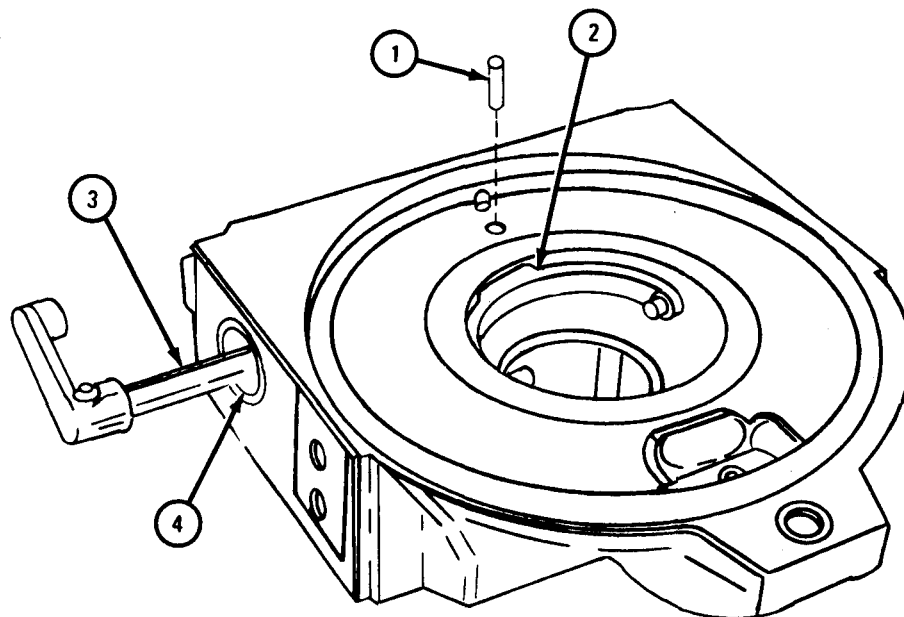

TA 101059

FRAME 6

1. Take off end thrust ring (1) from shaft (2).
2. Slide sliding clutch (3) off shaft (2).
3. Take out two keys (4).
4. Slide off thrust ring (5).
5. Using hoist to hold weight of drum and cable assembly (6), pull off shaft (2) and gearcase assembly (7).
6. Lower drum and cable assembly (6) and press out sleeve bearings (8 and 9).

GO TO FRAME 7

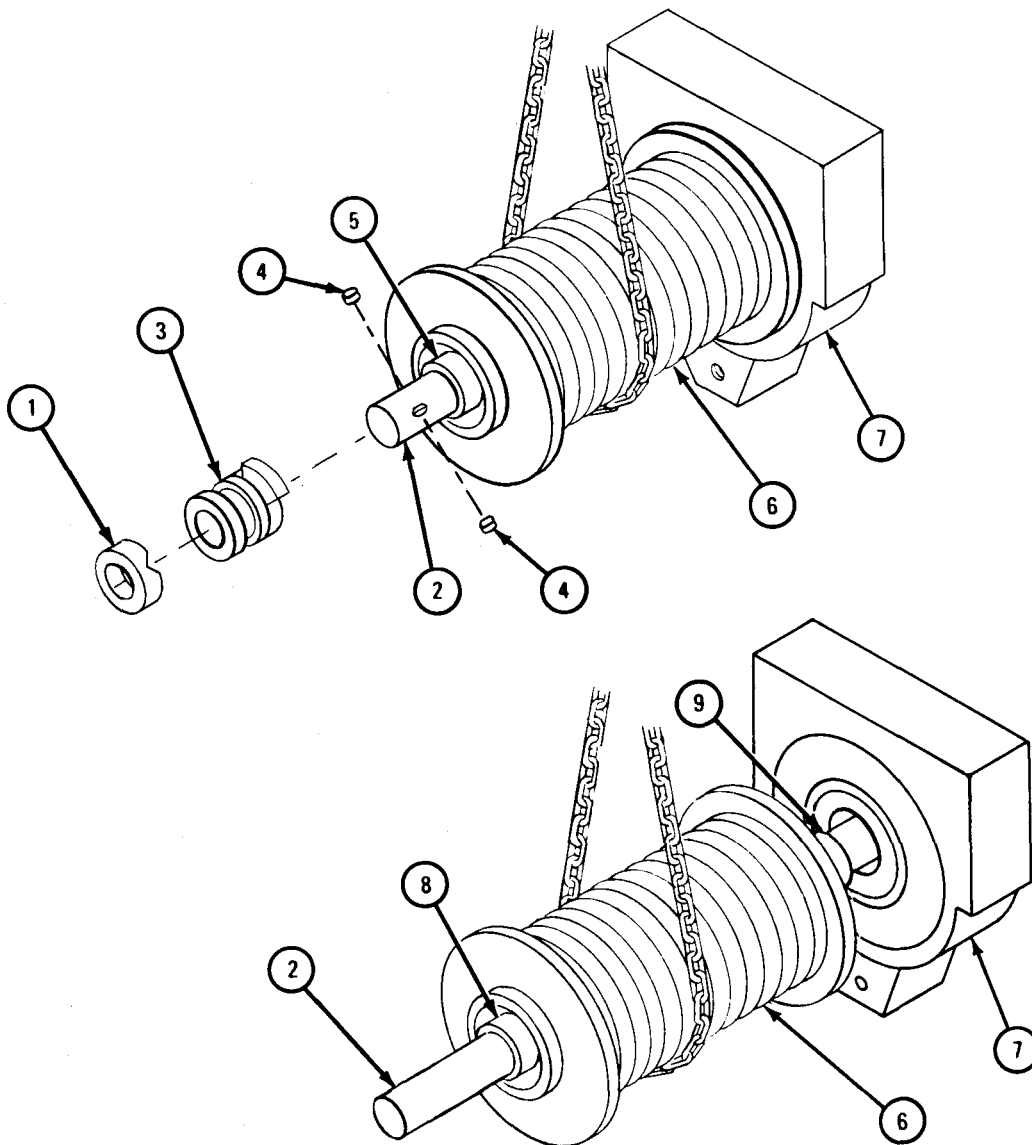

TA 101060

FRAME 7

1. Take out four capscrews (1) from cover (2).

NOTE

Do not take out sleeve bearing (3) unless it is damaged.
Refer to para 18-4e for inspection procedures.

2. Take off cover (2) and gasket (4). Throw away gasket. Pull sleeve bearing (3) out of cover.
3. Take out four capscrews (5) and washers (6).

NOTE

Do not take out oil seal (7) unless it is damaged. Refer
to para 18-4e for inspection procedures.

4. Take off bearing cap (8) with oil seal (7). Press out oil seal.
5. Take off and throw away gasket (9).

GO TO FRAME 8

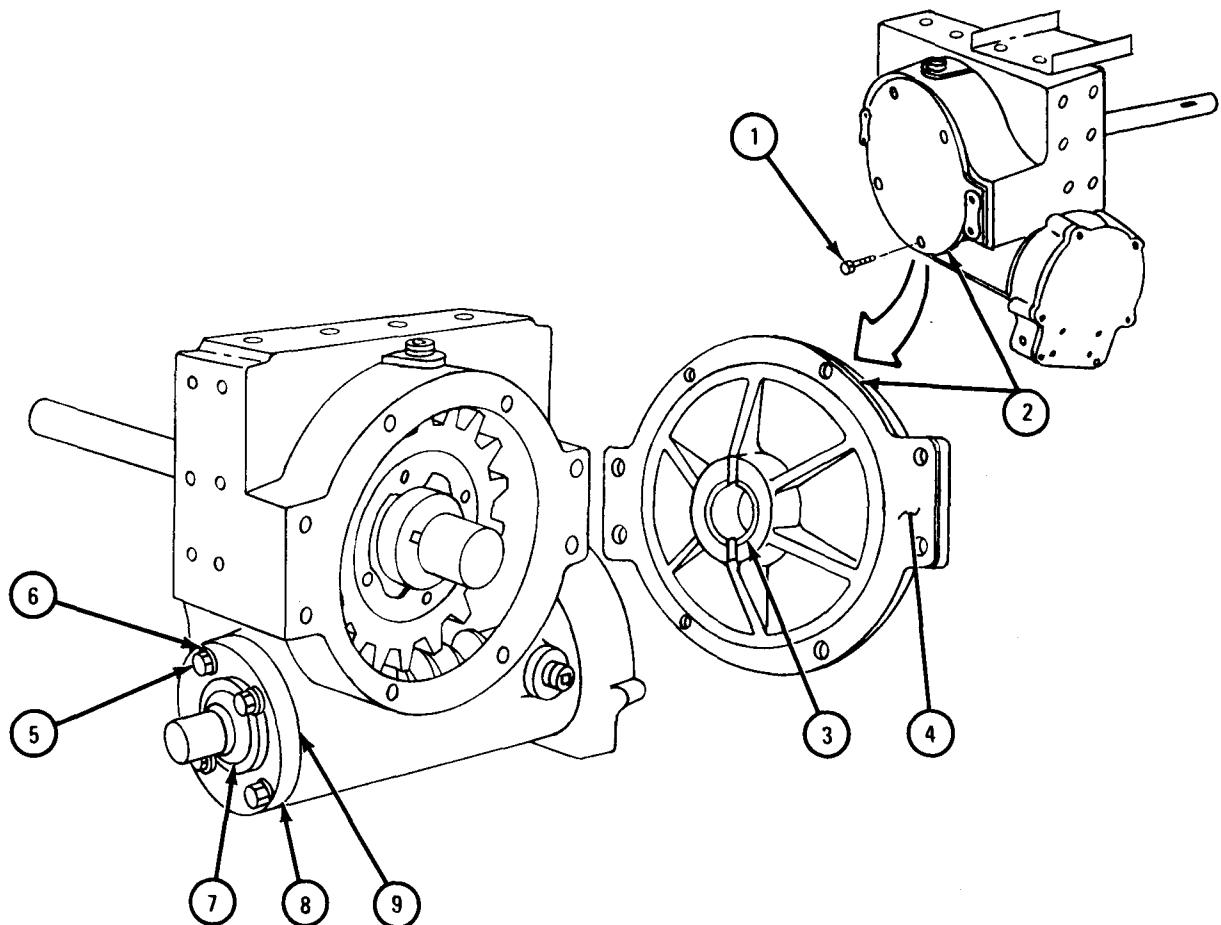

TA 101061

FRAME 8

1. Take out six capscrews and washers (1).
2. Lift off cover (2) and gasket (3).
3. Take out brake adjusting screw (4), washer (5), and preformed packing (6).
4. Take out expansion plug (7) from housing (8).
5. Take out spring (9).
6. Take out brake band with lining assembly (10).

GO TO FRAME 9

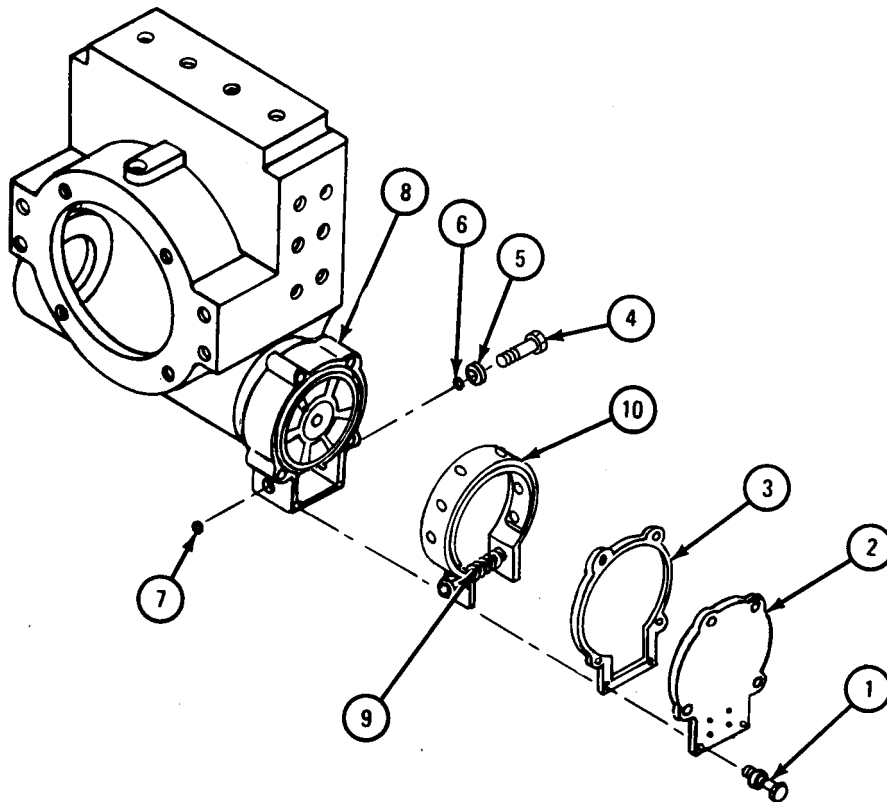

TA 101062

FRAME 9

1. Take out capscrew (1), washer (2), and retaining washer (3).
2. Pull drive worm brake disk (4) out of housing (5).
3. Take out key (6) from shaft (7).
4. Take out four capscrews and washers (8).
5. Take off housing (5) and gasket (9).

NOTE

Do not take out oil seal (10) unless it is damaged. Refer to para 18-4e for inspection procedures.

6. Press out oil seal (10).

GO TO FRAME 10

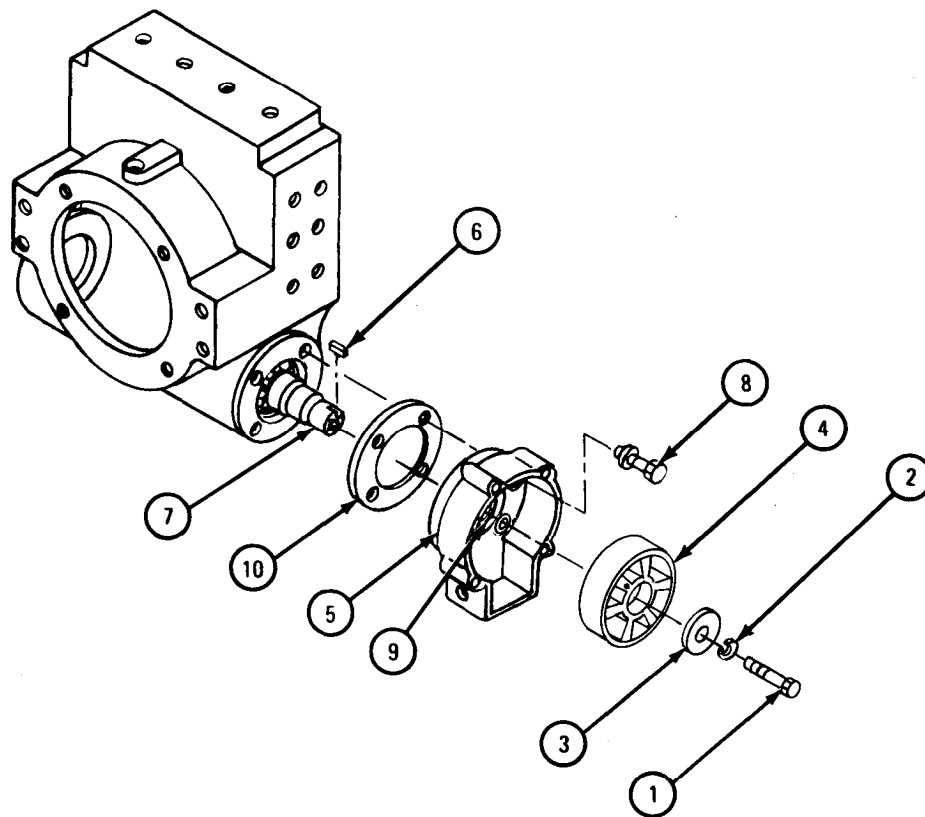

TA 101063

FRAME 10

1. Using soft-faced hammer, tap drive worm (1) until worm and rear bearing (2) drop into gearcase (3) and front bearing is driven out of gearcase.
2. Take out drumshaft (4) with gear (5).
3. Using hammer and brass drift, drive off rear bearing (2). Take drive worm (1) and rear bearing out of gearcase (3).
4. Press gear (5) off drumshaft (4). Take out two keys
5. Press out bearing (7).

NOTE

Do not take out oil seal (8), unless it is damaged. Refer to para 18-4e for inspection procedures.

6. Take out oil seal (8).

END OF TASK

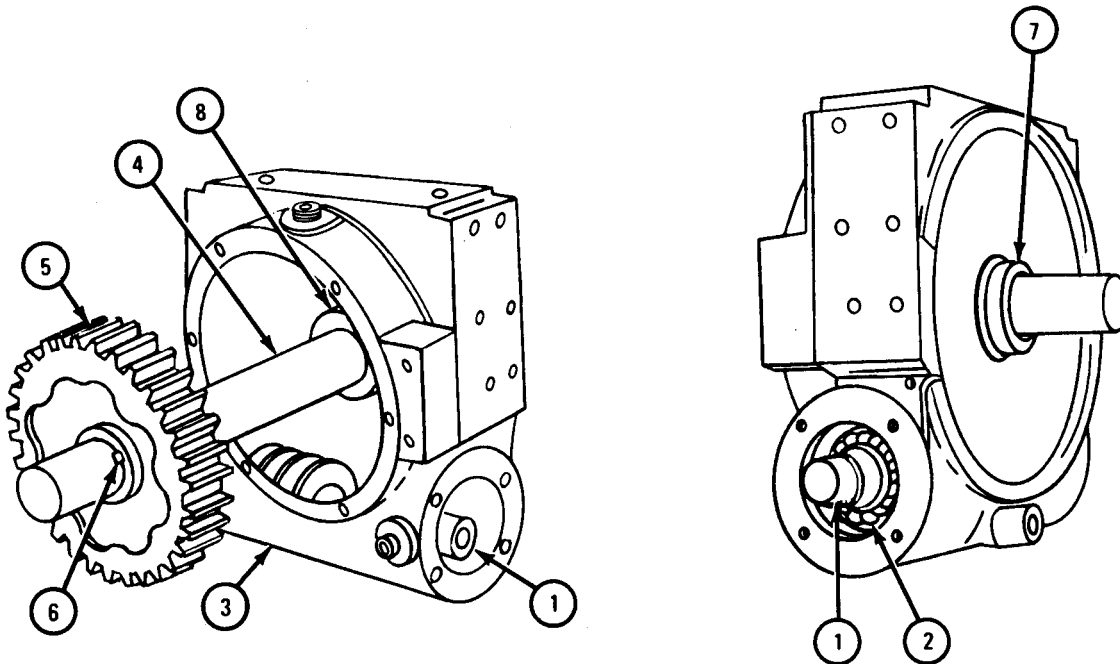

TA 101064

d. Cleaning. There are no special cleaning procedures needed. Refer to cleaning procedures given in Part 1, para 1-3.

CAUTION

Do not use solvent on brake band and lining. Band and lining will be damaged.

e. Inspection and Repair.

FRAME 1

1. Check that bearing balls (1) have no scores, rough spots or other damage. If bearing balls are damaged, get new ones in their place.
2. Put a coat of oil on each bearing (2) and turn slowly by hand. Bearing must turn smoothly and freely without binding. If bearings are worn or damaged, get new ones in their place.

GO TO FRAME 2

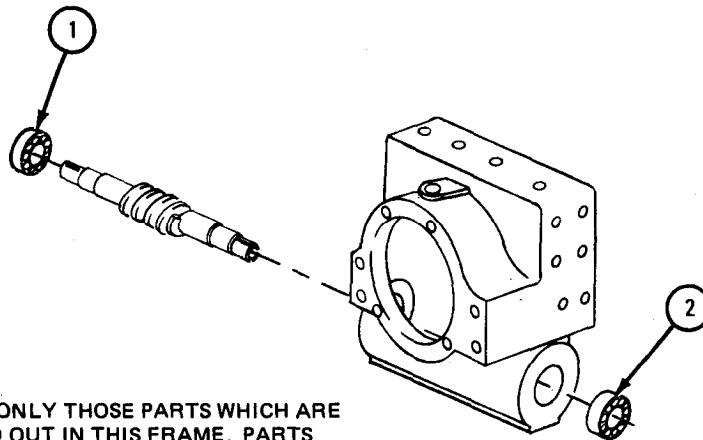

NOTE: CHECK ONLY THOSE PARTS WHICH ARE CALLED OUT IN THIS FRAME. PARTS WITHOUT CALLOUTS ARE SHOWN ONLY FOR REFERENCE PURPOSES OR ARE CHECKED IN ANOTHER FRAME.

TA 101065

FRAME 2

1. Check that bores of sleeve bearings (1 and 2) have no burrs, nicks, scoring or roughness. Take off raised metal, nicks, scoring, and roughness with a honing stone, and polish with crocus cloth.
2. Using magnifying glass, check that drum shaft (3) has no cracks. If drum shaft is cracked, get a new one.
3. Check that drum shaft (3) is not scored or worn. If drum shaft is scored or worn, get a new one.
4. Check that teeth of gears (4 and 5) are not broken, chipped or scored. If gear teeth are damaged, get a new gear.
5. Check that sliding clutch (6), shifter yoke (7), and two thrust rings (8) are not worn. If parts are worn, get new ones.
6. Check that flange on drum (9) is not chipped or worn where drag brake touches it. If flange is damaged, get a new drum. Check that all oil passages are open.

WARNING

Always wear leather gloves when handling winch cable.
 Never let cable run through hands. Broken or rusty wires can cause serious injury to personnel.

7. Unwind cable (10). Check that cable has no broken or frayed strands. If cable is damaged, take it off drum and put on a new one. Refer to TM 9-2320-209-20.

GO TO FRAME 3

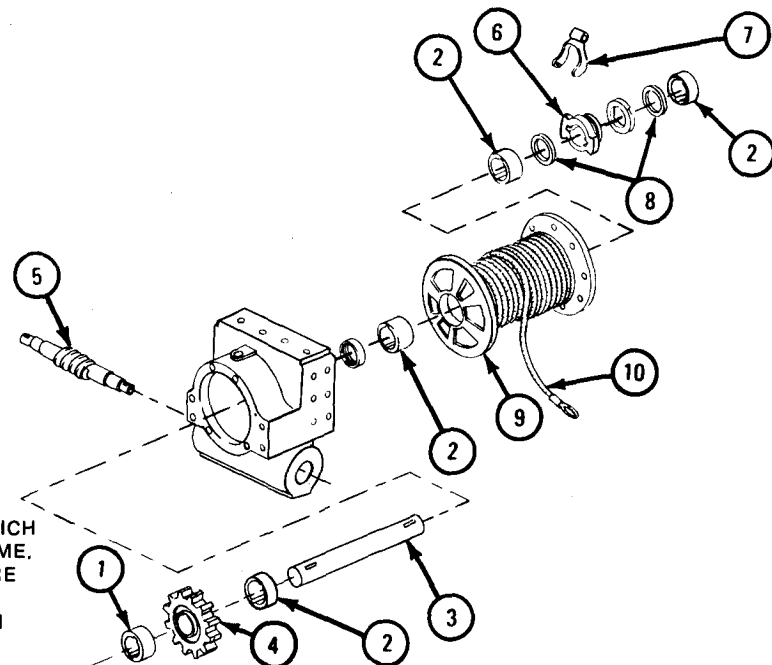

NOTE: CHECK ONLY THOSE PARTS WHICH ARE CALLED OUT IN THIS FRAME. PARTS WITHOUT CALLOUTS ARE SHOWN ONLY FOR REFERENCE PURPOSES OR ARE CHECKED IN ANOTHER FRAME.

TA 101066

FRAME 3

NOTE

Readings must be within limits given in table 18-6. If readings are not within given limits, throw away part and get a new one.

1. Measure inside diameter of end frame sleeve bearing (1).
2. Measure outside diameter of drum shaft (2).
3. Measure fit of sleeve bearing (1) on drum shaft (2).
4. Measure inside diameters of sleeve bearings (3 and 4) and bearings (5 and 6).
5. Measure fit of sleeve bearings (3 and 4) on drum shaft (2).
6. Measure fit of gearcase bearings (5 and 6) on drum shaft (2).

GO TO FRAME 4

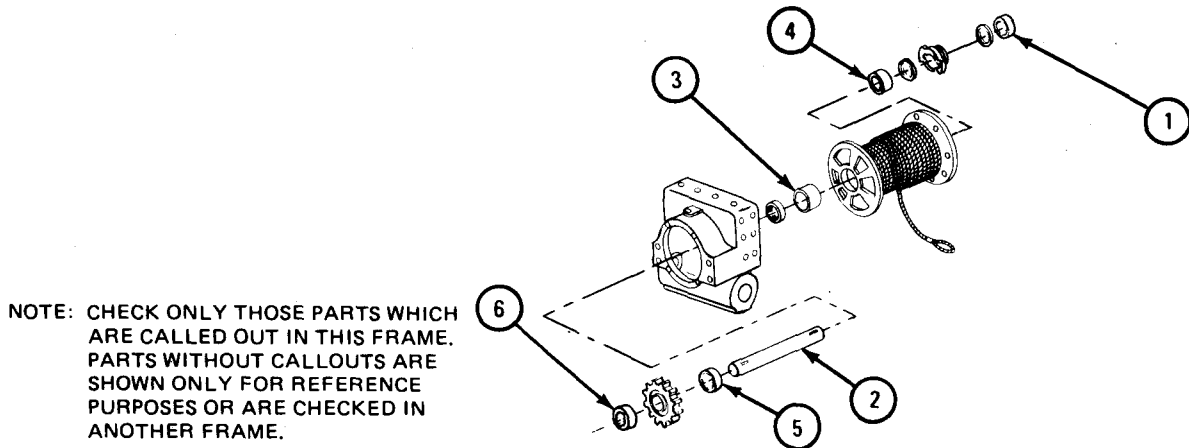

TA 101067

Table 18-6. Rear Winch (Drum Shaft and Bearings) Wear Limits

Index Number	Item/Point of Measurement	Size and Fit of New Parts (inches)	Wear Limit (inches)
1	End frame bearing inside diameter	2.127 to 2.130	0.015
2	Drum shaft outside diameter	2.123 to 2.125	0.002
1 and 2	Fit of bearing on drum shaft	0.002 to 0.007	None
3 and 4	Drum bearings inside diameter	2.127 to 2.130	0.015
2, 3, and 4	Fit of drum bearings on drum shaft	0.002 to 0.007	None
5 and 6	Gearcase bearing inside diameter	2.127 to 2.130	0.008
2, 5, and 6	Fit of gearcase bearing on drum shaft	0.002 to 0.007	None

FRAME 4

1. Check that machined surface on cover (1) and gearcase (2) where gasket (3) is placed has no nicks, burrs or old gasket material.
2. Check that machined surface on bearing cap (4) and gearcase (2) where gasket (5) is placed has no nicks, burrs or old gasket material.
3. Check that machined surface on brake housing (6) and gearcase (2) where gasket (7) is placed has no nicks, burrs or old gasket material.
4. Check that machined surface on cover (8) and brake housing (6) where gasket (9) is placed has no nicks, burrs or old gasket material.
5. Take off any old gasket material, and rub off any nicks or burrs with a honing stone.

GO TO FRAME 5

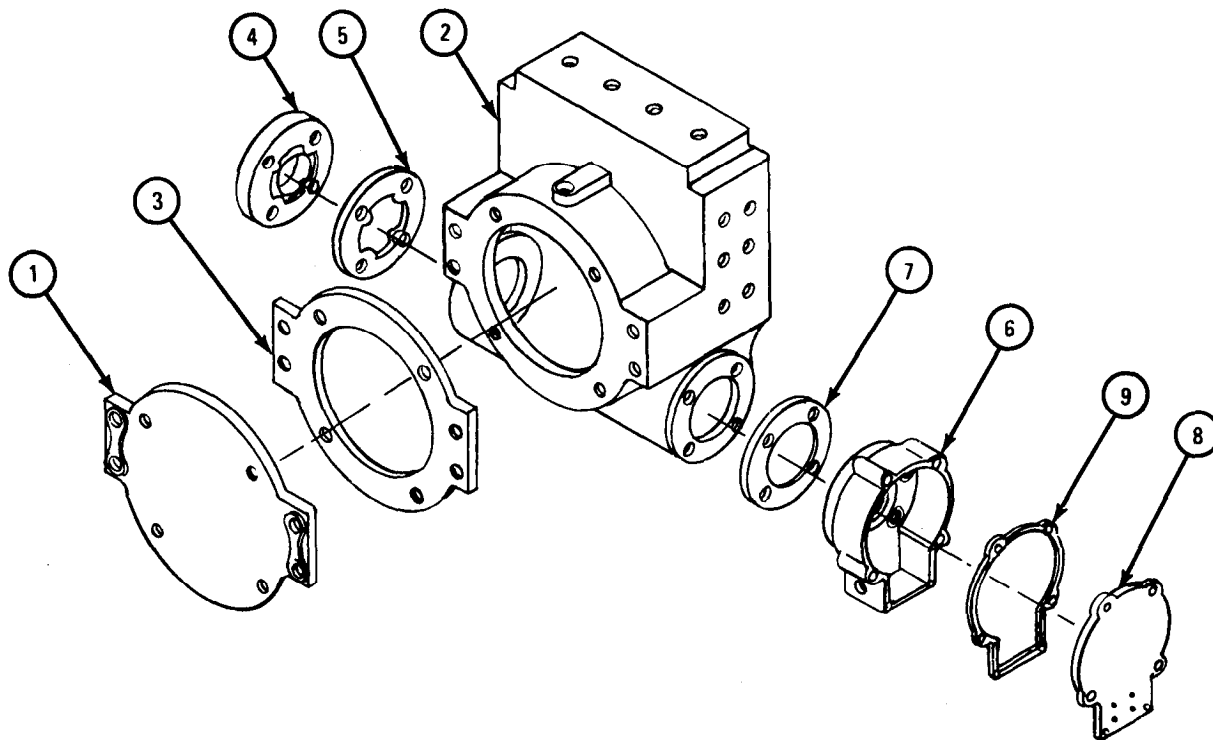

TA 101068

FRAME 5

1. Check that rubber on oil seals (1 through 5) is not dry, cracked, broken or burned. If oil seal is damaged, get a new one.
2. Check that sharp edge of oil seals (1 through 5) is not torn or broken. If sharp edge of oil seal is damaged, get a new oil seal.
3. Check that there are no oil leaks around oil seals (1 through 5). If there are oil leaks, get a new oil seal.

GO TO FRAME 6

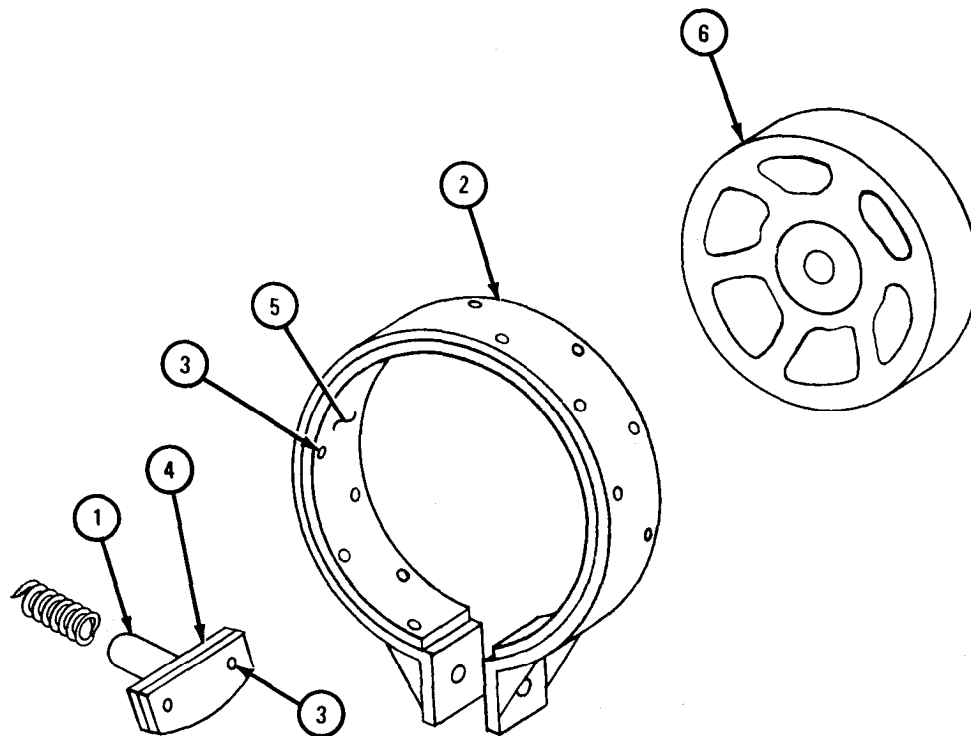

NOTE: CHECK ONLY THOSE PARTS WHICH ARE CALLED OUT IN THIS FRAME. PARTS WITHOUT CALLOUTS ARE SHOWN ONLY FOR REFERENCE PURPOSES OR ARE CHECKED IN ANOTHER FRAME.

TA 101070

FRAME 6

1. Check that lining on drag brake (1) or drive worm brake (2) is not scored, burned, oil soaked or worn down to rivets (3). Take off damaged brake lining and rivets and get new ones in their place.
2. Put new lining (4) on drag brake (1). Put in two brass tubular rivets (3).
3. Put new lining (5) on drive brake (2). Put one rivet (3) at each end of band. Put in every other rivet until all rivets are put on.
4. Check that surface of drive worm brake disk (6) is not scored or rough. If brake disk is damaged, get a new one.

GO TO FRAME 7

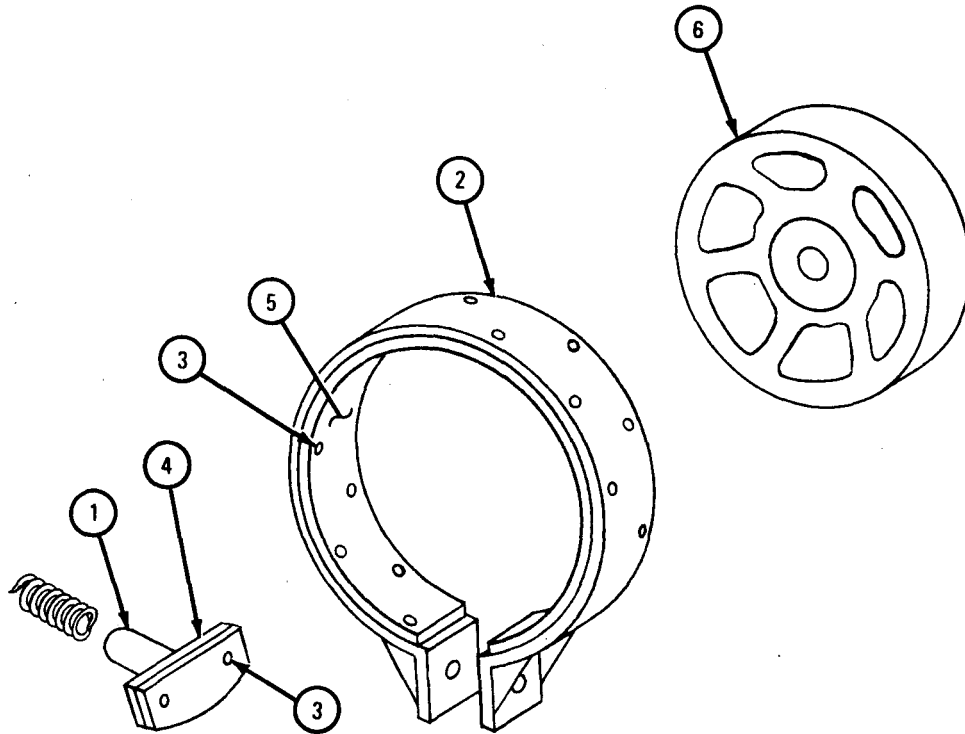

NOTE: CHECK ONLY THOSE PARTS WHICH ARE CALLED OUT IN THIS FRAME. PARTS WITHOUT CALLOUTS ARE SHOWN ONLY FOR REFERENCE PURPOSES OR ARE CHECKED IN ANOTHER FRAME.

TA 101070

FRAME 7

1. Check that channels (1 and 2) have no cracks. If channel is damaged, get a new one.
2. Using magnifying glass, check that gearcase (3) and end frame (4) have no cracks. If gearcase or end frame is damaged, get a new one.
3. Check that threads in tapped holes of gearcase (3) and end frame (2) are not stripped or crossthreaded. If threads are damaged, retap holes.

END OF TASK

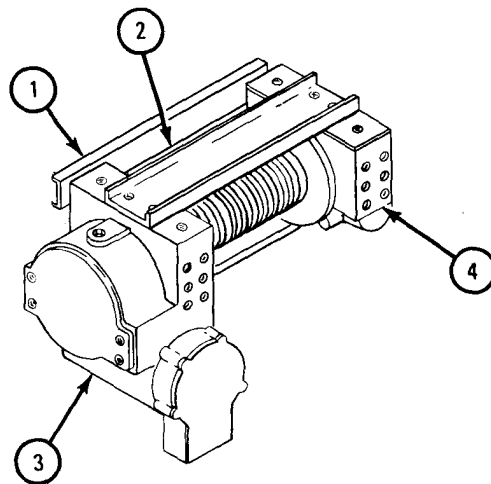

TA 101071

f. Assembly.

FRAME 1

1. Hold drum shaft gear (1) and shaft (2), alining two keys (3) in shaft with keyway in hub of drum shaft gear.
2. Press shaft (2) through drum shaft gear (1) until keys (3) are seated in drum shaft gear hub.
3. If oil seal (4) was taken out, press new oil seal into gearcase (5).
4. Press bearing (6) into gearcase (5).
5. Put drum shaft gear (1) with shaft (2) into gearcase (5).
6. Place bearing (7) in gearcase (5). Slide drive worm (8) into gearcase from the other side. Mesh drive worm with drum shaft gear (1).
7. Aline drive worm (8) with bearing (7) and hold in place. Using a soft-faced hammer, tap drive worm. Seat bearing in gearcase (5).

GO TO FRAME 2

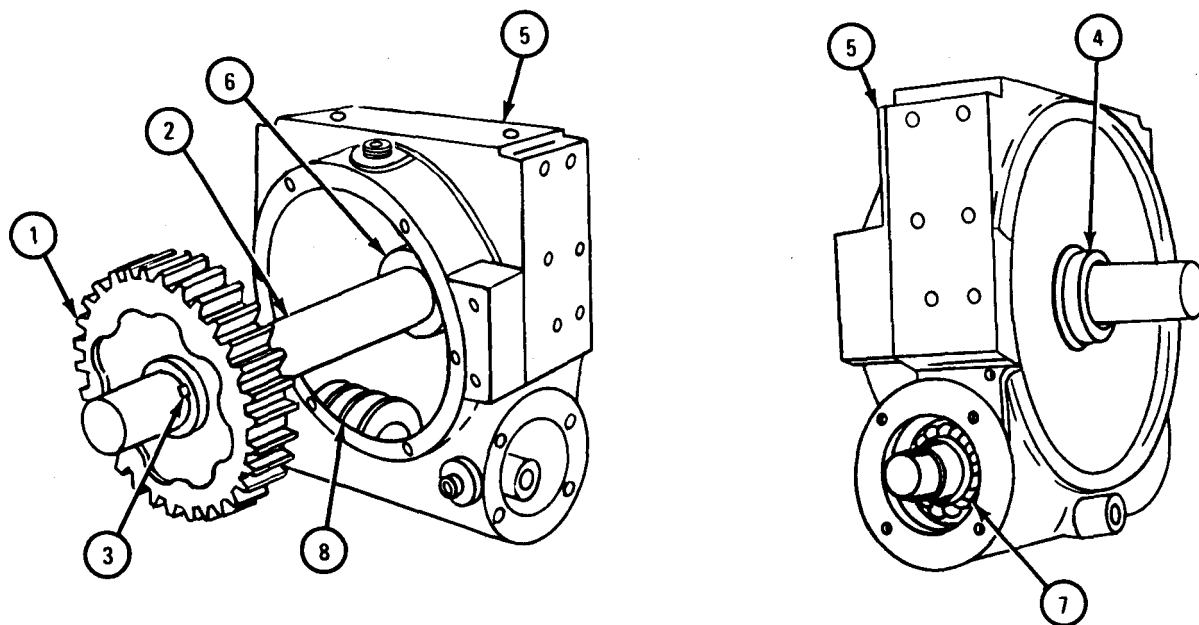

TA 101072

FRAME 2

1. If oil seal (1) was taken out, press new seal into housing (2).
2. Place gasket (3) and housing (2) on gearcase (4). Aline mounting holes.
3. Put in four capscrews and washers (5).
4. Press bearing (6) into gearcase (4).
5. If oil seal (7) was taken out, press new seal into bearing cap (8).
6. Place gasket (9) and bearing cap (8) on gearcase (4). Aline mounting holes.
7. Put in four capscrews and washers (10).

GO TO FRAME 3

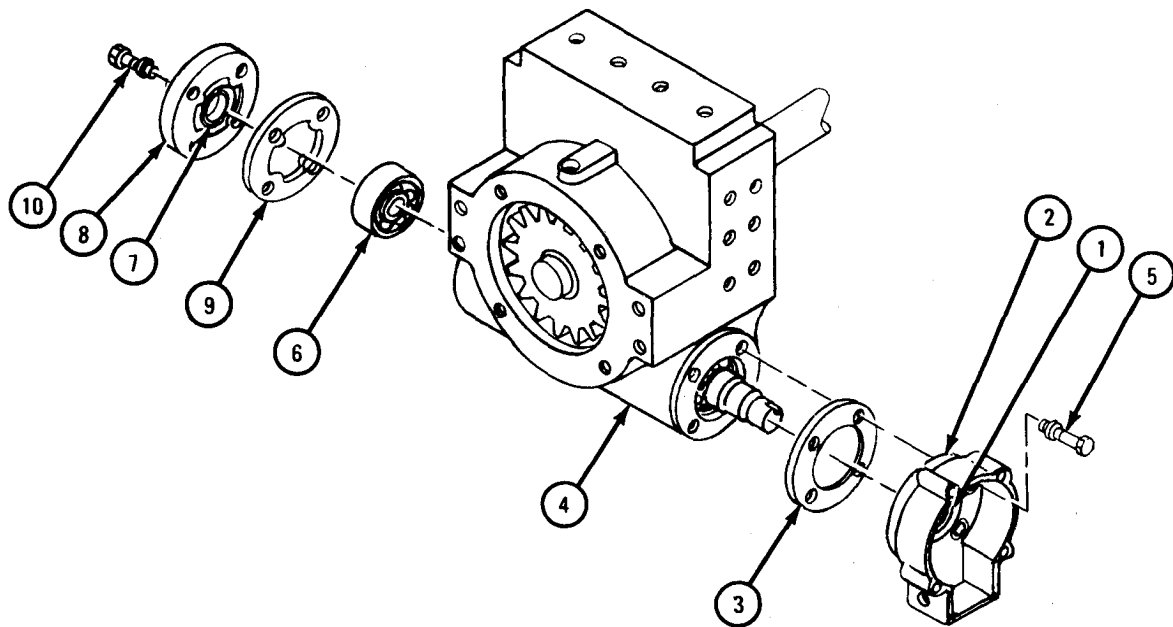

TA 101073

FRAME 3

1. Place key (1) in drive worm (2). Press brake disk (3) onto drive worm.
2. Put on retaining washer (4), washer (5), and capscrew (6).
3. Place brake band (7) over brake disk (3).
4. Place adjusting spring (8) between ends of brake band (7).

GO TO FRAME 4

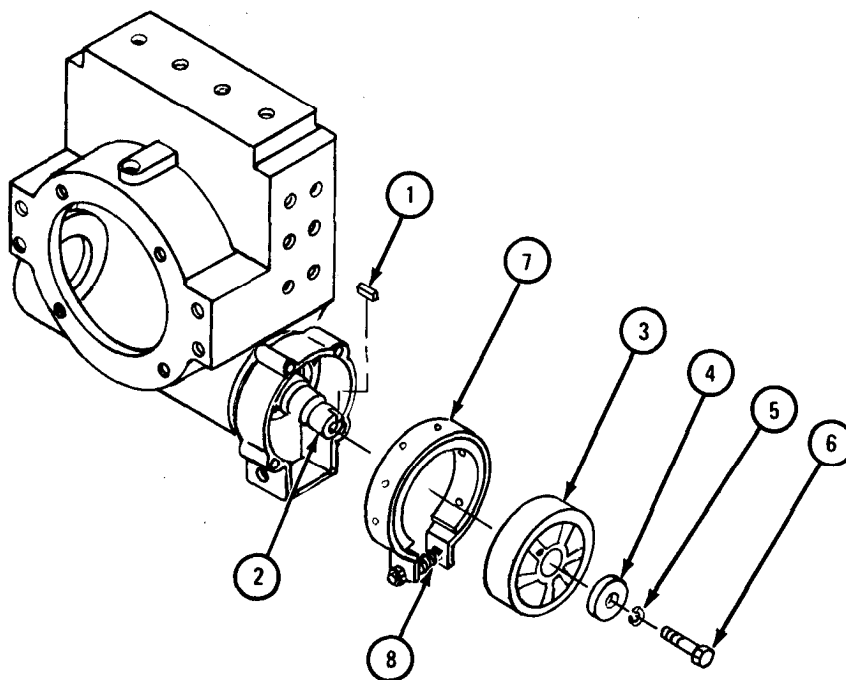

TA 101074

FRAME 4

1. Put washer (1) on capscrew (2).
2. Put preformed packing (3) on capscrew (2).
3. Put capscrew (2) with washer (1) and preformed packing (3) through housing (4), spring (5), and lugs on brake band (6).
4. Screw in capscrew (2) enough to hold brake band (6). Do not tighten capscrew.
5. Place gasket (7) and cover (8) on housing (4). Aline mounting holes.
6. Put in six capscrews with washers (9).
7. Put in expansion plug (10).

GO TO FRAME 5

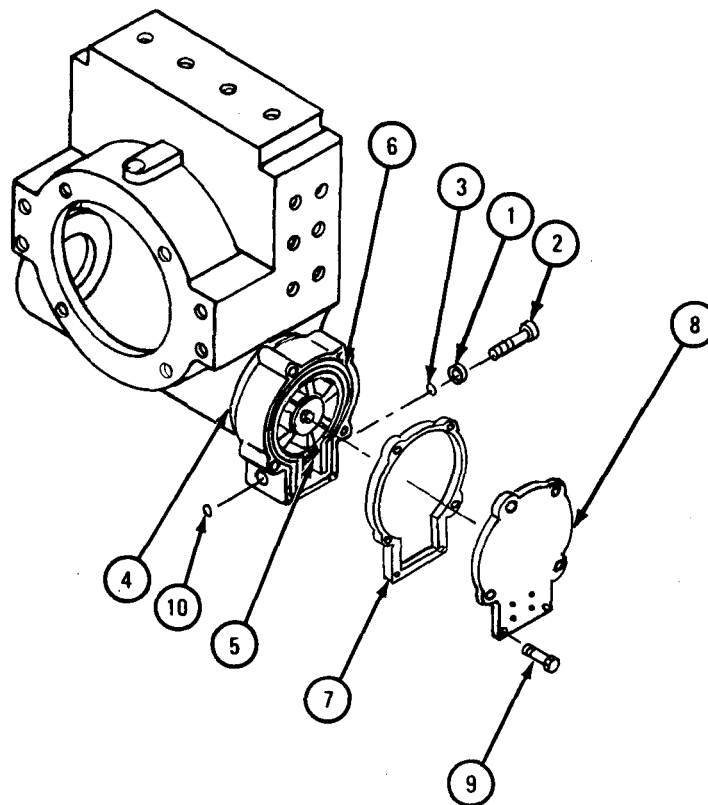

TA 101075

FRAME 5

1. If sleeve bearing (1) was taken out, press new bearing into gearcase cover (2).
2. Place gasket (3) and gearcase cover (2) on gearcase (4). Aline mounting holes.
3. Put on four capscrews (5).
4. Put nuts (6 and 7) on tie rod (8).
5. Thread tie rod (8) on gearcase (4). Tighten nut (6) and lock tie rod to gearcase.

GO TO FRAME 6

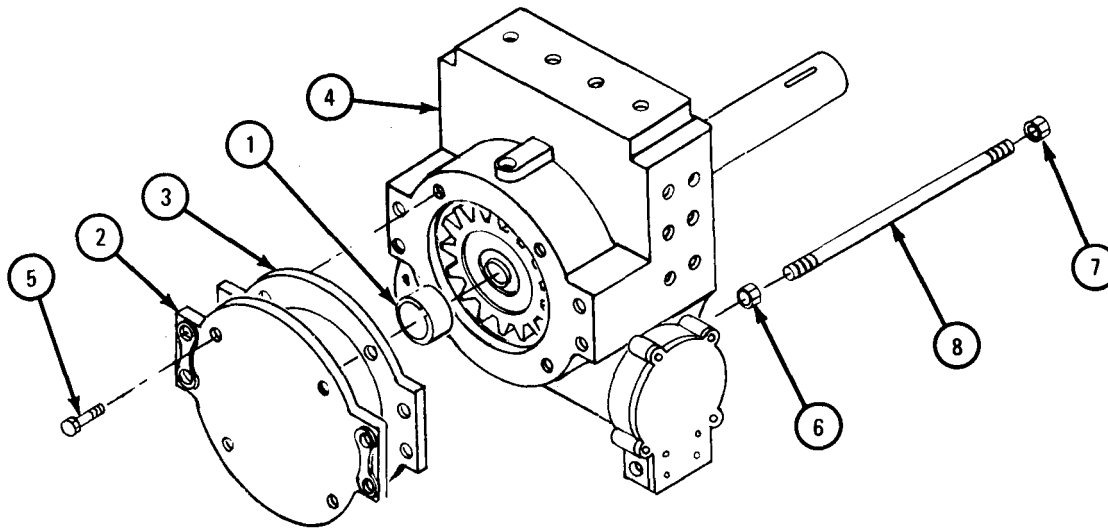

TA 101076

FRAME 6

1. Using hoist, hold drum (1) and press bearings (2 and 3) on drum. Leave hoist on drum.
2. Put on thrust ring (4).
3. Put drum (1) on drum shaft (5), against gearcase (6).
4. Put two clutch keys (7) on drum shaft (5).
5. Put drum sliding clutch (8) in place on drum shaft (5) and put on thrust ring (9).

GO TO FRAME 7

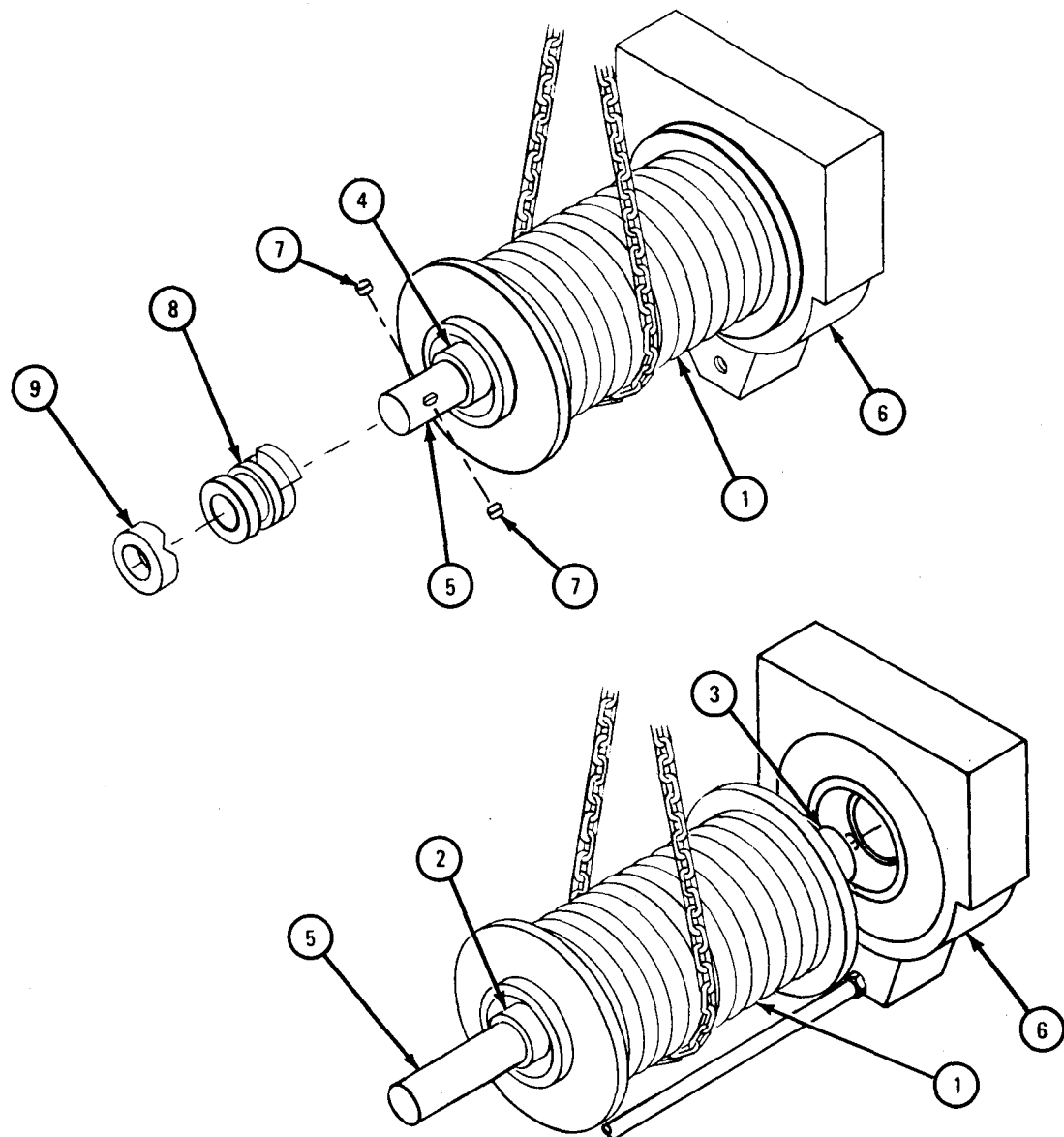

TA 101077

FRAME 7

1. If shifter shaft oil seal (1) was taken out, press new seal into end frame (2).
2. Hold shifter yoke (3) in place in end frame (2). Aline woodruff key (4) with keyway in yoke and put shifter shaft (5) through oil seal (1) and yoke.
3. Put in setscrew (6).

GO TO FRAME 8

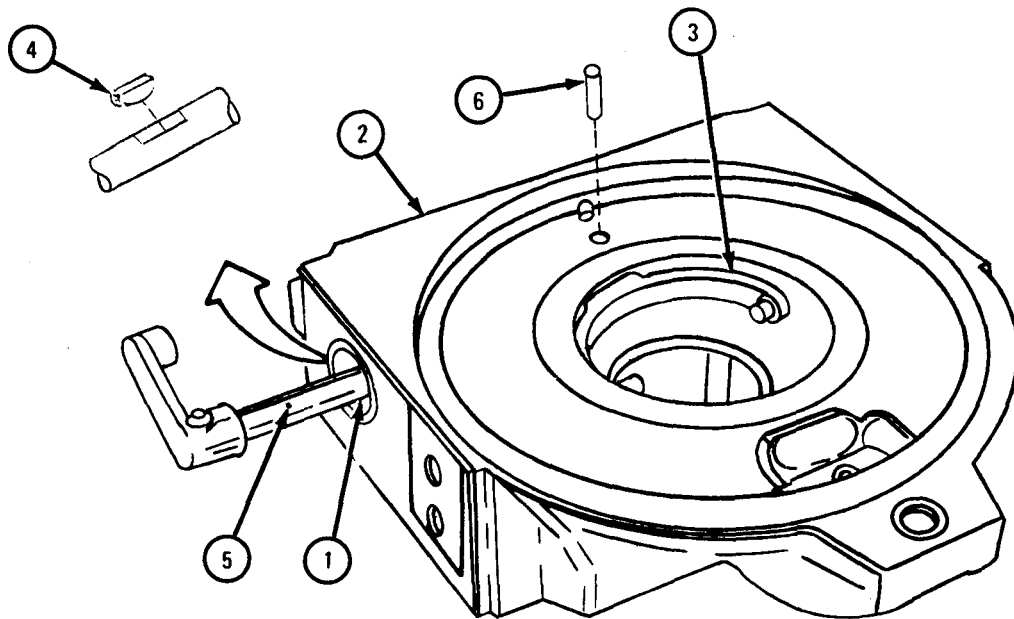

TA 101078

FRAME 8

- 1. Put spacer (1) on poppet (2).
- 2. Put spring (3), bolt (4), and latch (5) on poppet (2).
- 3. Put two nuts (6) on poppet (2).

GO TO FRAME 9

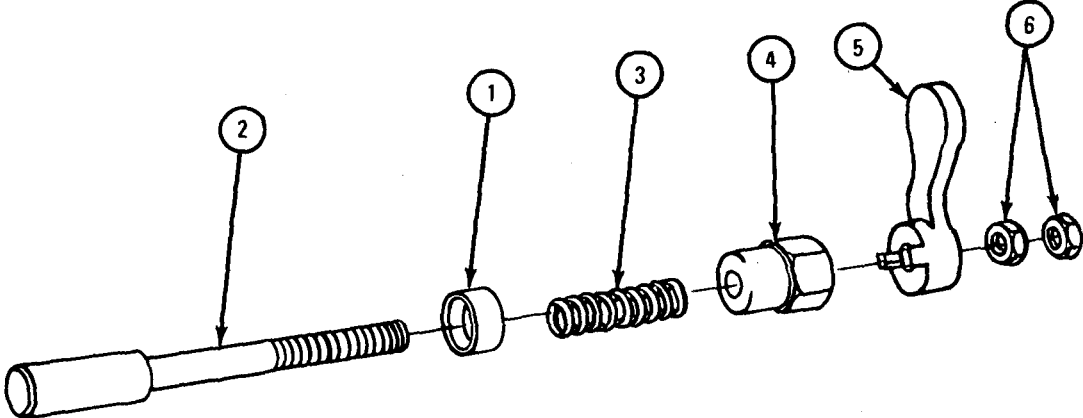

TA 101079

FRAME 9

1. If oil seal (1) was taken out, press new seal into end frame (2).
2. Put in drum lock assembly (3).
3. Put in plugs (4 and 5).
4. Put drag brake with lining assembly (6) into end frame (2). Put in adjusting screw (7).
5. Put bearing with sleeve assembly (8) into end frame (2). Aline bearing with dowel pin (9).

GO TO FRAME 10

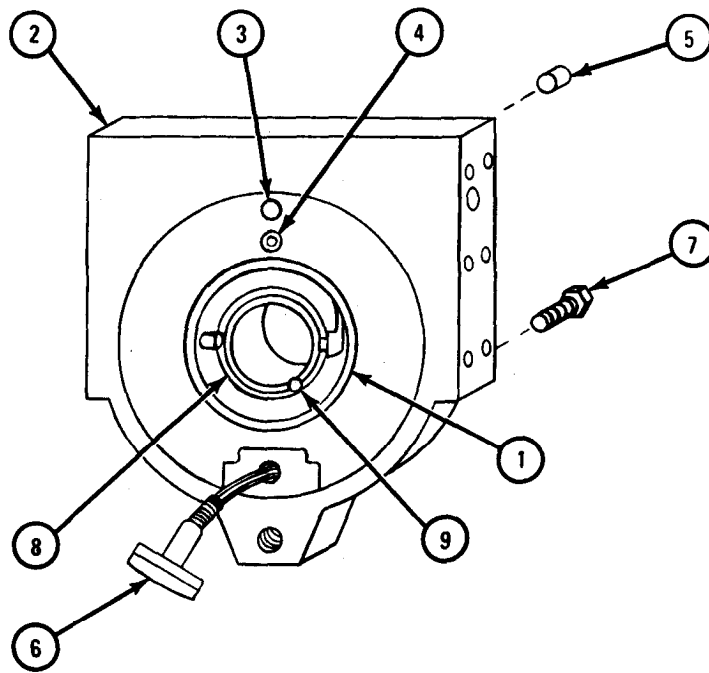

TA 101080

FRAME 10

1. Using hoist, hold drum (1) and gearcase (2) and put end frame (3) in place on drum. Make sure that clutch shifter yoke (4) in end frame (3) meshes with drum sliding clutch (5) on drumshaft (6).
 2. Put tie rod (7) into mounting hole in end frame (3).
 3. Put on nut (8) to hold end frame (3), drum (1), and gearcase (2) together.
- GO TO FRAME 11

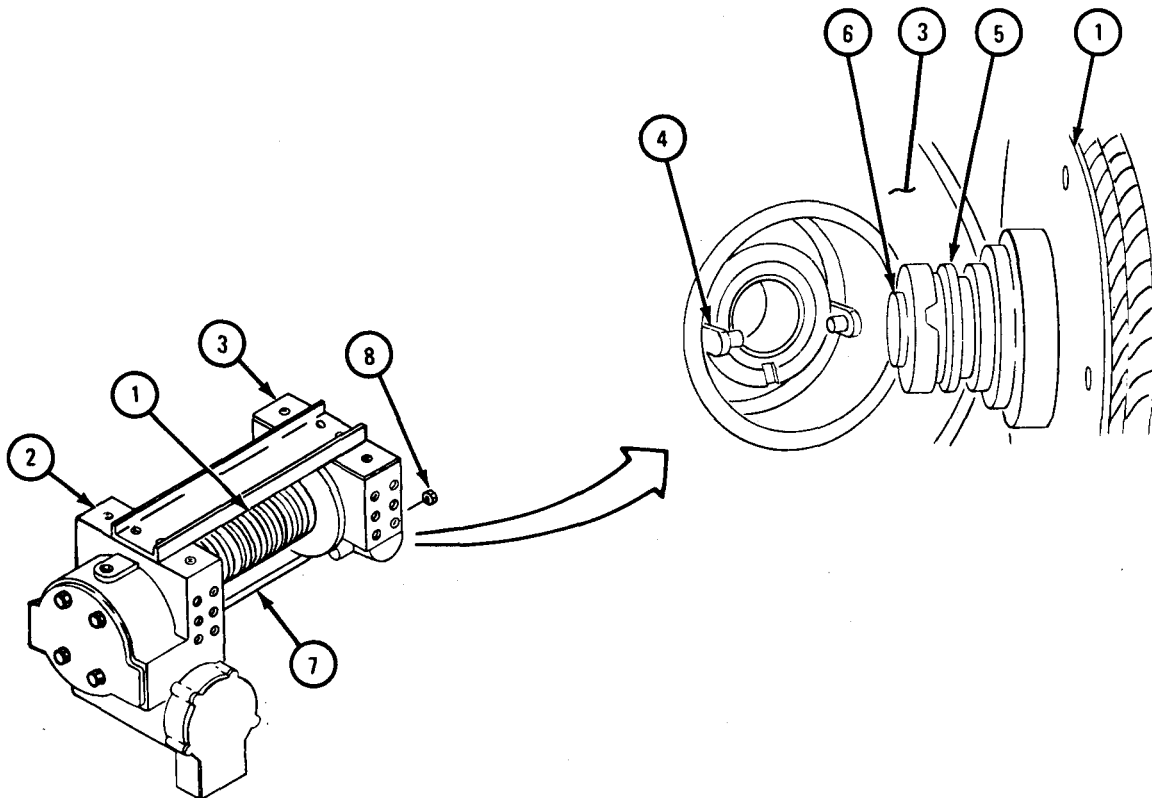

TA 101081

FRAME 11

1. Put channel (1) in place on gearcase (2) and end frame (3).
 2. Put in four capscrews and washers (4).
 3. Put channel (5) on gearcase (2) and end frame (3).
 4. Put on four capscrews and washers (6).
 5. Tighten nut (7) holding tie rod (8) to end frame (3).
 6. Put in drain plugs (9).
 7. Fill rear winch with gear lubricating oil. Refer to LO 9-2320-209-12/1.
- GO TO FRAME 12

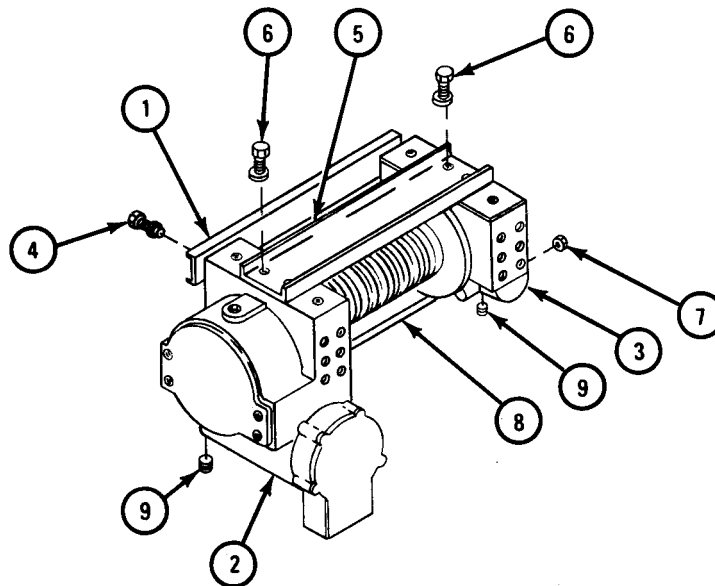

TA 101082

FRAME 12

1. Put fitting (1) on sprocket (2).
2. Press bushing (3) on sprocket (2), alining pin holes.
3. Put sprocket (2) on hub (4) and hold it in place.
4. Put two retaining rings (5) on hub (4).
5. Put hub (4) with bushing (3) and sprocket (2) on shaft (6), alining holes.
6. Put straight pin (7) through sprocket (2), bushing (3), and hub (4).
7. Put in expansion plug (8).
8. Put shear pin (9) through hub (4) and sprocket (2).
9. Put in cotter pin (10).
10. Grease rear winch sprocket. Refer to LO 9-2320-209-12/1.

END OF TASK

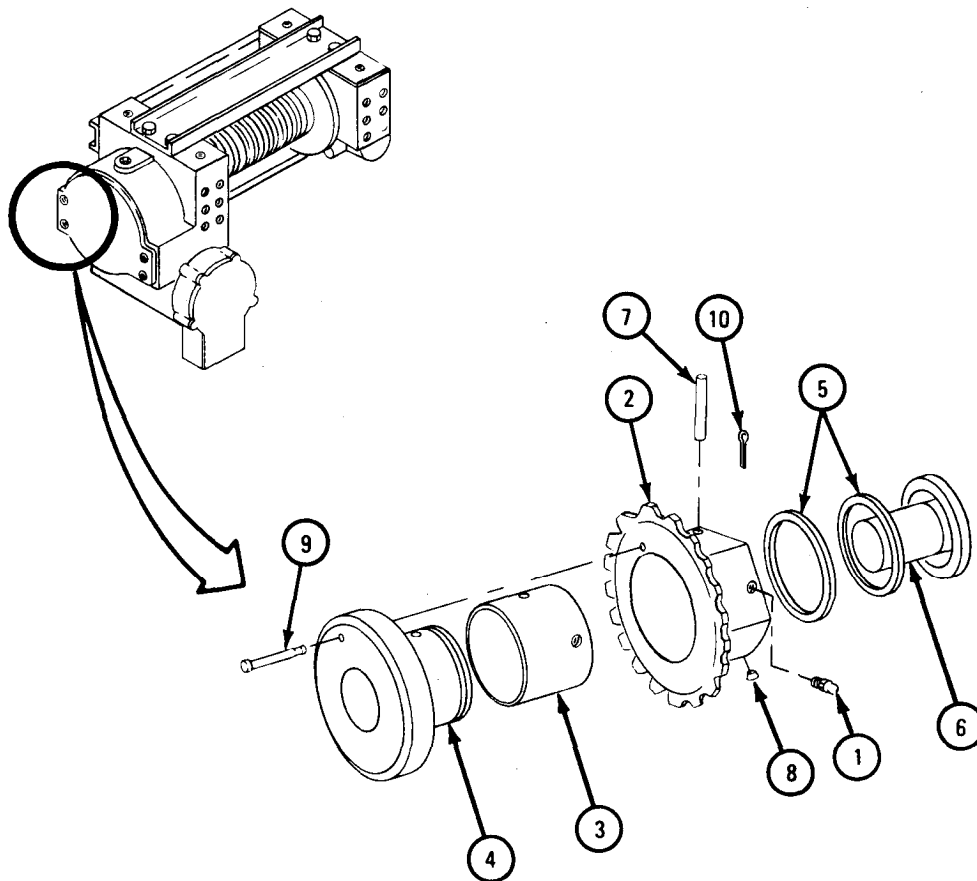

TA 101083

9. Replacement.

FRAME 1

1. Using hoist, lower rear winch (1) onto mounting frame (2) and hold weight of winch.
 2. Put in four capscrews (3) and washers (4) on left bracket (5).
 3. Put in four capscrews (6) and washers (7) on right bracket (8).
 4. Unhook hoist.
- GO TO FRAME 2

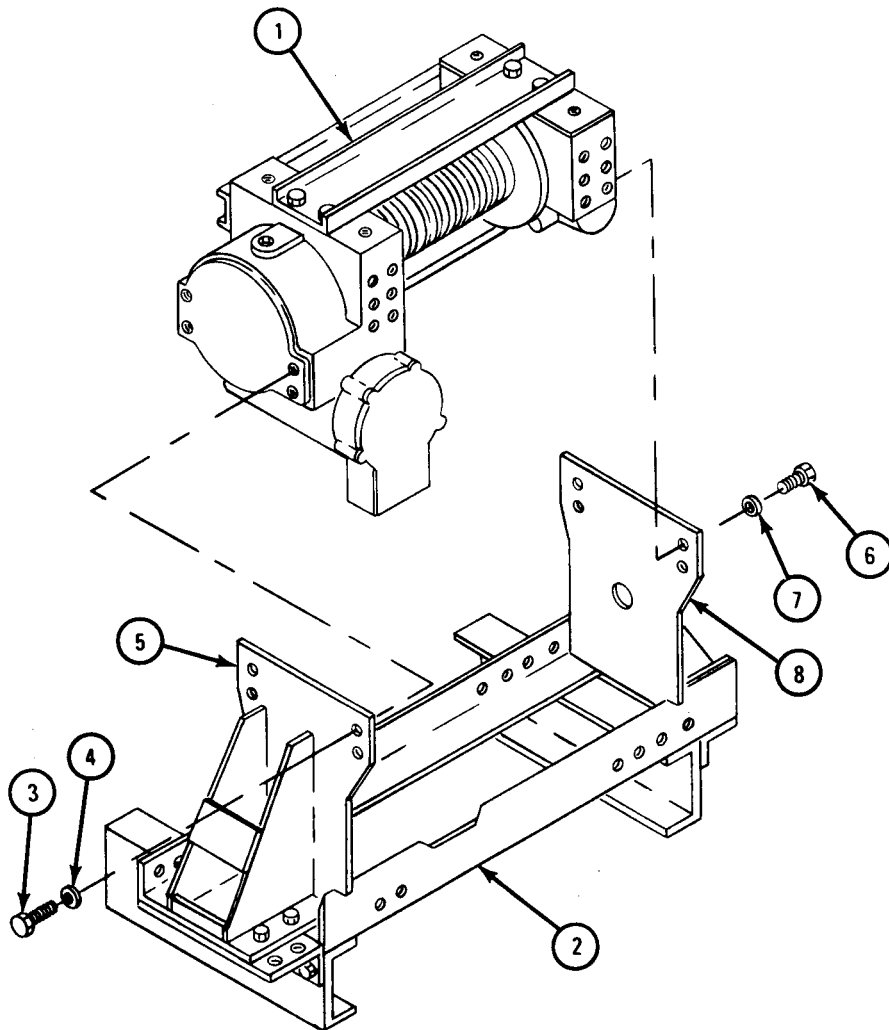

TA 101084

FRAME 2

1. Place drive chain (1) around sprockets (2 and 3).
2. Put in pin (4).
3. Put on master link (5).
4. Put on master link cap (6).
5. Put cotter pin (7) in each of two pins in master link (5).

NOTE

Follow-on Maintenance Action Required:

Replace cab protector. Refer to TM 9-2320-20

END OF TASK

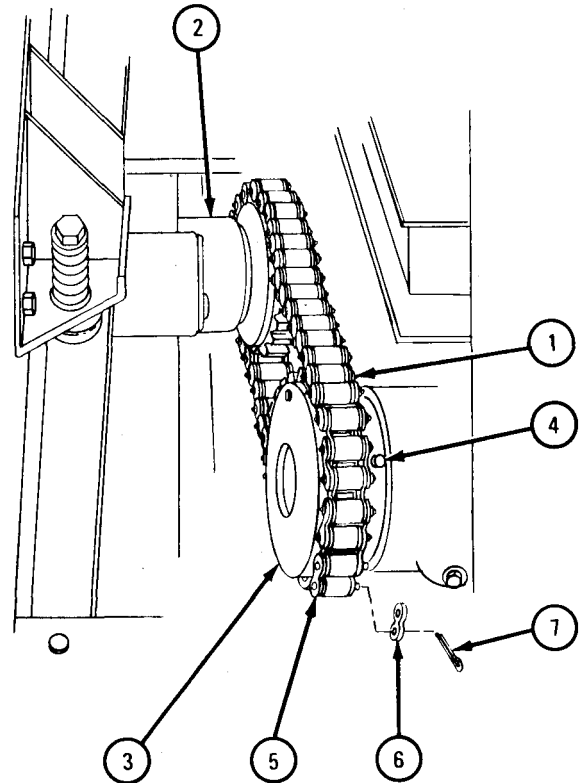
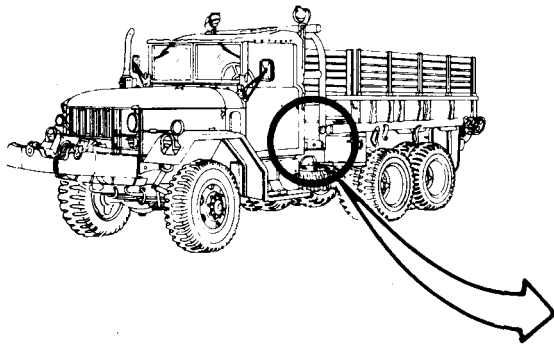

TA 101086

h. Test.

FRAME 1

WARNING

Always wear leather gloves when handling winch cable. Never allow cable to run through hands. Rusty or broken wires can cause serious injury to personnel.

NOTE

Test rear winch mounted on the truck. To operate winch, refer to TM 9-2320-209-10.

1. Pull out drum lock knob (1) and turn it 90° to the unlocked position.
2. Put drum clutch lever (2) toward center of truck.

Soldier A

3. Pull on cable (3) and then stop pulling.

Soldier B

4. Check that winch drum stops turning. If winch keeps turning, turn adjusting screw (4).

Soldiers A and B

5. Do steps 3 and 4 until winch drum stops turning when cable (3) is no longer pulled.

GO TO FRAME 2

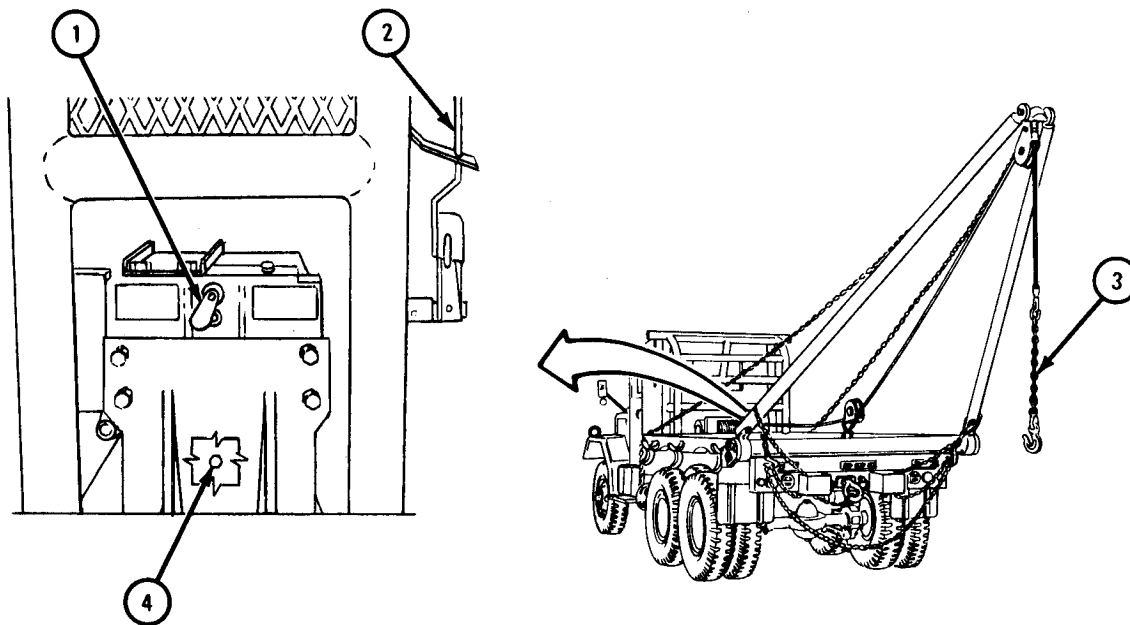

TA 101087

FRAME 2

- Soldier A 1. Put a load (1) on end of cable (2).
- Soldier B 2. Put winch clutch lever (3) toward center of truck.
 3. Check that drum lock knob (4) is in unlocked position.
- Soldier A 4. Start winch. Refer to TM 9-2320-209-10.
- Soldier B 5. Put winch clutch lever (3) toward right side of truck.
- Soldier A 6. Raise load (1) with winch, then stop winch. Refer to TM 9-2320-209-10. Winch must hold load.
- Soldier B 7. If winch does not hold weight (1), tighten adjusting screw (5) 1/2 turn.
- Soldiers A and B 8. Do steps 2 through 6 again until winch holds load (1).
9. If automatic brake overheats, loosen brake adjusting screw (5) 1/2 turn.

END OF TASK

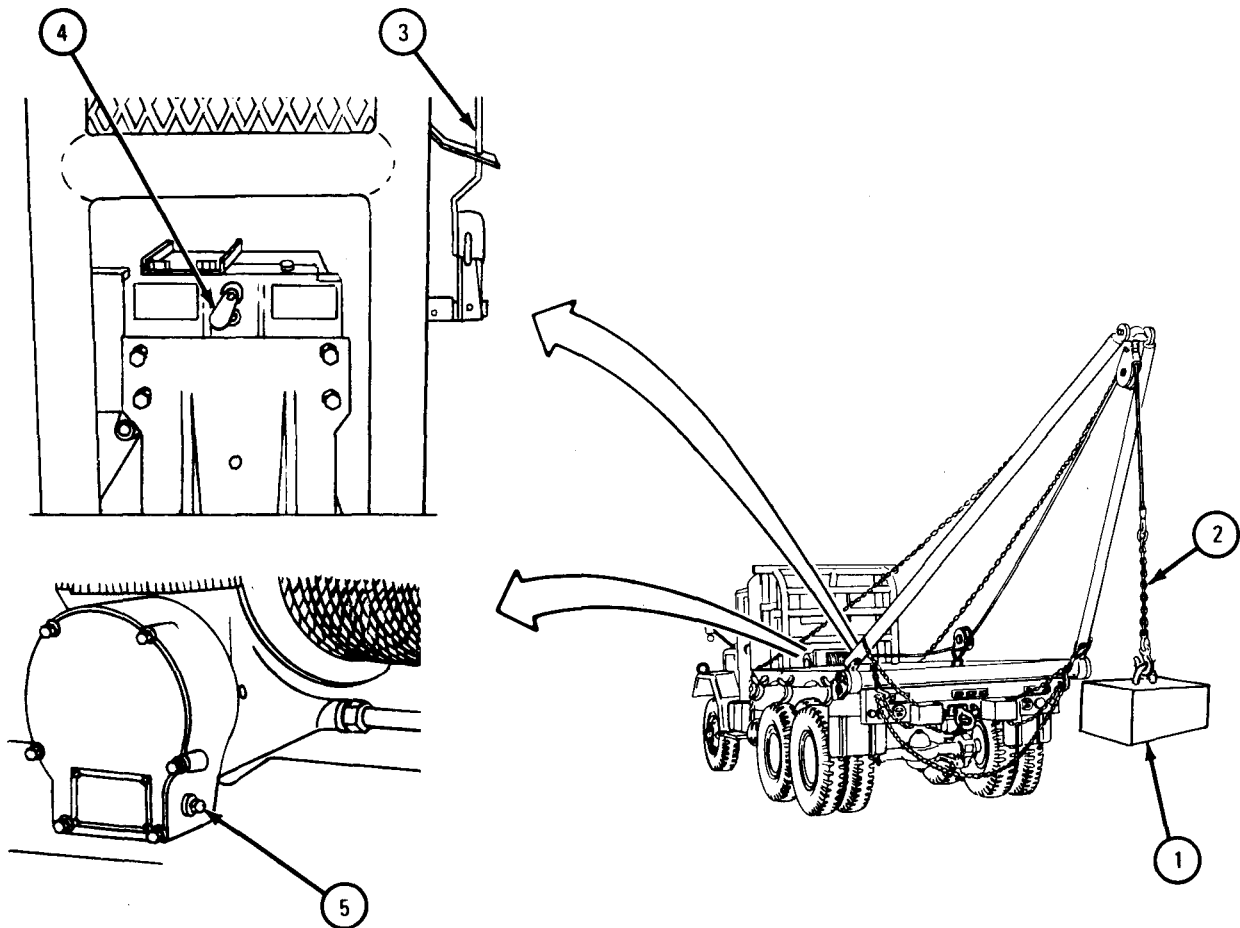

TA 101088

18-5. REAR WINCH REMOVAL, REPAIR, AND REPLACEMENT (TRUCK M764).

TOOLS: No special tools required

SUPPLIES: Lubricating grease, type GAA, MIL-G-10924
Lubricating oil, ICE, OE/HDO 10, MIL-L-2104
Lubricating oil, GO 80/90, Universal
Honing stone
Crocus cloth, type J
Artus shim stock or equivalent
Felt washer, pn 11623070 (2)
Gasket, pn 7701753 (2)
Gasket, pn 7701749 (3)
Seal, pn 500156
Seal, pn 11621388
Shear pin, pn 11609886 (3)
Link assembly, pn 11623139-2 (2)
Spring clip, pn 11609932-2 (2)
Rivet, pn MS20613-8P28
Taper pin, pn MS24692-331

PERSONNEL: Two

EQUIPMENT CONDITION: Truck parked, engine off, handbrake set.

a. Preliminary Procedures.

- (1) Remove cab protector. Refer to TM 9-2320-209-20.
- (2) Remove power divider. Refer to para 18-12.
- (3) Remove winch drive chain. Refer to para 18-6.
- (4) Remove reduction drive chains. Refer to TM 9-2320-209-20.
- (5) Remove winch cable. Refer to TM 9-2320-209-20.
- (6) Remove carriage cross chains. Refer to TM 9-2320-209-20.

b. Removal.

FRAME 1

1. Take out cotter pin and clevis pin (1) joining control rod (2) to eyebolt (3). Throw away cotter pin.
2. Take off four capscrews (4) and cover (5) from right-hand body side panel.
3. Take out eight capscrews, washers, and nuts (6) joining worm housing (7) to mounting frame (8).

GO TO FRAME 2

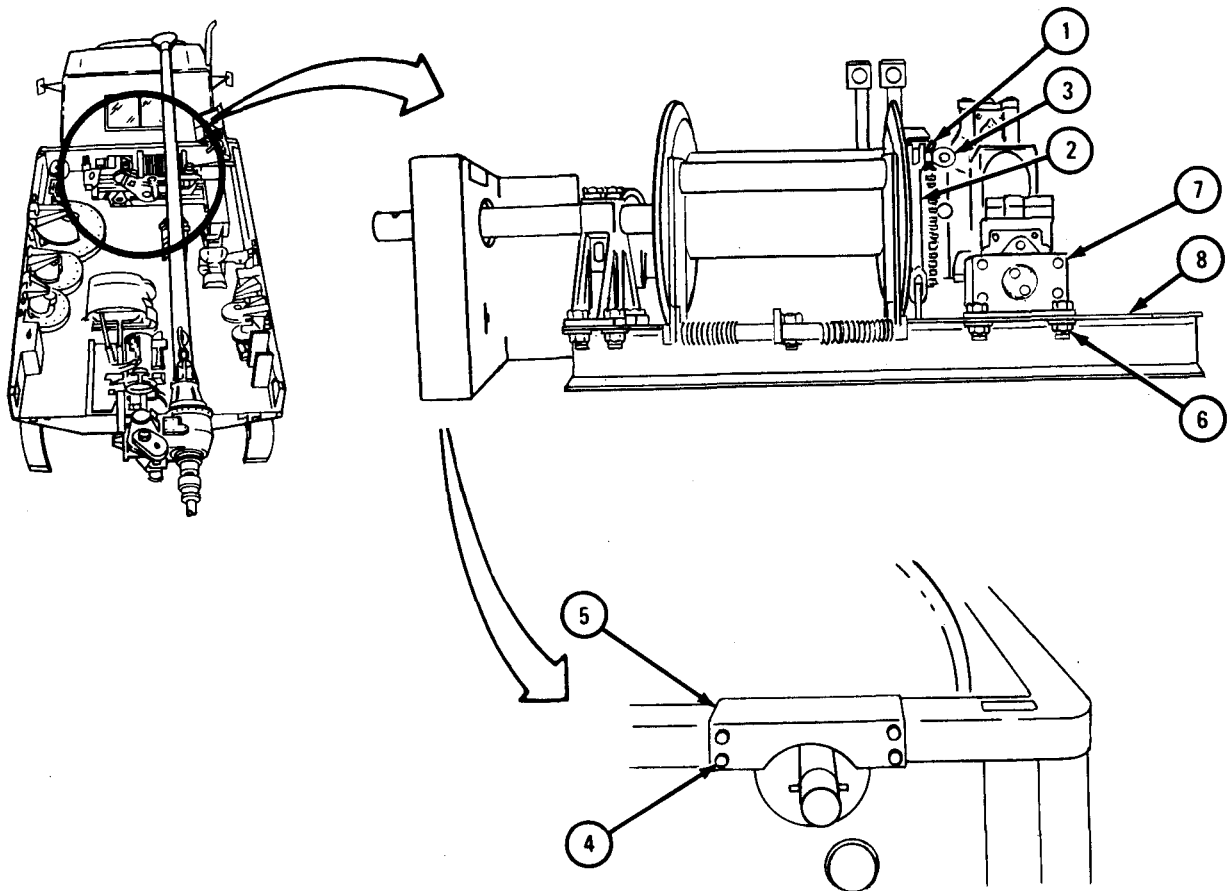

TA 089068

FRAME 2

1. Place lifting chains around drum shaft. Mate lifting chains to a hoist.
2. Take out eight screws, washers, and nuts (1) joining drumshaft support (2) to mounting frame (3).

WARNING

Cable tensioner (6) is spring-loaded. When winch assembly is raised, the tensioner will drop to unloaded position. Always stand away when raising winch assembly (4). The cable tensioner can snap back and cause injury to personnel.

- Soldier A 3. Guide rear winch (4) off truck and onto work table as soldier B lifts it.
- Soldier B 4. Lift rear winch (4) off truck.
5. Take out three screws, washers, and nuts (5), joining cable tensioner (6) to mounting frame (3).
 6. Take off cable tensioner (6).

END OF TASK

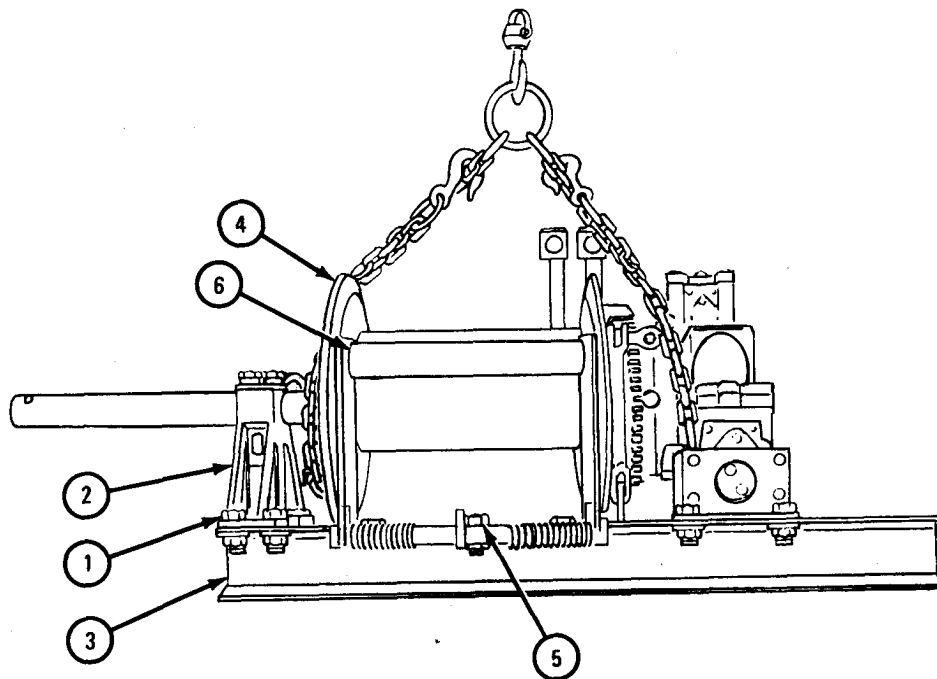

TA 089069.

c. Disassembly.

FRAME 1

NOTE

Idler pulley and bracket assembly were removed during preliminary tasks.

1. Take out and throw away cotter pin (1).
2. Take off nut and outer bearing retainer (2).
3. Take off seal (3).

NOTE

Do not take lubricating fitting out of outer bearing retainer (2).

4. Using a puller, take off idler pulley (4).

NOTE

Do not take out two bearing cups (6) unless inspection calls for replacement.

5. Take two tapered roller bearings (5) out of idler pulley (4).
6. Leave two retaining rings (7) in idler pulley (4).
7. Take off seal (8).
8. Shaft (9) and inner bearing retainer (10) are welded together with spacer and mounting plate. If there is damage to any of these parts, get new assembly. Refer to para 18-5e, for inspection procedures.

GO TO FRAME 2

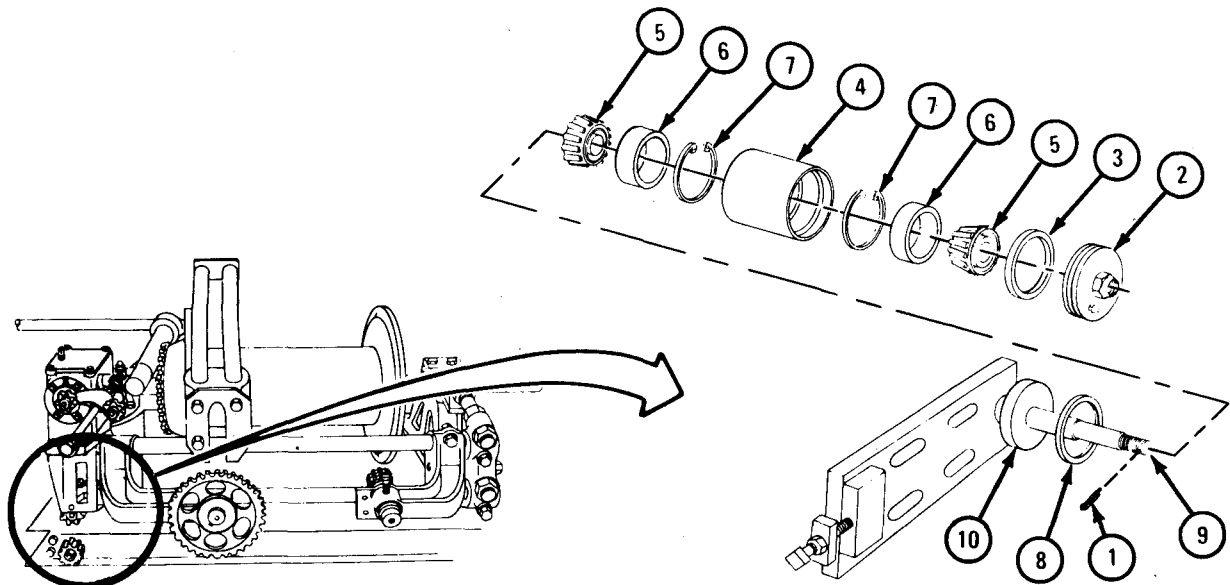

TA 089070

FRAME 2

1. Loosen setscrew (1) on sprocket (2).
2. Pull sprocket (2) off shaft (3).
3. Take key (4) off shaft (3).
4. Take off two nuts (5) and washer (6).
5. Take off bracket assembly (7).

NOTE

Measure the amount of threads showing on adjusting rod (8). Note measurement.

6. Take off screw (9) and two washers (10).
7. Slide adjusting rod (8) from bracket assembly (7).

GO TO FRAME 3

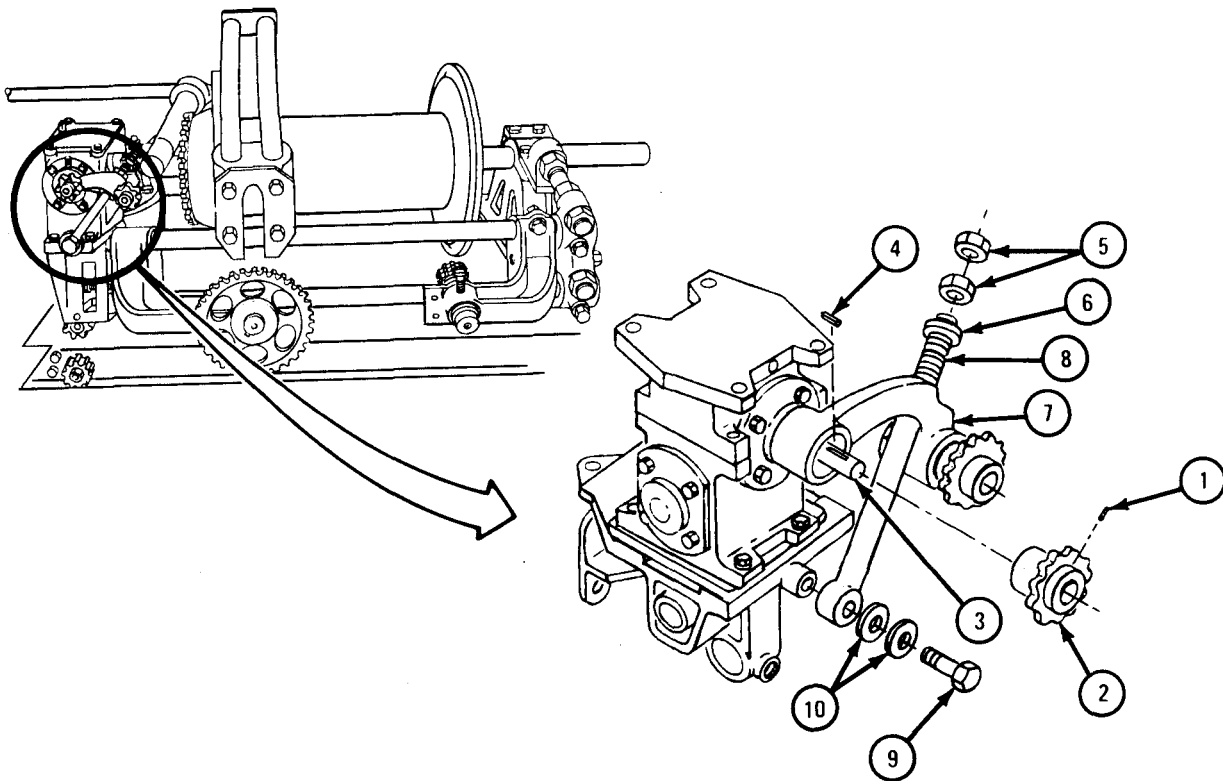

TA 089071

FRAME 3

1. Loosen setscrews (1) from collar (2).
2. Take off collar (2) from shaft (3).
3. Pull sprocket (4) with shaft (3) from bracket (5).

NOTE

If shaft (3) or sprocket (4) is damaged, pull apart shaft from sprocket. Refer to para 18-5e for inspection procedures.

4. Take off setscrew (6) from sprocket (4) and press shaft (3) off sprocket. Take key (7) off shaft.

NOTE

Do not take out bushings (8 and 9) from bracket (5) unless they are damaged. Refer to para 18-5e for inspection procedures.

5. Take out bushings (8 and 9) from bracket (5).

GO TO FRAME 4

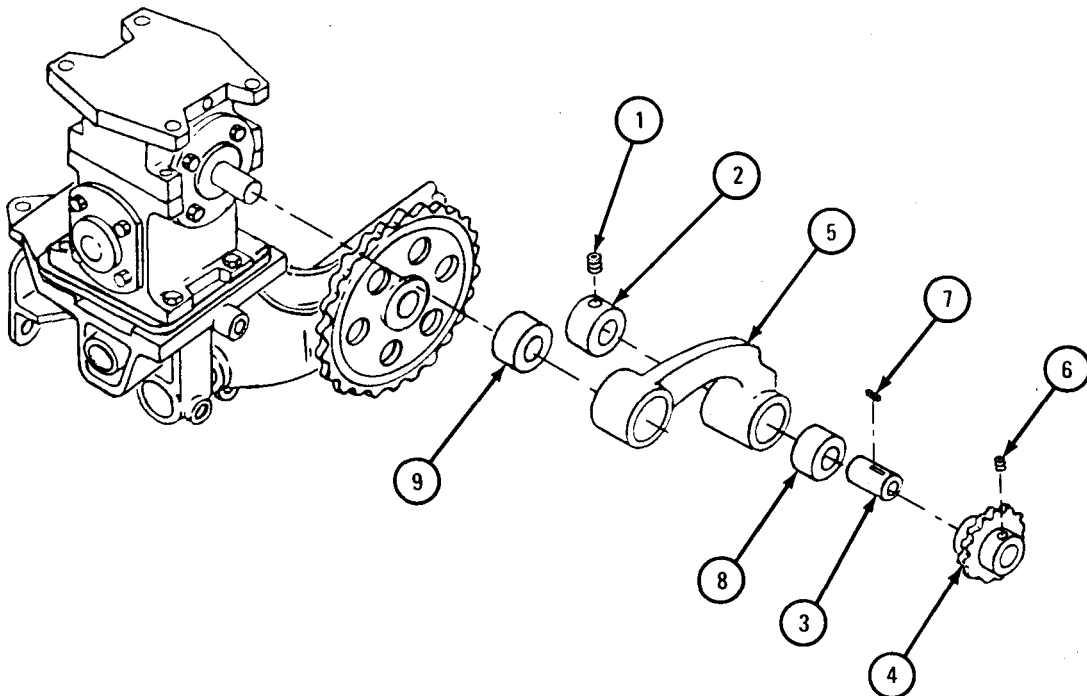

TA 089072

FRAME 4

1. Loosen setscrew (1) on sprocket (2). Pull sprocket off shaft (3).
2. Take out two keys (4).
3. Slide bracket (5) off shaft (3).
4. Loosen setscrew (6) on collar (7). Pull collar off shaft (8).
5. Pull sprocket (9) with shaft (8) from bracket (5).

NOTE

If shaft (8) or sprocket (9) is damaged, pull apart shaft from sprocket. Refer to para 18-5e for inspection procedures.

6. Take off setscrew (1) from sprocket (9) and press shaft (8) off sprocket.

NOTE

Do not take out two bushings (10) from bracket (5) unless they are damaged. Refer to para 18-5e for inspection procedures.

7. Take out two bushings (10) from bracket (5).

GO TO FRAME 5

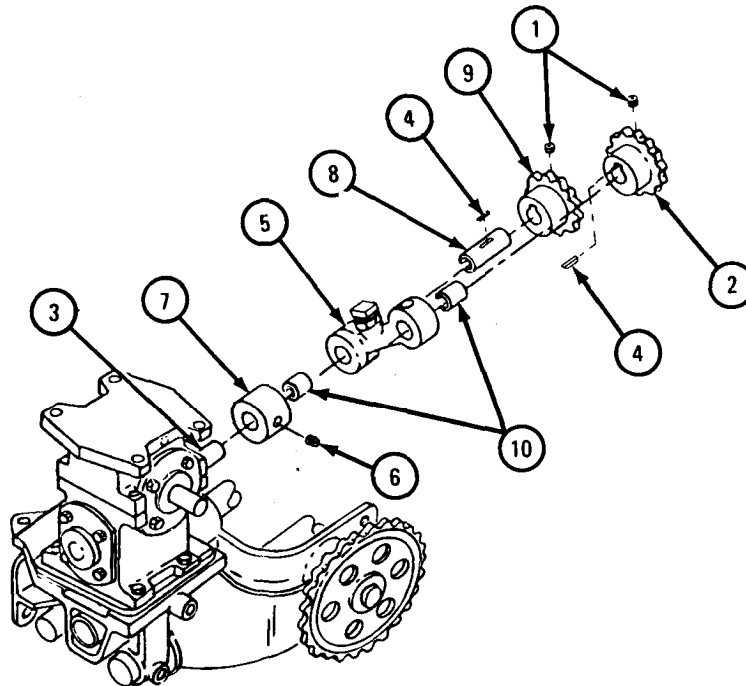

TA 089073

FRAME 5

1. Take out four capscrews and washers (1) that hold speed reducer assembly (2) to mounting plate (3).
2. Lift off speed reducer assembly (2).
3. Take out two capscrews (4) and two capscrews with washers (5).
4. Lift off mounting plate (3).
5. Connect hoist to upper and lower carriage tie rods (6). Hold up weight of assembly.
6. Take out two capscrews and washers (7).
7. Take out capscrew (8), lockwasher (9), and flat washer (10).

GO TO FRAME 6

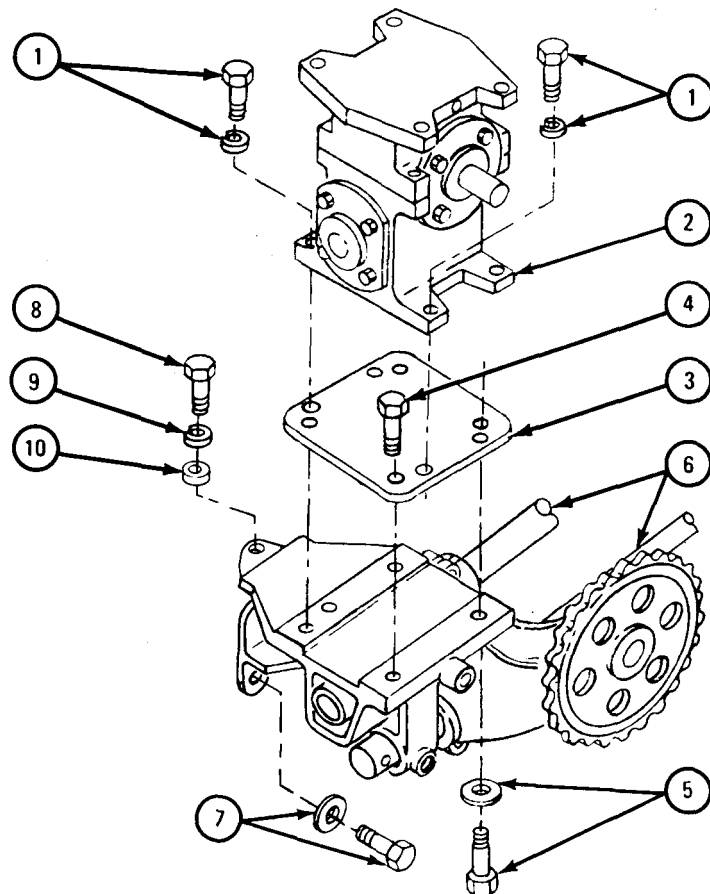

TA 089074

FRAME 6

1. With hoist still joined to upper and lower carriage tie rods (1), take off nut (2) and washer (3).
2. Take out two capscrews (4) and washers (5) holding support (6).
3. Lift off carriage and tie rod assembly and place on work bench.
4. Take out nut, washer, and capscrew (7) from support assembly (8).
5. Take off nuts (9) and capscrews (10), holding tie rods (1) to support assembly (8).
6. Slide support assembly (8) off tie rods (1).

GO TO FRAME 7

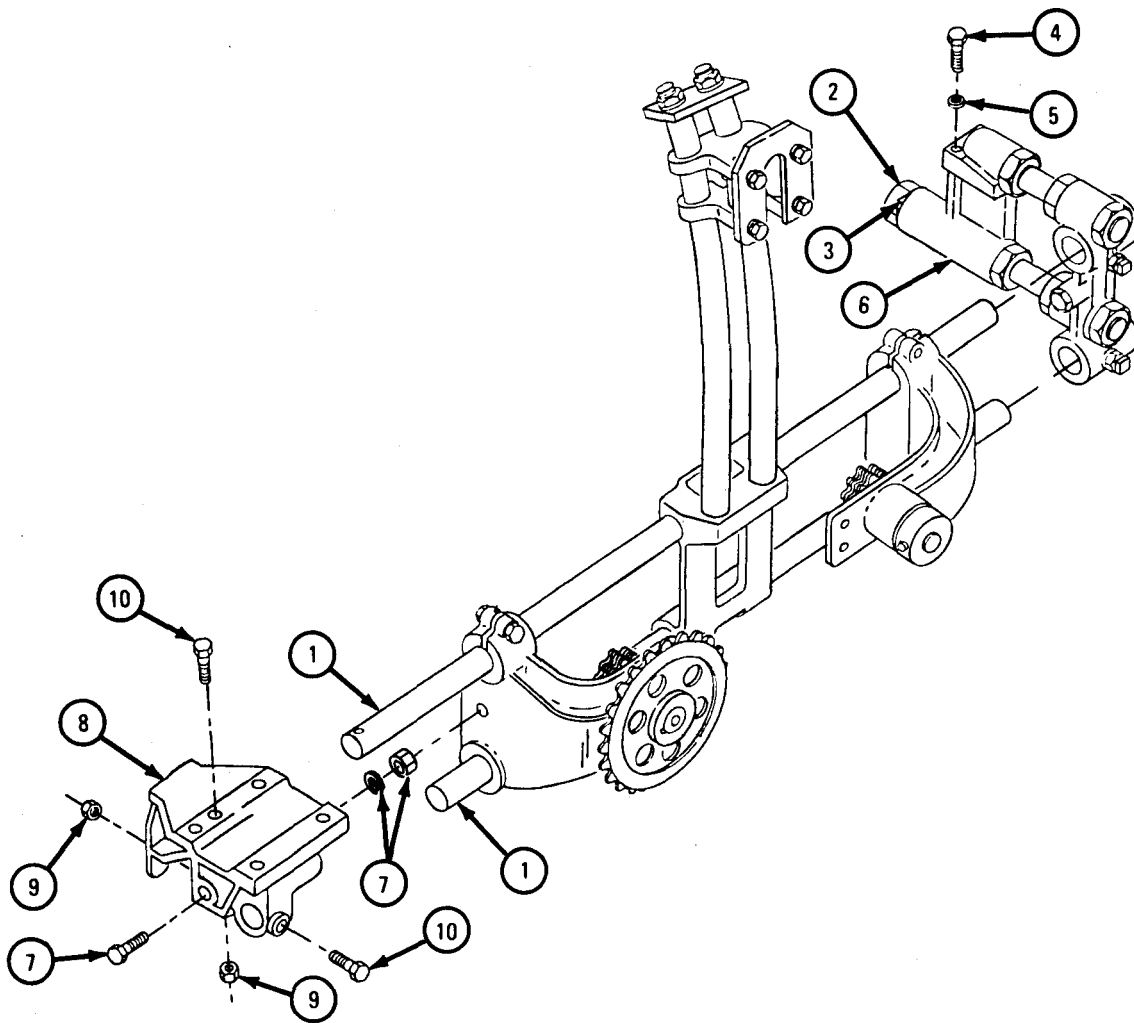

TA 089075

FRAME 7

1. Take out setscrew (1) from sprocket (2).
2. Pull sprocket (2) from shaft portion of sprocket (3).
3. Take out key (4).
4. Remove sprocket (3) and washer (5) from bracket (6).

NOTE

Do not take bushing (7) from bracket (6) unless it is damaged. Refer to para 18-5e for inspection procedures.

5. Take out bushing (7) from bracket (6).
6. Take out four capscrews and washers (8) holding guide plates (9) to carriage assembly (10).
7. Take off two guide plates (9).

GO TO FRAME 8

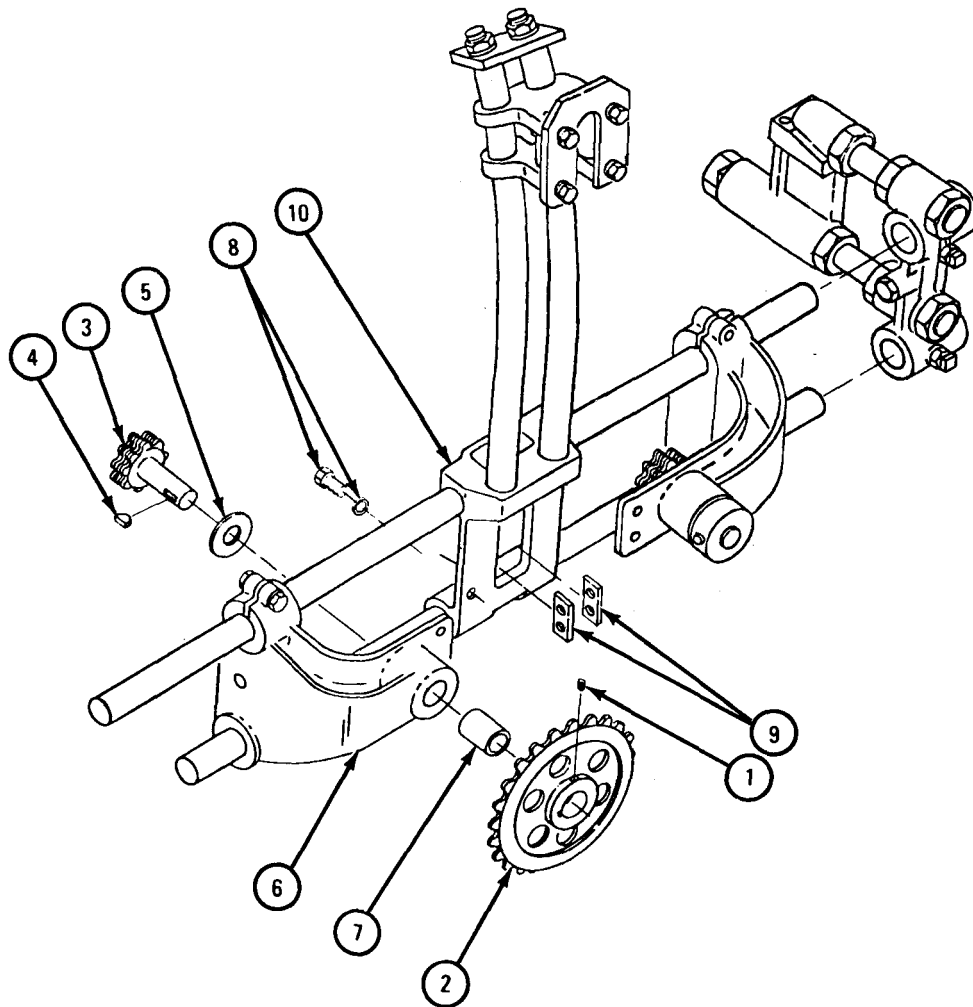

TA 089076

FRAME 8

1. Take out setscrew (1) from collar (2).
2. Take off collar (2) from shaft portion of sprocket (3).
3. Take off sprocket (3) and washer (4) from bracket (5).

NOTE

Do not take out bearing (6) from bracket (5) unless it is damaged. Refer to para 18-5e for inspection procedures.

4. Take out bearing (6) from bracket (5).
5. Take out two capscrews, washers and nuts (7).
6. Slide bracket (8) off tie rods (9).

GO TO FRAME 9

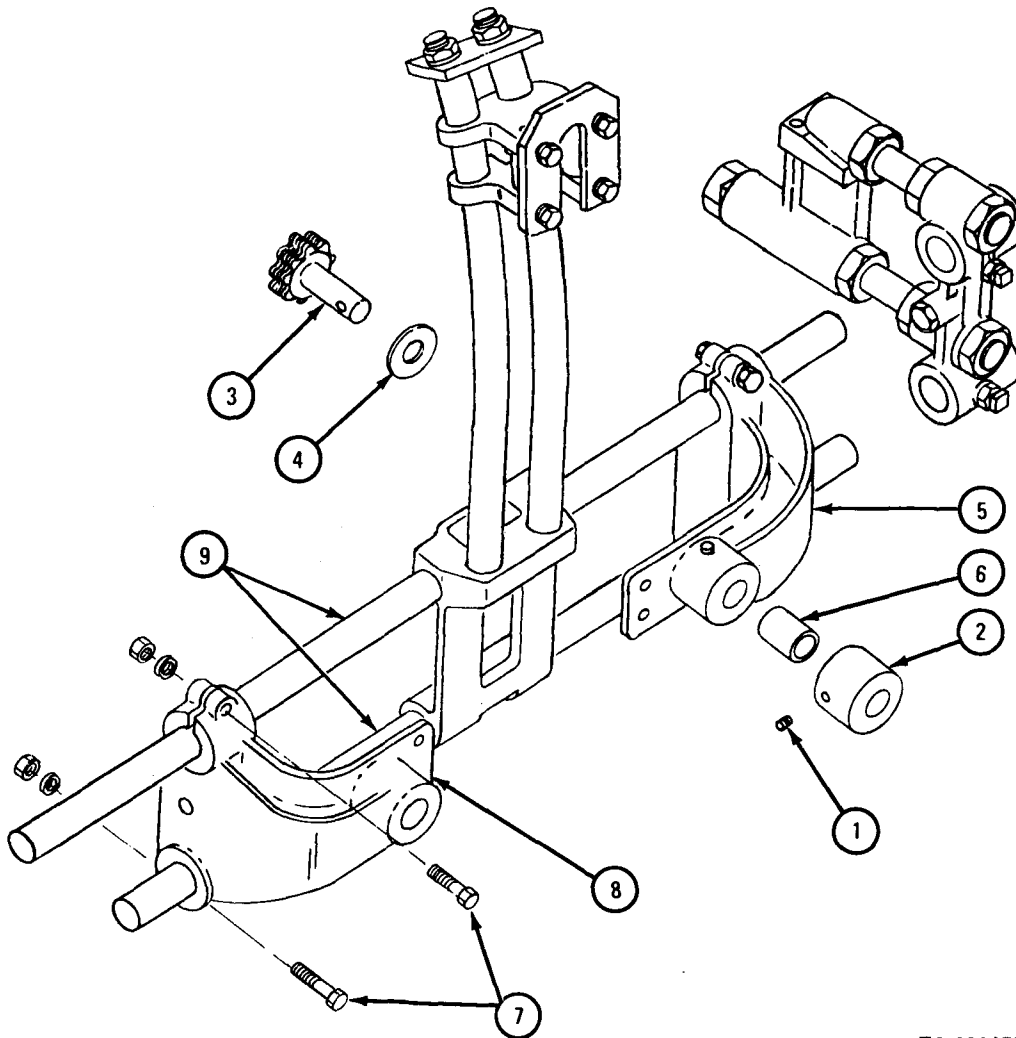

TA 089077

FRAME 9

1. Slide carriage assembly (1) off tie rods (2).
2. Take off two nuts and washers (3).
3. Lift plate (4) off carriage horns (5).
4. Slide roller cage assembly (6) off top of carriage horns (5).
5. Loosen two setscrews (7) in tie rod support (8).
6. Slide tie rod support (8) with mating parts off tie rods (2).

NOTE

No parts are available for repair of tie rod (8) and mating parts.

7. Take out two capscrews, washers, and nuts (9).
8. Slide off tie rods (2).
9. Take out two auxiliary vertical rollers (10).

GO TO FRAME 10

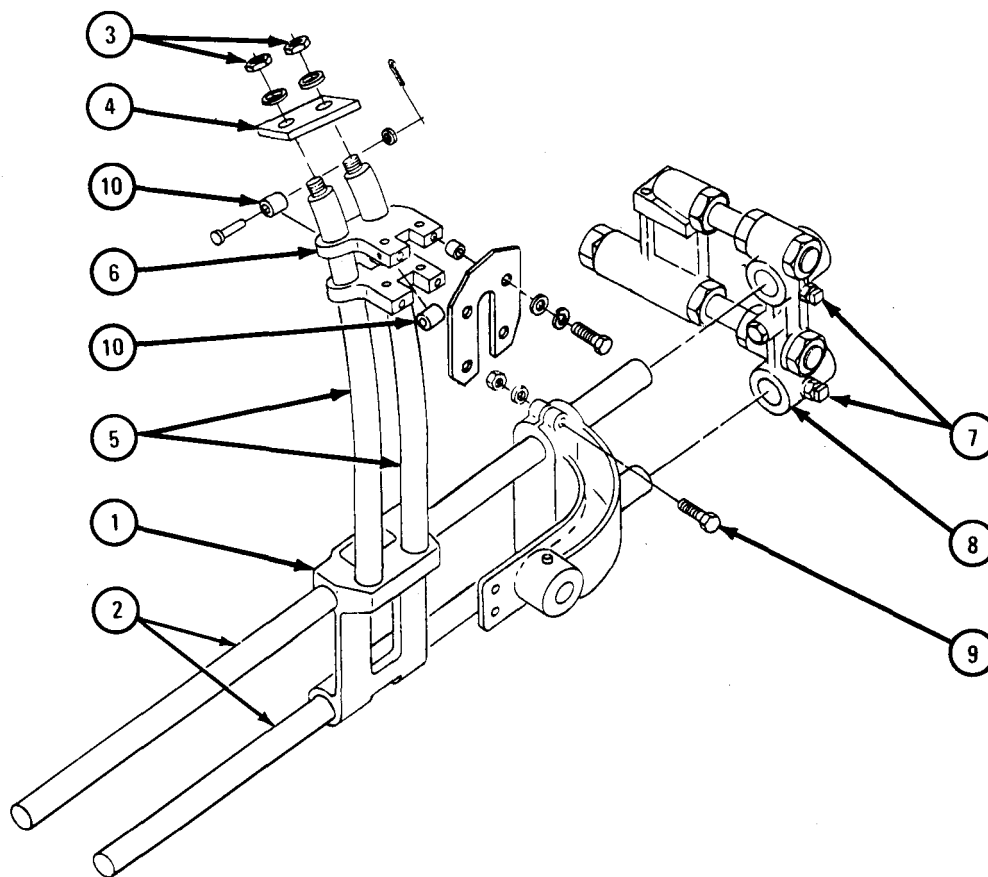

TA 089078

FRAME 10

1. Take off four capscrews (1), lockwashers (2), and flat washers (3) from roller guard (4).
 2. Lift off roller guard (4) and spacers (5) from roller cage (6).
 3. Take out and throw away cotter pins (7).
 4. Take out two shafts (8), rollers (9), and bearings (10) from roller cage (6).
- GO TO FRAME 11

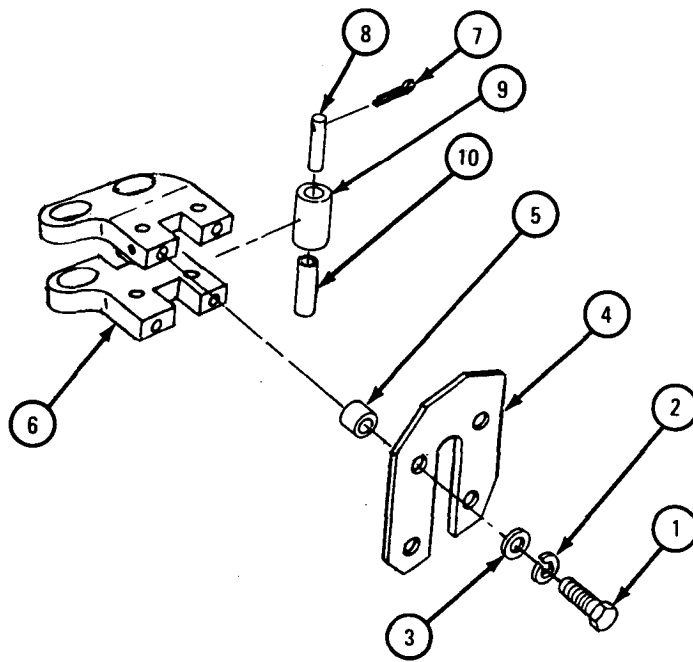

TA 089079

FRAME 11

1. Take off two capscrews and washers (1) holding drumshaft cap (2) to drumshaft support (3).
2. Take apart drumshaft cap (2) from drumshaft support (3).

GO TO FRAME 12

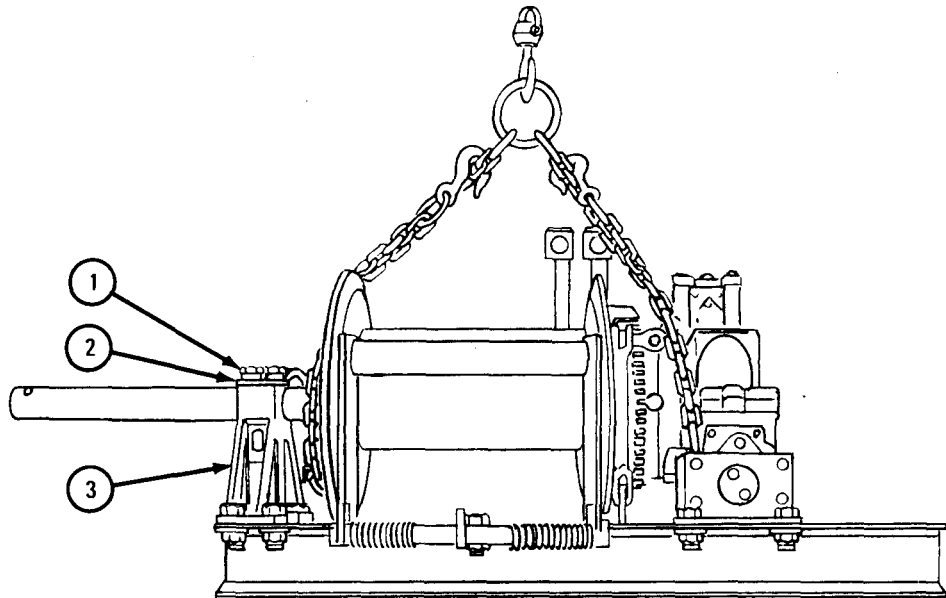

TA 089080

FRAME 12

1. Take out two capscrews and washers (1) holding shifter fork assembly (2) to worm housing cover (3).
2. Take off shifter fork assembly (2) and washers (4). Be sure not to lose washers (4) between bracket and cover.
3. Take off three capscrews (5) and washers (6).
4. Lift cover (3) off worm housing (7) and throw away gaskets (8).
5. Take off one bushing reducer and air valve (9) from cover (3).
6. Using a hoist, lift shaft and drum assembly (10) off worm housing (7).
7. Drain oil from worm housing (7).
8. Take two pins (11) from cover (3).

GO TO FRAME 13

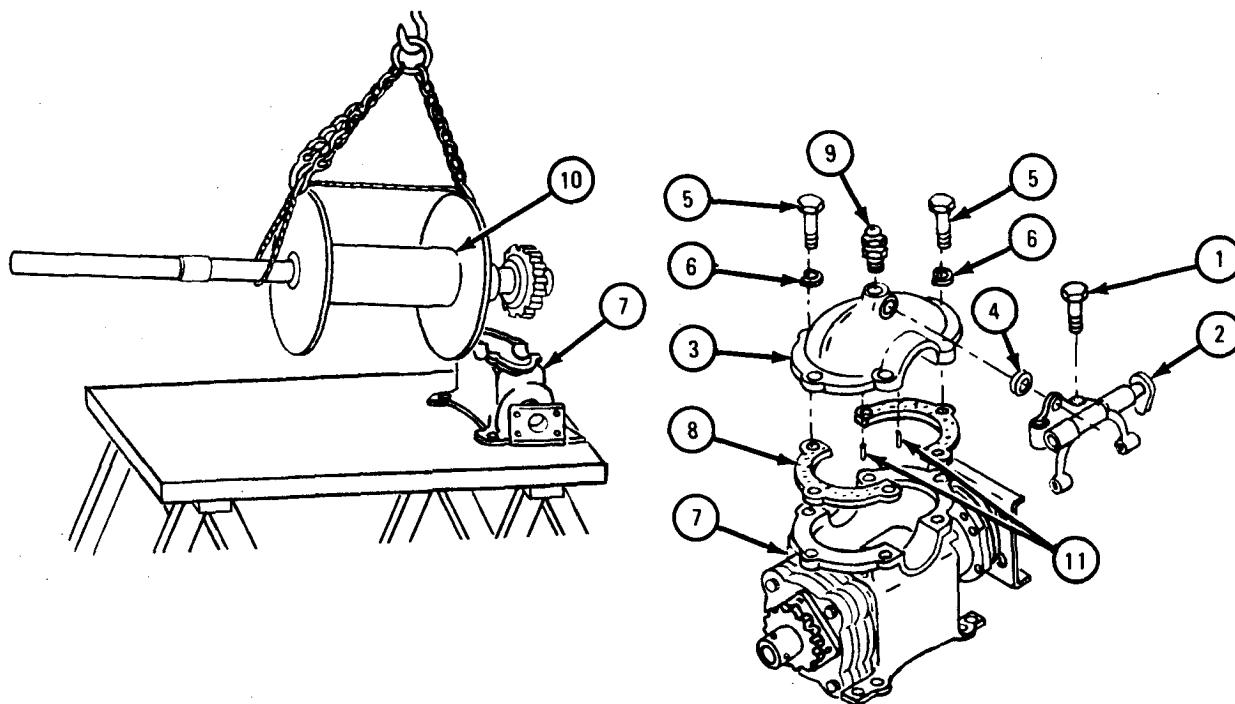

TA 089081

FRAME 13

1. Take out tapered pin (1) from control lever (2).
2. Take off control lever (2) from shaft (3).
3. Take out rivet (4) from fork (5).
4. Slide shaft (3) out, to take off fork (5) from bracket (6).
5. Take off key (7).
6. Take out two straight pins (8).

NOTE

Do not remove lubrication fitting (9) from bracket (6).

GO TO FRAME 14

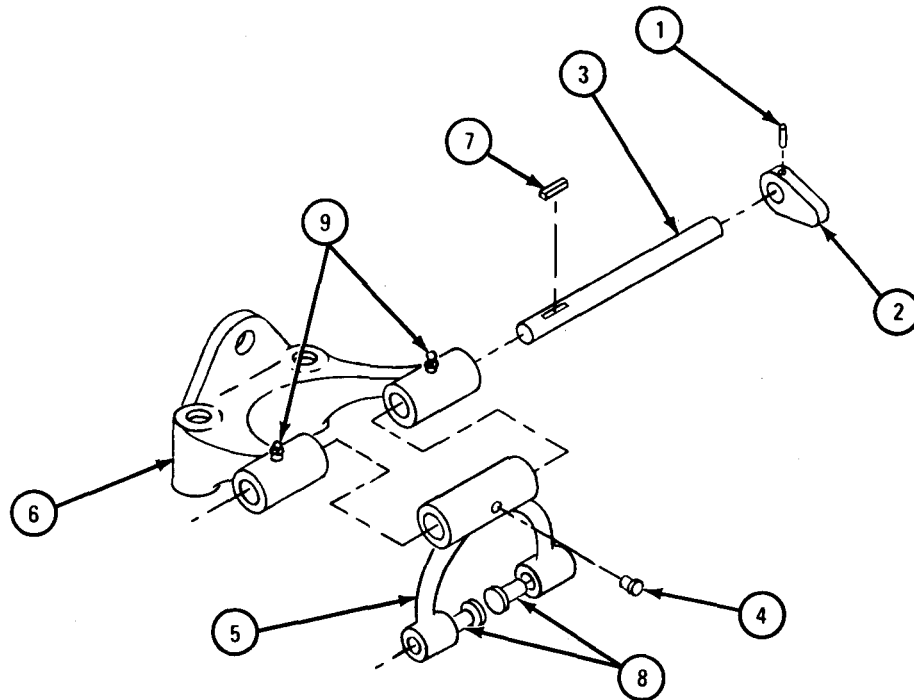

TA 089082

FRAME 14

1. Takeout pins (1 and 2).
2. Slide bushing (3) and collar (4) on shaft (5) toward pin (6).
3. Slide drum (7) on shaft (5) toward pin (8).
4. Take out pin (8).

GO TO FRAME 15

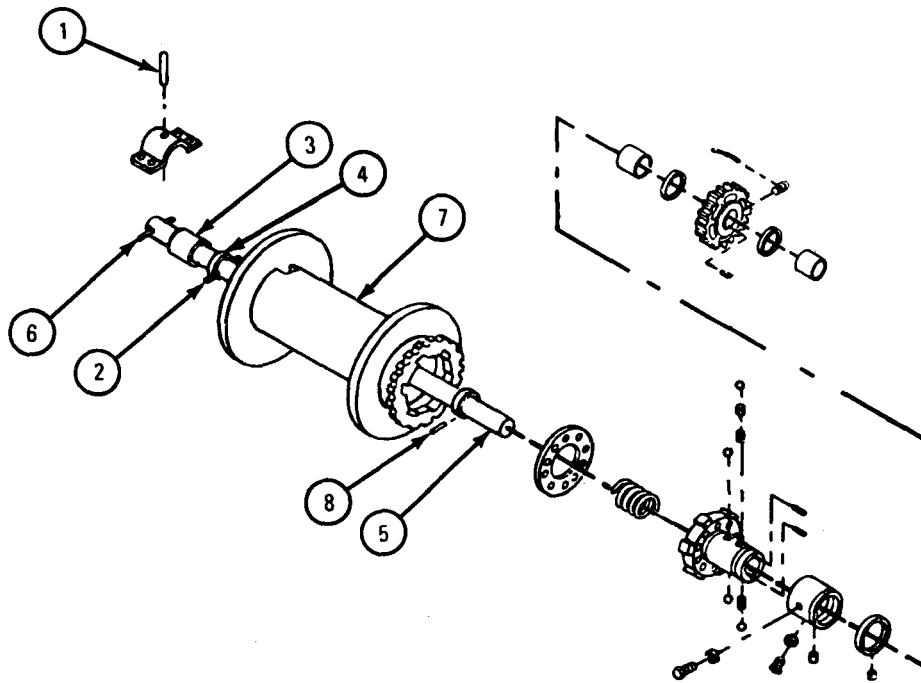

TA 089083

FRAME 15

1. Take out bushing (1) and thrust washer (2) from shaft (3).
2. Take off and throw away safety wire (4) from drive gear (5) and retaining setscrews (6).
3. Take off two setscrews (6) from drive gear (5).
4. Using a puller, pull drive gear (5) off shaft (3).
5. Take off two keys (7) from shaft (3).
6. Slide thrust washer (8) off shaft (3).
7. Slide bushing (9) off shaft (3).

GO TO FRAME 16

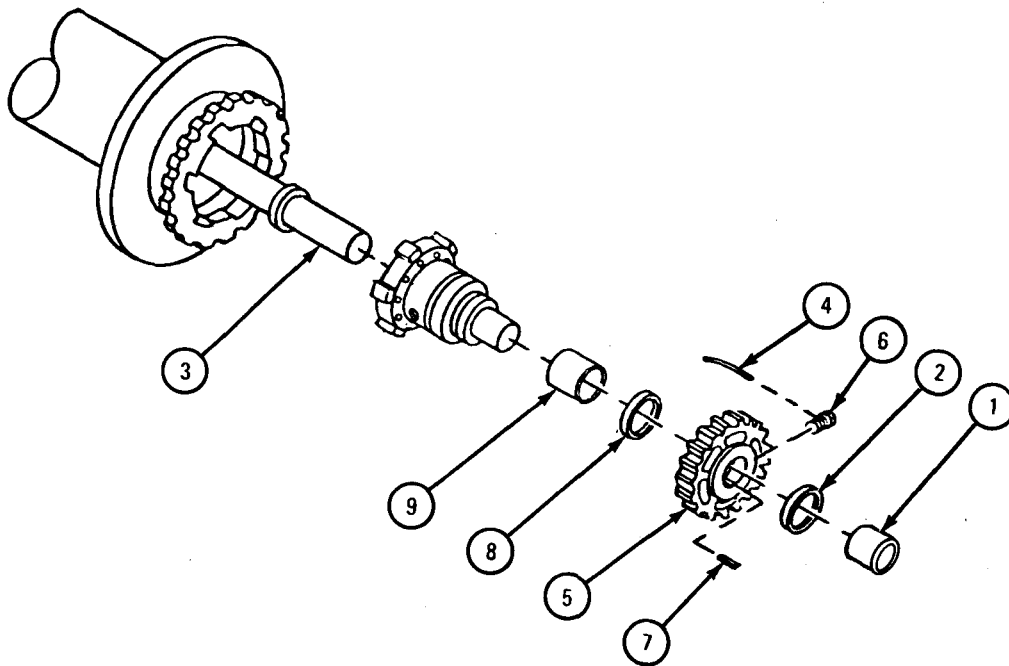

TA 089084

FRAME 16

1. Take out setscrew (1) with washer (2), pipe plug (3), and dog-point capscrew (4) from clutch spacer (5).

GO TO FRAME 17

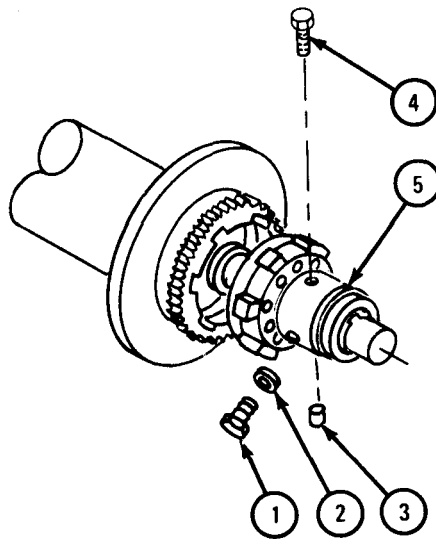

TA 105698

FRAME 17

1. Slide clutch spacer (1) toward step ring (2).

NOTE

Be sure not to lose ball, detent, and detent spring while turning clutch spacer.

2. Slowly turn clutch spacer (1) until ball (3) can be seen through untapped hole (4).
3. Take out ball (3) one detent (5), detent spring (6), and then the second detent from the untapped hole (4).
4. Turn clutch spacer (1) halfway around, and take out another ball (8) through untapped hole (4).

GO TO FRAME 18

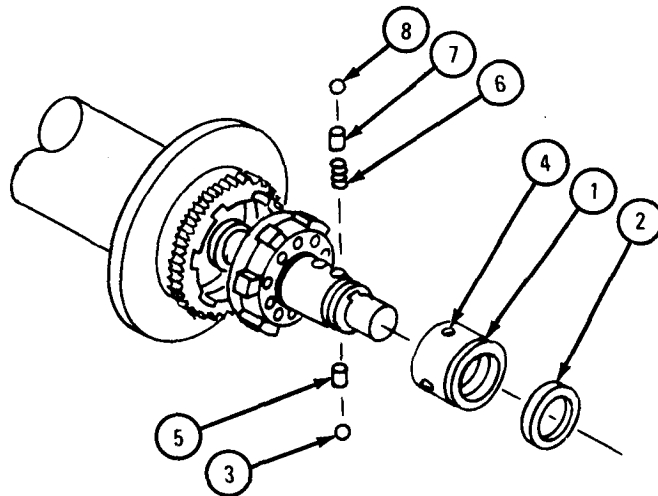

TA 089085

FRAME 18

1. Slide clutch spacer (1) toward gear part of brake plate assembly (2).
2. Turn clutch spacer (1), until ball (3) can be taken out of 9/16-inch diameter hole in sleeve.
3. Turn clutch spacer (1) halfway around, and take out ball (4).
4. Slide clutch spacer (1) and brake plate assembly (2) off shaft (5).
5. Take off two keys (6) from shaft (5).
6. Take out four rivets (7) holding stop ring (8) to brake plate assembly (2).
7. Take apart clutch spacer (1) and stop ring (8) from brake plate assembly (2).

NOTE

Do not take off brake lining (9) from brake plate assembly unless it is damaged. Refer to para 18-5e for inspection procedures.

8. Take out rivets to take apart lining from brake plate assembly.
9. Slide compression spring (10) off shaft (5).

GO TO FRAME 19

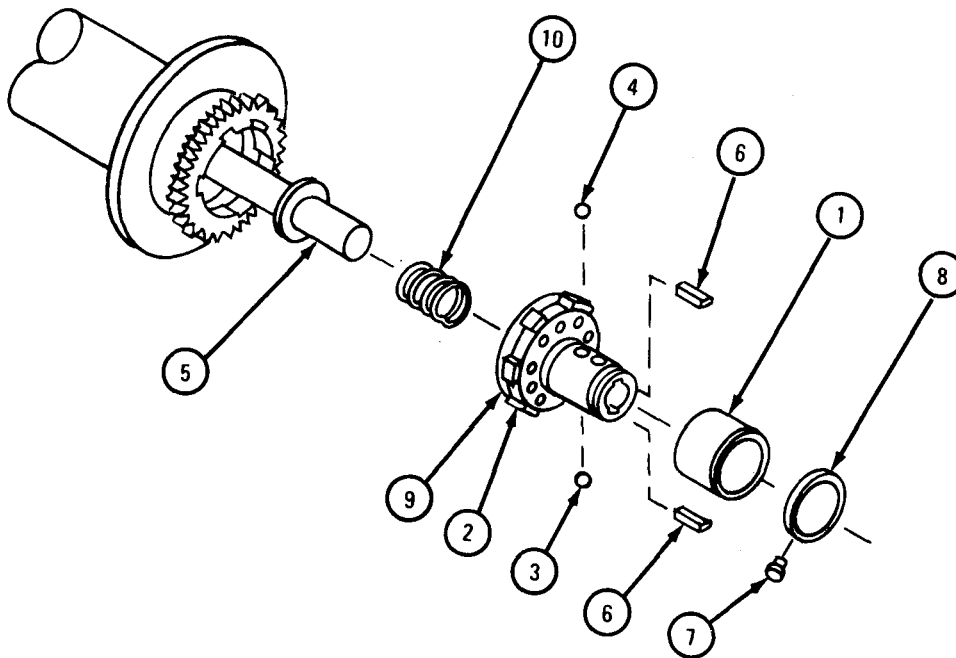

TA 089086

FRAME 19

1. Slide collar (1) off shaft (2).
2. Hold shaft (2) at pin end. Pull shaft out of drum (3).
3. Slide collar (4) and bushing (5) off shaft (2).

NOTE

Do not take out bearings (6 and 7) unless they are damaged. Refer to para 18-5e for inspection procedures.

4. Take out bearings (6 and 7).
5. Do not remove pin (8) from shaft (2), unless new drumshaft is being put in.

GO TO FRAME 20

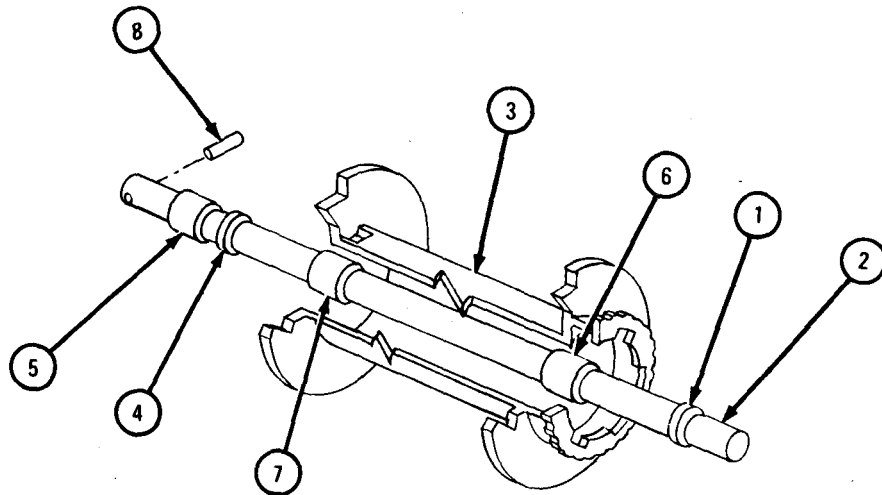

TA 089087

FRAME 20

1. Take out cotter pin (1) from adjusting bolt (2) and throw away cotter pin.

NOTE

Be sure not to lose thimbles (4) and springs (5) when bolts (2) are taken out of pressure plate (6).

2. Loosen nuts (3) on four adjusting bolts (2).
3. Take out bolts (2) with mating parts from bearing housing (7).
4. Take off pressure plate (6) with two thimbles (4) and springs (5).
5. Take off nuts (3) from adjusting bolts (2).
6. Take apart seats (8), springs (9), and washers (10) from adjusting bolts (2).

GO TO FRAME 21

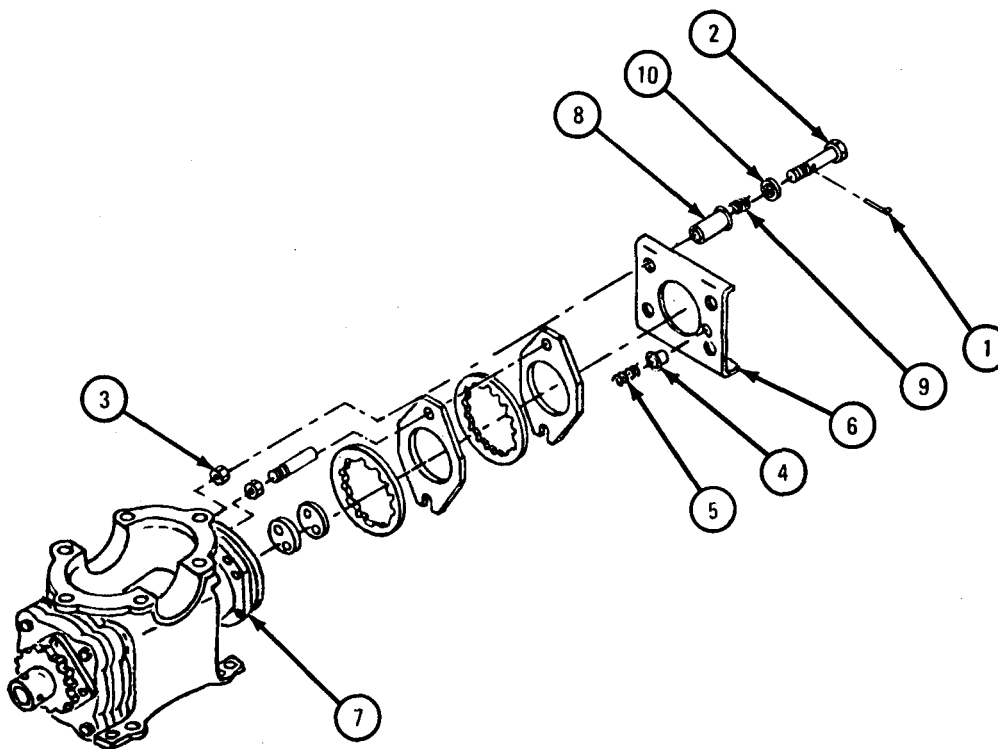

TA 089088

FRAME 21

1. Slide two lining plates (1) and two brake linings (2) from guide pins (3).
2. Loosen nuts (4) on guide pins (3). Take out guide pins. Take off nuts.
3. Take out two capscrews (5) and washers (6) that hold spacer plate (7) to worm brake (8).
4. Take off spacer plate (7) and gasket (9). Throw away gasket.
5. Pull stop pin (10) from worm brake (8).
6. Loosen worm brake (8) to take off brake from housing.

GO TO FRAME 22

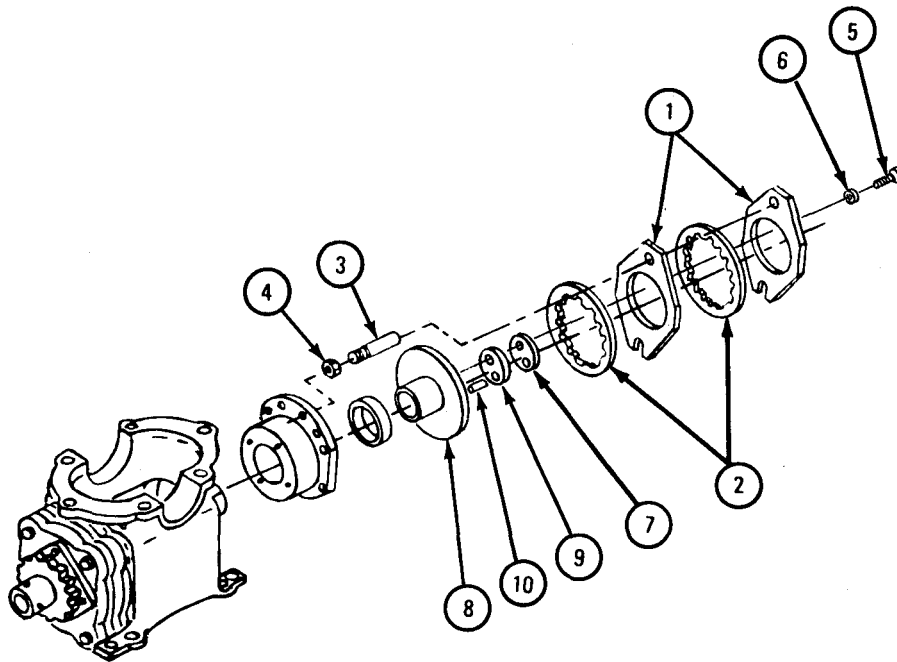

TA 089089

FRAME 22

1. Take off retaining ring (1) from sleeve (2).
2. Take out two cotter pins (3) from pin (4). Throw away cotter pins.
3. Pull pin (4) out of sprocket (5).
4. Pull sprocket (5) off sleeve (2).
5. Take off lubricating fitting (6) from sprocket (5).
6. Take out capscrew (7) and washer (8) that hold sleeve (2) to worm (9).
7. Take out sleeve (2) and key (10) from worm (9).

GO TO FRAME 23

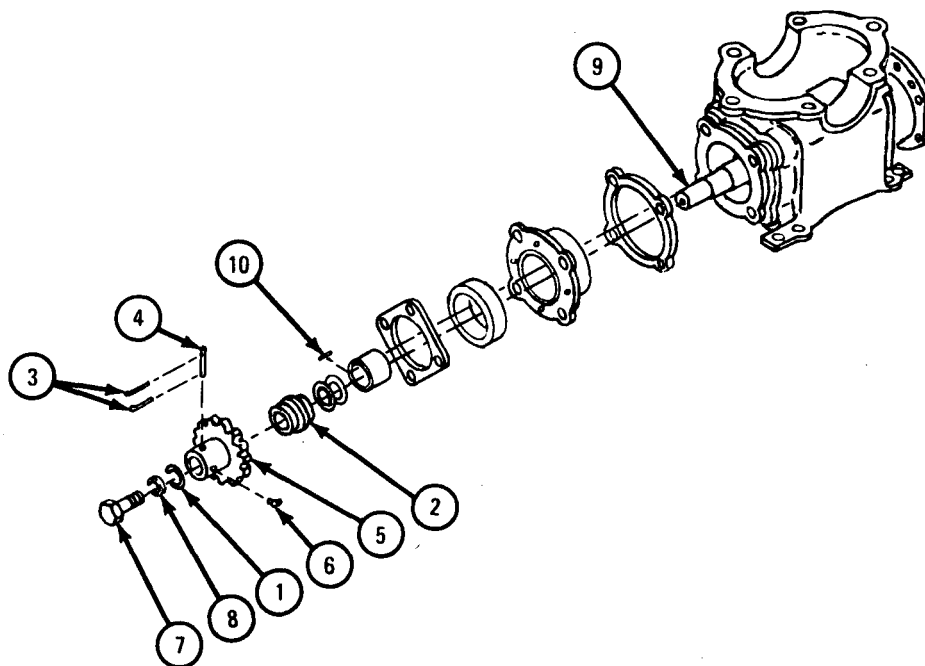

TA 089090

FRAME 23

1. Take out shim set (1) and spacer (2) from worm (3). Tie shim set together. Tag it.
2. Take out four screws and washers (4) from retaining plate (5).
3. Take off retaining plate (5).
4. Take off and throw away safety wire (6).
5. Take out capscrews (7) from retainer (8).
6. Take off retainer (8) with oil seal (9) and gasket (10). Throw away gasket.

NOTE

Do not take out oil seal (9) from retainer (8) unless it is damaged. Refer to para 18-5e for inspection procedures.

7. Take out oil seal (9) from retainer (8).

GO TO FRAME 24

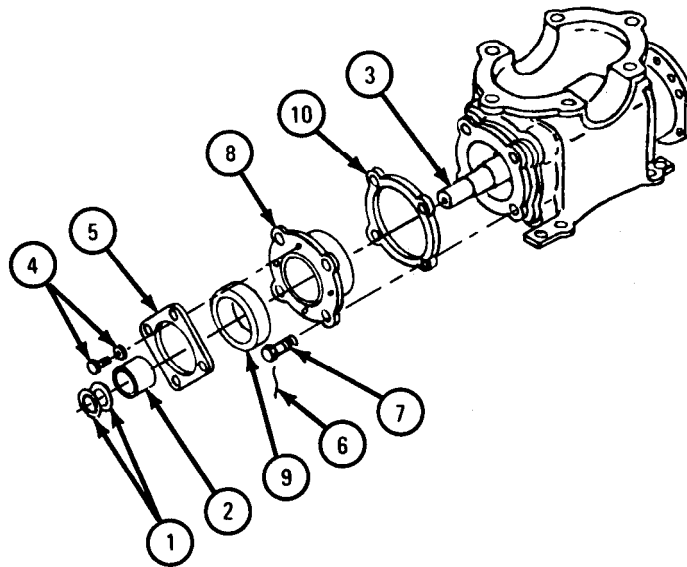

TA 089091

FRAME 24

1. Slide bearing housing (1) with inner and outer bearing cones (2 and 3) and gasket (4) off worm shaft (5). Throw away gasket.
 2. Take out two inner bearing cones (2) from housing (1).
 3. Take out shim set (6) and spacer (7). Tie shim set together. Tag it.
 4. Take out two outer bearing cones (3) from housing (1).
 5. Take out two pipe plugs (8) from worm housing (9).
- GO TO FRAME 25

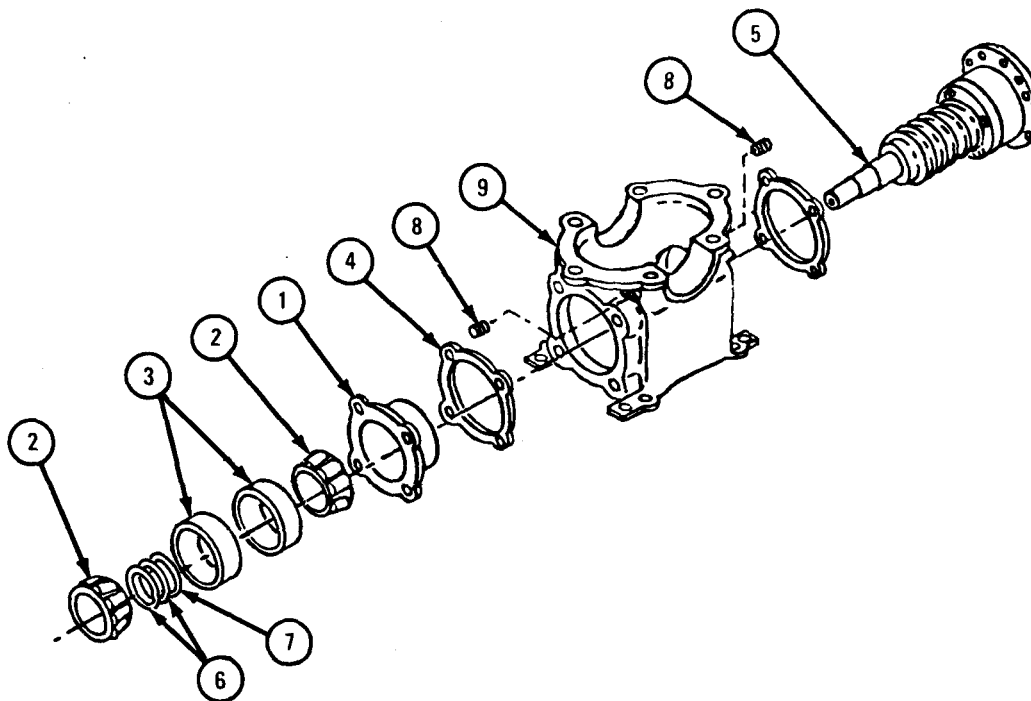

TA 089092

FRAME 25

1. Take off four capscrews (1) and washers (2) from bearing housing (3).
2. Lift off bearing housing (3) with mating parts from worm housing (4).
3. Take off gasket (5) from worm housing (4) and throw away gasket.
4. Take off safety wire (6) from bearing retainer mounting screws (7).
5. Take off capscrews (7) from retainer (8).
6. Take apart bearing housing (3) from retainer (8).
7. Check that roller bearing assembly (9) has no grooved, pitted or flattened rollers. If roller bearing assembly is damaged, take out roller bearing assembly (9) and oil seal (10). Refer to para 18-5e for inspection procedures.
8. If oil seal (10) shows signs of leakage or is burned, take out oil seal. Be sure not to damage bearing rollers. Refer to para 18-5e for inspection procedures.

GO TO FRAME 26

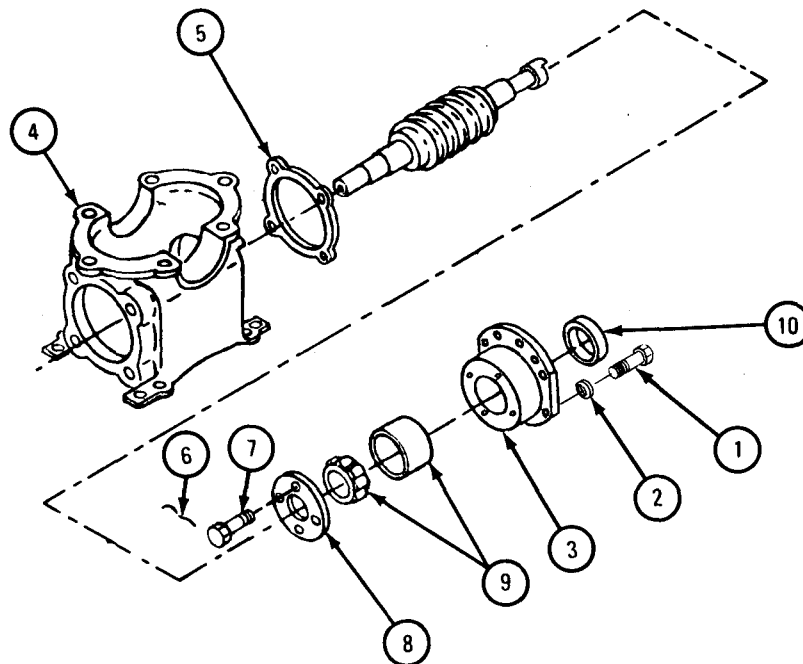

TA 089093

FRAME 26

1. Grind off flat end on retaining pin (1).
2. Drive pin (1) out of collar (2).
3. Take off collar (2) from stud (3).

NOTE

Do not take out stud (3) from end of worm shaft (4) unless threads are damaged. Refer to para 18-5e for inspection procedures.

4. Take out stud (3) from end of worm shaft (4).

END OF TASK

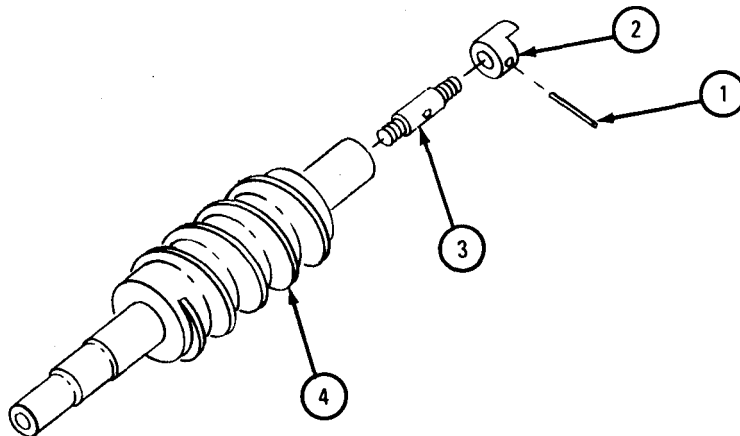

TA 089094

d. Cleaning. There are no special cleaning procedures required. Refer to cleaning procedures given in Part 1, para 1-3.

e. Inspection and Repair.

FRAME 1

1. Check that idler pulley shaft (1) is not nicked, cracked, galled, scored or has no damaged threads. If idler pulley shaft (1) is damaged, get a new one.
2. Put clean lubricating oil ICE, OE/HDO 10, MIL-L-2104 on two bearings (2) and turn by hand. The bearing must turn without binding. If bearing assemblies are damaged, put in new ones.
3. Check that two bearing cups (3) are not scored or pitted. If bearing cups are damaged, get new ones.
4. Check that bearing seals (4 and 5) are not worn, torn or burned. Be sure seal makes good seal contact with pulley (6). If bearing seals are damaged, get new ones.

GO TO FRAME 2

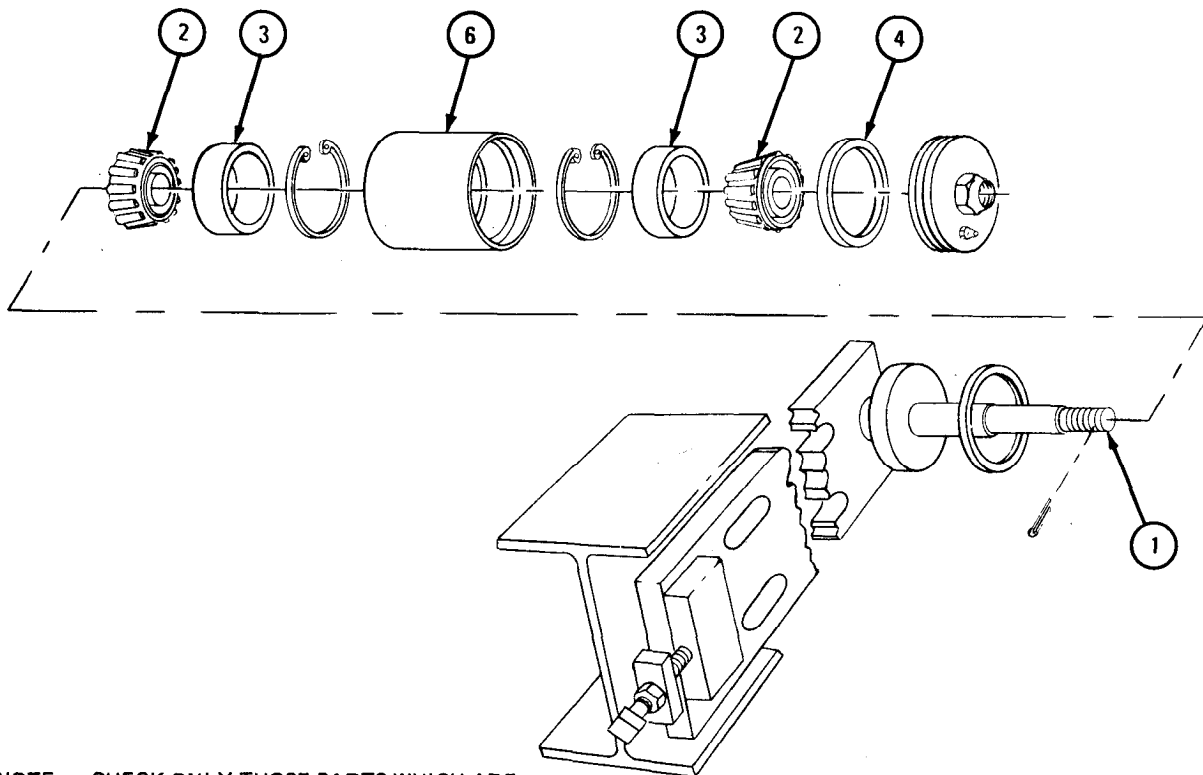

NOTE: CHECK ONLY THOSE PARTS WHICH ARE CALLED OUT IN THIS FRAME. PARTS WITHOUT CALLOUTS ARE SHOWN ONLY FOR REFERENCE PURPOSES OR ARE CHECKED IN ANOTHER FRAME.

TA 089095

FRAME 2

1. Check that sprockets (1 through 3) have no chipped or broken teeth. If sprockets have chipped or broken teeth, get new ones.
2. Check that sprocket shafts (4 through 6) have no cracks. If sprocket shafts are cracked, get new ones.
3. Check that sprocket shafts (4 through 6) are not bent, nicked, scratched, or burred. Smooth out raised metal, nicks, or scratches with a honing stone and polish with a crocus cloth.
4. Check that bearings (7 through 9) are not pitted, burred, grooved, or rough. Polish small damage with crocus cloth.
5. Check that bearings (7 through 9) are not cracked. If bearings are damaged, get new ones.

GO TO FRAME 3

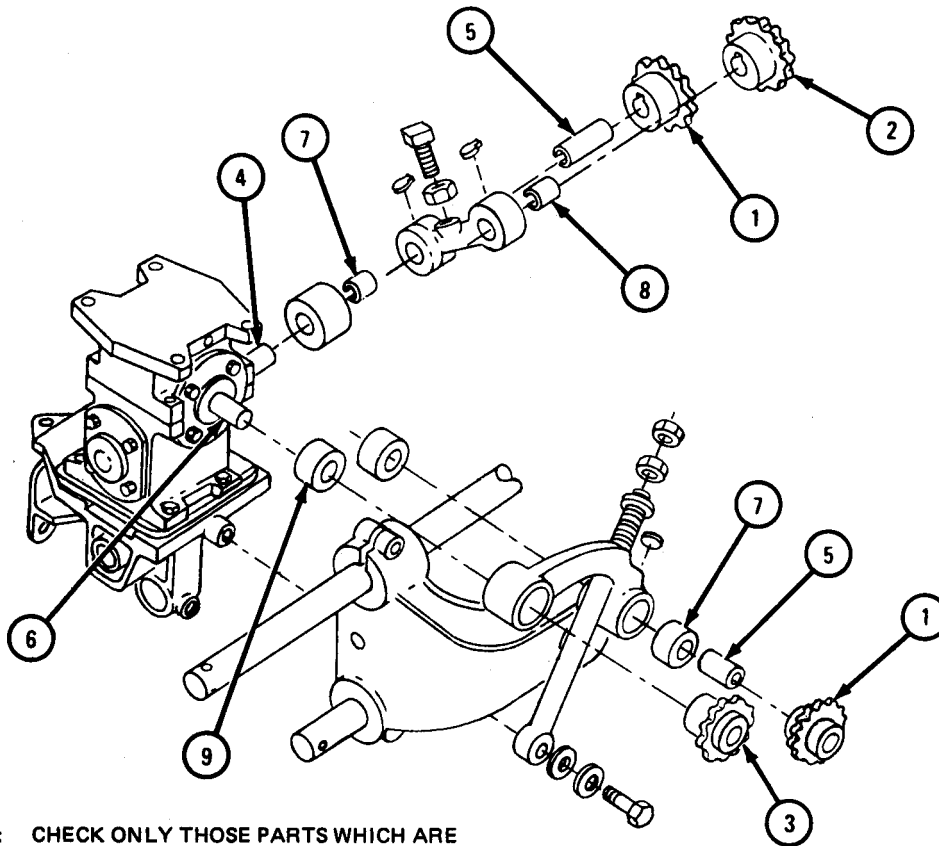

NOTE: CHECK ONLY THOSE PARTS WHICH ARE CALLED OUT IN THIS FRAME. PARTS WITHOUT CALLOUTS ARE SHOWN ONLY FOR REFERENCE PURPOSES OR ARE CHECKED IN ANOTHER FRAME.

TA 089096

FRAME 3

NOTE

Readings must be within limits given in table 18-7.
The letter L indicates a loose fit. If readings are not within given limits throw away part and get a new one.

1. Measure outside diameter of speed reducer input shaft (1).
2. Measure inside diameter of sprocket shaft bearing (2).
3. Measure fit of bearing (2) on speed reducer input shaft (1).
4. Measure inside diameter of sprocket shaft bracket bearing (3).
5. Measure outside diameter of idler sprocket shaft (4).
6. Measure fit of bearing (3) on idler shaft (4).

GO TO FRAME 4

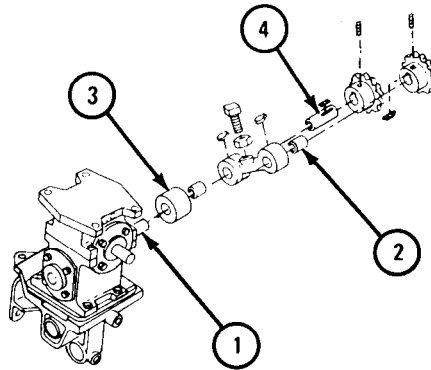

TA089097

Table 18-7. Rear Winch (First Reduction Drive Assembly)Wear Limits

Index Number	Item/Point of Measurement	Size and Fit of New Parts (inches)	Wear Limit (inches)
1	Outside diameter of speed reducer input shaft	0.749 to 0.750	None
1 and 2	Fit of bearing on speed reducer input shaft	0.001L to 0.004L	None
2	Inside diameter of sprocket shaft bracket bushing-type bearing	0.752 to 0.753	0.762 to 0.763
3	Inside diameter of sprocket shaft bracket bushing-type bearing	0.875 to 0.876	0.885 to 0.886
3 and 4	Fit of bearing on idler shaft	0.001L to 0.005L	None
4	Inside diameter of sprocket shaft bracket bushing-type bearing	0.752 to 0.753	0.762 to 0.763

FRAME 4

NOTE

Readings must be within limits given in table 18-8.
 The letter L indicates a loose fit. If readings are not within given limits, throw away part and get a new one.

- Measure outside diameter of idler sprocket shaft (1).
 - Measure inside diameter of sprocket bearing (2).
 - Measure fit of bearing (2) on idler sprocket shaft (1).
 - Measure inside diameter of sprocket bearing (3).
 - Measure outside diameter of output shaft (4).
 - Measure fit of bearing (3) on output shaft (4).
- GO TO FRAME 5

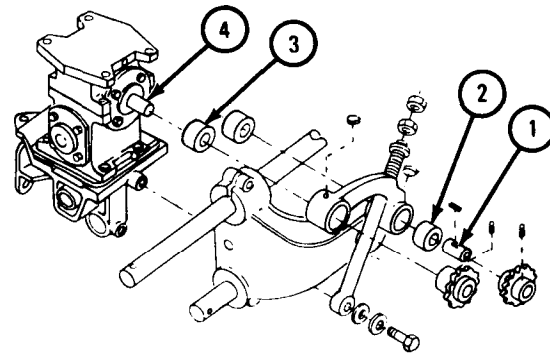

NOTE: CHECK ONLY THOSE PARTS WHICH ARE CALLED OUT IN THIS FRAME. PARTS WITHOUT CALLOUTS ARE SHOWN ONLY FOR REFERENCE PURPOSES OR ARE CHECKED IN ANOTHER FRAME.

TA 089098

Table 18-8. Rear Winch(Second Reduction Drive Assembly)Wear Limits

Index Number	Item/Point of Measurement	Size and Fit of New Parts (inches)	Wear Limit (inches)
1	Outside diameter of idler sprocket shaft	0.873 to 0.875	0.863 to 0.865
1 and 2	Fit of bearing on idler shaft	0.001L to 0.005L	None
2	Inside diameter of sprocket shaft bracket bushing-type bearing	0.875 to 0.876	0.886 to 0.888
3	Inside diameter of sprocket bushing-type bearing	1.000 to 1.001	1.001 to 1.010
3 and 4	Fit of bearing on speed reducer output shaft	0.001L to 0.004L	None
4	Outside diameter of speed reducer output shaft	0.099 to 1.000	None

FRAME 5

1. Check that two sprockets (1) and sprocket (2) are not chipped or have broken teeth. If sprockets are damaged, get new ones.
2. Check that shaft portions of sprockets (1 and 2) are not distorted, burred, nicked or scratched. Smooth out raised metal, nicks, or scratches with a honing stone and polish with a crocus cloth.
3. Check that tie rods (3) and horns (4) are not cracked. If shafts are damaged, get new ones.
4. Check that tie rods (3) and horns (4) are not bent, burred, nicked, or scratched. If shafts are damaged, get new ones. Smooth out raised metal, nicks, or scratches with a honing stone and polish with a crocus cloth.
5. Check that bearings (5, 6, and 7) are not pitted, burred) grooved, or rough. Polish small damage with a crocus cloth.
6. Check that bearings (5, 6, and 7) are not cracked. If bearings are cracked, get new ones.
7. Check that cross chain (8) is not damaged or has broken links. If cross chain is damaged or has broken links, get new links or chain assembly.
8. Check that guide pin (9) has no flat areas on wear plate portion of pin. Turn guide pin in chain guide if damage is small. If guide pin is damaged in any other way, get new one.
9. Check that wear plates (10) do not have uneven wear spots. If wear plates are damaged, get new ones.

GO TO FRAME 6

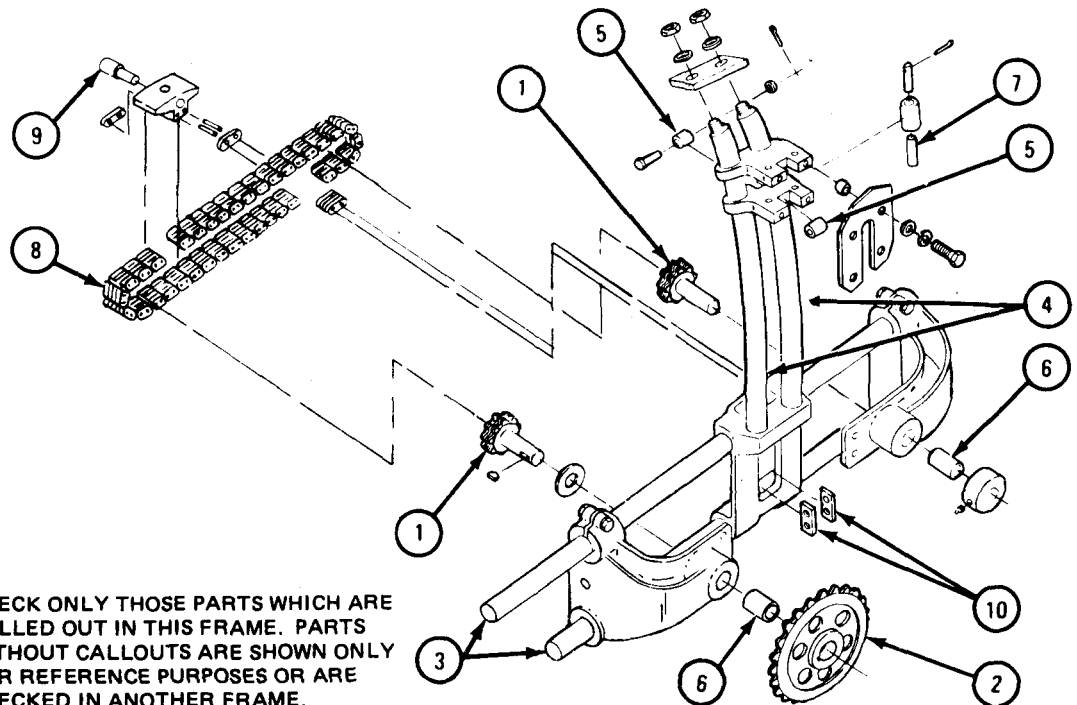

NOTE: CHECK ONLY THOSE PARTS WHICH ARE CALLED OUT IN THIS FRAME. PARTS WITHOUT CALLOUTS ARE SHOWN ONLY FOR REFERENCE PURPOSES OR ARE CHECKED IN ANOTHER FRAME.

TA 089099

FRAME 6

NOTE

Readings must be within limits given in table 18-9. The letter L indicates a loose fit. If readings are not within given limits, throw away part and get a new one.

Measure the outside diameter of vertical roller shaft (1).

Measure the inside diameter of bearing (2).

Measure the fit between vertical roller shaft (1) and bearing (2).

Measure the outside diameter of sprocket shafts (3 and 5).

Measure the inside diameter of bearings (4 and 6).

Measure the fit between bearings (4 and 6) and sprocket shafts (3 and 5).

GO TO FRAME 7

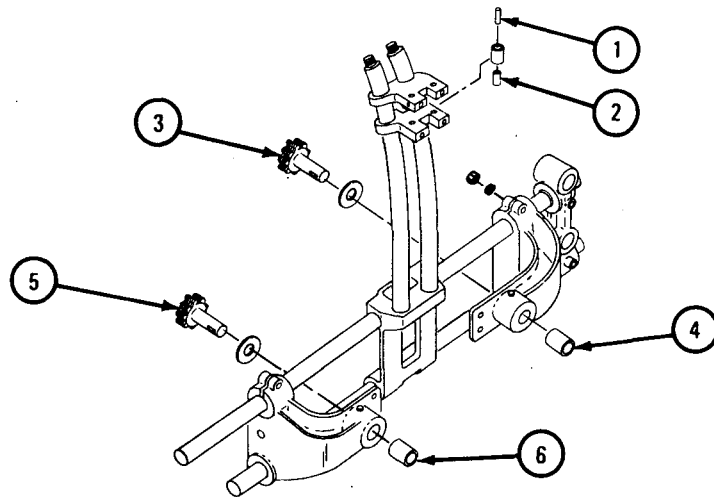

CHECK ONLY THOSE PARTS WHICH ARE CALLED OUT IN THIS FRAME. PARTS WITHOUT CALLOUTS ARE SHOWN ONLY FOR REFERENCE PURPOSES OR ARE CHECKED IN ANOTHER FRAME.

TA 089100

Table 18-9. Rear Winch(Cable Level Winder Assembly)Wear Limits

Index Number	Item/Point of Measurement	Size and Fit of New Parts (inches)	Wear Limit (inches)
1	Outside diameter of vertical roller shaft	0.495 to 0.499	0.485 to 0.489
1 and 2	Fit of bearing on shaft	0.003L to 0.007L	None
2	Inside diameter of vertical roller bushing-type bearing	0.502 to 0.512	0.512
3	Outside diameter of cross-chain sprocket shaft	1.245 to 1.247	1.235 to 1.237
3 and 4	Fit of bearing on sprocket shaft	0.003L to 0.007L	None
4	Inside diameter of cross chain bracket bushing-type bearing	1.250 to 1.252	1.260 to 1.262
5	Outside diameter of cross chain sprocket shaft	1.245 to 1.247	1.235 to 1.237
5 and 6	Fit of bearing on sprocket shaft	0.003L to 0.007L	None
6	Inside diameter of cross chain bracket bushing-type bearing	1.250 to 1.252	1.260 to 1.262

FRAME 7

1. Check that gear (1) has no sharp fins or burrs at tooth corners. Smooth out small damage with a honing stone. If gear is damaged in any other way, get a new one.
2. Check that gear (1) is not cracked. If gear is cracked, get a new one.
3. Check that gear (1) is not chipped or has broken teeth. If any teeth are damaged, get a new gear.
4. Check that clutch teeth on clutch and brake plate (2) are not worn or damaged. Smooth out small damage to clutch teeth with a honing stone.
5. Check that bearings (3 through 6) are not pitted, burred, grooved or rough. Polish small damage with crocus cloth.
6. Check that bearings (3 through 6) are not cracked. If bearings are cracked, get new ones.

GO TO FRAME 8

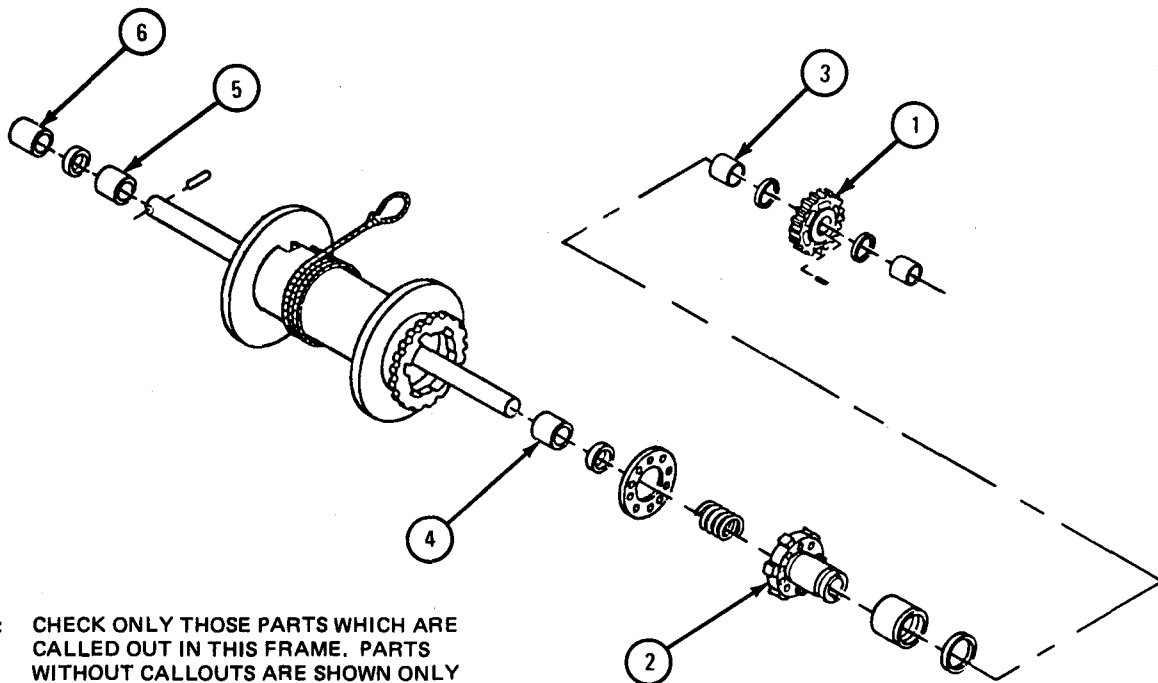

NOTE: CHECK ONLY THOSE PARTS WHICH ARE CALLED OUT IN THIS FRAME. PARTS WITHOUT CALLOUTS ARE SHOWN ONLY FOR REFERENCE PURPOSES OR ARE CHECKED IN ANOTHER FRAME.

TA 101006

FRAME 8

1. Check that clutch detent sleeve (1) is not cracked. If clutch detent sleeve is cracked, get a new one.
2. Check that clutch detent sleeve (1) has no outer damage. If clutch detent sleeve has outer damage, get a new one.
3. Check inner diameter of clutch detent sleeve for deep lengthwise grooving caused by the action of balls (2 and 3).
4. If two sets of wear grooves are present, take out capscrew (4) and washer (5) in their present location and install in hole formerly occupied by screw (6) and washer (7).
5. If four sets of wear grooves are present, then capscrew (4) and washer (5) have previously been moved. Put in new clutch detent sleeve (1). Put capscrew (4) and washer (5) back into their original position on new sleeve.

GO TO FRAME 9

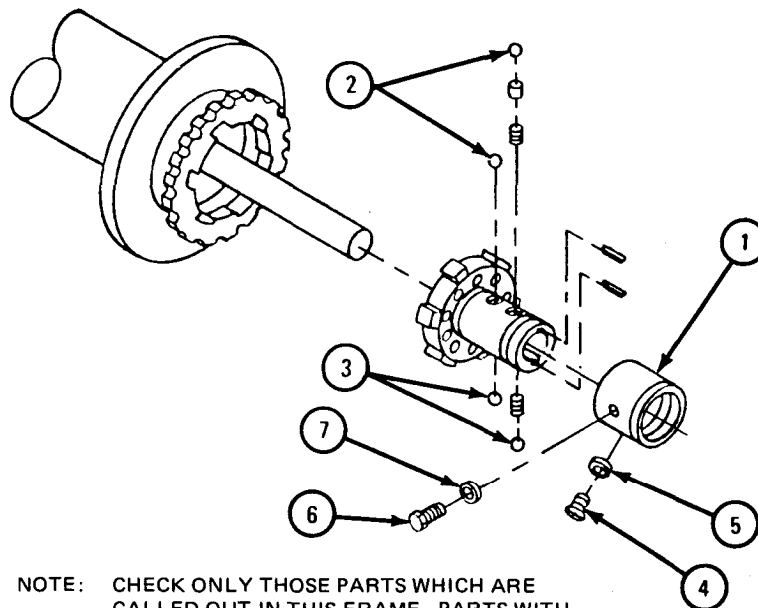

NOTE: CHECK ONLY THOSE PARTS WHICH ARE CALLED OUT IN THIS FRAME. PARTS WITHOUT CALLOUTS ARE SHOWN ONLY FOR REFERENCE PURPOSES OR ARE CHECKED IN ANOTHER FRAME.

TA 101007

FRAME 9

NOTE

Readings must be within limits given in table 18-10. The letter L points out a loose fit. If readings are not within given limits, throw away part and get a new one.

1. Measure inside diameter of bearings (1, 3, and 4).
2. Measure outside diameter of drumshaft (2).
3. Measure fit between bearings (1, 3, and 4) with drumshaft (2).
4. Measure the thickness of drumshaft retaining collar (5).
5. Measure the thickness of drum brake lining (6).
6. Measure the thickness of drive gear thrust washers (7).

GO TO FRAME 10

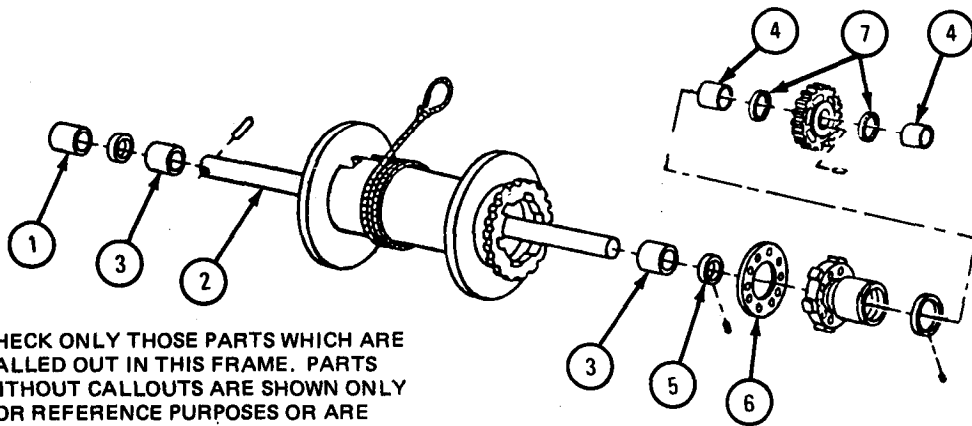

NOTE: CHECK ONLY THOSE PARTS WHICH ARE CALLED OUT IN THIS FRAME. PARTS WITHOUT CALLOUTS ARE SHOWN ONLY FOR REFERENCE PURPOSES OR ARE CHECKED IN ANOTHER FRAME.

TA 101008

Table 18-10. Rear Winch(Drum and Shaft)Wear Limits

Index Number	Item/Point of Measurement	Size and Fit of New Parts (inches)	Wear Limit (inches)
1	Inside diameter of drumshaft-to-support bushing-type bearing	2.446 to 2.448	2.456 to 2.468
2	Outside diameter of drumshaft	2.433 to 2.438	2.423 to 2.428
1 and 2	Fit of bearing on shaft	2.446 to 2.448	2.456 to 2.458
3	Inside diameter of drum bushing-type bearings	2.446 to 2.448	2.456 to 2.458
2 and 3	Fit of bearing on shaft	0.008L to 0.015L	None
4	Inside diameter of drumshaft-to-worm gear housing bushing-type bearing	2.446 to 2.448	2.456 to 2.458
2 and 4	Fit of bearing on shaft	0.008L to 0.155L	None
5	Thickness of drumshaft retaining collar	0.864 to 0.884	0.839 to 0.859
6	Thickness of drum brake lining	0.375	0.313
7	Thickness of drive gear thrust washer	0.217 to 0.220	0.212 to 0.220

FRAME 10

1. Check that worm (1) and sprocket (2) have no sharp fins or burrs at tooth corners. If worm and sprocket are damaged, get new ones. Smooth out small damage with a honing stone.

NOTE

If new worm (1) is being put in, you must order worm assembly, consisting of worm (1), collar (3), and stud (4).

2. Check that worm (1) and sprocket (2) is not cracked. If worm (1) and sprocket (2) are cracked, get new ones.
3. Check that worm (1) and sprocket (2) have no chipped or broken teeth. If any teeth are damaged, get new worm and sprocket.
4. Put clean oil ICE, OE/HDO 10, MIL-L-2104 on each bearing (5 and 6) and turn slowly by hand. The bearing must turn without binding. If bearing assemblies are worn or damaged, get new ones.
5. Check that bearing rollers (5) are not grooved, pitted, or flattened. If bearing rollers are worn or damaged, get new ones.
6. Check that bearing cups (6) are not scored and pitted. If bearing cups are damaged, get new ones.

GO TO FRAME 11

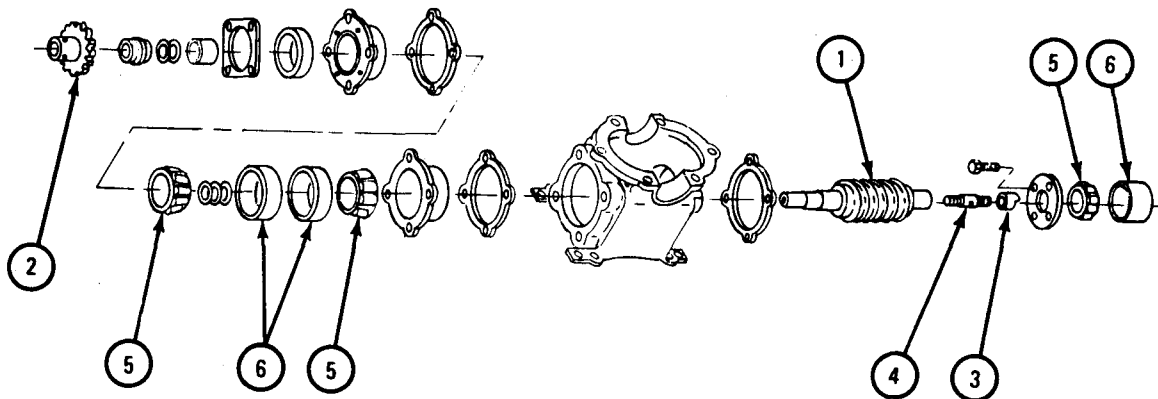

NOTE: CHECK ONLY THOSE PARTS WHICH ARE CALLED OUT IN THIS FRAME. PARTS WITHOUT CALLOUTS ARE SHOWN ONLY FOR REFERENCE PURPOSES OR ARE CHECKED IN ANOTHER FRAME.

TA 101009

FRAME 11

1. Check that oil seals (1 and 2) are pliable and show no signs of burning. If any seal is not pliable or shows signs of burning, get new one.
2. Check that feather edge of oil seals (1 and 2) is not damaged and is in proper contact with turning parts.
3. If there was oil leakage before disassembly, put in new oil seals (1 and 2).
4. Check spacer (3) and worm brake (4) for grooving caused by damaged oil seals (1 or 2). If spacer and worm brake are grooved, get new ones.

GO TO FRAME 12

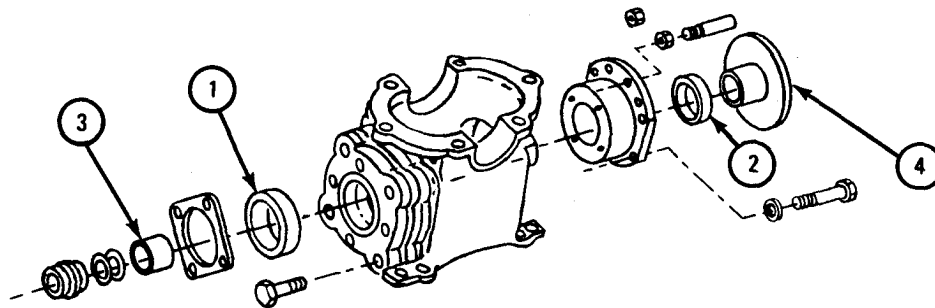

NOTE: CHECK ONLY THOSE PARTS WHICH ARE CALLED OUT IN THIS FRAME. PARTS WITHOUT CALLOUTS ARE SHOWN ONLY FOR REFERENCE PURPOSES OR ARE CHECKED IN ANOTHER FRAME.

TA 101010

FRAME 12

NOTE

Readings must be within limits given in table 18-11.
 If readings are not within given limits, throw away part and get a new one.

1. Measure the outside diameter of automatic stop pin (1).
2. Measure the thickness of automatic brake lining (2).
3. Measure the thickness of automatic brake lining plate (3).

END OF TASK

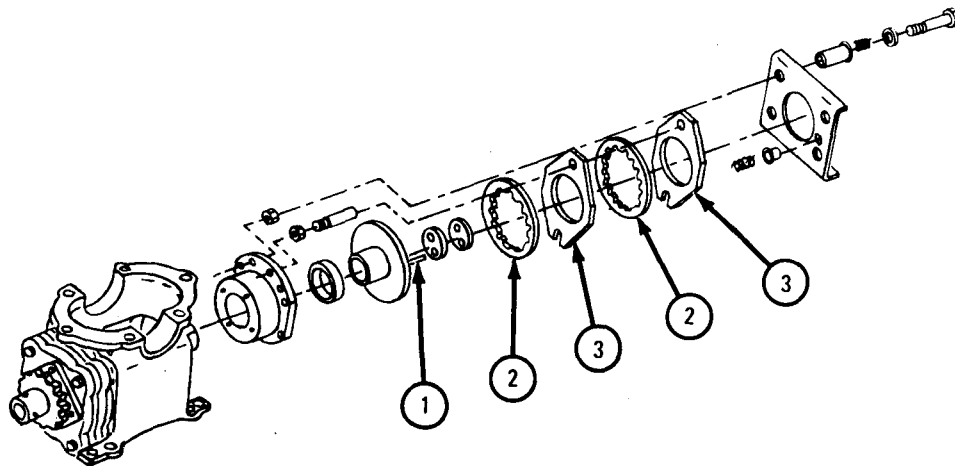

NOTE: CHECK ONLY THOSE PARTS WHICH ARE CALLED OUT IN THIS FRAME. PARTS WITHOUT CALLOUTS ARE SHOWN ONLY FOR REFERENCE PURPOSES OR ARE CHECKED IN ANOTHER FRAME.

TA 101011

Table 18-11. Rear Winch(Automatic Brake Assembly)Wear Limits

Index Number	Item/Point of Measurement	Size and Fit of New Parts (inches)	Wear Limit (inches)
1	Outside diameter of worm automatic stop pin	0.436 to 0.437	0.431 to 0.432
2	Thickness of worm automatic brake lining	0.125	0.084
3	Thickness of worm automatic brake lining plate	0.094 to 0.125	0.084 to 0.45

f. Assembly.

FRAME 1

1. If bearing (1) was taken out, pack new bearing with type GAA grease, MIL-G-10924.
2. Press bearing (1) into housing (2).
3. Place retainer (3) on housing (2). Put on four capscrews (4).
4. Tie capscrews (4) together with safety wire (5).
5. If oil seal (6) was taken out, press new seal into housing (2). Be sure that seal lip faces inside of bearing housing.
6. Place nut (7) on pin (8).
7. Put pin (8) onto housing (2) and tighten with nut (7).

GO TO FRAME 2

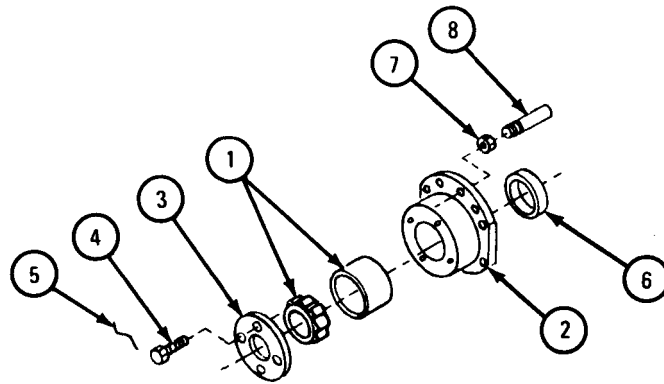

TA 101012

FRAME 2

1. If new worm brake stud (1) is put on worm (2), the new stud will not have a drilled hole for retaining pin (3).
2. Put new worm brake stud (1) on worm (2) with flat on stud, facing the outside.
3. Put hole on worm brake stud (1) 1 1/8 inches from end of worm (2).
4. Drill a 3/8-inch diameter hole into worm brake stud (1). Ream to 0.375 to 0.376-inch diameter.
5. If new brakeshaft collar (4) is put on worm brake stud (1), drill new collar on one side only.
6. Put new brakeshaft collar (4) on worm brake stud (1). Aline hole in collar with hole in stud.
7. Using hole in stud and collar as a guide, drill a 3/8-inch diameter hole through blank side of brakeshaft collar (4). Ream collar to 0.375 to 0.376-inch diameter. Countersink both sides of collar 1/16-inch deep by 80° to 100°.
8. Put brakeshaft collar (4) on worm brake stud (1) and put in retaining pin (3).
9. Flare each end of retaining pin (3) on brakeshaft collar (4).
10. File or grind each end of retaining pin (3) flush with outer surface of brakeshaft collar (4).

GO TO FRAME 3

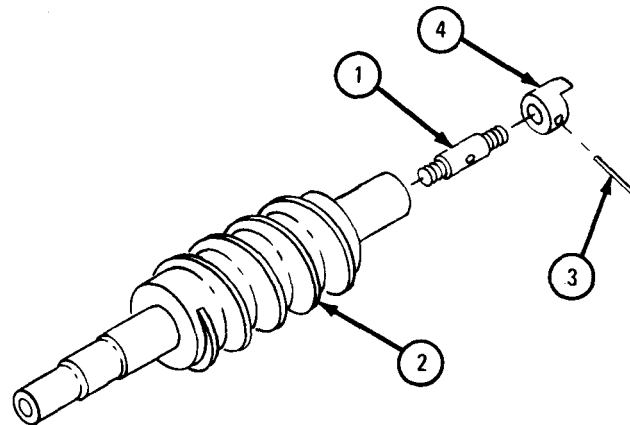

TA 101013

FRAME 3

CAUTION

Wrap worm (1) in cloth before placing in vise, to protect worm from damage by vise jaws.

1. Put worm (1) in a vertical position in a vise, with sprocket end of wormshaft facing upward.
2. Put first bearing assembly (2) on shaft of worm (1).
3. Put washer (3) and shim set (4) on shaft of worm (1).
4. Put second bearing assembly (2) on shaft of worm (1).
5. Put spacer (5), shim set (6), key (7), and sleeve (8) on shaft of worm. Put on capscrew and washer (9).
6. Put two 0.005-inch feeler gages (10) (180° apart) between cups of first and second bearing assemblies (2). Check for 0.005 to 0.007-inch clearance between cups.

NOTE

Be sure that both bearing cups are properly seated against bearings when checking clearance.

7. If needed, take off parts from wormshaft and fix bearing shim set (4) by adding or taking out shims for proper bearing cup clearance.
8. Take off parts (2 through 9) from worm (1). Take out worm (1) from vise.

GO TO FRAME 4

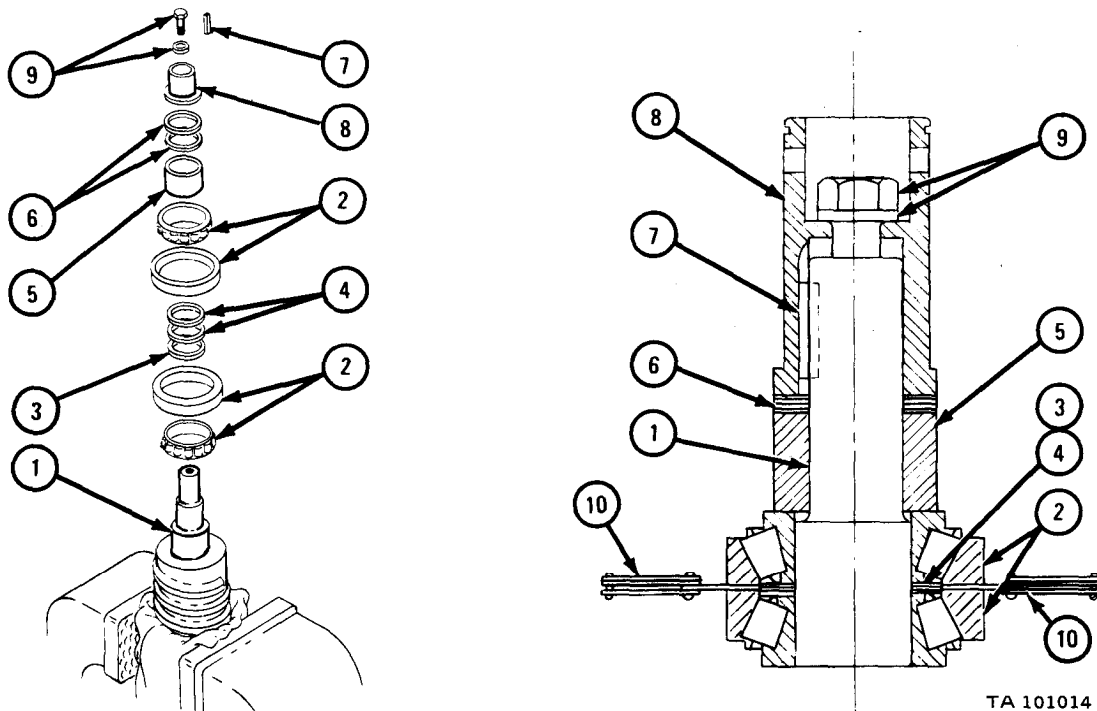

TA 101014

FRAME 4

1. Put plugs (1) on housing (2).
2. Put new gasket (3) on housing (2).
3. Put worm roller bearing housing (4) in housing (2).
4. Put on four capscrews (5) and washers (6).
5. Put worm assembly (7) in housing (2) with sprocket end facing out. Guide brake step end of wormshaft through bearing housing (4).
6. Put bearing housing (8) and new gasket (9) on housing (2).

GO TO FRAME 5

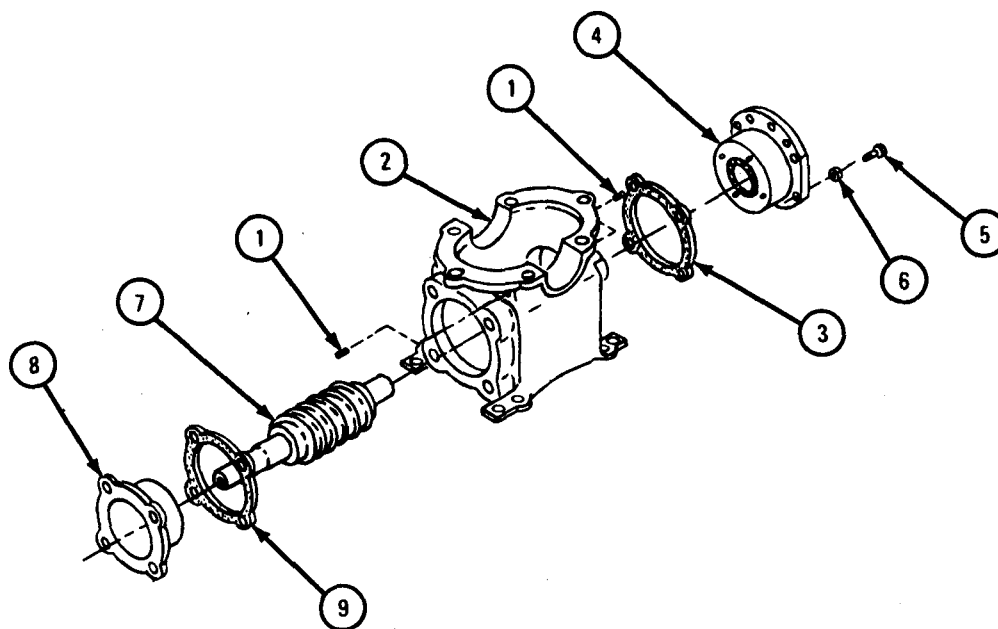

TA 101015

FRAME 5

1. Pack thrust bearings (1 and 2) with **type GAA** lubricating grease, MIL-G-10924.
2. Put bearing assembly (1) on wormshaft (3).
3. Put washer (4) and shim set (5) on worm shaft (3).

NOTE

Be sure to use shim set which was fixed for proper clearance in frame 3.

4. Put bearing assembly (2) on wormshaft (3).
5. If oil seal (6) was taken off bearing retainer (7), press new seal into retainer with lip of seal facing inside of retainer.
6. Put retaining plate (8) on bearing retainer (7).
7. Put on four capscrews (9) and washers (10).

GO TO FRAME 6

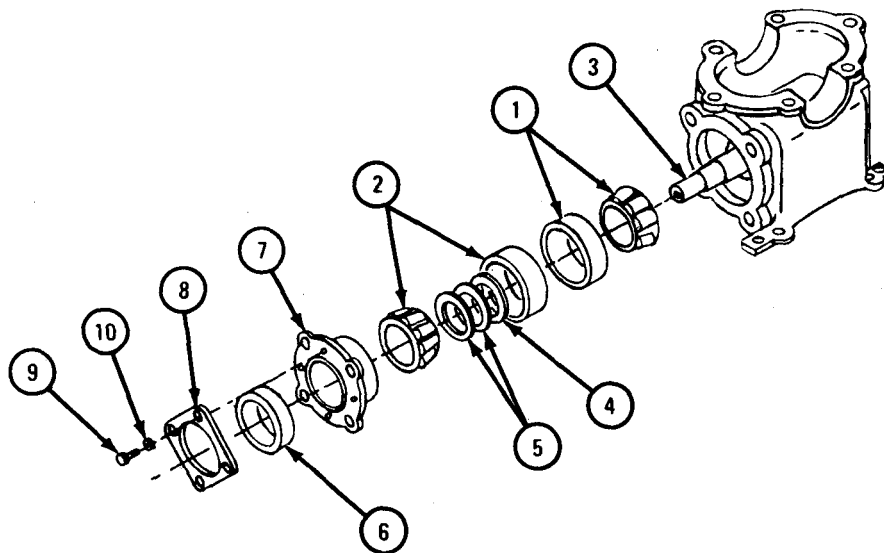

TA 101016

FRAME 6

1. Put new gasket (1) and bearing retainer (2) on bearing housing (3).
2. Put two capscrews (4) on the lower part of bearing housing (3) and bearing retainer (2).

NOTE

The upper capscrews are put in during installation of cable level winder assembly.

3. Tie capscrews (4) together with safety wire (5).
4. Put spacer (6) on wormshaft (7) up against outer bearing assembly (8).
5. Be sure that oil seal (9) is properly seated around spacer (6).

GO TO FRAME 7

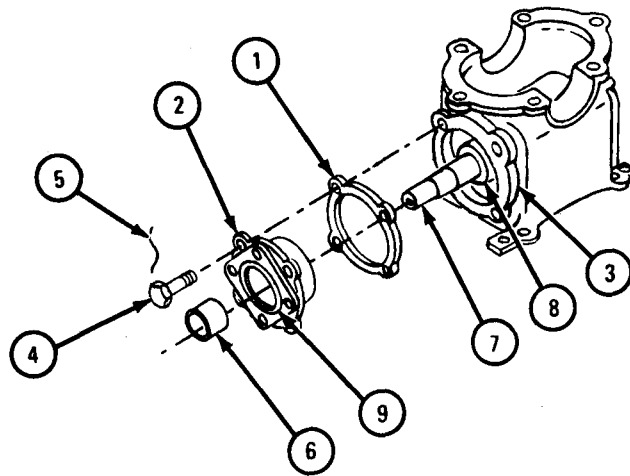

TA 101017

FRAME 7

1. Put the original shim set (1) on wormshaft (2).
2. Put key (3) on wormshaft (2) and slide sleeve (4) over key.
3. Put on capscrew and washer (5).
4. Turn wormshaft (2) to be sure inner bearing cone is properly seated against shoulder of wormshaft.
5. Slide sprocket (6) over sleeve (4). Aline hole in sprocket with hole in sleeve.
6. Put pin (7) through sprocket (6) and sleeve (4).
7. Put on two cotter pins (8).
8. Put lubricating fitting (9) on sprocket (6).
9. Put retaining ring (10) on sleeve (4).

GO TO FRAME 8

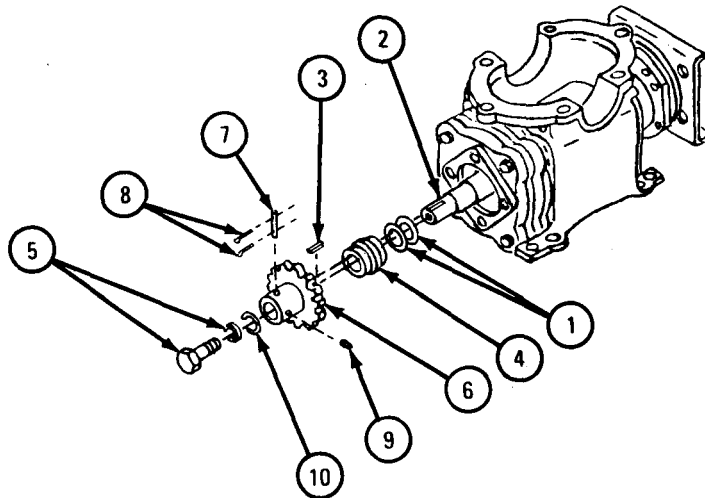

TA 101018

FRAME 8

1. Turn sprocket (2) until stop lug on brake collar (1) is on top.

NOTE

During the following procedure, the location of the stop lug on brake collar (1) must be known at all times.

2. Press hard on sprocket (2), forcing worm (3) to move as far forward as possible.
3. With stop lug on brake collar (1) on top, thread worm brake (4) onto stud end of worm (3) until the outer face of brake is $3 \frac{1}{32}$ inches from the inner face of bearing housing (5).
4. Put tapered end of stop pin (6) into the nearest hole to the left of stop lug on brake collar (1). Tap pin until end of pin is slightly below surface of worm brake (4).
5. Put new gasket (7) and retaining plate (8) on worm brake (4).
6. Put two capscrews (9) and washers (10) on retaining plate (8).

GO TO FRAME 9

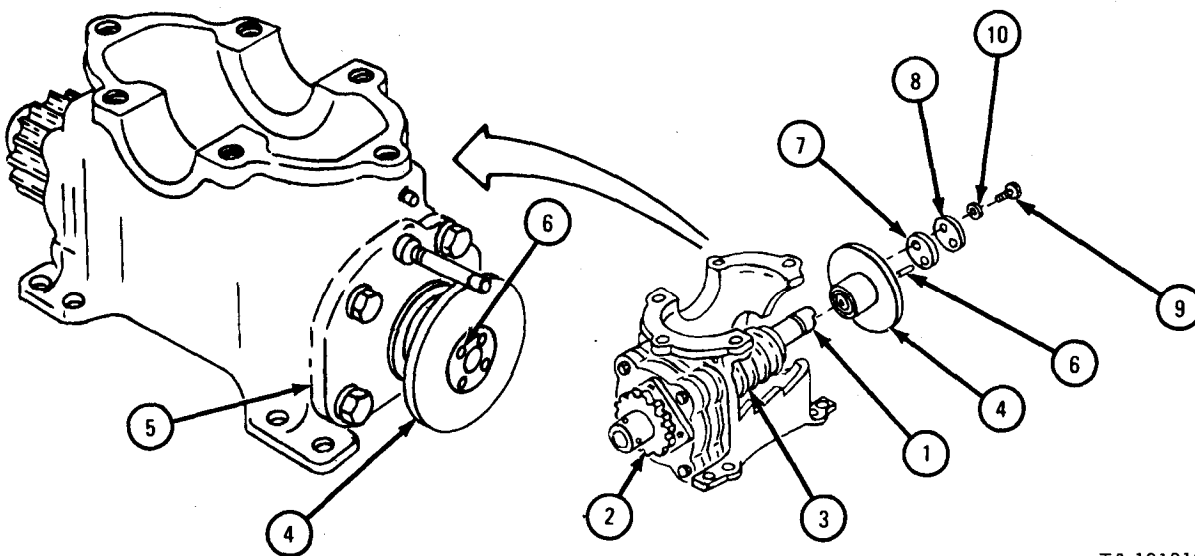

TA 101019

FRAME 9

1. Put washer (1) on each of the four adjusting bolts (2).
2. Put on four springs (3) and seats (4).
3. Put on four cotter pins (5).
4. Put on four nuts (6).

GO TO FRAME 10

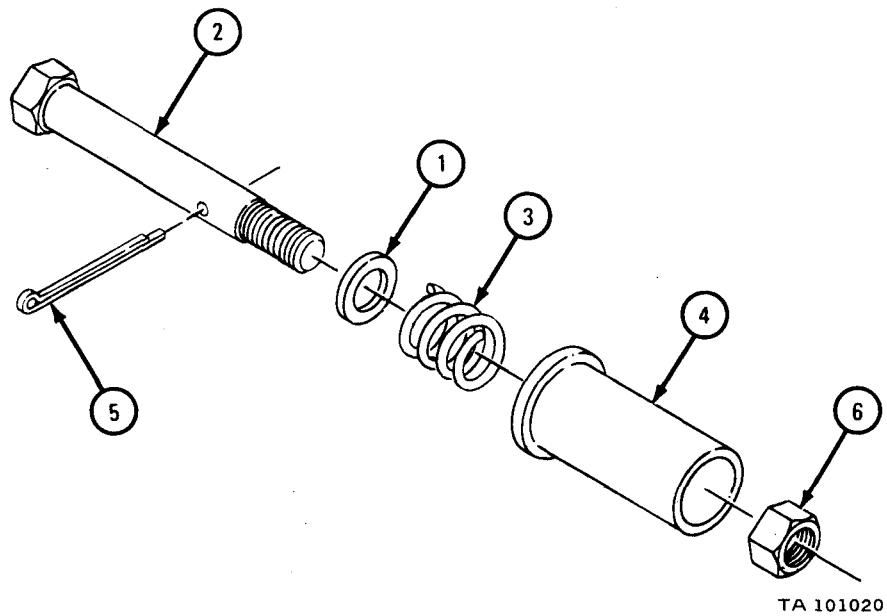

FRAME 10

1. Put in pin (1).
2. Put brake lining (2) and brake lining plate (3) on worm brake plate (4).
3. Put brake lining (5) and brake lining plate (6) on the first brake lining plate (3).
4. Put two thimbles (7) and spring (8) on brake lining plate (6) and hold in place with pressure plate (9).
5. Holding pressure plate (9) with one hand, put in adjusting bolts (10) with the other hand. Put in adjusting bolts about 1/4 inch into bearing housing.

GO TO FRAME 11

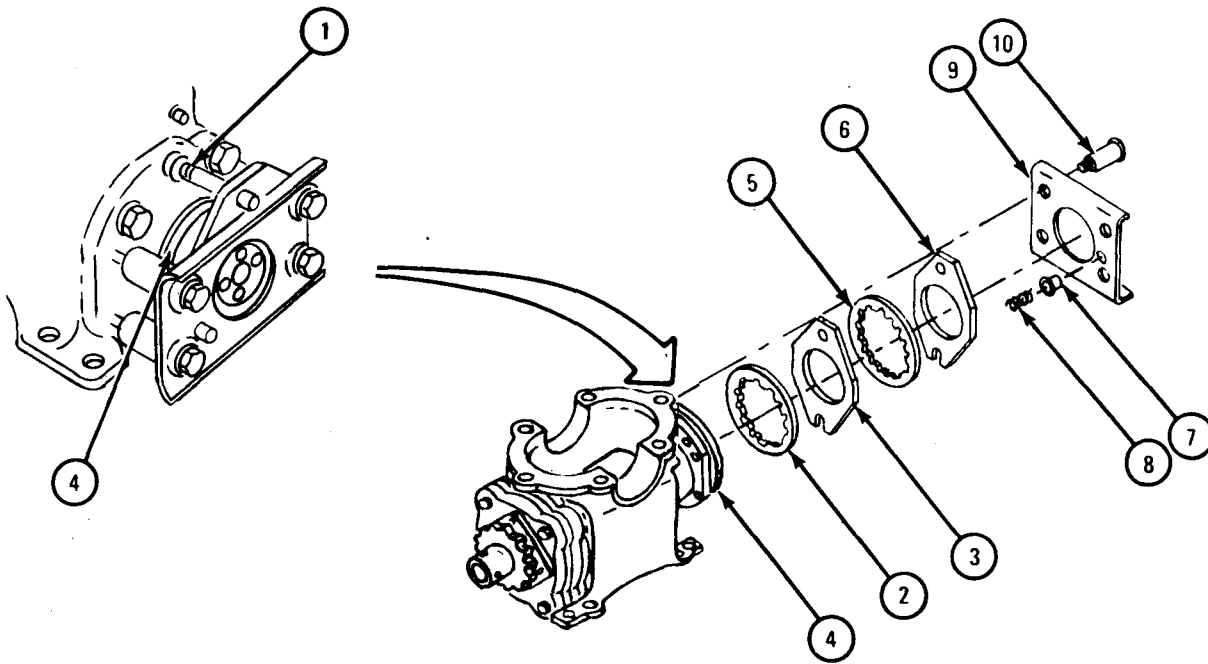

TA 101021

FRAME 11

1. Push pressure plate (1) toward housing (2) with one hand, while tightening adjusting bolts (3) with the other hand.
2. Tighten adjusting bolts (3) until stop pin (4) contacts the lug of brake stop (5).
3. Tighten each adjusting bolt (3) until there is 1/32-inch clearance between pressure plate (1) and brake lining plate (6).
4. Tighten lock nut (7) on each adjusting bolt (3).

GO TO FRAME 12

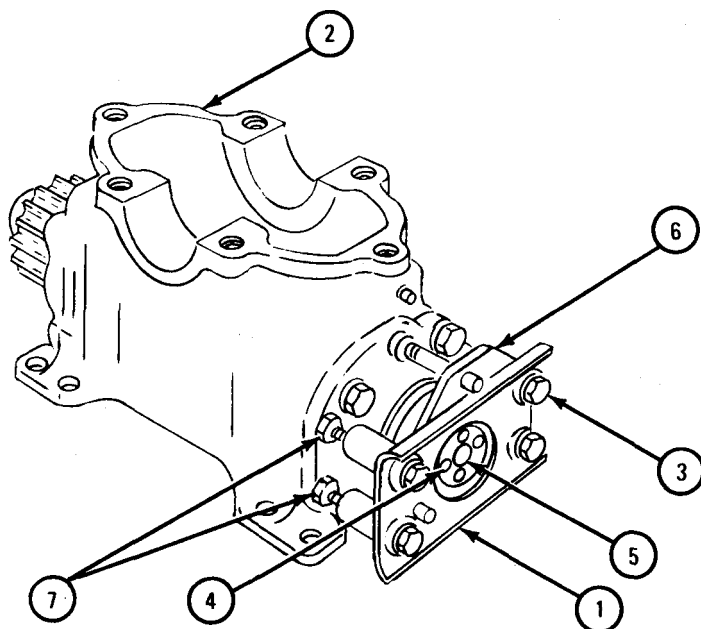

TA 101022

FRAME 12

1. If drumshaft (1) is being replaced, the two taper pin holes must be drilled in the replacement shaft.
2. Find out the location of the two tapered pin holes in the old shaft by measuring from the collar location on the drumshaft before it was taken out.
3. Drill and taper-ream these holes for pins (2 and 3).
4. Take out pin (4) from the old drumshaft (1) and press in new one.
5. If either bearing (5) was removed from end of drum (6) press in new bearing.
6. Slide collar (7) on drumshaft (1) against pin (4).
7. Slide collar (8) on drumshaft (1).
8. Put keyed end of drumshaft (1) through drum (6).
9. Slide collar (9) on drumshaft (1) and hold in place with pin (3).
10. Slide drum (6) against collar (9) and slide collar (8) against drum (6). Hold in place with pin (2).

GO TO FRAME 13

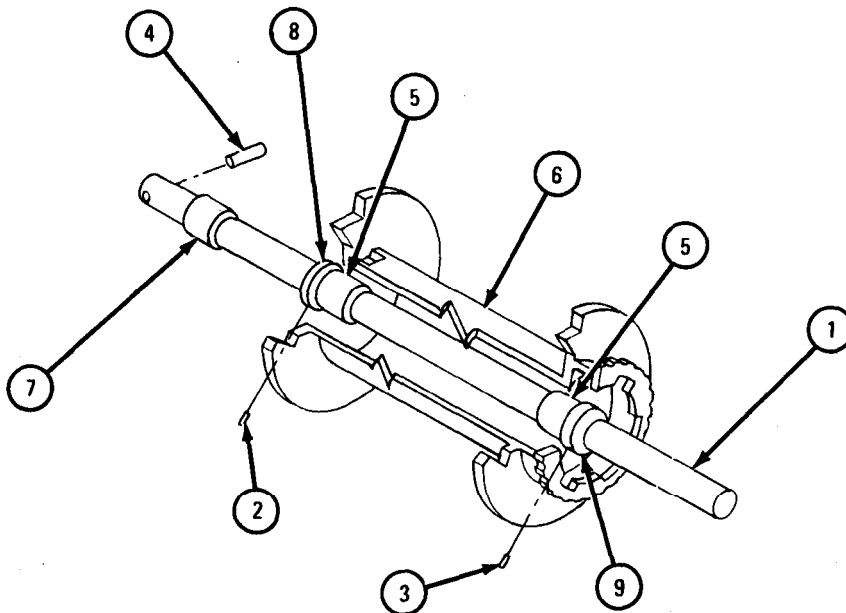

TA 101023

FRAME 13

1. If brake lining (1) was taken out, put new lining on brake plate (2) with 10 rivets (3).
2. Put sleeve (4) on hub of brake plate (2).
3. Put stop ring (5) on end of brake plate (2) and hold in place with four rivets (6).
4. Put clutch spring (7) on drumshaft (8) against collar (9).

GO TO FRAME 14

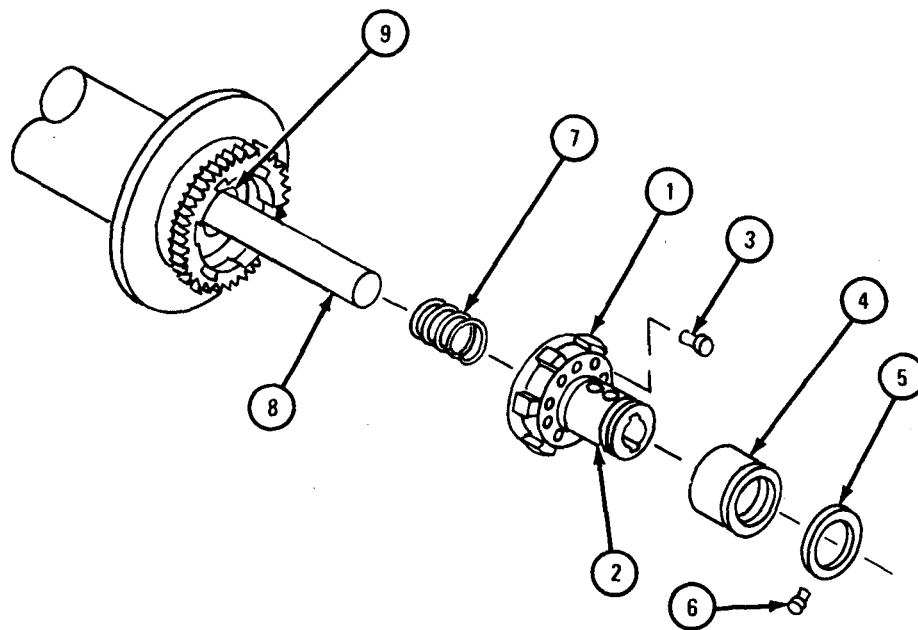

TA 101024

FRAME 14

1. Put two keys (1) on drumshaft (2).
2. Slide brake plate (3) over drumshaft (2) and keys (1).

GO TO FRAME 15

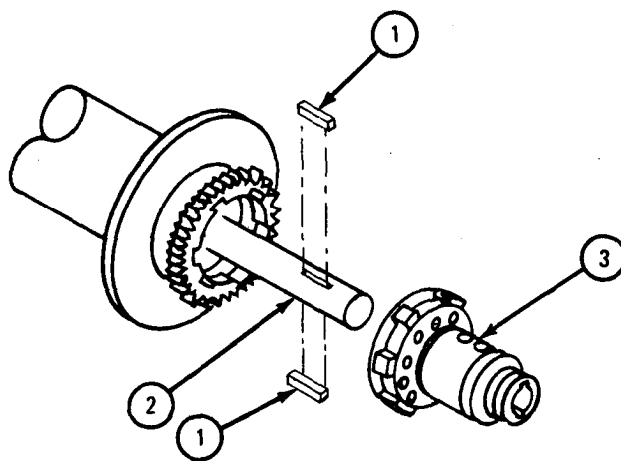

TA 101025

FRAME 15

1. Turn sleeve (1) until untapped hole in sleeve is alined with small hole in brake plate (2). Push sleeve toward brake plate and put one small ball (3) into untapped hole.
2. Turn sleeve (1) one-half turn until untapped hole is alined with other hole in brake plate (2).
3. Push sleeve (1) toward brake plate (2). Put in small ball (3), detent (4), spring (5), other detent (4), and other small ball (3).
4. Slide sleeve (1) against stopring (6). Turn sleeve until untapped hole in sleeve is alined with large hole in brake plate (2). Put one large ball (7) into untapped hole.
5. Turn sleeve (1) until tapped hole is alined with small hole in brake plate (2). Put other large ball (7) into untapped hole.
6. Put in pipe plug (8) and dog-point capscrew (9).

GO TO FRAME 16

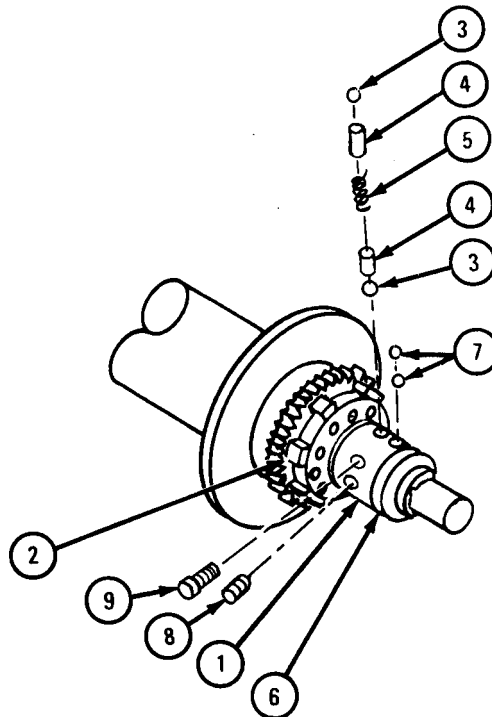

TA 105700

FRAME 16

1. Turn sleeve (1), until the tapped hole is alined with the groove in brake plate (2). Put in capscrew (3) and washer (4).
2. Be sure that capscrew (3) goes into groove in brake plate (2). Tighten capscrew.
3. Turn sleeve (1) on brake plate (2). Be sure it moves freely. If not, check capscrew (3) installation.
4. Try to turn brake plate (2) on drumshaft (5). If plate turns, take off brake plate and check keys (6) on drumshaft (5).
5. Slide sleeve (1), back and forth on brake plate (2). Sleeve must hold in two positions on clutch detent action.
6. Move sleeve (1) away from flange on brake plate (2). Clutch spring (7) must force brake plate back until plate is locked in position by clutch detents.
7. Move sleeve (1) toward flange on brake plate (2). Brake plate must force spring (7) to squeeze until detents hold plate in this second position.
8. Put further pressure in the same direction on sleeve (1). Sleeve must cause brake plate (2) to squeeze spring (7) another $5/32$ inch.
9. Back off pressure on sleeve (1). Spring (7) must force brake plate (2) back until detents hold in the second position. Plate must not snap back to first position.
10. If sleeve (1) and brake plate (2) do not move properly for all of these conditions, check clutch detent installation.

GO TO FRAME 17

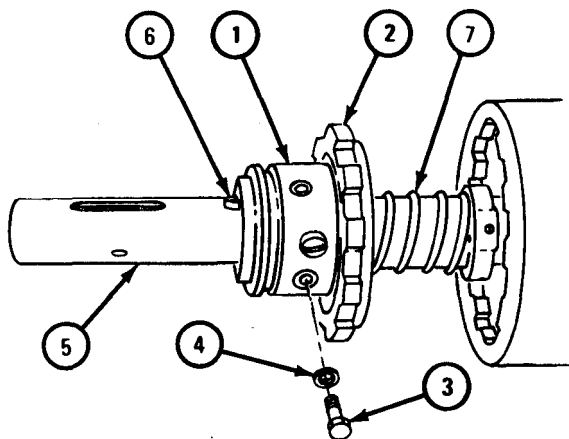

TA 101026

FRAME 17

NOTE

When putting two bushings (1) on drumshaft (2) be sure holes in bushings are on the side away from drive gear (5).

1. Slide inner bushing (1) on drumshaft (2).
2. Slide inner thrust washer (3) on drumshaft (2) against bushing (1).
3. Put key (4) on drumshaft (2).
4. If drumshaft (2) in new, press drive gear (5) on drumshaft 2 3/8 inches, between end of drumshaft and outer hub of drive gear.
5. Drill two 5/16-inch diameter holes in drumshaft (2). Use holes in drive gear (5) as a guide. Be sure holes are as deep as those in old shaft.
6. Put setscrews (6) in drive gear (5). Tighten against drumshaft (2).
7. Tie setscrews (6) and drive gear (5) together with safety wire (7).
8. Slide outer thrust washer (3) on drumshaft (2).
9. Put outer bushing (1) against gear (5).

GO TO FRAME 18

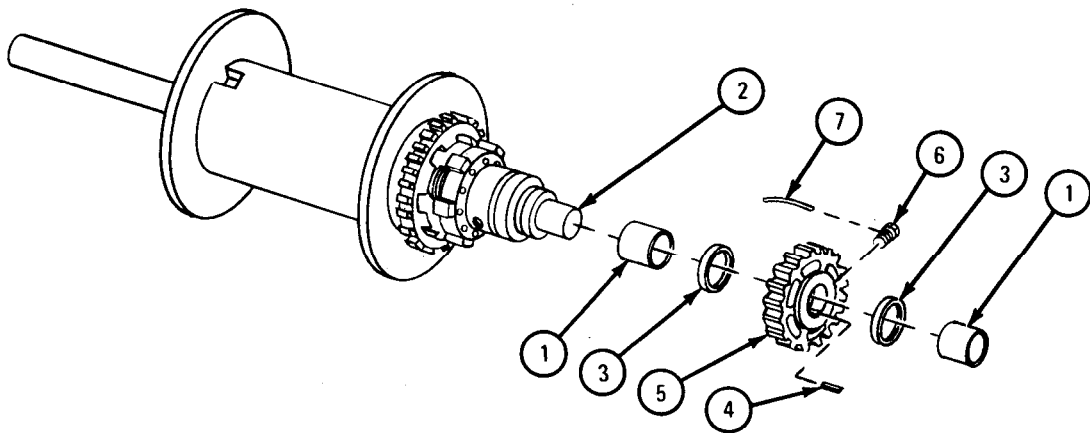

TA 101027

FRAME 18

1. Put two straight pins (1) in fork (2).
2. Place key (3) on shaft (4).
3. Place fork (2) between hinge segments of bracket (5). Aline holes.
4. Put shaft (4) through bracket (5) and fork (2).
5. Put in rivet (6) on fork (2).
6. Put on control lever (7). Put in tapered pin (8).
7. If lubrication fittings (9) were taken out, put on new ones.

GO TO FRAME 19

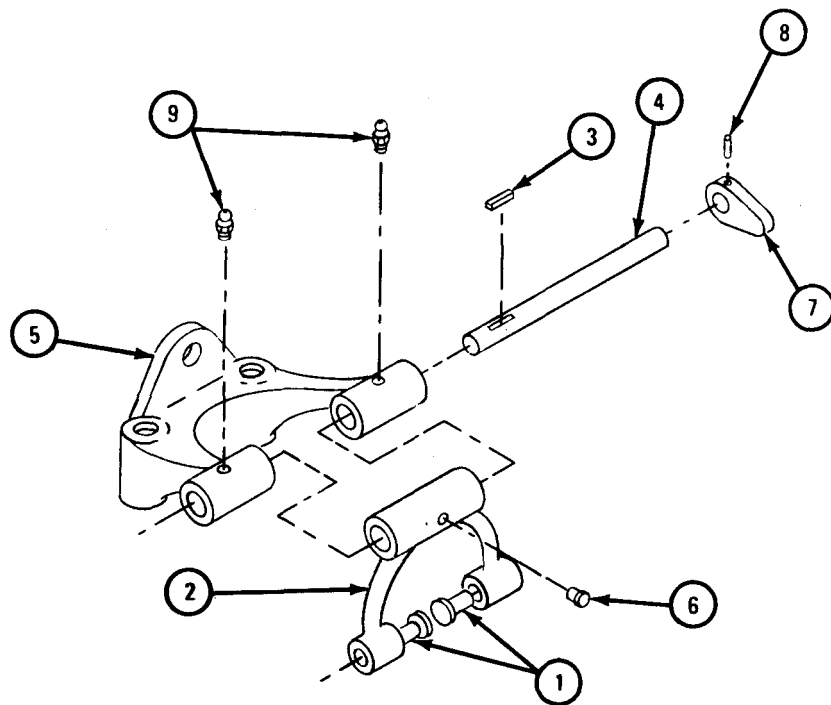

TA 101028

FRAME 19

1. Lift and hold up winch shaft and drum assembly (1), using a hoist.
2. Put drumshaft support (2) in place.
3. Lower shaft and drum assembly (1) on drumshaft support (2) and worm housing (3). At the same time, mesh drive gear with worm in worm housing (3).
4. Check that bushings are properly seated in worm housing (3).
5. Put in two bushing reducers and air valve (4).
6. Put in two pins (5).
7. Put on two worm housing gaskets (6).
8. Put cover (7) on worm housing (3).
9. Put in three washers (8) and screws (9).

GO TO FRAME 20

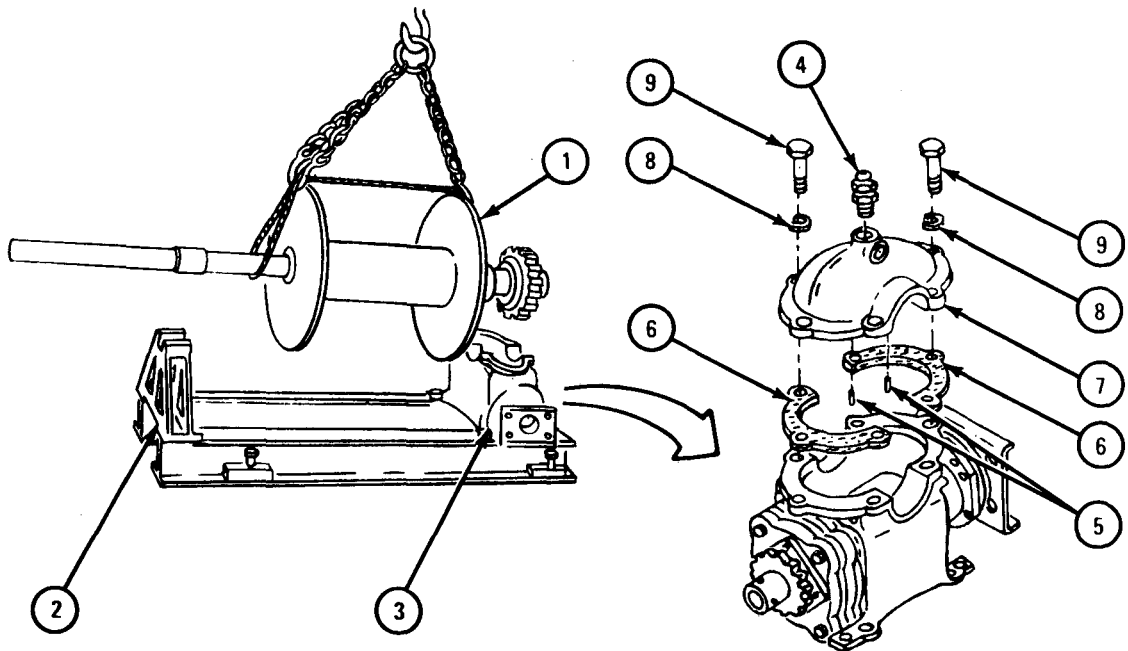

TA 101029

FRAME 20

1. Put on drumshaft support cap (1). Aline pins in cap with bushing on drumshaft (2).
2. Put in two washers (3) and screws (4).
3. Lower and take off hoist.
4. Put shifter fork assembly (5) and washer (6) on cover (7).
5. Put in three washers (8) and screws (9).
6. Fill worm gear housing with type GO 80/90 universal gear oil.
7. Grease drumshaft support fitting with type GAA, MIL-G-10924 automotive grease.

GO TO FRAME 21

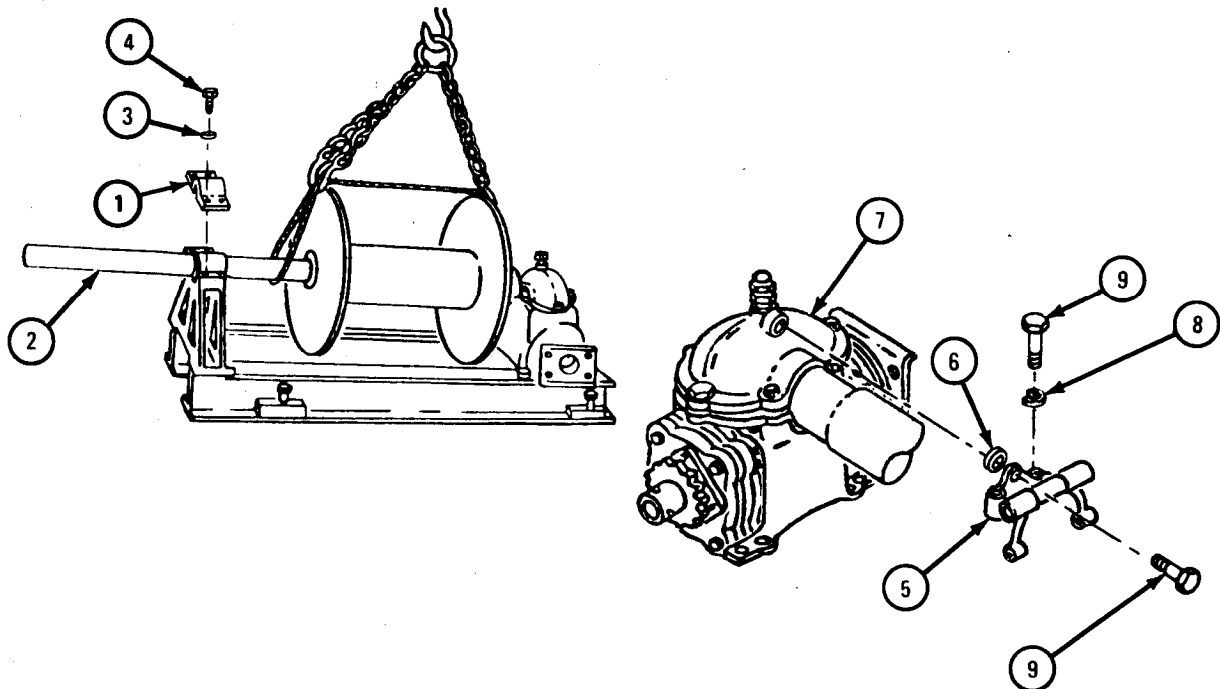

TA 101030

FRAME 21

1. If bushing (1) was removed, press new bushing into bracket (2).
2. Place sprocket (3) with washer (4) in bracket (2).
3. Put collar (5) on shaft part of sprocket (3) and hold with setscrew (6). Be sure sprocket (3) turns without any end play.
4. If bushing (7) was removed, press new bushing into bracket (8).
5. Place sprocket (9) with washer (10) in bracket (8).

GO TO FRAME 22

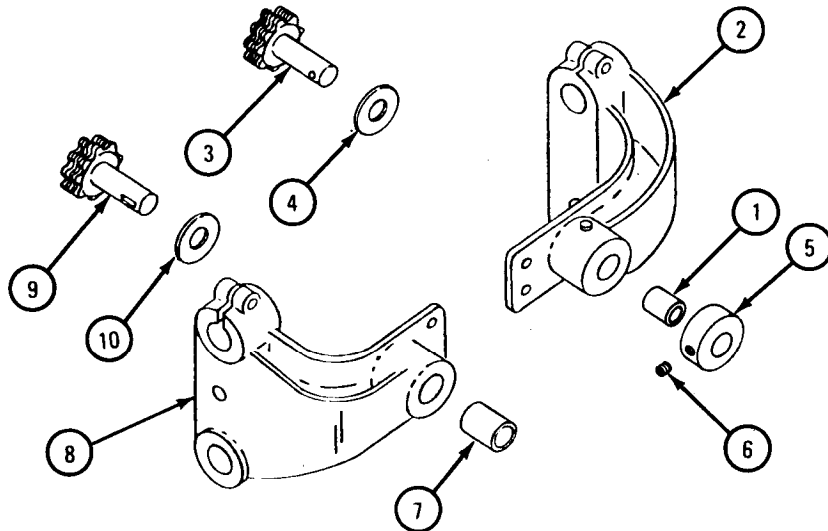

TA 101031

FRAME 22

1. Put in key (1) on shaft portion of sprocket (2).
2. Press carriage drive sprocket (3) on shaft of sprocket (2) over key (1). Put on setscrew (4).
3. Be sure that carriage drive sprocket (3) and sprocket (2) turn without end play.
4. Put bearing (5) in roller (6). Place roller (6) in roller cage (7) and hold in place with shaft (8).
5. Place cotter pins (9) on both ends of shaft (8).
6. Put in two auxiliary vertical rollers (10).

GO TO FRAME 23

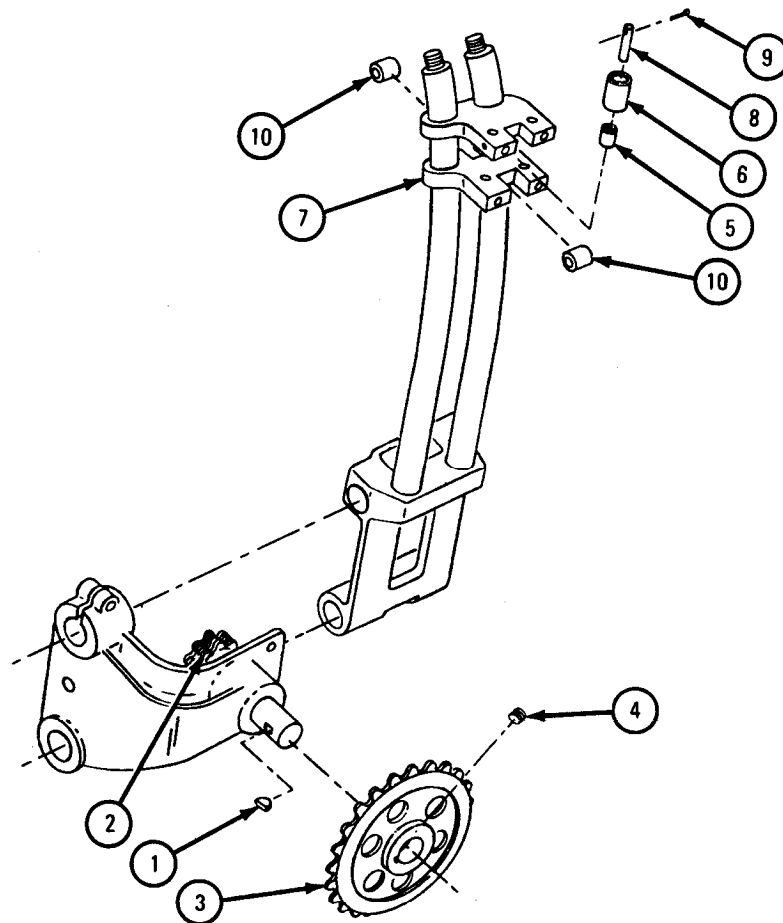

TA 101032

FRAME 23

1. Place four spacers (1) and roller guard (2) on roller cage (3).
2. Put on four capscrews (4), lockwashers (5), and flat washers (6).
3. Slide roller cage assembly (7) on carriage horns (8).

GO TO FRAME 24

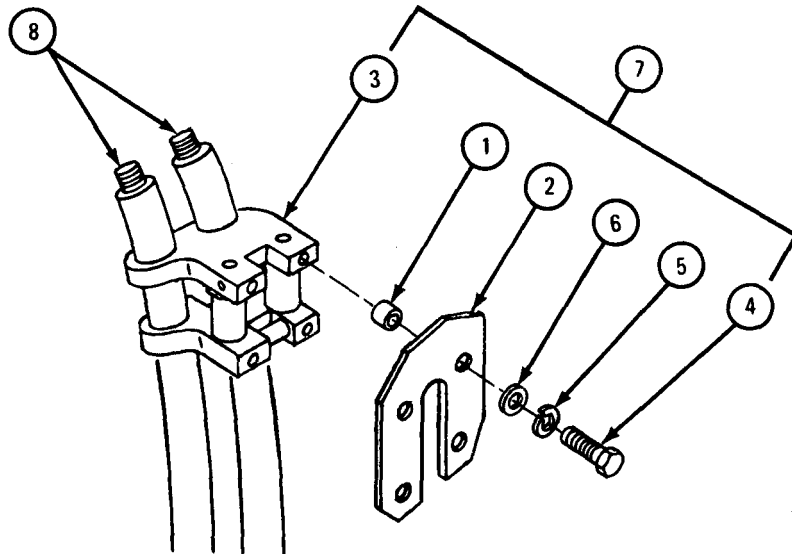

TA 101033

FRAME 24

1. Put plate (1) on carriage horns (2).
2. Put on washers (3) and nuts (4).
3. Place two wear plates (5) on lower part of carriage horns (2).
4. Put two capscrews (6) and washers (7) onto each wear plate (5).
5. Place left-hand bracket (8) on tie rods (9).
6. Be sure the longest tie rod is placed in upper hole of bracket (8).

GO TO FRAME 25

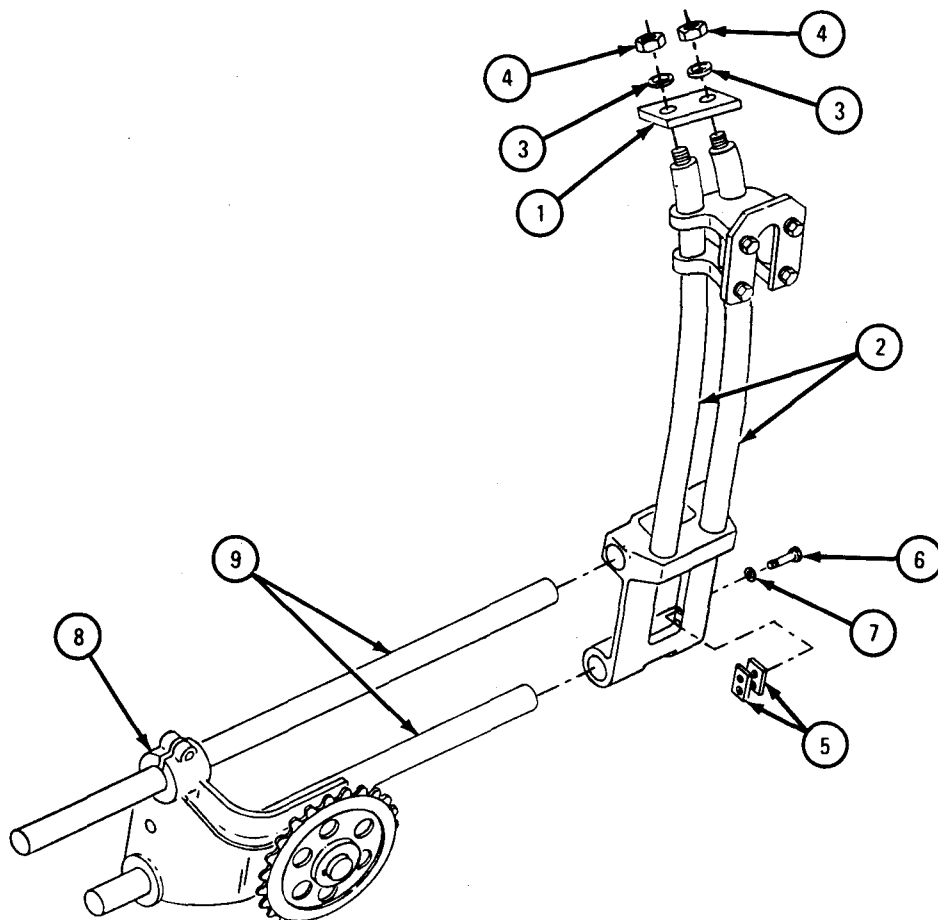

TA 101034

FRAME 25

1. Place main drive support (1) on end of tie rods (2 and 3). Aline holes in tie rods with holes in support.
2. Join upper tie rod (2) to main drive support (1) with capscrew (4) and nut (5).
3. Join lower tie rod (3) to main drive support (1) with capscrew (6) and nut (7).
4. Put adjusting capscrew (8), washer (9), and nut (10) in main drive support (1). Do not tighten.

GO TO FRAME 26

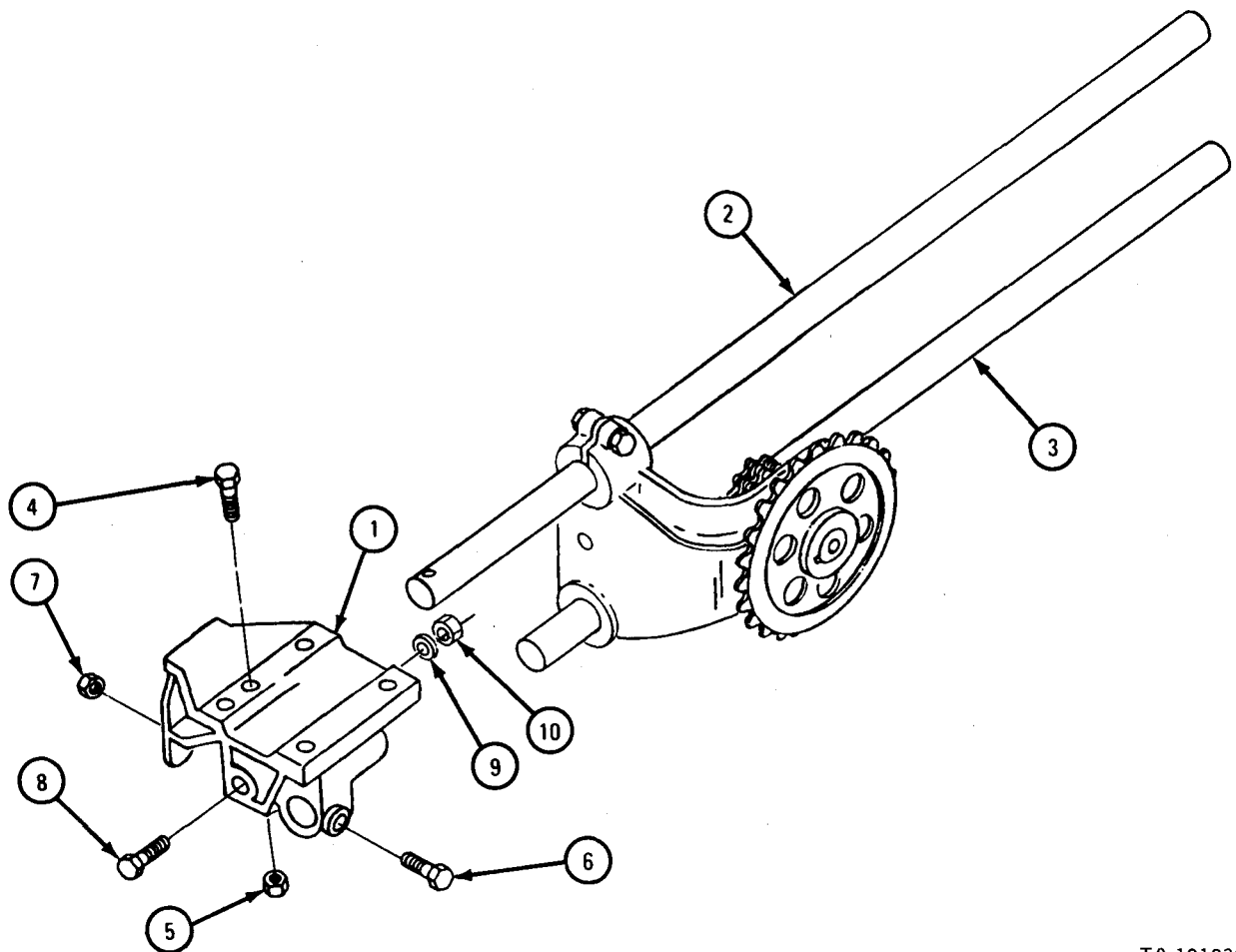

TA 101035

FRAME 26

1. Slide left-hand bracket (1) toward main drive support (2) until bracket touches adjusting capscrew (3).
2. Put on capscrew (4), washer (5), and nut (6). Do not tighten.
3. Put on capscrew (7), washer (8), and nut (9). Do not tighten.

GO TO FRAME 27

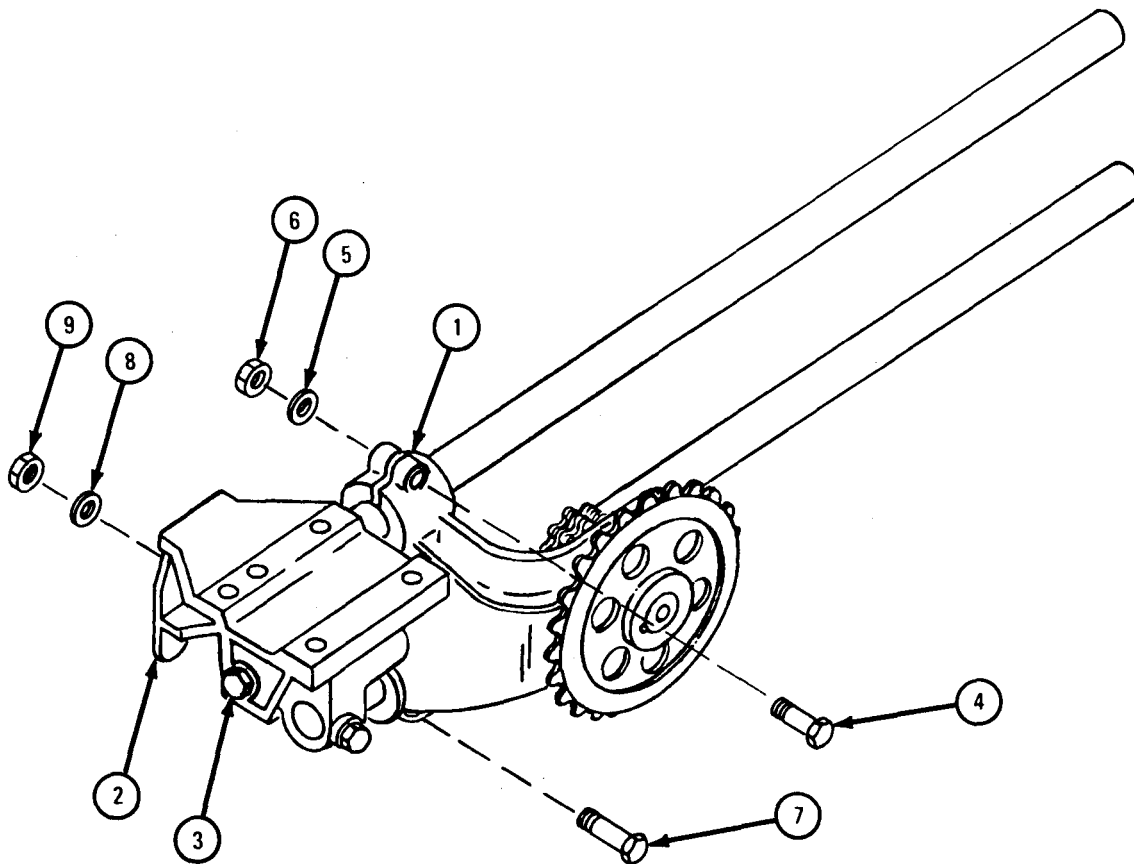

TA 101036

FRAME 27

1. Slide carriage roller assembly (1) on tie rods (2 and 3).
2. Slide right-hand bracket (4) on tie rods (2 and 3).
3. Position tie rod support (5) on ends of tie rods (2 and 3). Tie rods must extend 1/4 inch beyond support.
4. Tighten two setscrews (6) against tie rods (2 and 3). Tighten nuts (7).
5. Slide right-hand bracket (4) toward tie rod support (5) until bracket touches adjusting capscrew (8). There should be 3/4-inch clearance between bracket and support.
6. Put on two capscrews, washers, and nuts (9). Do not tighten.
7. Slide carriage roller assembly (1) back and forth across tie rods (2 and 3) to make sure that carriage moves without binding.
8. If carriage binds at either or both ends of tie rods (2 and 3), place shim stock between tie rods and tie rod support (5), and between tie rods and main drive support (10).

GO TO FRAME 28

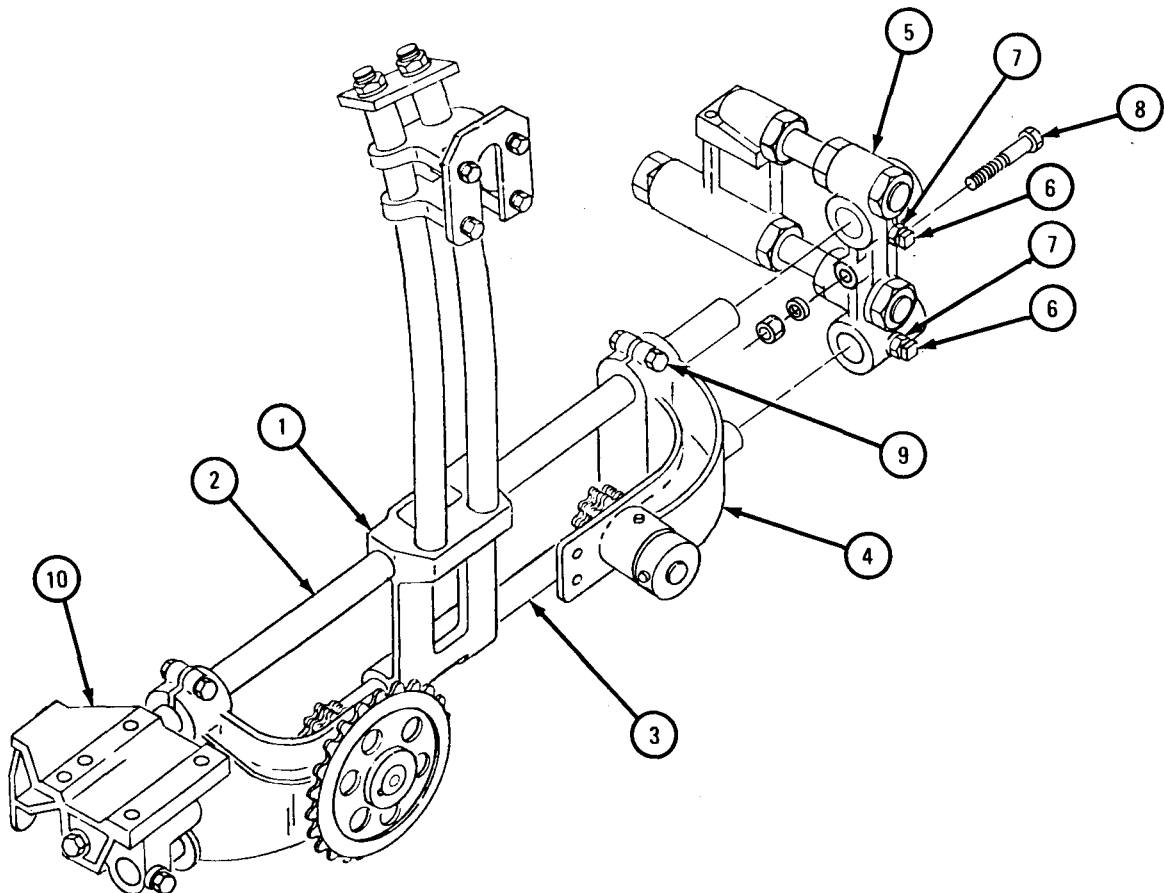

TA 101037

FRAME 28

1. Put hoist on tie rods (1). Lift carriage level winder assembly (2).
2. Lower carriage level winder assembly (2) on rear winch.
3. Put two capscrews (3) and washers (4) on support (5).
4. Put on capscrew, lockwasher, and flat washer (6).
5. Put on capscrew (7) and washer (8).
6. Take off hoist.
7. Oil all cups on carriage level winder assembly with lubricating oil, type ICE, OE/HDO 10, MIL-L-2104.
8. Grease carriage guide pins and wear plates with automotive grease, type GAA, MIL-G-10924.
9. Put on washer (9) and nut (10).

GO TO FRAME 29

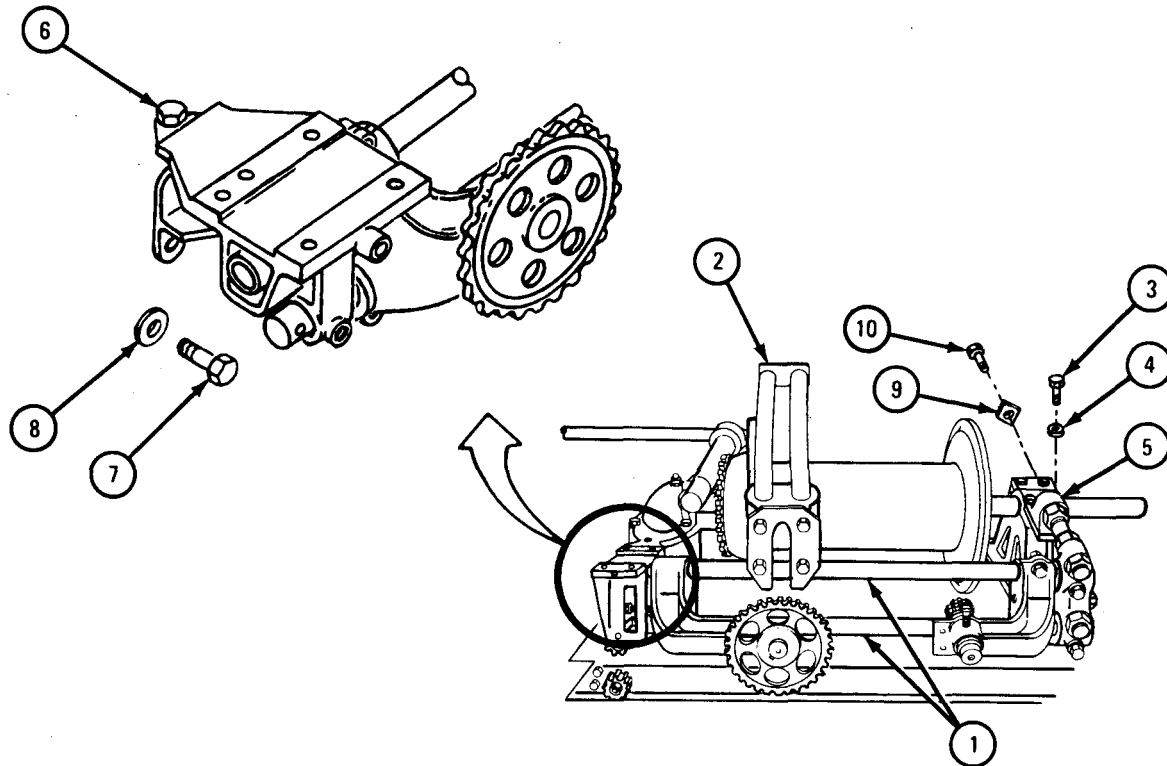

TA 101038

FRAME 29

1. Place mounting plate (1) on main drive support (2).
2. Put on two capscrews (3) and two capscrews (4) with washers (5).
3. Lower speed reducer assembly (6) on mounting plate (1). Aline mounting holes.
4. Put on four capscrews (7) and washers (8).

GO TO FRAME 30

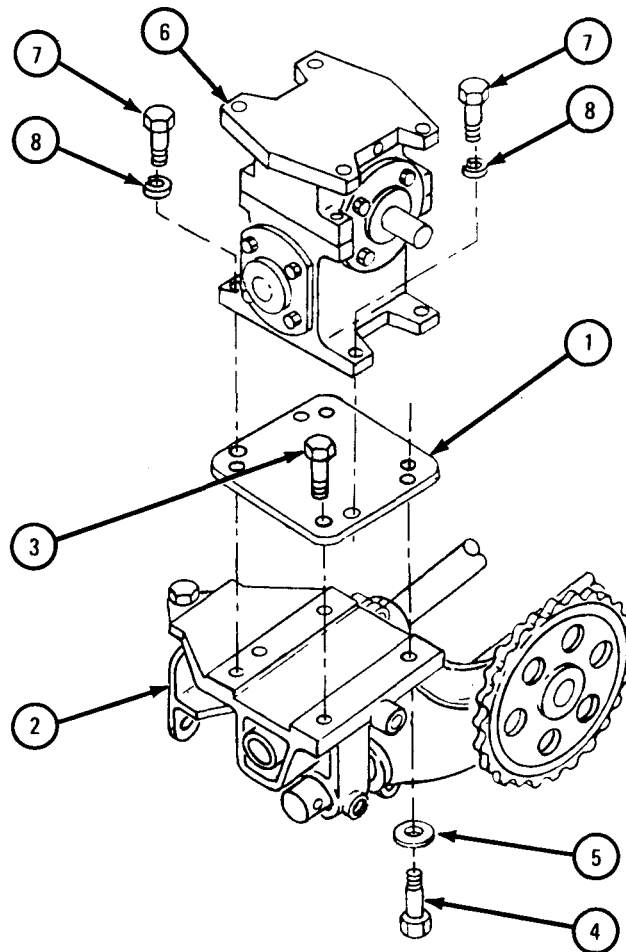

TA 101039

FRAME 30

1. If bushings (1) were taken out, press new bushings into bracket (2).
2. If shaft (3) was removed from sprocket (4), put key (5) into shaft and press on sprocket.
3. Put on setscrews (6).
4. Put shaft (3) into bracket (2).
5. Put on collar (7). Tighten setscrew (8).
6. Place bracket (2) over shaft (9).
7. Put key (5) into shaft (9).
8. Put on sprocket (10). Tighten setscrews (6).

GO TO FRAME 31

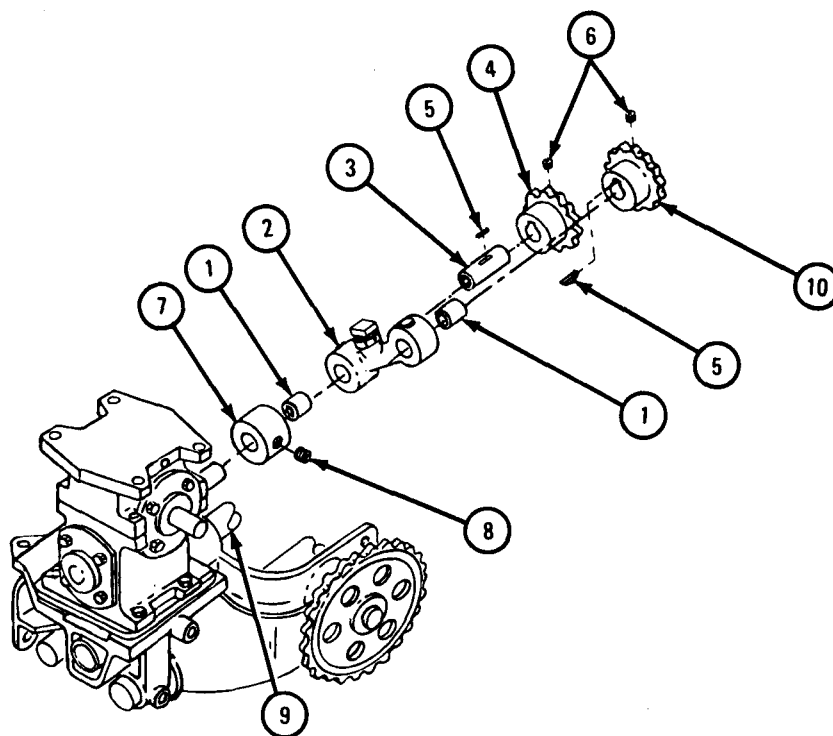

TA 101040

FRAME 31

1. If bushings (1 and 2) were taken out of bracket (3), press in new bushings.
2. If shaft (4) was taken out of sprocket (5), place key (6) on shaft and press shaft into sprocket.
3. Put on setscrew (7).
4. Put shaft (4) through bracket (3) and put on collar (8).
5. Put on setscrew (9).

GO TO FRAME 32

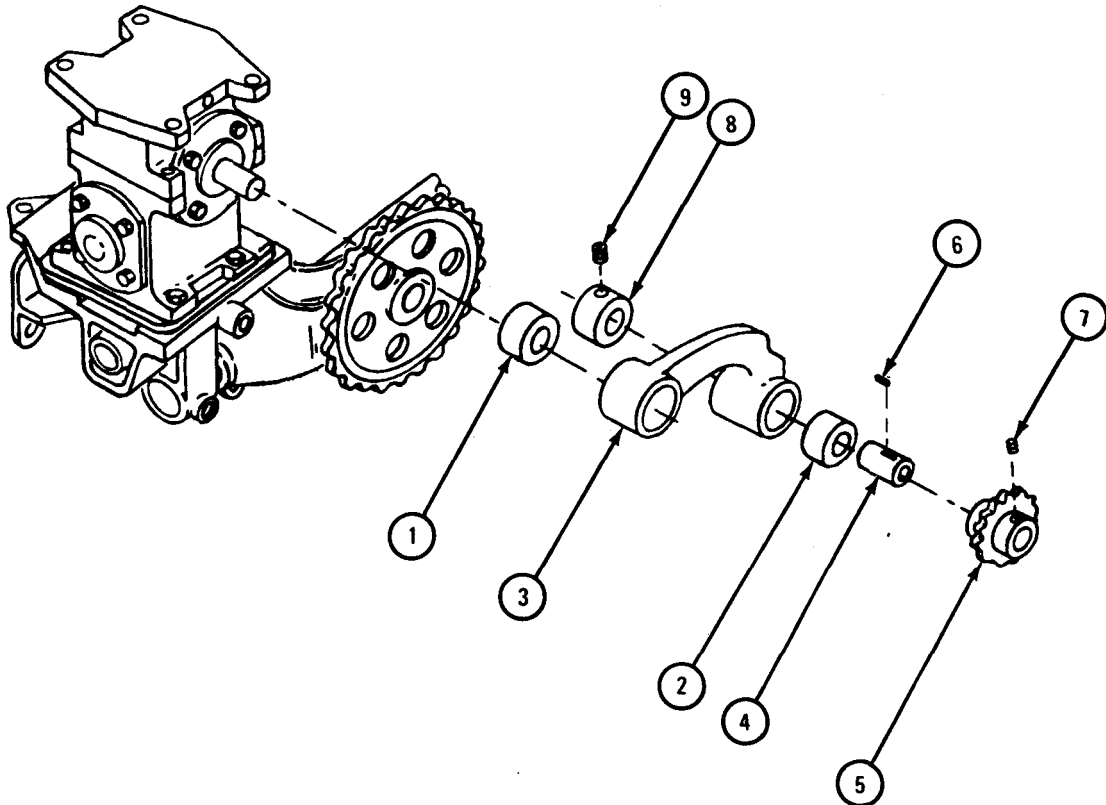

TA 101041

FRAME 32

1. Slide rod (1) into bracket assembly (2).
2. Put on washer (3) and nuts (4).
3. Place bracket assembly (2) on shaft (5).
4. Place key (6) on shaft (5).
5. Press sprocket (7) on shaft (5). Be sure to aline key (6) with keyway in sprocket.
6. Put on setscrew (8).
7. Put on capscrew (9) and washers (10) to hold rod (1) to housing.

GO TO FRAME 33

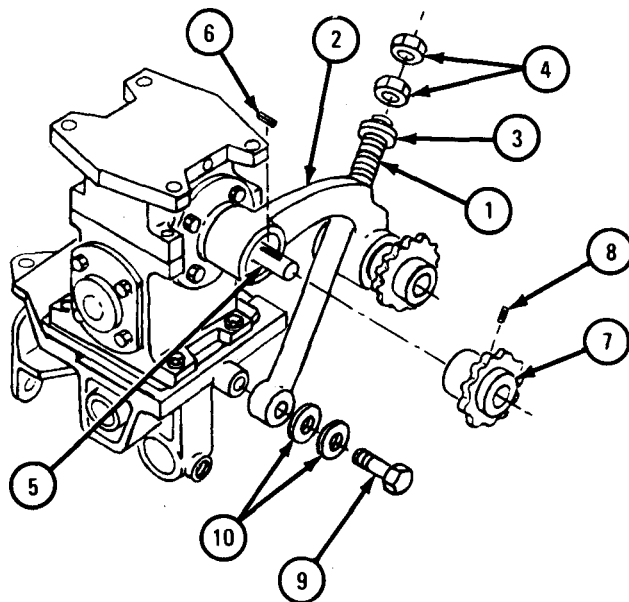

TA 101042

FRAME 33

1. Place seal (1) in groove of bearing retainer (2).
2. If retaining rings (3) were taken out of idler pulley (4), put on retaining rings.
3. If bearing cups (5) were taken out, press new cups into idler pulley (4).
4. Pack tapered roller bearings (6) with type GAA, MIL-G-10924 automotive grease.
5. Put bearings (6) into bearing cups (5).
6. Place idler pulley (4) on pulley shaft (7).
7. Place seal (1) in groove of bearing retainer (8).
8. Place bearing retainer and nut (8) on pulley shaft (7). Tighten nut so pulley turns without end play in bearing.
9. Put on cotter pin (9).

NOTE

Idler pulley and bracket assembly will be installed during follow-on tasks.

END OF TASK

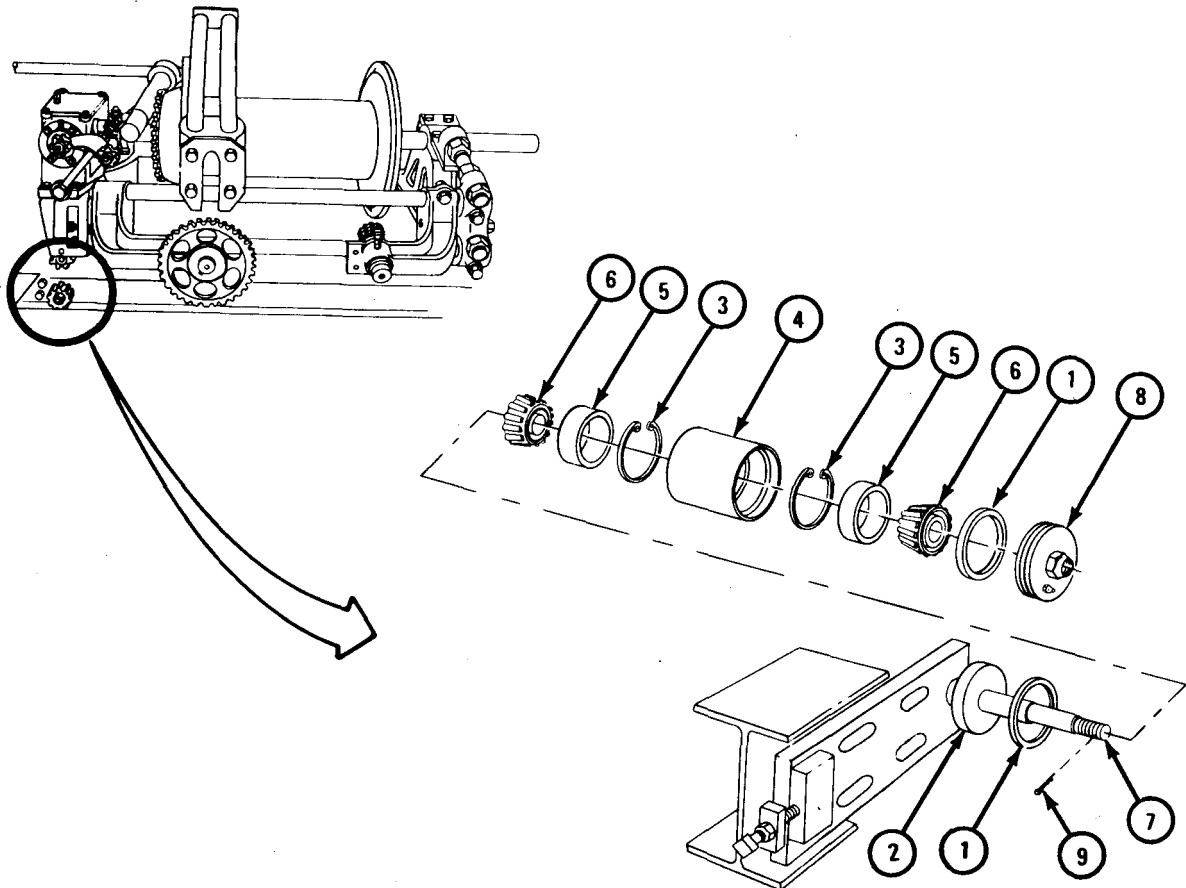

TA 101043

g. Replacement.

FRAME 1

1. Place cable tensioner (1) on mounting frame (2).
2. Put on capscrew, nut, and washer (3).
3. Place lifting chains around drumshaft. Mate lifting chains to a hoist.
- Soldier A 4. Hold cable tensioner (1) away from rear winch (4).
- Soldier B 5. Lift rear winch (4) off work table and lower onto truck bed. Aline rear winch mounting holes with mounting frame holes.
- Soldier A 6. Put on eight capscrews, washers, and nuts (5), joining drumshaft support (6) to mounting frame (2).
- Soldier B 7. Put on eight capscrews, washers, and nuts (7), joining worm housing (8) to mounting frame (2).
8. Take off lifting chains and hoist.

GO TO FRAME 2

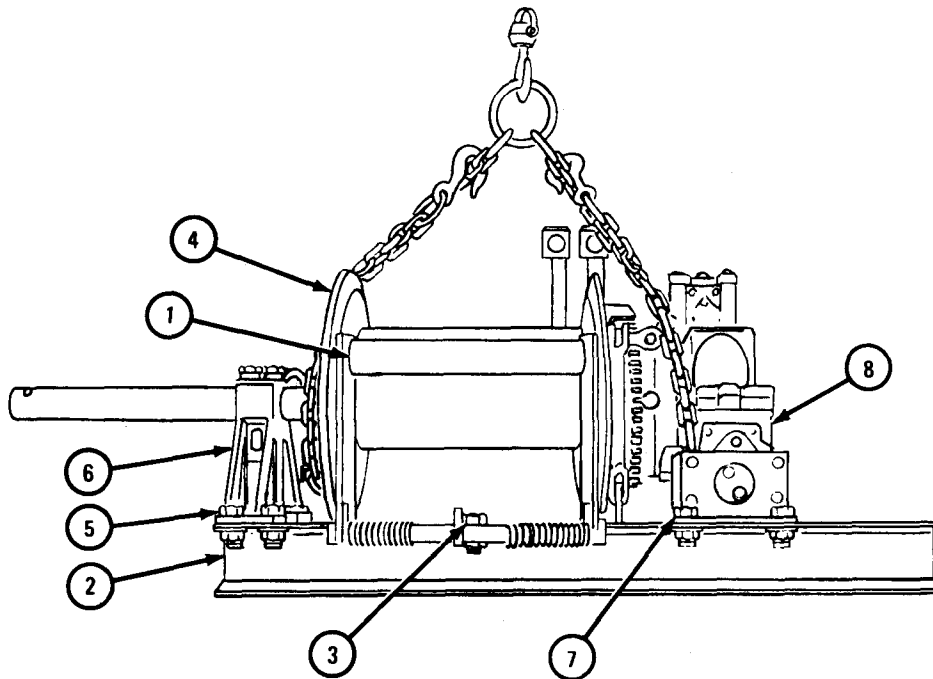

TA 101044

FRAME 2

1. Join control rod (1) to eyebolt (2).
2. Put pin (3) through control rod (1) and eyebolt (2).
3. Put on cotter pin (4).
4. Place cover (5) on truck body and hold in place with four capscrews (6).

NOTE

Follow-on Maintenance Action Required:

1. Replace carriage cross chains. Refer to TM 9-2320-209-20.
2. Adjust carriage cross chains. Refer to Carriage Travel Adjustment, TM 9-2320-209-20.
3. Replace winch cable. Refer to TM 9-2320-209-20.
4. Replace reduction drive chains. Refer to TM 9-2320-209-20.
5. Adjust reduction drive chains. Refer to TM 9-2320-209-20.
6. Replace winch drive chain. Refer to para 18-6.
7. Replace power divider. Refer to para 18-12.
8. Replace cab protector. Refer to TM 9-2320-209-20.

END OF TASK

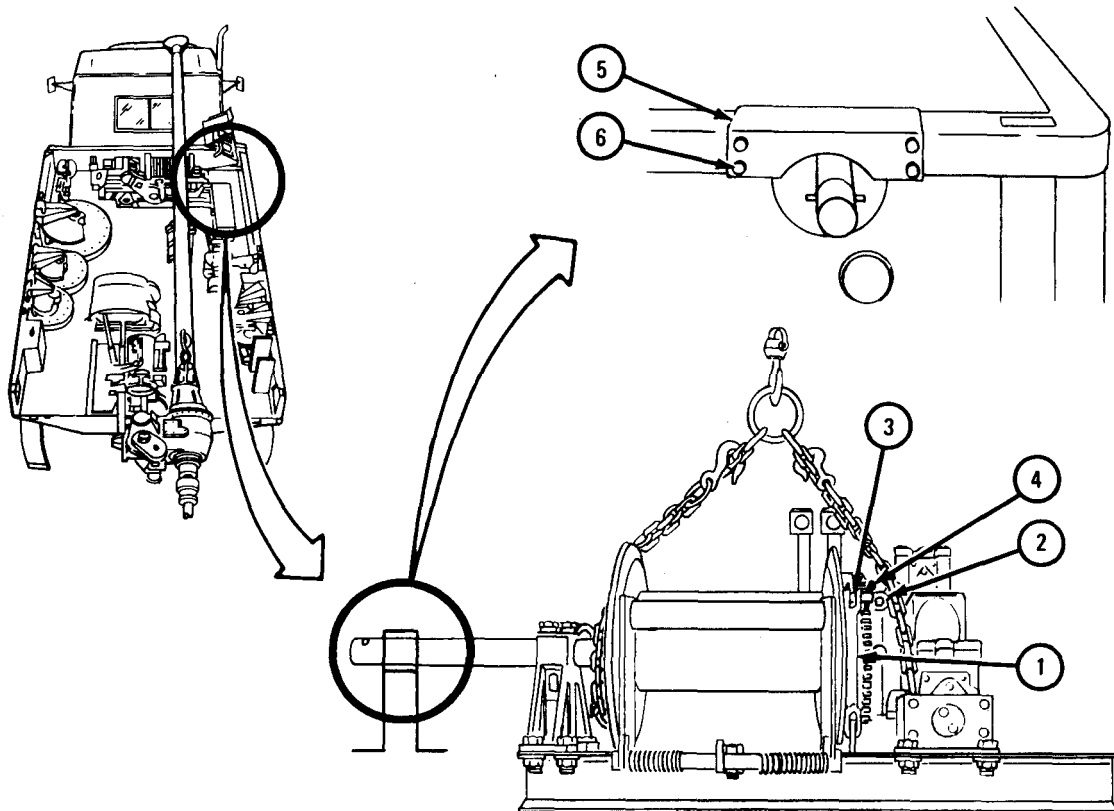

TA 101045

h. Testing.

FRAME 1

NOTE

Test rear winch mounted on the truck. Use winch control lever on truck to mesh clutch when testing drum clutch and brake. To turn on power to rear winch, refer to operators manual, TM 9-2320-209-10/1.

WARNING

Always wear leather gloves when handling cable. Otherwise, injury to hand could result.

- Soldier A 1. Unwind 10 feet of cable (1), by hand.
- Soldier B 2. Turn on power to rear winch. Turn locking latch (2) to the unlocked position. Push control lever (3) forward. Put on locking latch.
- Soldier A 3. While soldier B is unlocking latch (2), turn drum (4) by hand. The clutch must mesh.
4. If clutch does not mesh properly, shut down power. Take out drum and shaft assembly (4 and 5). Refer to para 18-5c, frames 11 through 14.
5. Make sure clutch and brake plate spring are put in correctly. Refer to para 18-5f, frames 13 through 15.
6. Assemble drum and shaft assembly (4 and 5). Refer to para 18-5f, frames 16 through 19.
7. Do steps 1 through 6 again.

GO TO FRAME 2

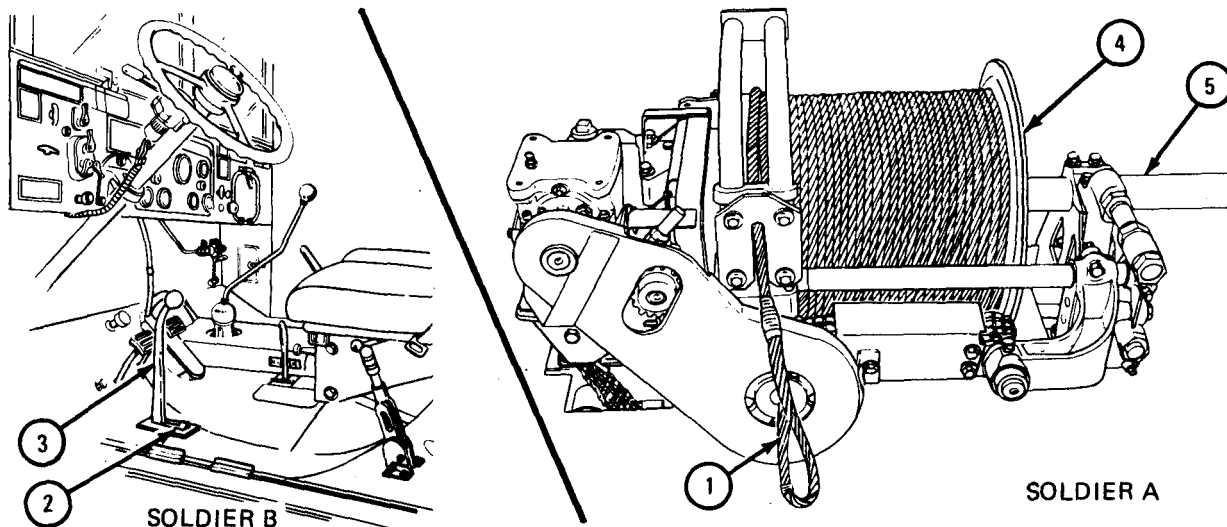

TA 101046

FRAME 2

- Soldier A 1. Turn on power to rear winch. Turn locking latch (1) to the unlocked position. Pull control lever (2) toward seat. Put on locking latch.
- Soldier B 2. Turn drum (3). The drum must be free of clutch and brake plate (4) and turn easily.
3. If clutch and brake plate (4) touches drum (3), shut down power. Take out drum and shaft assembly (3 and 5). Refer to para 18-5c, frames 11 through 14.
4. Check that clutch and brake plate (4) are working correctly. Refer to para 18-5f, frame 16.
5. If necessary, take apart clutch and brake plate (4). Refer to para 18-5c, frames 16 and 17.
6. Check clutch detent sleeve (6). Refer to para 18-5e, frame 8.
7. Assemble clutch and brake plate (4). Refer to para 18-5f, frames 13 through 15.
8. Assemble drum and shaft assembly (3 and 5). Refer to para 18-5f, frames 16 through 19.
9. Do para 18-5h, frame 1 again. Do steps 1 through 8 again.

GO TO FRAME 3

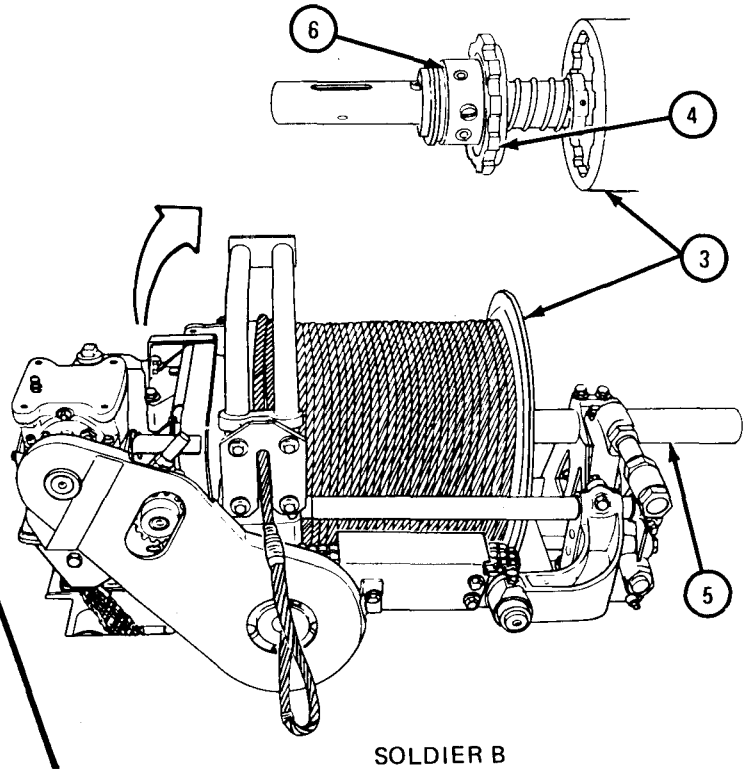
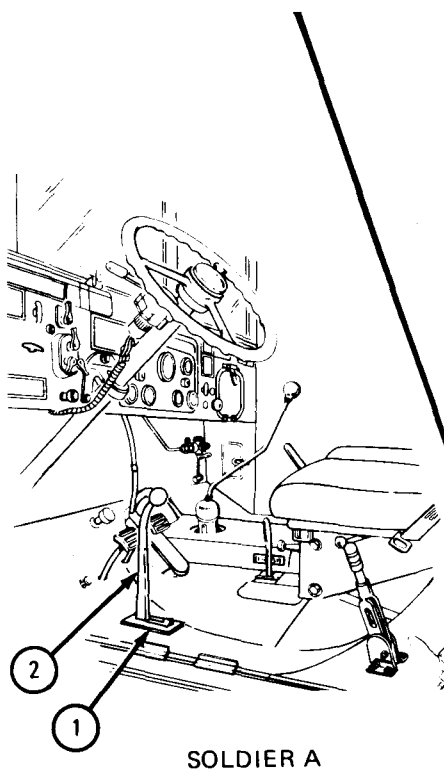

TA 101047

FRAME 3

- Soldier A 1. Turn on power to rear winch. Turn locking latch (1) to the unlocked position. Push control lever (2) forward. Put on locking latch.
- Soldier B 2. While soldier A is unlocking latch, turn drum (3) by hand.
 3. Drum must stop turning when drum and clutch mesh.
 4. If brake does not hold, shut down power. Take out drum and shaft assembly (3 and 4). Refer to para 18-5c, frames 11 through 14.
 5. Take apart clutch and brake plate (5). Refer to para 18-5c, frames 16 through 18.
 6. Check thickness of brake lining (6). Refer to para 18-5e, frame 9.
 7. Check that lining (6) is properly riveted to clutch and brake plate (5).
 8. Assemble clutch and brake plate (5). Refer to para 18-5f, frames 13 through 15.
 9. Assemble drum and shaft assembly (3 and 4). Refer to para 18-5f, frames 16 through 19.
 10. Do para 18-5h, frames 1 through 3 again.

GO TO FRAME 4

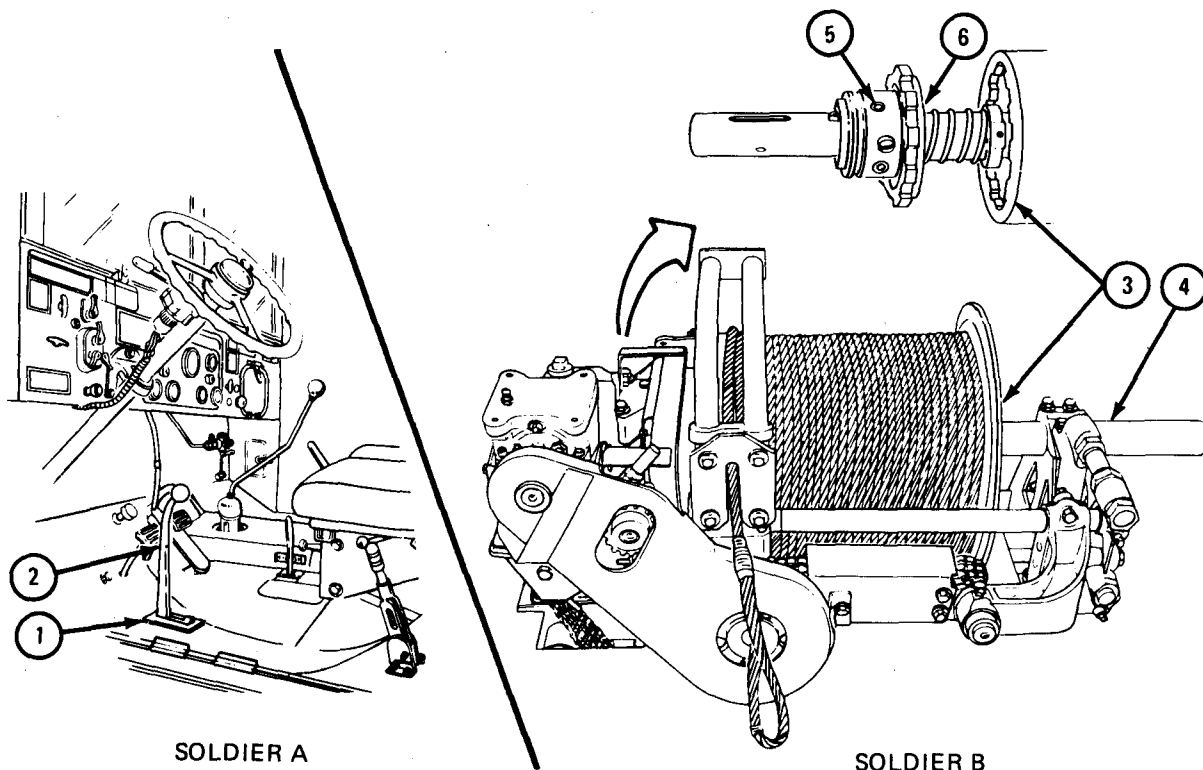

TA 101048

FRAME 4

- Soldier A
1. Turn on power to rear winch. Turn locking latch (1) to the unlocked position. Push control lever (2) forward and put on locking latch.
 2. Operate winch and turn drum, first in one direction, then the other.
- Soldier B
3. Check if automatic brake pressure plate (3) and brake lining plate (4) touch.
 4. If there is contact, shut down power. Adjust pressure plate clearance. Refer to para 18-5f, frame 11.

GO TO FRAME 5

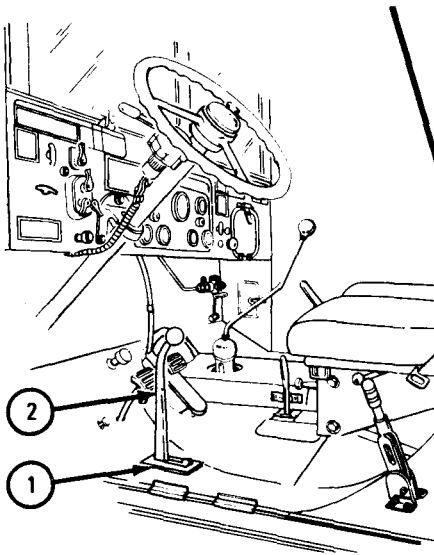

SOLDIER A

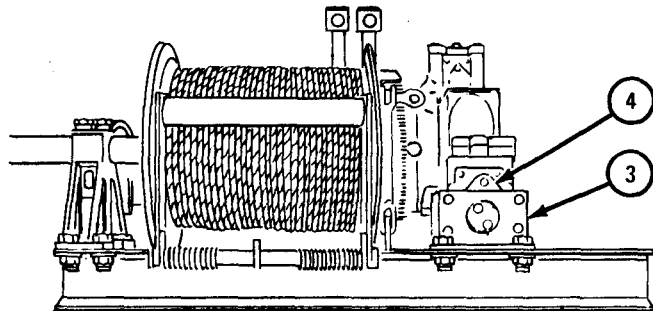

SOLDIER B

TA 101049

FRAME 5

- Soldier A 1. Turn on power to rear winch. Turn locking latch (1) to the unlocked position. Push control lever (2) forward and put on locking latch.
- Soldier B 2. Put a 1,000-pound weight (3) on end of cable (4).

WARNING

Do not let go of winch clutch with a weight suspended from cable. Weight could fall and cause personnel injury and equipment damage.

- Soldier A 3. Operate rear winch to lift weight.
- Soldier B 4. Check that there is no contact between automatic brake pressure plate (5) and brake lining plate (6).
5. If contact is made, lower weight to the ground and shut down power. Adjust pressure plate clearance. Refer to para 18-5f, frame 8.

GO TO FRAME 6

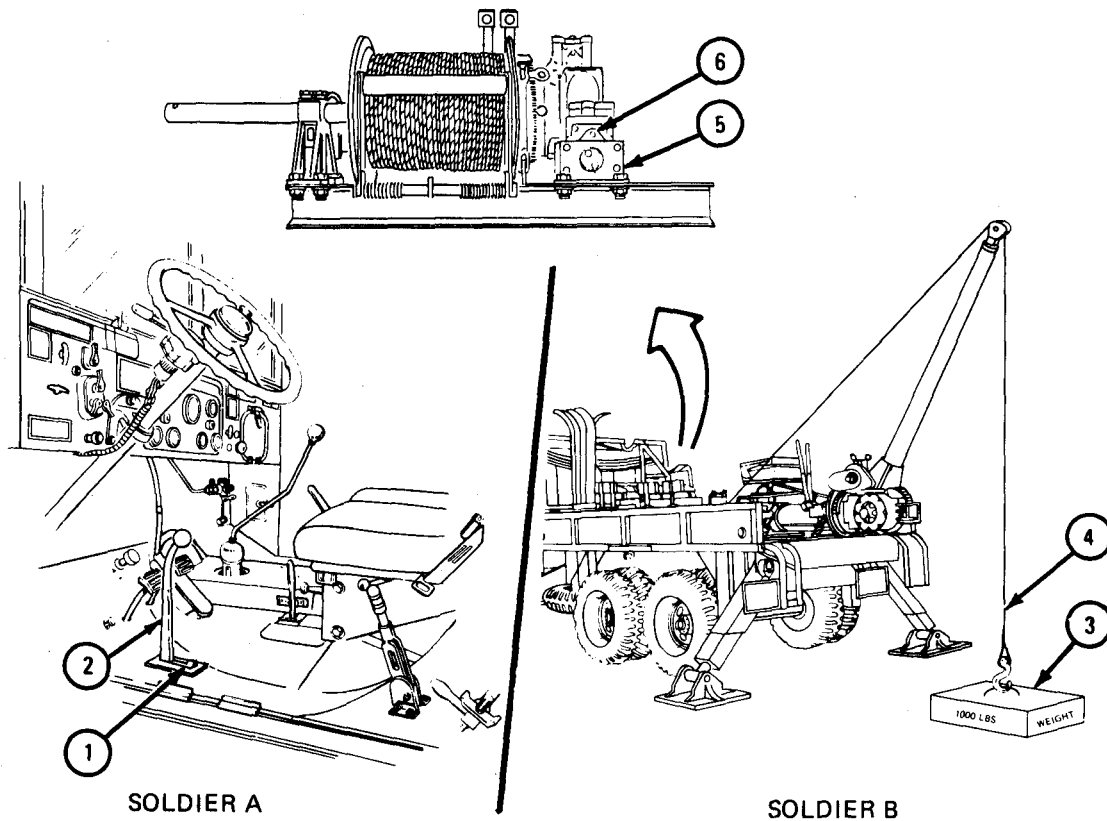

TA 101050

FRAME 6

- Soldier A
1. Turn on power to rear winch. Turn locking latch (1) to the unlocked position. Push control lever (2) forward and put on locking latch.

WARNING

Do not let go of winch clutch with a weight suspended from cable. Weight could fall and cause personnel injury and equipment damage.

2. Operate rear winch to lift weight.
3. With weight suspended off ground. Shut down power.
4. Check that automatic brake (3) holds weight (4) on cable (5) for creeping.
5. If winch causes weight (4) to creep, lower weight to ground. Check pressure plate clearance and adjust automatic brake. Refer to para 18-5f, frame 11.

END OF TASK

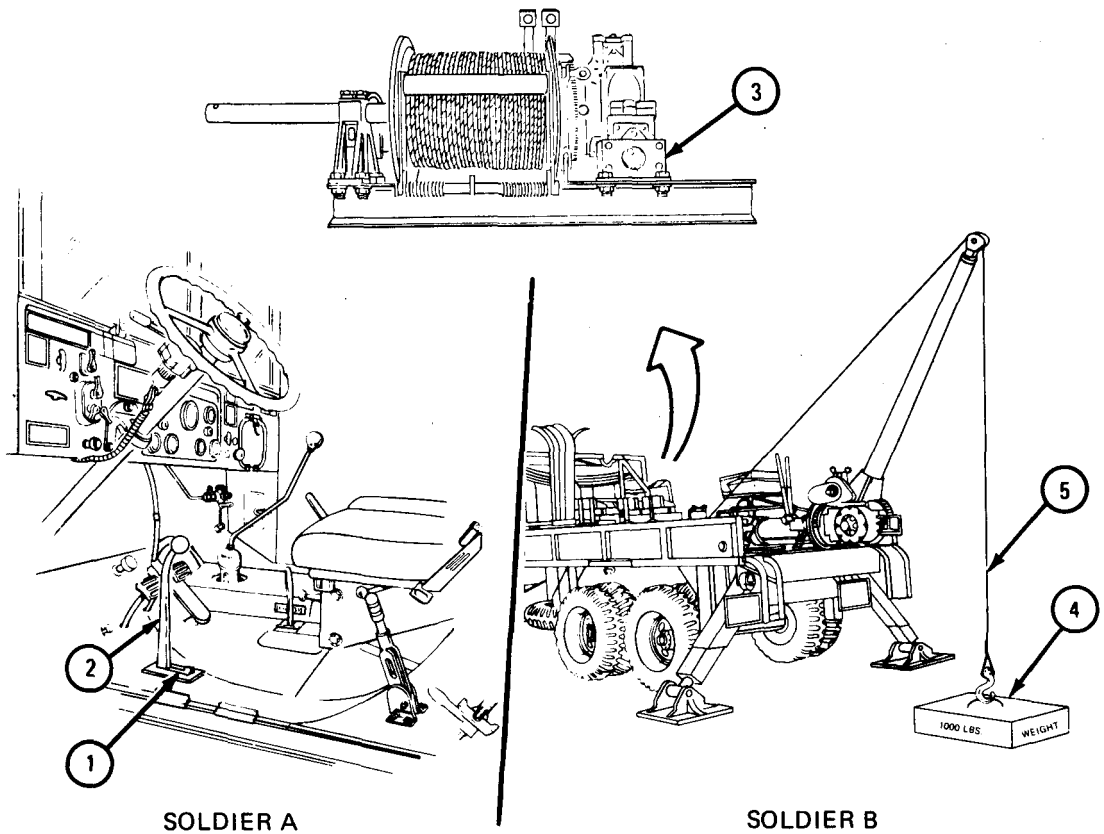

TA 101051

18-6. REAR WINCH DRIVE CHAIN REMOVAL, REPLACEMENT, AND ADJUSTMENT
(TRUCK M764).

TOOLS: No special tools required

SUPPLIES: Cotter pin (2)

PERSONNEL: Two

EQUIPMENT CONDITION: Truck parked, engine off, handbrake set.

a. Removal.

FRAME 1

Soldier A 1. Working under truck, take off four nuts (1) and screws (2).

2. Take off four nuts (3) and screws (4).

Soldiers 3. Take out earth boring machine propeller shaft (5).

A and B

GO TO FRAME 2

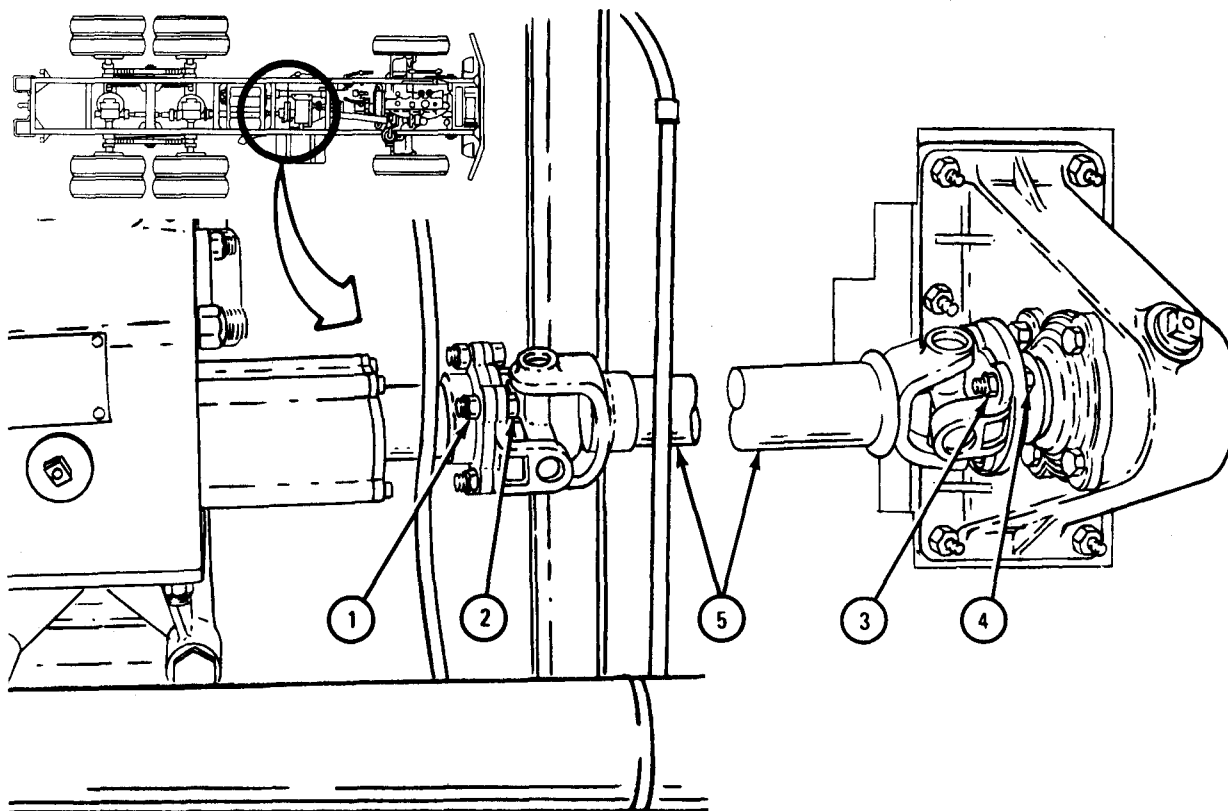

TA 101841

FRAME 2

- Soldier A 1. Take off four nuts (1) and screws (2).
2. Take off four nuts (3) and screws (4).
Soldiers A and B 3. Take out power divider propeller shaft (5).
GO TO FRAME 3

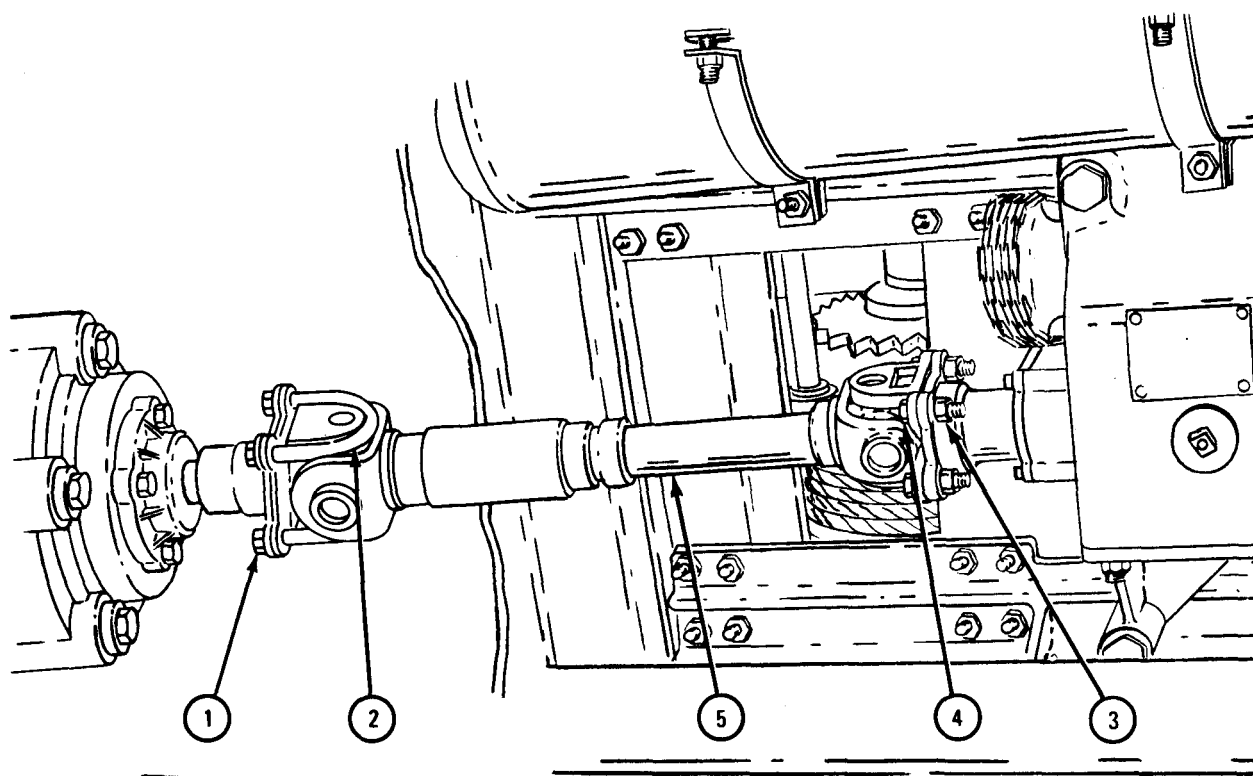

TA 101842

FRAME 3

- Soldier A
1. Take out cotter pin (1) and throw it away.
 2. Take out clevis pin (2).

GO TO FRAME 4

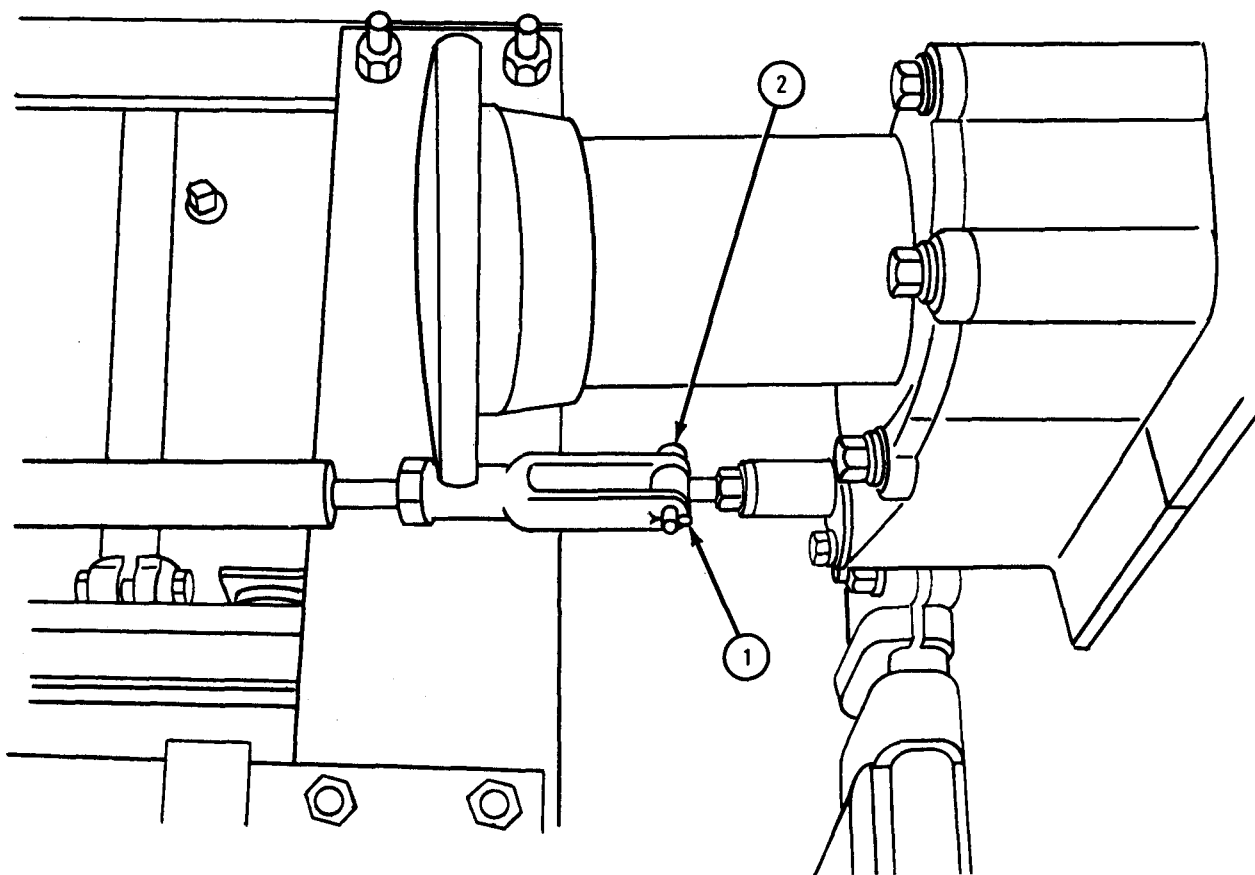

TA 101843

FRAME 4

- Soldier B
1. Takeout bushing (1) and vent (2).
 2. Loosen locknut (3) and adjusting bolt (4).
 3. Take out four screws and washers (5).
 4. Take off idler pulley and bracket assembly (6).

GO TO FRAME 5

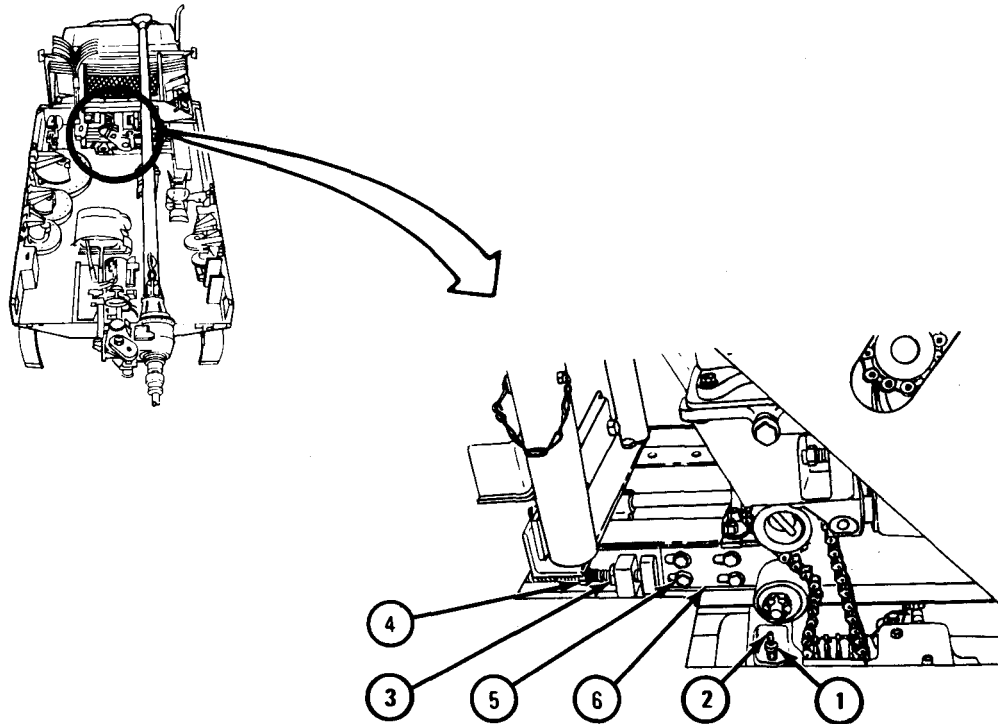

TA 101844

FRAME 5

- Soldier A 1. Takeout cotter pin (1) and throw it away.
2. Take off nut (2).
- Soldier B 3. Place transmission lift under truck to support power divider (3).
- Soldier A 4. Take out four screws and washers (4).
- GO TO FRAME 6

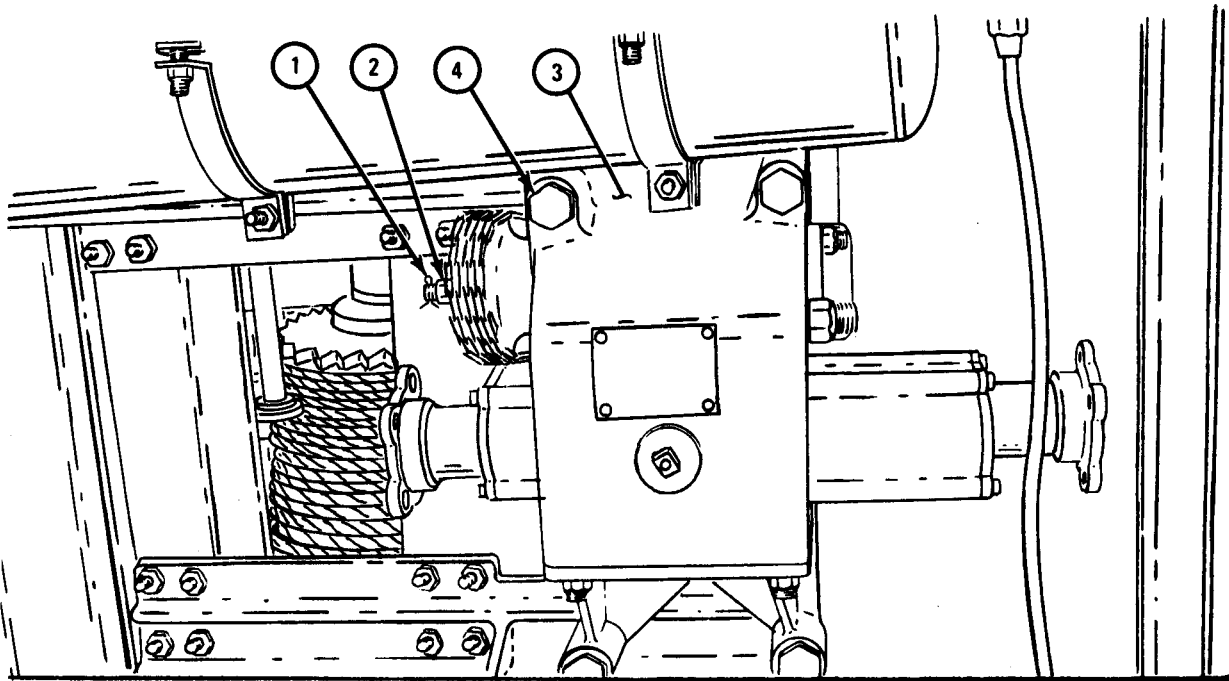

TA 101845

FRAME 6

1. Push power divider (1) towards rear of truck.
2. Take off drive sprocket (2).
3. Take out key (3).

GO TO FRAME 7

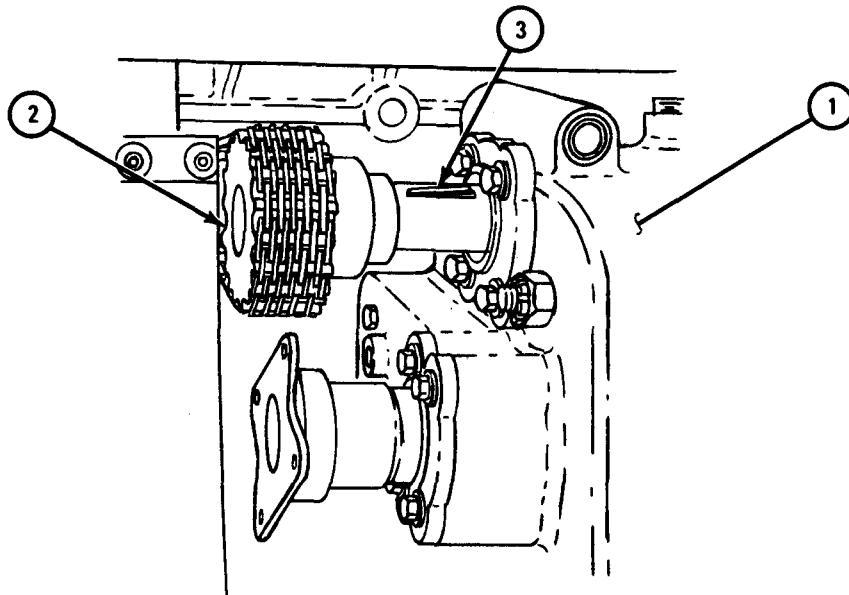

TA 101846

FRAME 7

Soldier B 1. Take off drive chain (1).
END OF TASK

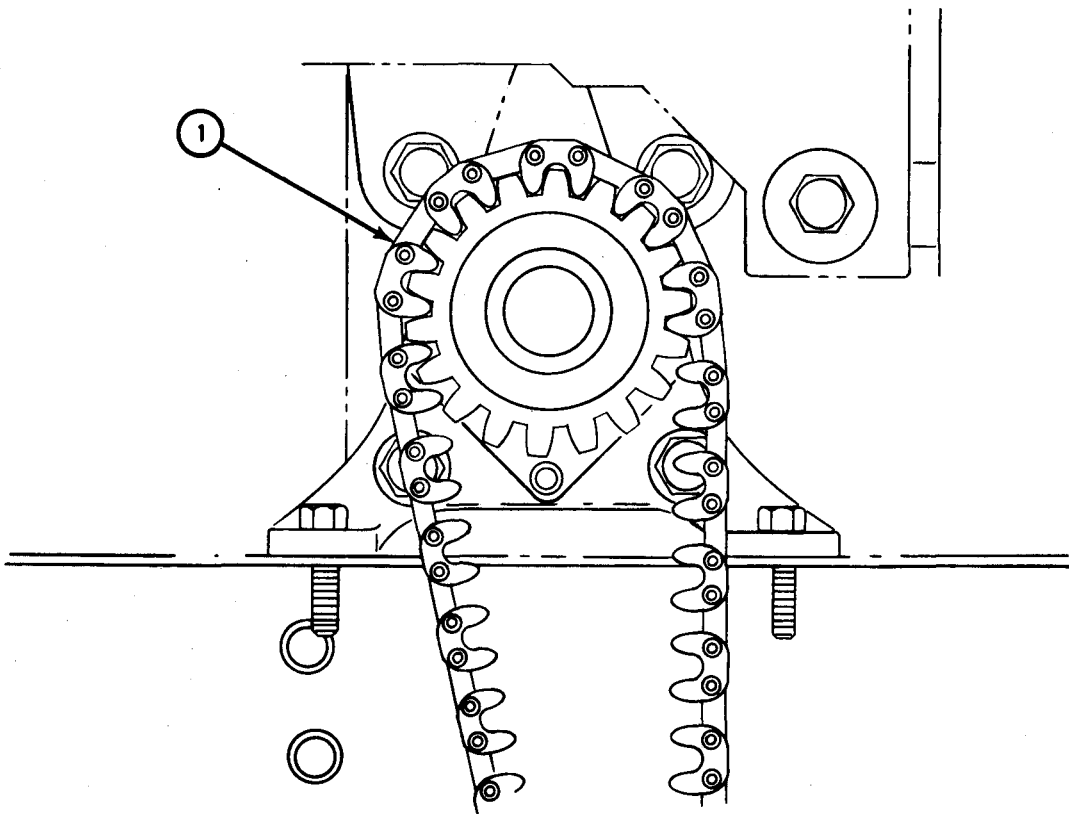

TA 101847

b. Replacement.

FRAME 1

Soldier A 1. Put on drive chain (1).
GO TO FRAME 2

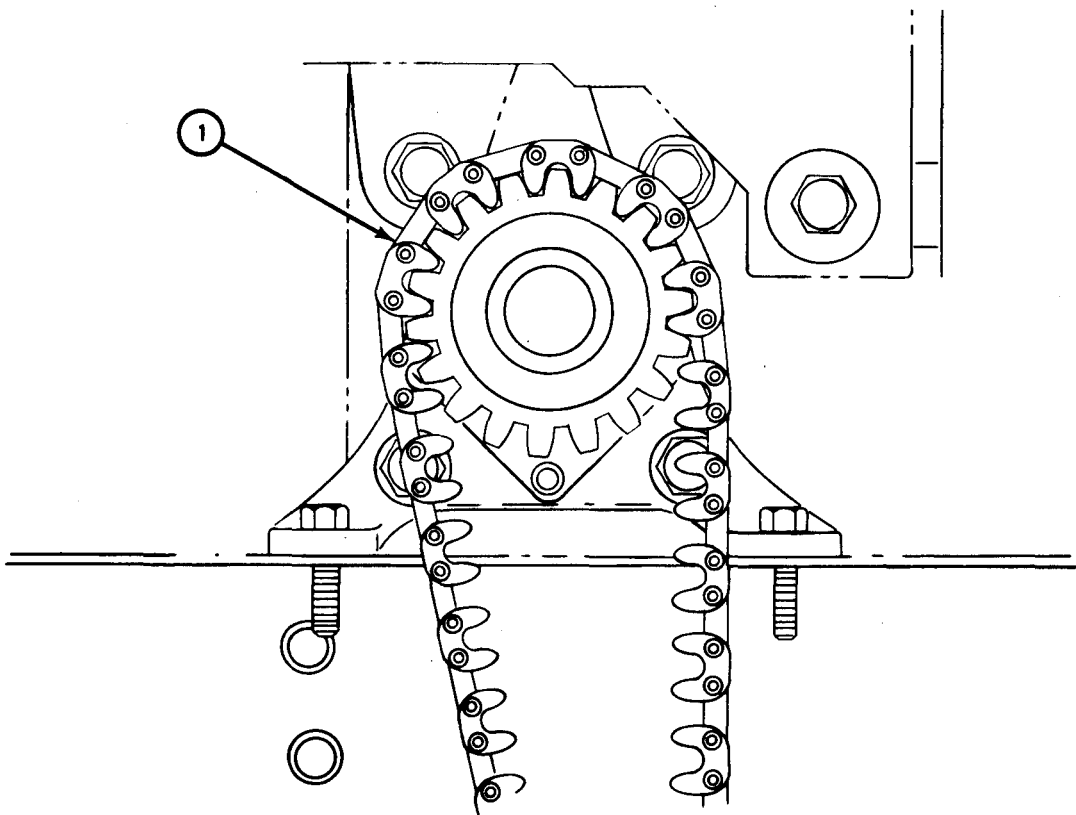

TA 101847

FRAME 2

- Soldier B
1. Working under truck, put in key (1) and turn shaft (2) until key faces up.
 2. Put in sprocket (3).
 3. Put sprocket (3) on shaft (2) with keyway in sprocket aligned with key (1).
 4. Move power divider (4) toward front of truck until holes (5) are aligned.

GO TO FRAME 3

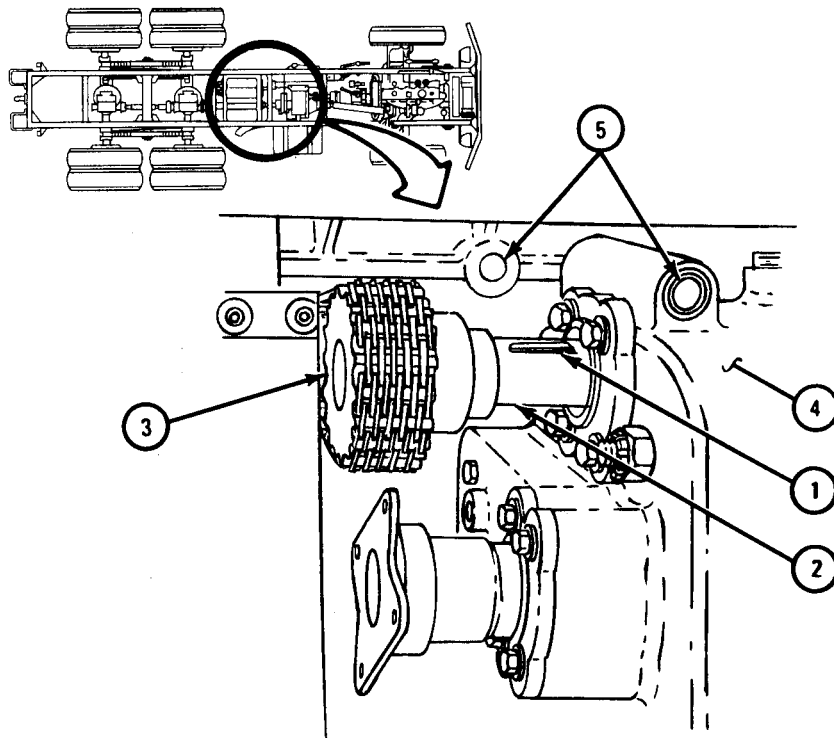

TA 101848

FRAME 3

- Soldier B 1. Put in four screws with lockwashers (1).
- Soldier A 2. Take transmission lift out from under power divider (2).
- Soldier B 3. Put on nut (3) and put in cotter pin (4).
- GO TO FRAME 4

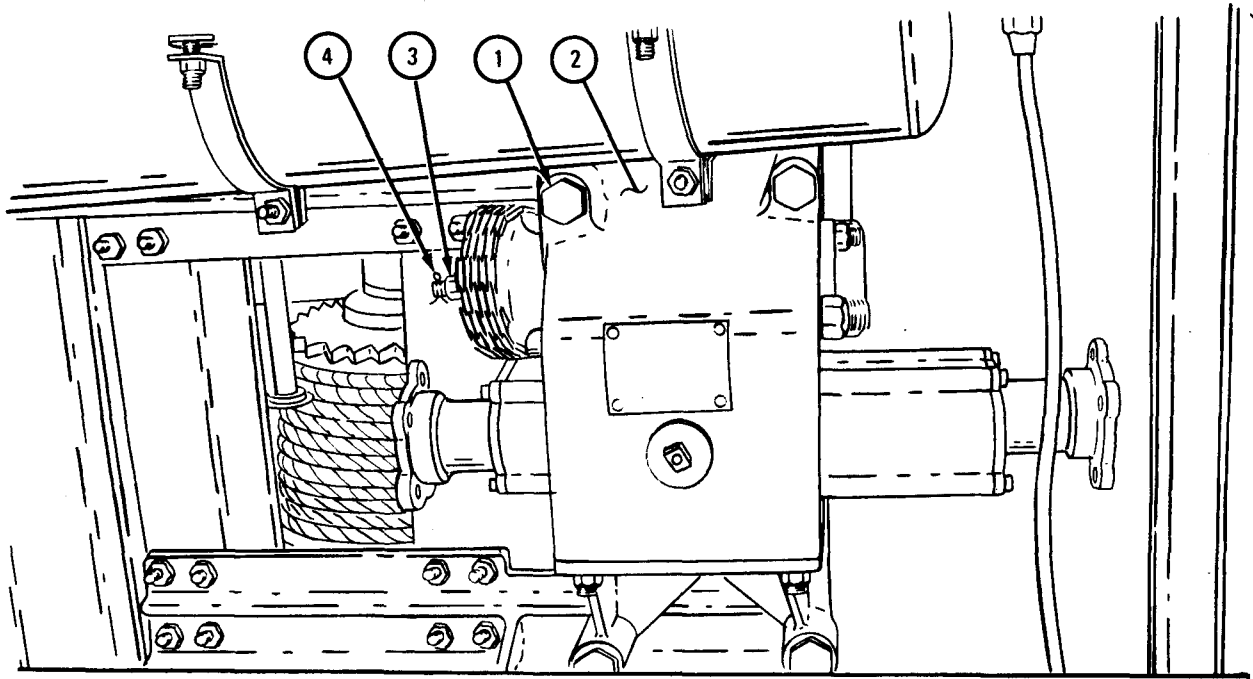

TA 101849

FRAME 4

- Soldier A
1. Align holes in idler pulley bracket assembly (1) with screw holes in frame (2).
 2. Put in and hand tighten four screws with washers (3).
 3. Put in vent and bushing (4).

GO TO FRAME 5

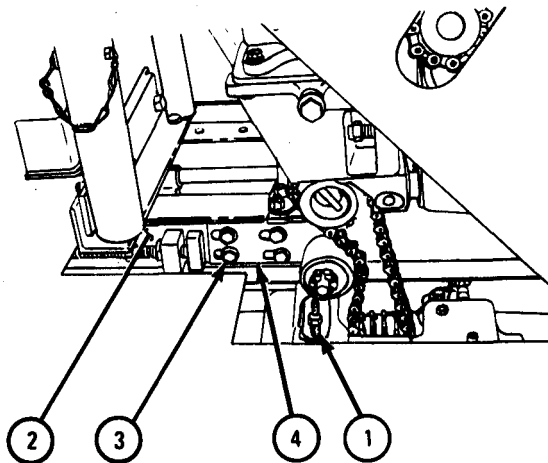

TA 101850

FRAME 5

- Soldier B
1. Put in clevis pin (1).
 2. Put in cotter pin (2).

GO TO FRAME 6

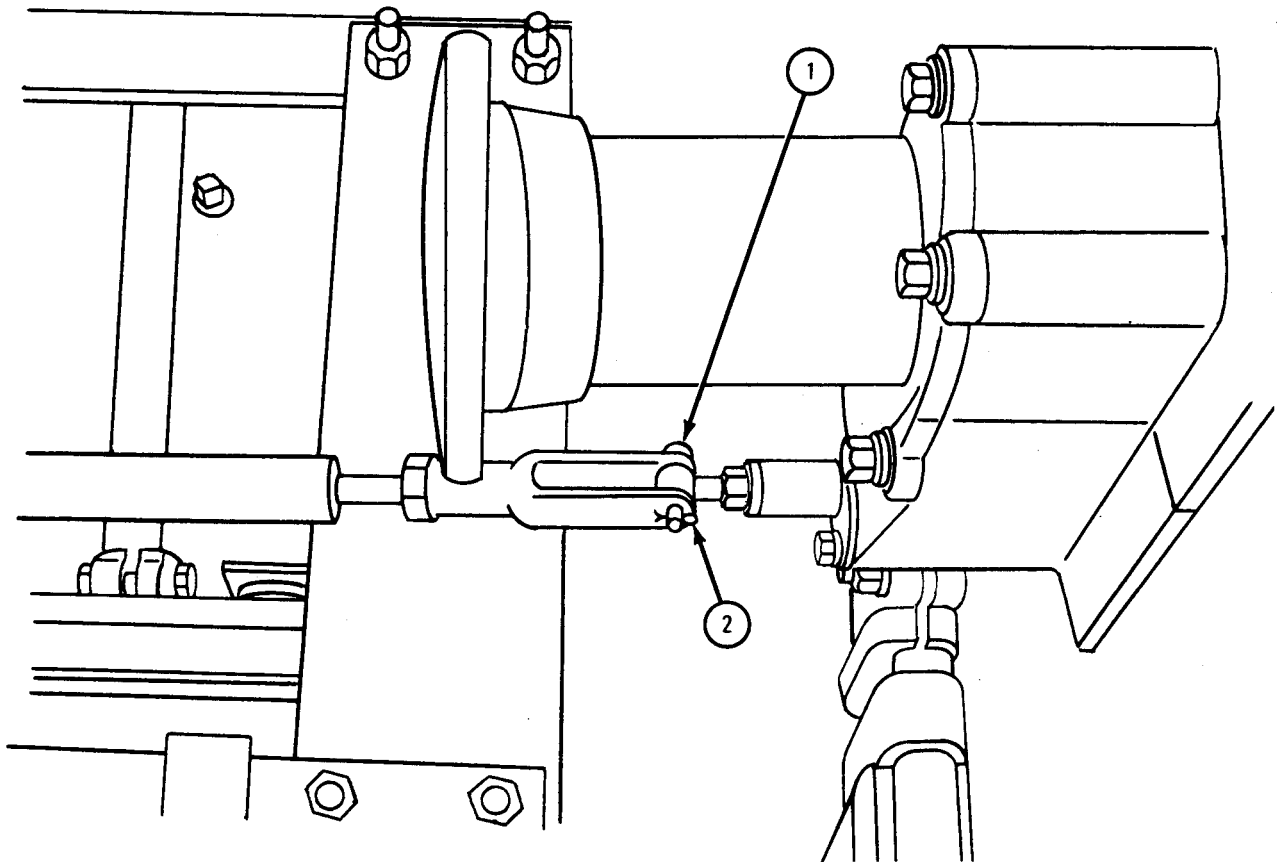

TA 101851

FRAME 6

- Soldiers A and B 1. Align screw holes in power divider propeller shaft (1) with screw holes in power divider companion flange (2).
- Soldier A 2. Put in four screws (3).
3. Put on four nuts (4).
- Soldiers A and B 4. Put two U-bolts (5) on bearing cups (6).
- Soldier B 5. Put U-bolts (5) into holes in transmission transfer power takeoff companion flange (7).
6. Put four nuts (8) on U-bolts (5).

GO TO FRAME 7

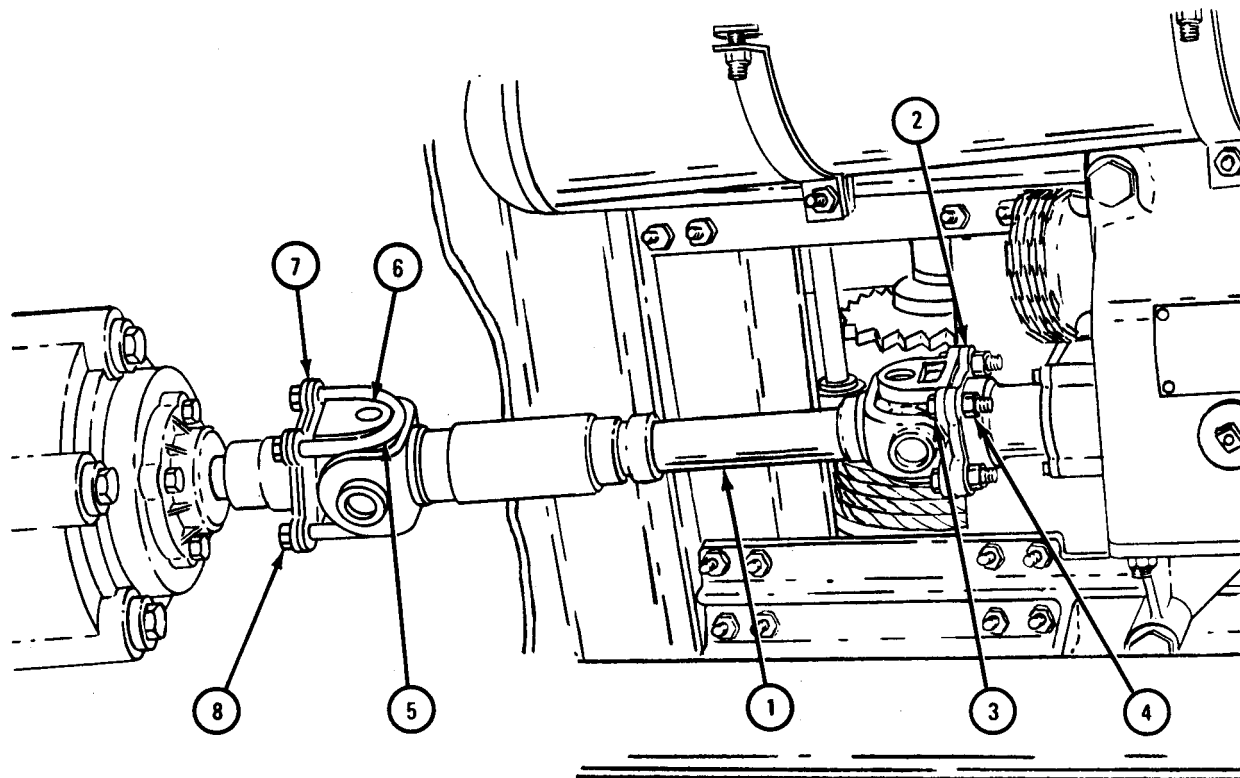

TA 101852

FRAME 7

- | | |
|---------------------|--|
| Soldiers
A and B | 1. Align screw holes in earth boring machine propeller shaft (1) with screw holes in power divider companion flange (2). |
| Soldier A | 2. Put in two screws (3).
3. Put on two nuts (4). |
| Soldiers
A and B | 4. Align screw holes in earth boring machine propeller shaft (1) with screw holes in main drive idler gear companion flange (5). |
| Soldier B | 5. Put in four screws (6).
6. Put on four nuts (7). |

END OF TASK

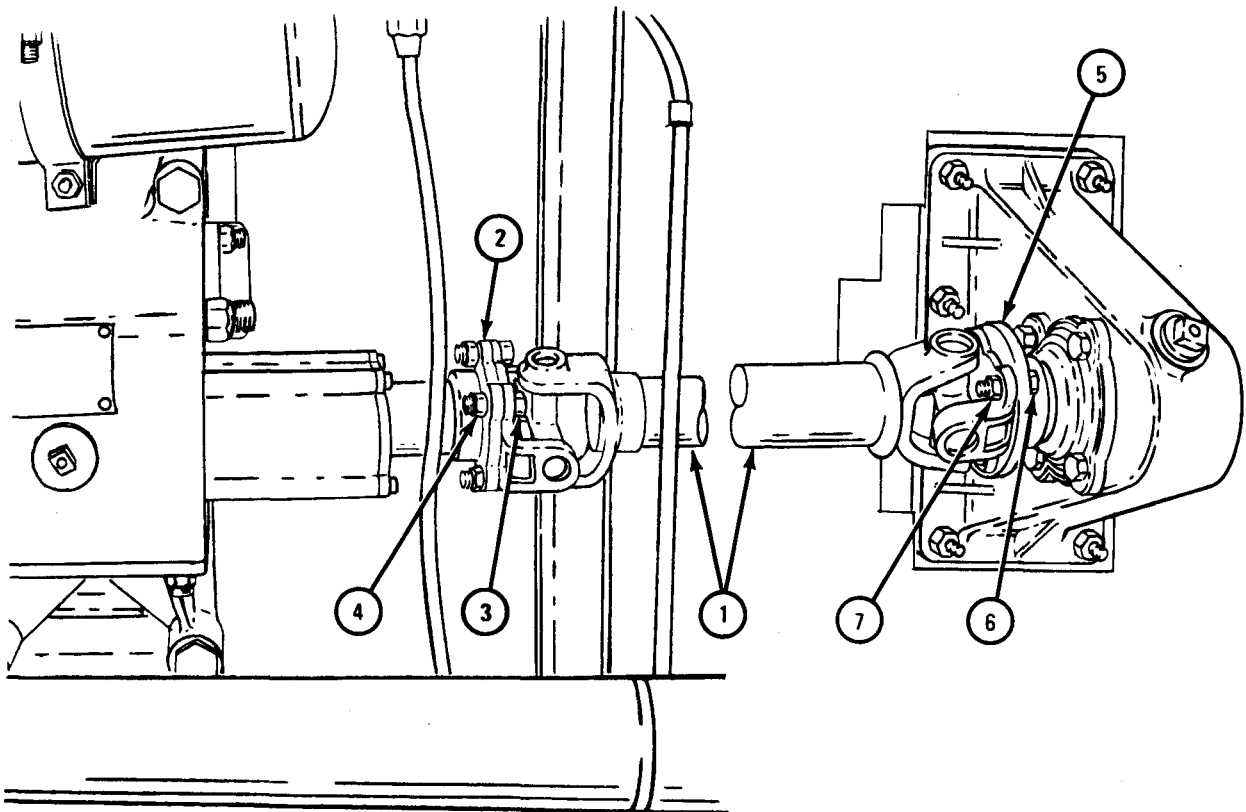

TA 101853

c. Adjustment.

FRAME 1

- Soldier A
1. Tighten screw (1) until all slack is out of chain (2).
 2. Tighten four screws (3) and check that there is no slack in chain (2). If slack is found in chain, tighten screw (1).
 3. Tighten locknut (4).

END OF TASK

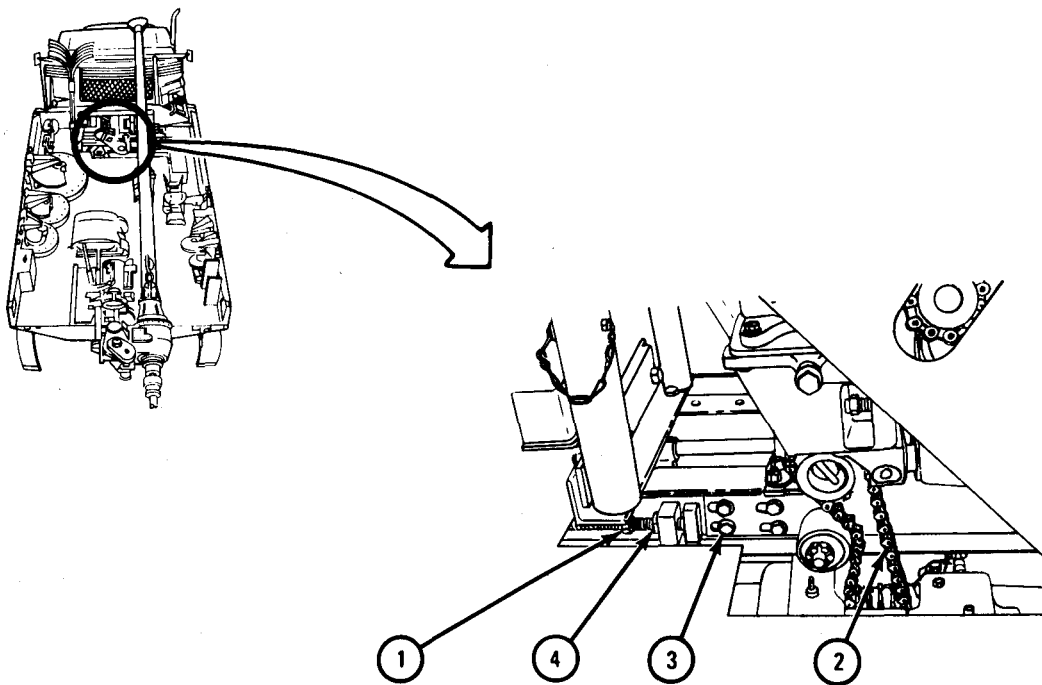

TA 101854

18-7. HYDRAULIC HOIST REMOVAL, REPAIR, AND REPLACEMENT (TRUCK M342A2).

TOOLS: No special tools required

SUPPLIES: Solvent, dry cleaning, type II (SD-2), Fed. Spec P-D-680
Artillery and automotive grease, type GAA, MIL-G-10924

PERSONNEL: Two

EQUIPMENT CONDITION: Truck parked, engine off, handbrake set.

a. Preliminary Procedure. Start engine and raise dump body. Refer to TM9-2320-209-10.

b. Removal.

FRAME 1

1. Take out lubrication fitting (1).
2. Take out screw (2) and nut (3).
3. Place wood block (4) under ends of two hoist cylinders (5) as shown.
4. Drive out pin (6).
5. Do steps 1, 2, and 4 again for other side of dump body.
6. Start engine and place dump body control in down position to pull back hoist assembly (7). Refer to TM 9-2320-209-10.
7. Slide off roller arm assemblies (8 and 9).

GO TO FRAME 2

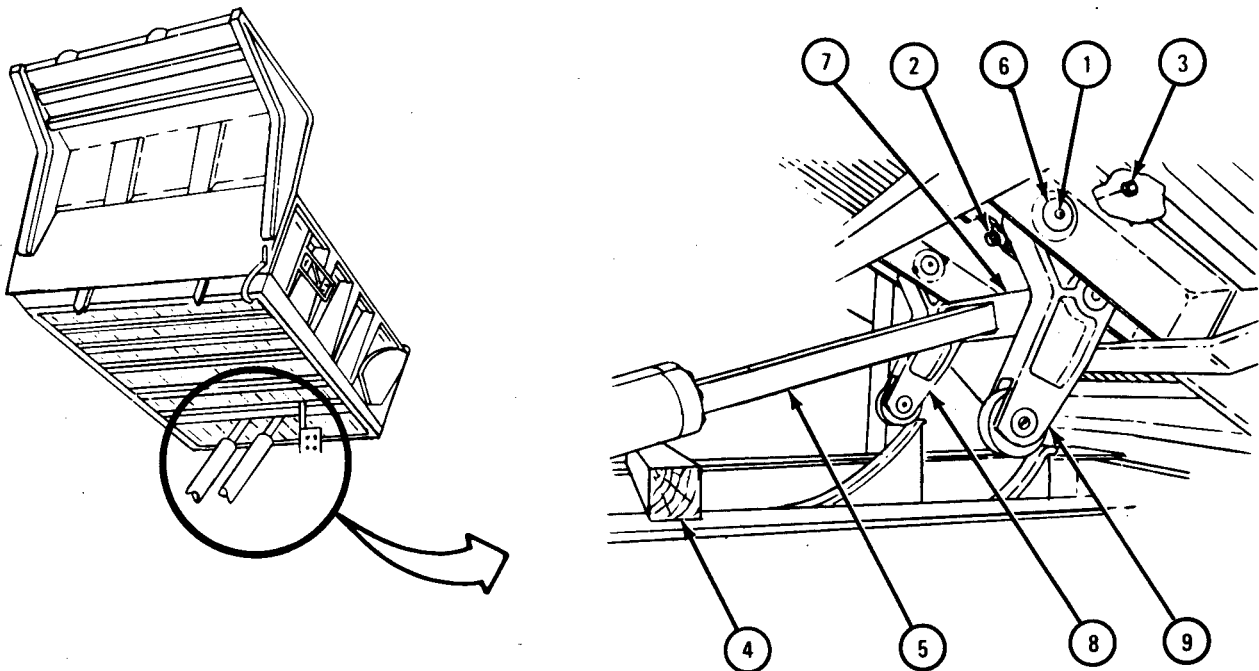

TA 105269

FRAME 2

1. Take out four screws (1). Take off two retainers (2 and 3) from crossrod (4).

Soldiers A and B 2. Take out crossrods (4) from ends of two cylinders (5).

GO TO FRAME 3

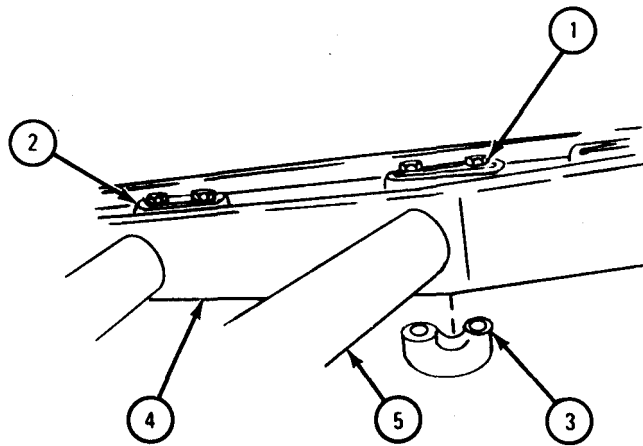

TA 105270

FRAME 3

1. Remove hydraulic hoist control linkage. Refer to TM 9-2320-209-20.
2. Take off bolt (1) and nut and capscrew (2) from valve shaft lever (3).
3. Take off three screws and lockwashers (4).
4. Take off control box (5).

END OF TASK

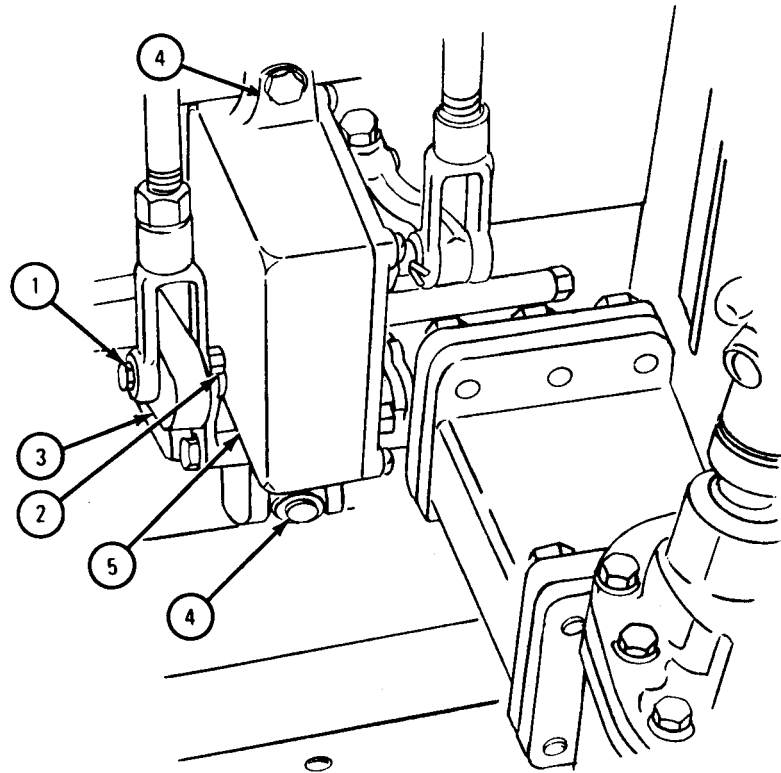

TA 088358

c. Disassembly.

FRAME 1

1. Unscrew screw (1) three turns and pull off lever (2).
2. Take off nut (3), lockwasher (4), bolt (5), and two levers (6).
3. Unscrew screw (7) three turns and pull off lever (8).
4. Take off four machine keys (9).

GO TO FRAME 2

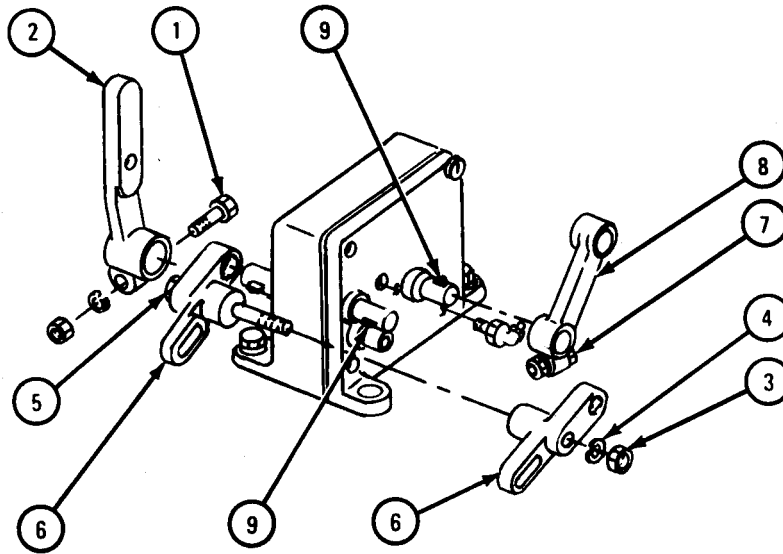

TA 088359

FRAME 2

1. Take off lubrication fitting (1).
2. Take off four screws (2) with washers (3).
3. Take cover (4) off housing (5).
4. Take off and throw away gasket (6).

GO TO FRAME 3

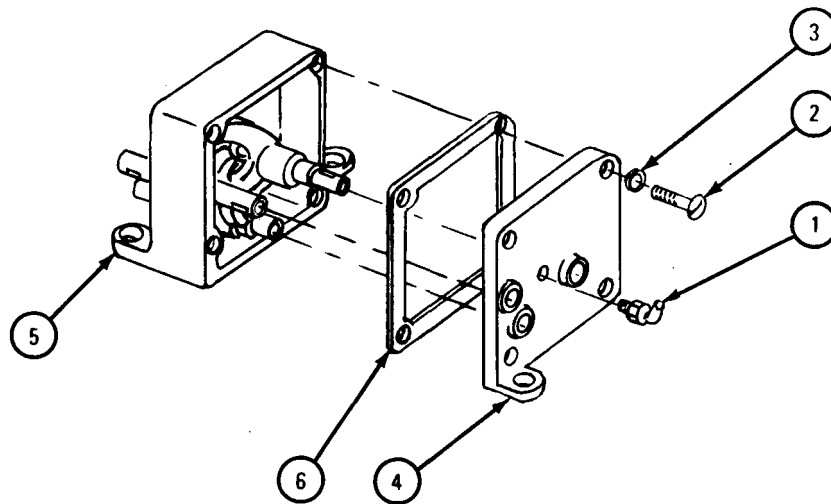

TA 088360

FRAME 3

1. Take out valve lever cam assembly (1).
2. Take out power takeoff lever cam assembly (2).
3. Take out cam-actuating lever assembly (3).

NOTE

Before disassembly, scratch aligning marks on valve lever shaft (5) and cam (1) at a point on centerline of keyways.

4. Take off two rollers (4).
5. Press valve lever shaft (5) and power takeoff lever shaft (6) out of cam assemblies (1 and 2).

GO TO FRAME 4

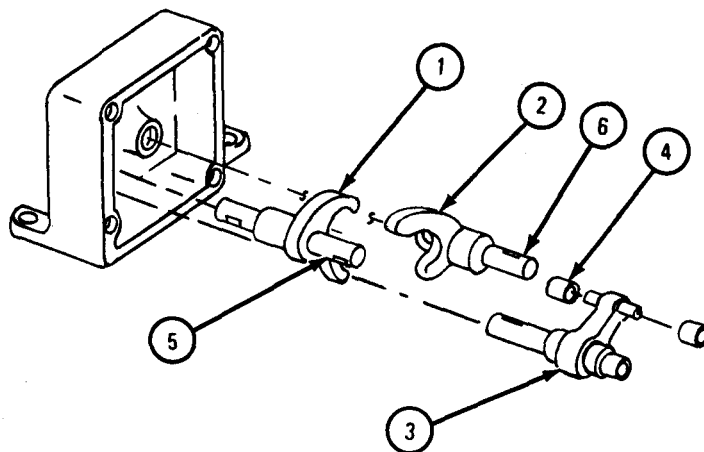

TA 088361

FRAME 4

NOTE

This task is the same for left and right crosshead roller arms. This task is shown for the left crosshead roller arm.

1. Take out two lubrication fillings (1).
2. Take out two pins (2).
3. Take out roller arm roller (3).
4. Take roller arm pin (4) out of roller arm roller (3).
5. Press out two sleeve bearings (5).

END OF TASK

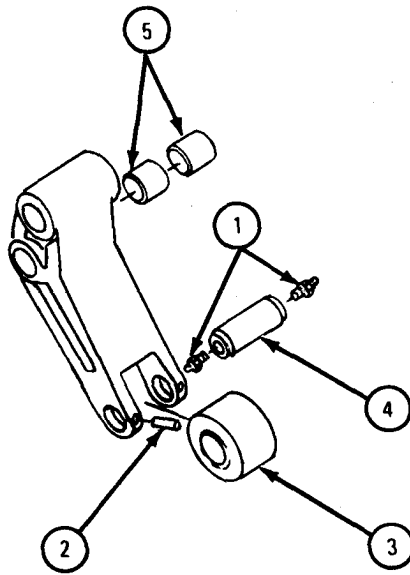

TA 088363

d. Cleaning. There are no special cleaning procedures needed. Refer to cleaning procedures given in Part 1, para 1-3.

NOTE

Clean all parts before inspection and after repair.

e. Inspection and Repair.

FRAME 1

1. Check that crosshead (1) and upper and lower lock retainers (2) have no cracks or damage. Fix cracks by welding. Refer to TM 9-237. If parts are damaged beyond repair, get new ones.
2. Check threaded holes (3) in ends of crosshead (1) and threads on retainer screws (4). Retap or rethread damaged threading. If parts are damaged beyond repair, get new ones.

GO TO FRAME 2

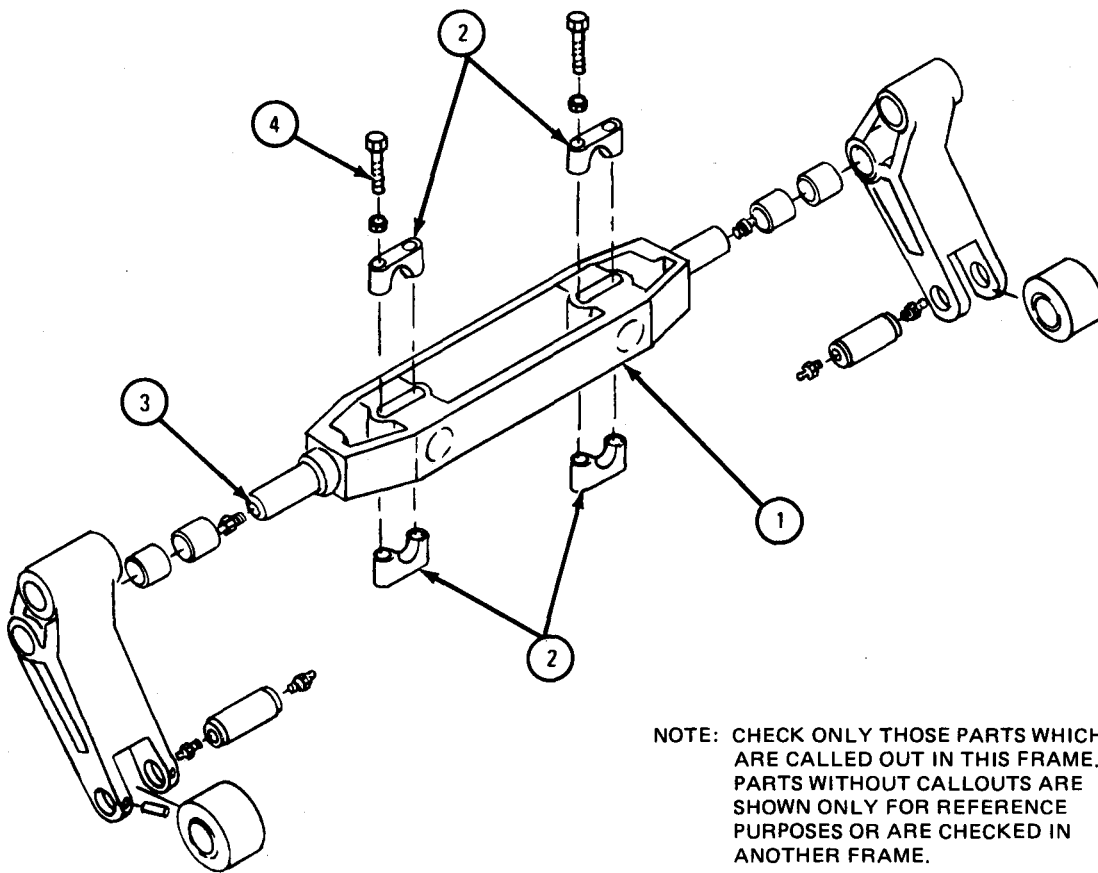

NOTE: CHECK ONLY THOSE PARTS WHICH ARE CALLED OUT IN THIS FRAME. PARTS WITHOUT CALLOUTS ARE SHOWN ONLY FOR REFERENCE PURPOSES OR ARE CHECKED IN ANOTHER FRAME.

TA 088364

FRAME 2

1. Check that roller arm rollers (1) and roller arm pins (2) have no cracks, uneven wear or other damage. If parts are damaged, get new ones.
2. Check that roller arms (3) have no cracks or damage. Fix cracks by welding. Refer to TM 9-237. If parts are damaged beyond repair, get new ones.
3. Check that roller arm bushing-type bearings (4) have no wear or damage. If bearings are worn or damaged, get new ones.
4. Check that fittings (5) and pins (6) have proper fit and are not damaged. If parts are damaged, get new ones.

GO TO FRAME 3

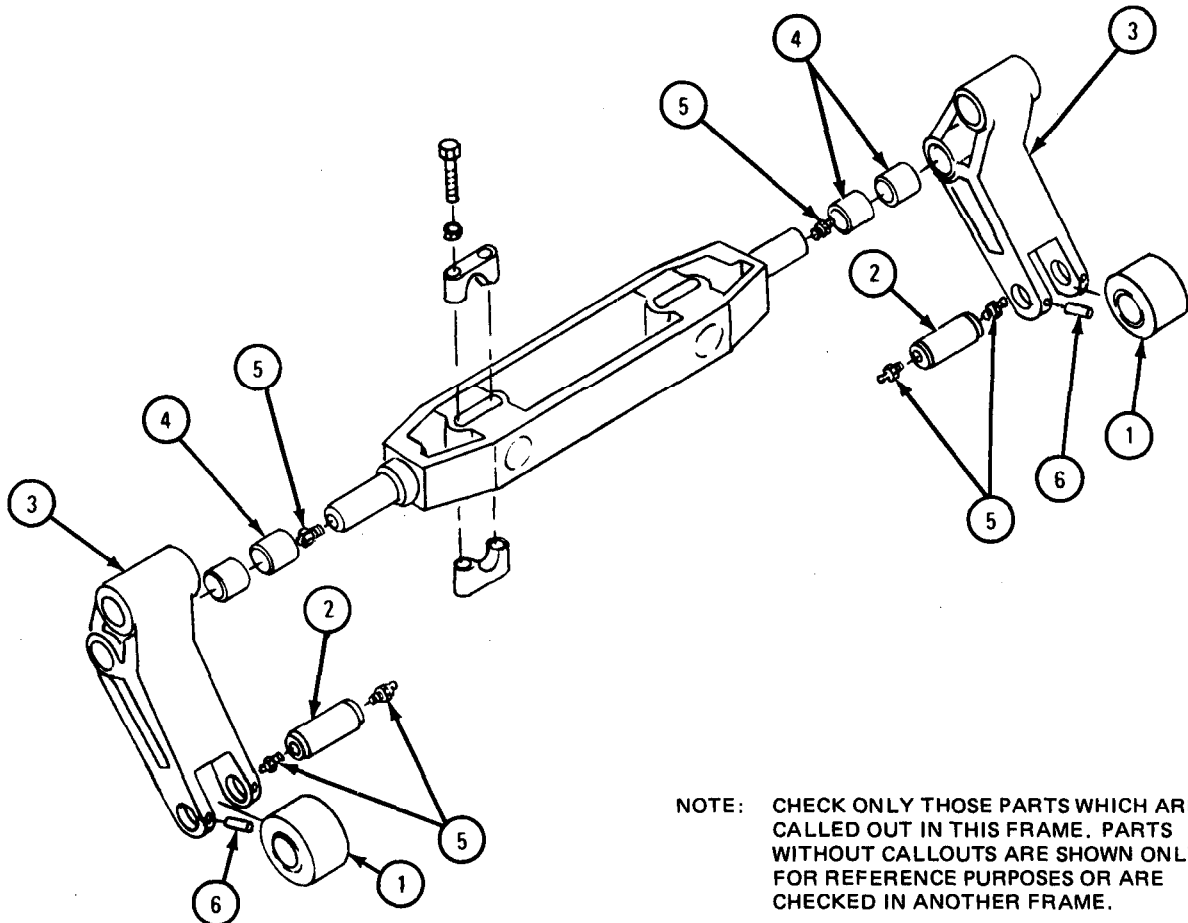

NOTE: CHECK ONLY THOSE PARTS WHICH ARE CALLED OUT IN THIS FRAME. PARTS WITHOUT CALLOUTS ARE SHOWN ONLY FOR REFERENCE PURPOSES OR ARE CHECKED IN ANOTHER FRAME.

TA 088365

FRAME 3

1. Check that housing (1) and cover (2) have no cracks or dents. Straighten dents. Refer to FM 43-2. Weld cracks. Refer to TM 9-237.
2. If cracks run into shaft holes, get new housing or cover (2).
3. Check that four levers (3) have no cracks or bends. Straighten bends and weld cracks. Refer to TM 9-237.
4. Check that tapped holes have no stripped threads. Fix damaged threads with a thread chaser.

GO TO FRAME 4

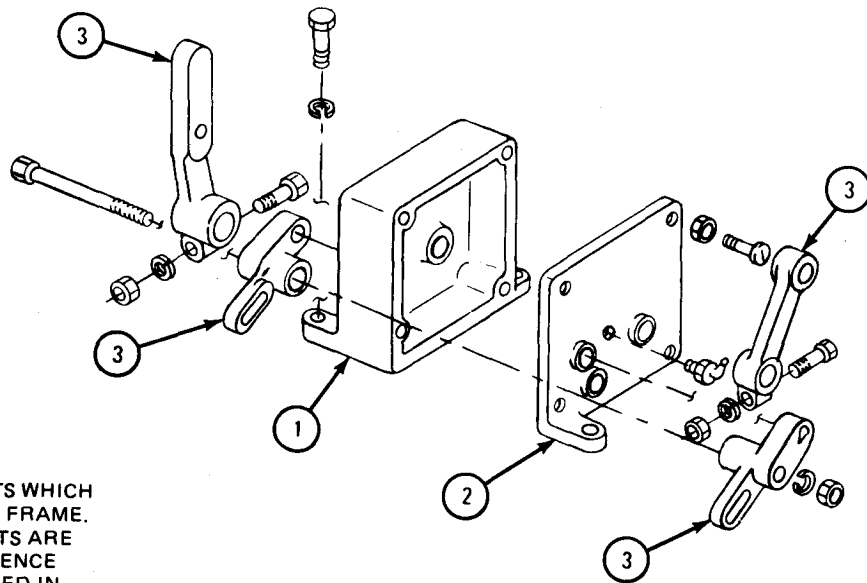

NOTE: CHECK ONLY THOSE PARTS WHICH ARE CALLED OUT IN THIS FRAME. PARTS WITHOUT CALLOUTS ARE SHOWN ONLY FOR REFERENCE PURPOSES OR ARE CHECKED IN ANOTHER FRAME.

TA 088366

FRAME 4

1. Check that cam-actuating lever (1), valve lever cam (2), and power takeoff lever cam (3) have no cracks, bends or other damage. Fix cracks by welding. Refer to TM 9-237. Straighten bent levers.
2. Check that power takeoff lever shaft (4) and valve lever shaft (5) have no cracks, nicks, burrs or tight fit. Fix cracks by welding. Refer to TM 9-237. Take off nicks and burrs.
3. Check that rollers (6) have no damage or wear.
4. If parts are worn or damaged beyond repair, get new ones.

END OF TASK

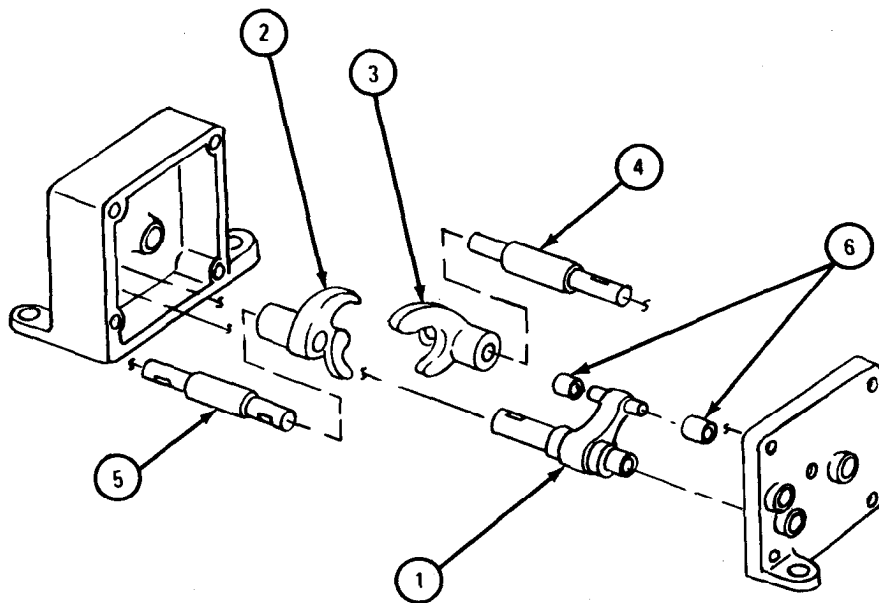

NOTE: CHECK ONLY THOSE PARTS WHICH ARE CALLED OUT IN THIS FRAME. PARTS WITHOUT CALLOUTS ARE SHOWN ONLY FOR REFERENCE PURPOSES OR ARE CHECKED IN ANOTHER FRAME.

TA 088367

f. Assembly.

FRAME 1

1. Put a light film of grease on power takeoff lever shaft (1) and cams (2).
2. With cams (2) in arbor press and aligning marks facing up, place shaft (1) in cams.
3. Press shaft (1) into cams (2) so that ends of notches on shaft are flush with hub on cams.
4. Do steps 1, 2 and 3 again for valve lever shaft and cams.

GO TO FRAME 2

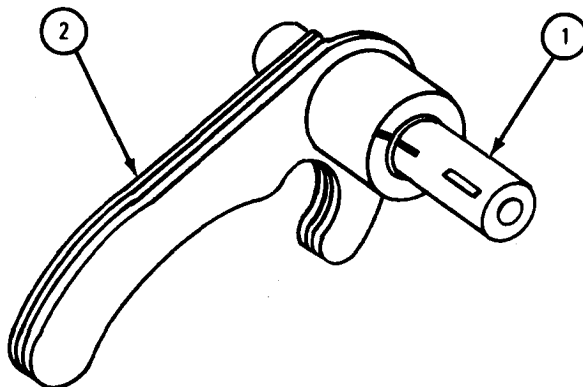

TA 088368

FRAME 2

1. Put short end of power takeoff lever shaft (1) into housing (2).
2. Put long end of cam-actuating lever assembly (3) into housing (2). Be sure shaft (1), roller (4), and lever (3) are in line.
3. Note position of keyway (5) when shaft (1), roller (4), and lever (3) are in line. Push cam actuating lever (6) all the way down while keeping roller (4) touching power takeoff lever cam (7).
4. Keyway (5) should now be 180° from where it was in step 2.

GO TO FRAME 3

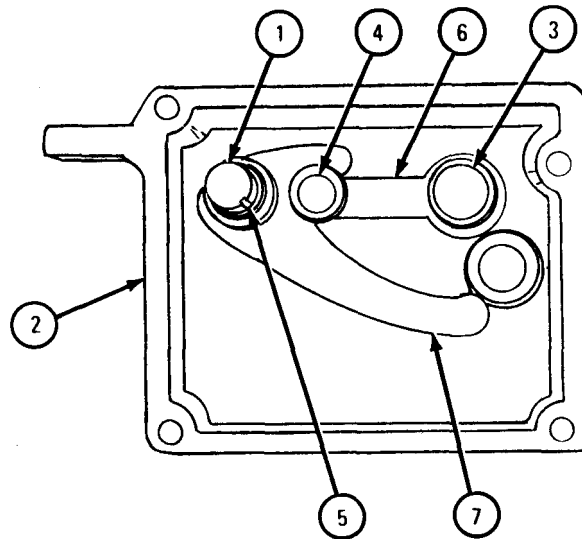

TA 088369

FRAME 3

1. Put valve lever shaft (1) into housing (2) on top of power takeoff lever cam (3). Hub of valve lever cam (4) must be against housing.
2. Move valve lever cam (4) all the way up and all the way down. Keyway (5) must move same distance above and below horizontal centerline scribed on housing (2).
3. Fill housing (2) with grease.
4. Put gasket (6) on housing (2).
5. Put on cover (7) and put in four lockwashers (8) and screws (9).
6. Put in lubrication fitting (10).

GO TO FRAME 4

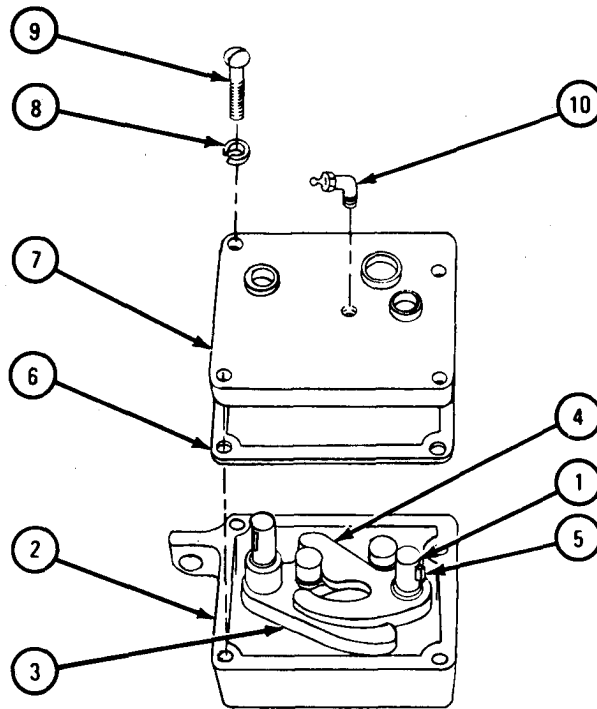

TA 088370

FRAME 4

1. Put machine key (1) in power takeoff lever shaft (2).
2. Align keyway in power takeoff shaft lever (3) with shaft (2) and put on power takeoff shaft lever.
3. Tighten screw (4).
4. Put machine key (5) in cam-actuating lever shaft (6).
5. Align cam-actuating lever (7) with shaft (6) and put on lever (7).
6. Put on lubrication fitting (8).

GO TO FRAME 5

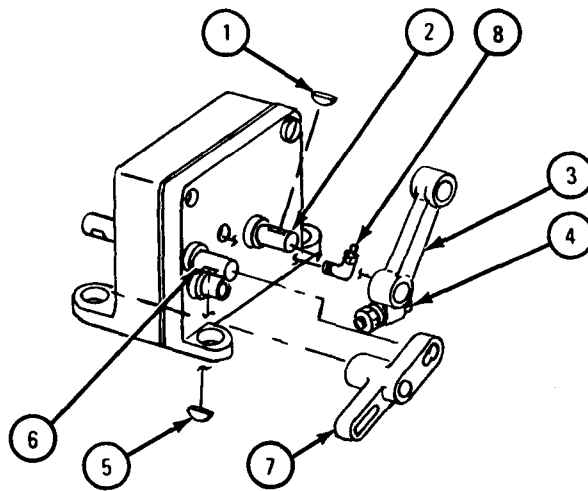

TA 088371

FRAME 5

1. Put machine key (1) in cam-actuating lever shaft (2).
2. Align cam-actuating lever (3) on shaft (2) and put on lever.
3. Put bolt (4) through both cam-actuating levers (3) and put on washer (5) and nut (6).
4. Put machine key (7) in power takeoff lever (8). Align control rod lever (9) with power takeoff lever and put on control rod lever.
5. Tighten screw (10).

GO TO FRAME 6

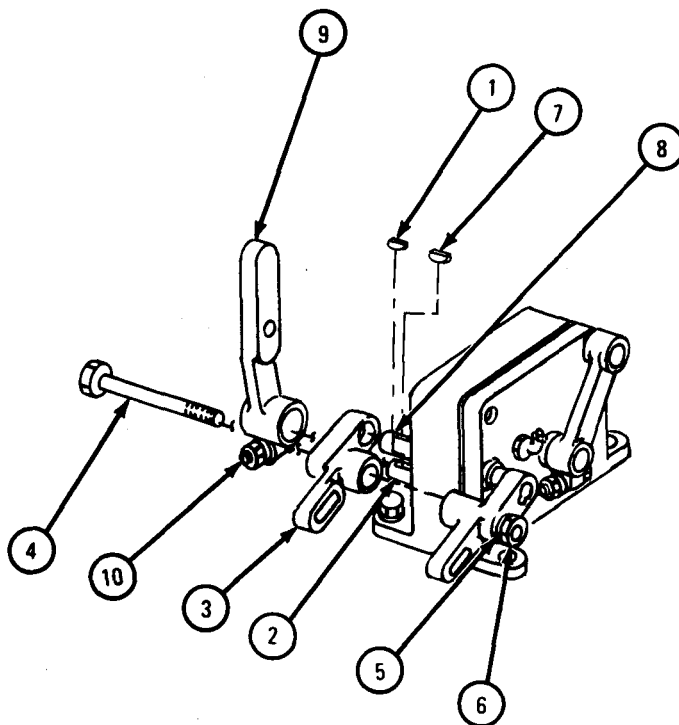

TA 088372

FRAME 6

NOTE

This task is the same for the left and right crosshead roller arms. This task is shown for the left crosshead roller arm.

1. Press in two sleeve bearings (1).
2. Put roller arm pin (2) in roller arm roller (3).
3. Put roller arm roller (3) into roller arm (4).
4. Put in two pins (5).
5. Put in two lubrication fittings (6).

END OF TASK

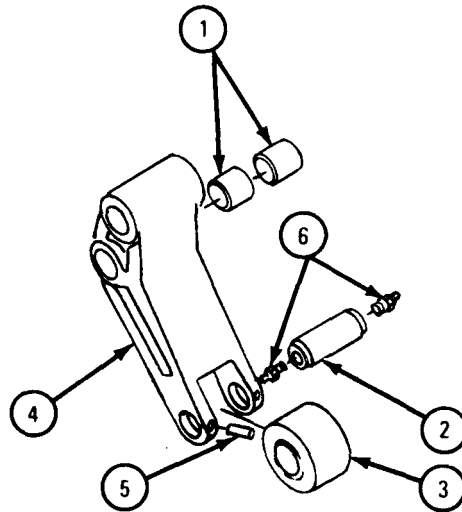

TA 088373

g. Replacement.

FRAME 1

1. Put control box (1) on frame (2).
2. Put three screws with lockwashers (3) through control box (1) and frame (2).
3. Put control arm (4) on valve shaft lever (5).
4. Align holes in control arm (4) with hole in valve shaft lever (5) and put in bolt (6) and nut and capscrew (7).

GO TO FRAME 2

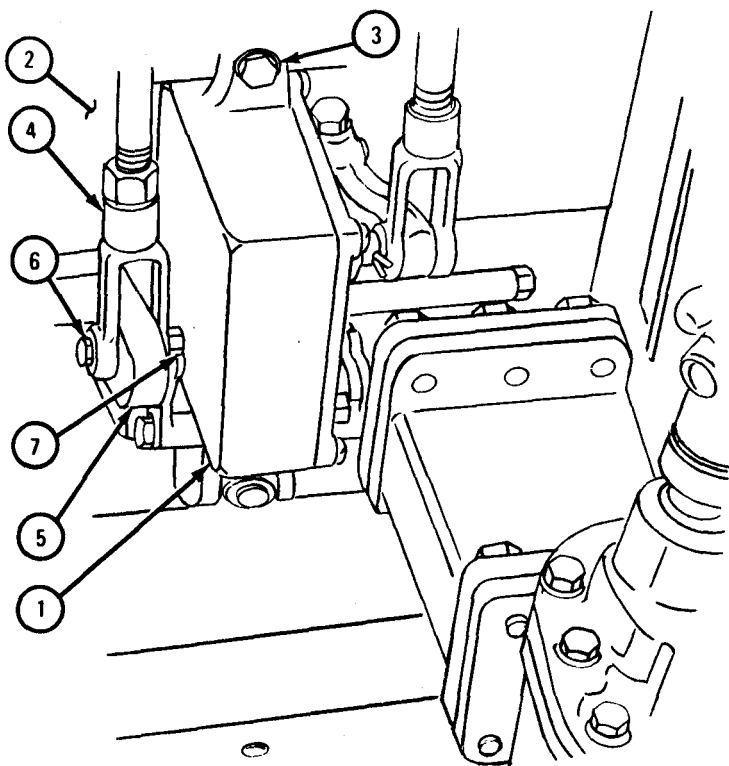

TA 088375

FRAME 2

1. Replace hydraulic hoist control linkage. Refer to TM 9-2320-209-20.
 2. Slide two roller arm assemblies (1) onto crosshead (2).
- Soldier A 3. Start engine and raise dump body to raise crosshead (2) with roller arm assemblies (1). Refer to TM 9-2320-209-10.
- Soldier B 4. Align holes in roller arm assemblies (1) with holes in dump body (3).

NOTE

A jack may be needed to finish aligning holes.

5. Drive pin (4) through dump body (3) and roller arm assemblies (1). Align screw holes in pins with screw holes in dump body.

GO TO FRAME 3

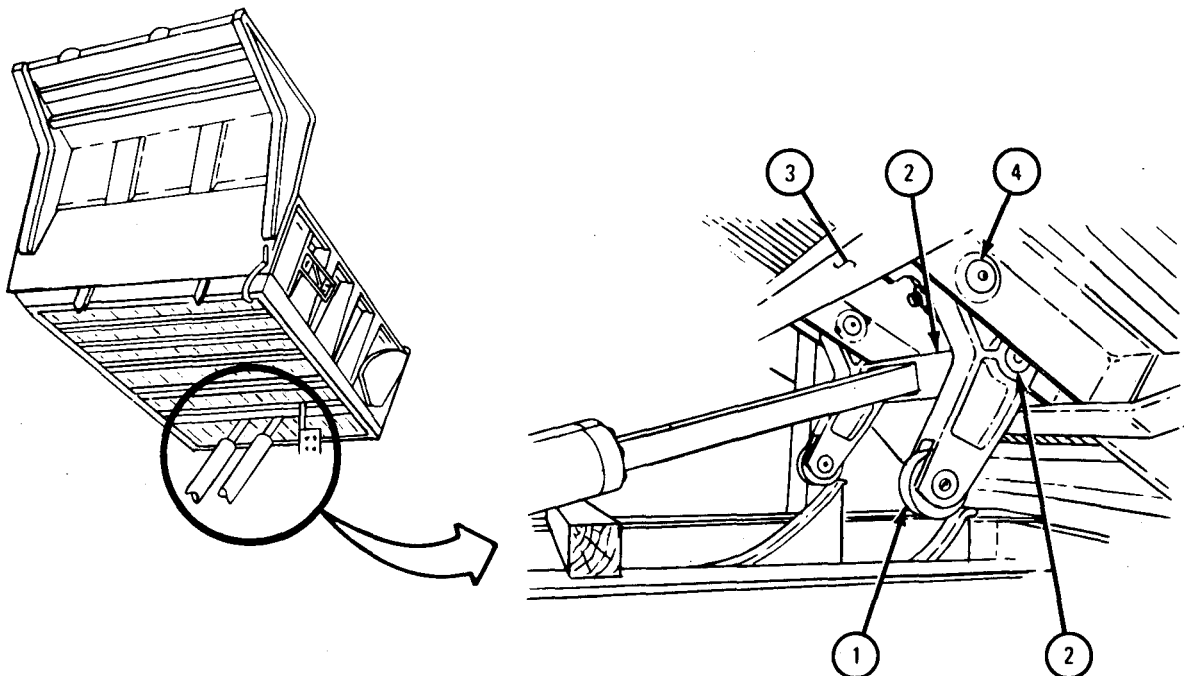

TA 105271

FRAME 3

1. Put in screw (1) and nut (2).
2. Put in lubrication fitting (3).
3. Do steps 1 and 2 again on other side.
4. Take out wood block (4).

GO TO FRAME 4

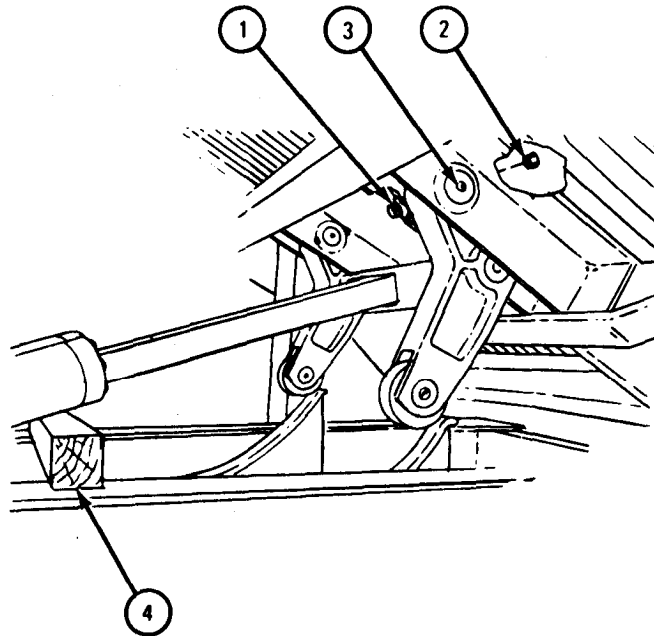

TA 105272

FRAME 4

1. Grease roller arm assemblies. Refer to LO 9-2320-209-12/1.
2. Raise dump body (1) far enough to free two hoist braces (2). Refer to TM 9-2320-209-10.
3. Swing hoist braces (2), one on each side, down to stowed position.
4. Lower dump body (1) and stop engine. Refer to TM 9-2320-209-10.

END OF TASK

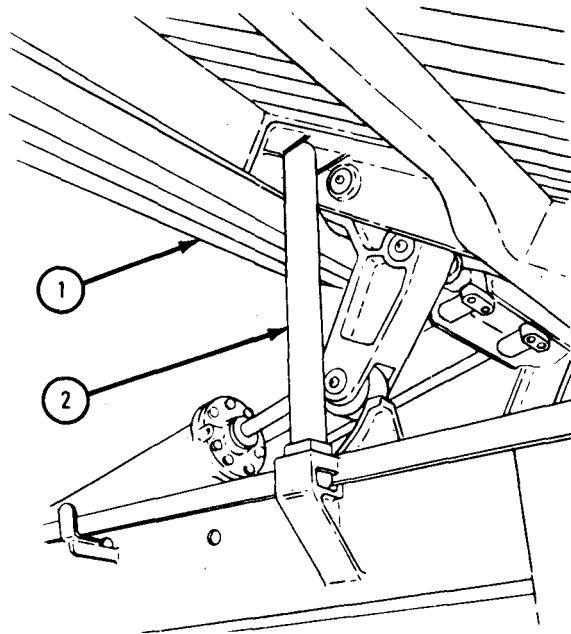

TA 105273

18-8. HYDRAULIC HOIST CYLINDER ASSEMBLY REMOVAL, REPAIR, AND REPLACEMENT (TRUCK M342A2).

NOTE

This task is the same for the left and right hoist cylinder assemblies. This task is shown for the left hoist cylinder assembly.

TOOLS: No special tools required

SUPPLIES: Retainer packing
Cylinder head preformed packing
Solvent, dry cleaning, type II (SD-2), Fed. Spec P-D-680
Lubricating oil, ICE, OE/HDO 10, MIL-L-2104
Tags

EQUIPMENT CONDITION: Truck parked, engine off, handbrake set, truck washed or steam cleaned.

WARNING

Always use safety braces when working under dump body. Movement of the control valve or leakage at the hydraulic cylinder line or hose connections can cause the body to drop to the subframe.

CAUTION

Do not use power to lower dump body to safety braces. Damage to subframe can occur.

a. Preliminary Procedures.

- (1) Raise dump body. Refer to TM 9-2320-209-10.
- (2) Lock safety braces under dump body. Refer to TM 9-2320-209-20.

b. Removal.

FRAME 1

1. Tag hoses (1) to be sure they go back in the same place.
 2. Take off hoses (1) and adapters (2) from control valve (3).
- GO TO FRAME 2

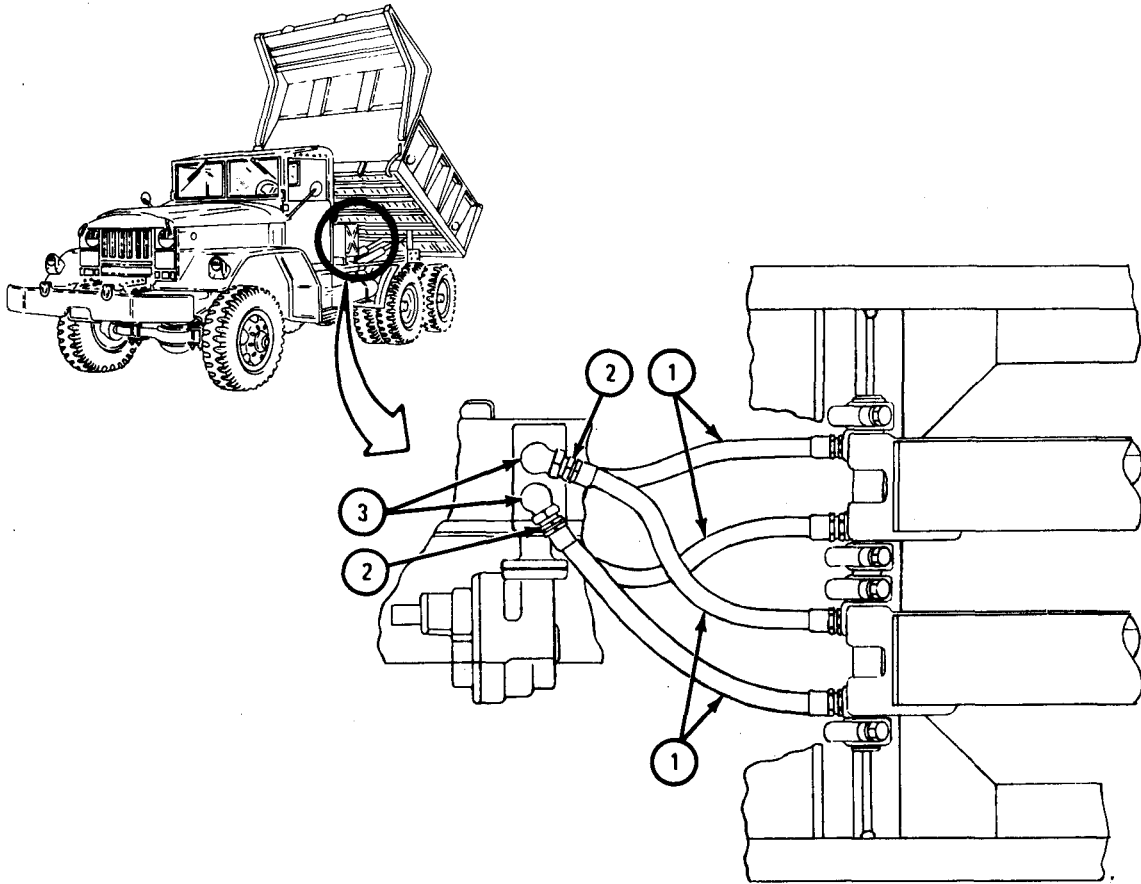

TA 084149

FRAME 2

1. Place wooden block, 4 inches x 4 inches x 4 feet, under upper end of two hoist cylinder assemblies (1).
2. Take out two screws with lockwashers (2). Hold lower retainer (3) so that it will not fall when last screw (2) is taken out. Take out upper retainer (4).
3. Take out two screws and lockwashers (5).
4. Take off two bearing caps (6).

CAUTION

Bypass tubes on outside of hoist cylinder assembly (1) are easily damaged. Be careful when lifting out hoist cylinder assembly.

- Soldier A 5. Hold hoist cylinder assembly (1).
- Soldier B 6. Using pry bar, pry bottom of hoist cylinder assembly (1) towards rear of truck.
- Soldiers A and B 7. Pull piston rod (7) out of crosshead (8) and lift hoist cylinder assembly (1) off truck.

END OF TASK

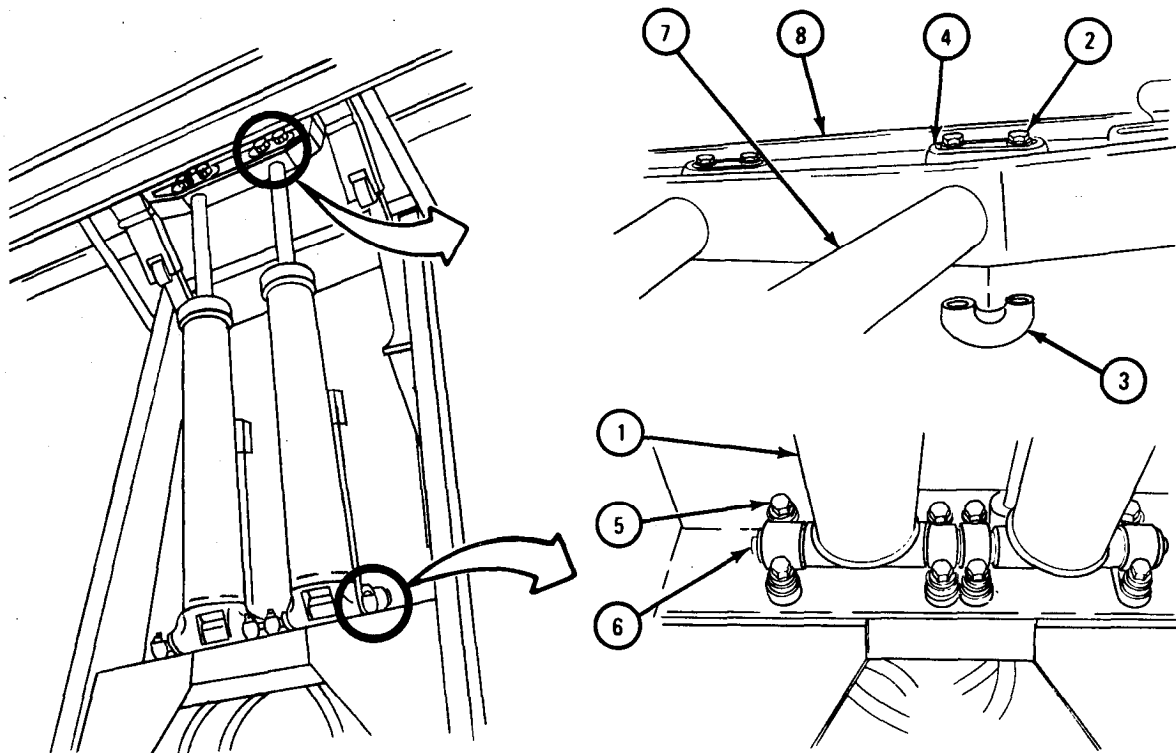

TA 084150

c. Disassemble.

FRAME 1

1. Take out three screws with washers (1).
2. Take out retainer (2) and packing (3). Throw away packing.
3. Take out 10 bolts with lockwashers (4).
4. Take off cylinder head (5) and preformed packing (6).
5. Take preformed packing (6) off cylinder head (5). Throw away preformed packing.
6. Slide piston rod assembly (7) out of tube assembly (8). Be careful not to damage inside of tube assembly.

GO TO FRAME 2

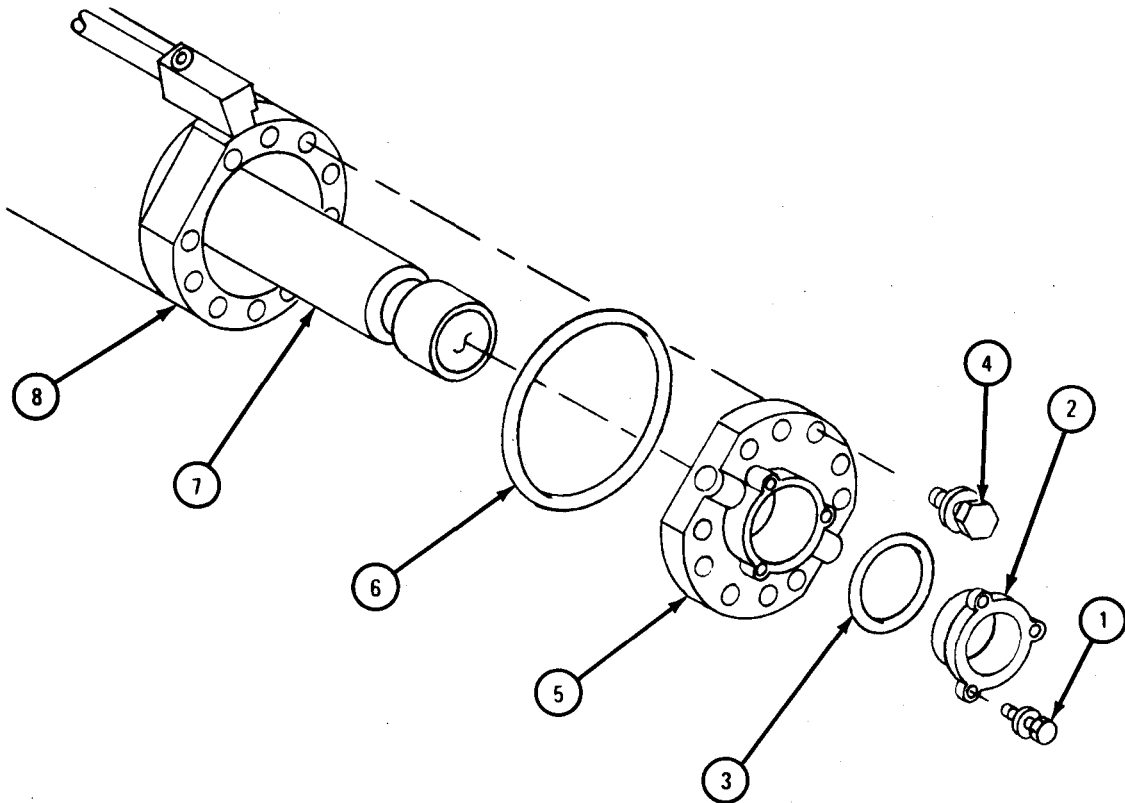

TA 084151

FRAME 2

1. Clamp piston rod (1) in vise with soft jaws.
2. Take out and throw away cotter pin (2).
3. Take off nut (3).
4. Take off piston (4).
5. Take off three piston rings (5) from piston (4).

GO TO FRAME 3

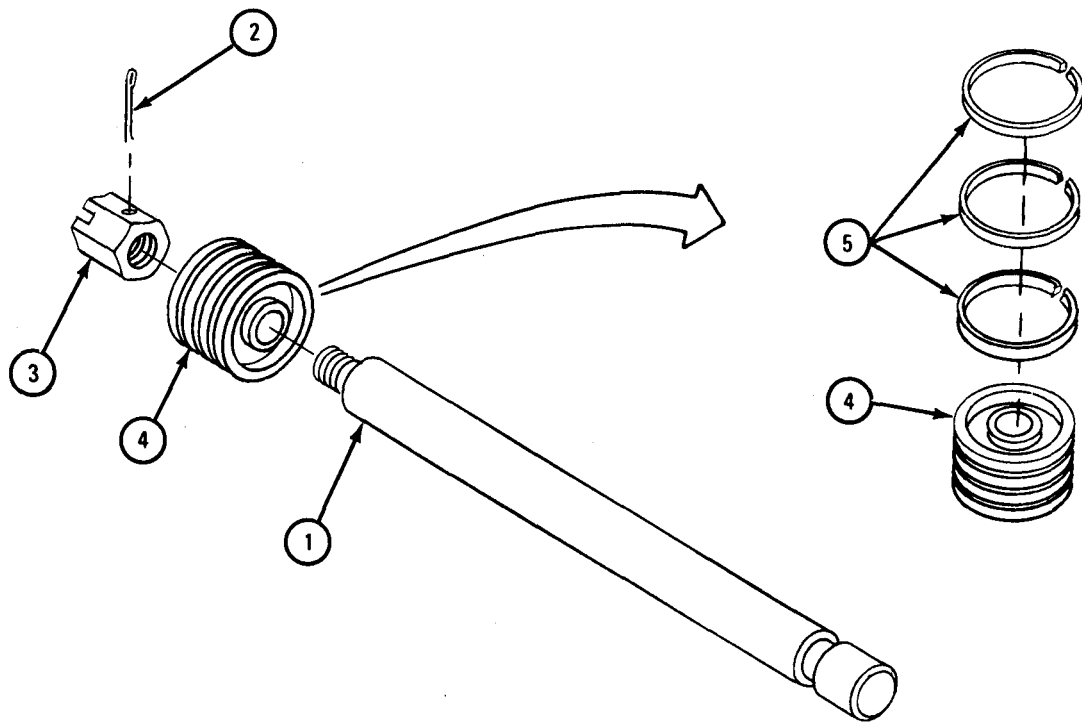

TA 084152

FRAME 3

1. Take out three plugs (1), springs (2), and check balls (3).

GO TO FRAME 4

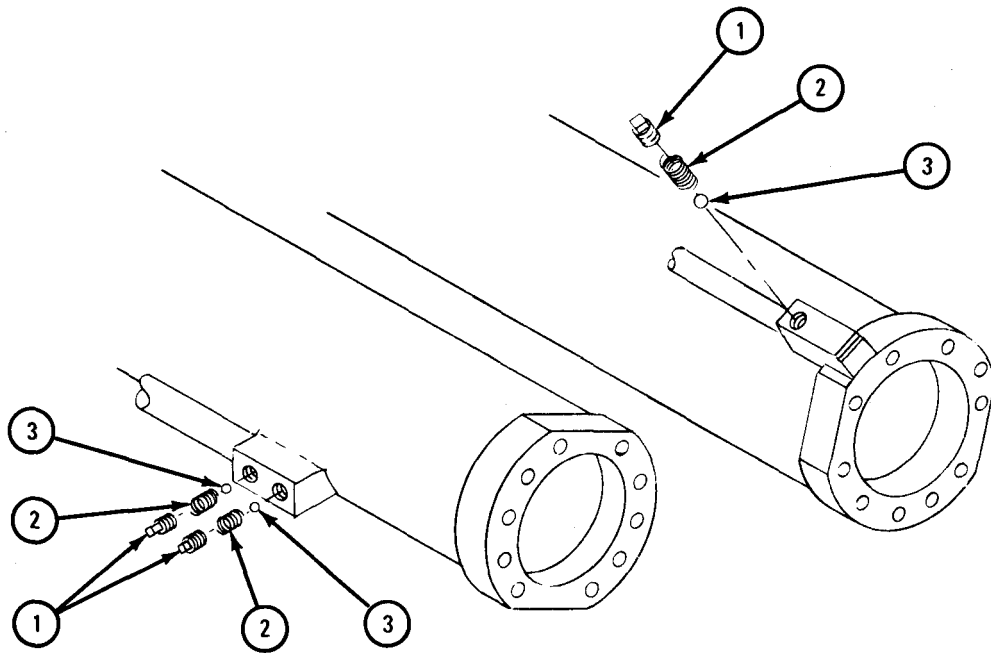

TA 084153

FRAME 4

1. Take out plug (1) and ring spacer (2).
2. Take out fluid flow plug resistor (3).
3. Take out lubrication fitting (4).
4. Take out two setscrews (5).
5. Using brass punch and ballpeen hammer, drive out pin (6).

END OF TASK

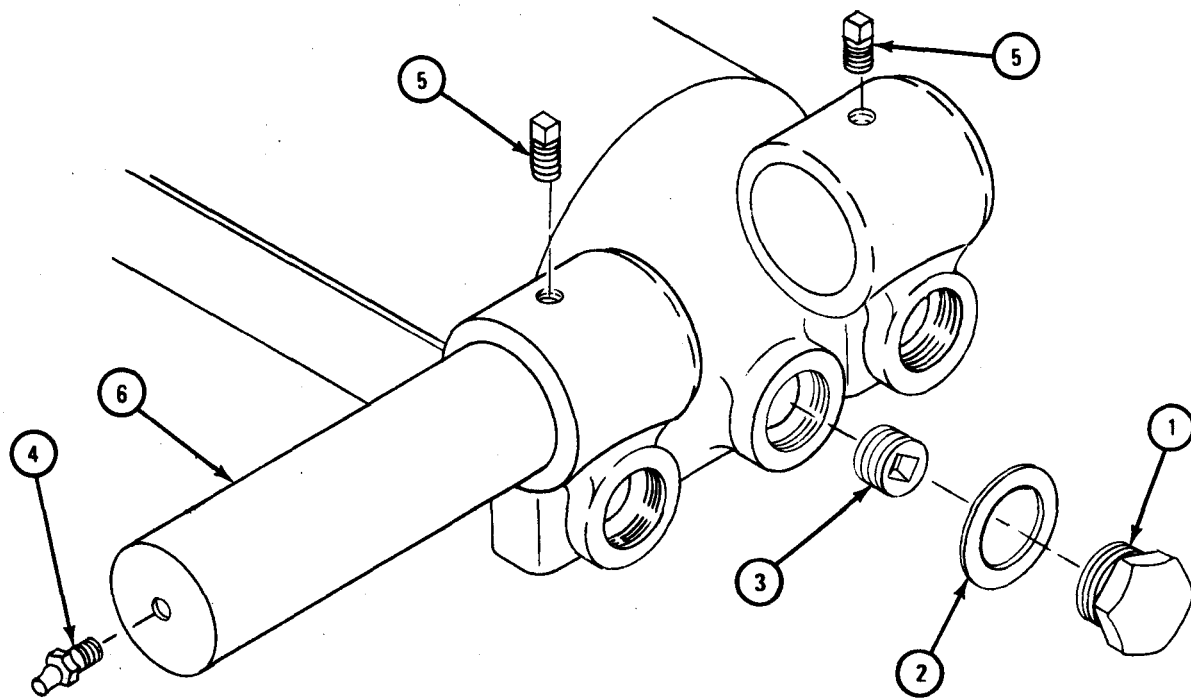

TA 084154

WARNING

Dry cleaning solvent is flammable. Do not use near an open flame. Keep a fire extinguisher nearby when solvent is used. Use only in well-ventilated places. Failure to do this may result in injury to personnel, and damage to equipment.

d. Cleaning. Clean all parts in solvent. Make sure grease and oil passages are open.

e. Inspection.

FRAME 1

1. Check that tube assembly (1) is not cracked and does not have broken welds. Check that inner bore of tube assembly is not scratched or scored, and has no badly worn surfaces.
2. Check that oil passages in tube assembly (1) are not clogged or burred. Check that screw threads are not burred, stripped or crossed.
3. Check that cylinder head (2) and gland (3) are not cracked or broken, and that bores are not burred.
4. Check that piston (4) and three piston rings (5) are not nicked, scratched or cracked, and that they do not have worn surfaces.
5. Check that piston rod (6) is not bent, nicked or scratched, and that it does not have burred, stripped or crossed threads.
6. Check that pin (7) is not chipped or scored, and that it has no flat spots.

END OF TASK

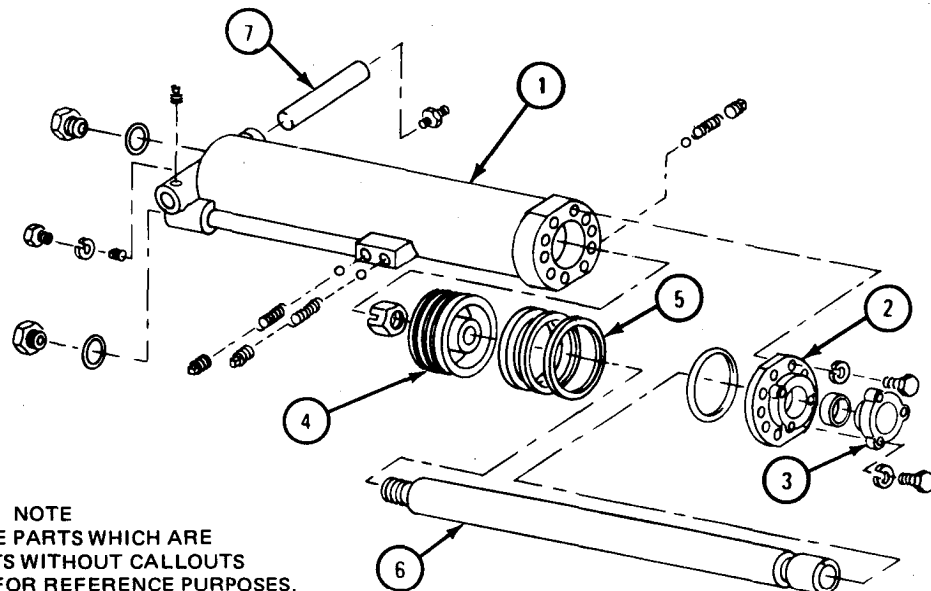

NOTE
CHECK ONLY THOSE PARTS WHICH ARE
CALLED OUT. PARTS WITHOUT CALLOUTS
ARE SHOWN ONLY FOR REFERENCE PURPOSES.

TA 084155

f. Repair.

(1) Using thread file, fix any damaged threads.

(2) Get new parts for any other damaged parts.

g. Assembly.

FRAME 1

1. Using brass hammer, drive pin (1) into bore in tube assembly (2) until pin is centered.
 2. Put in two setscrews (3).
 3. Put in lubrication fitting (4).
 4. Put in fluid flow plug resistor (5).
 5. Put in plug (6) and ring spacer (7).
- GO TO FRAME 2

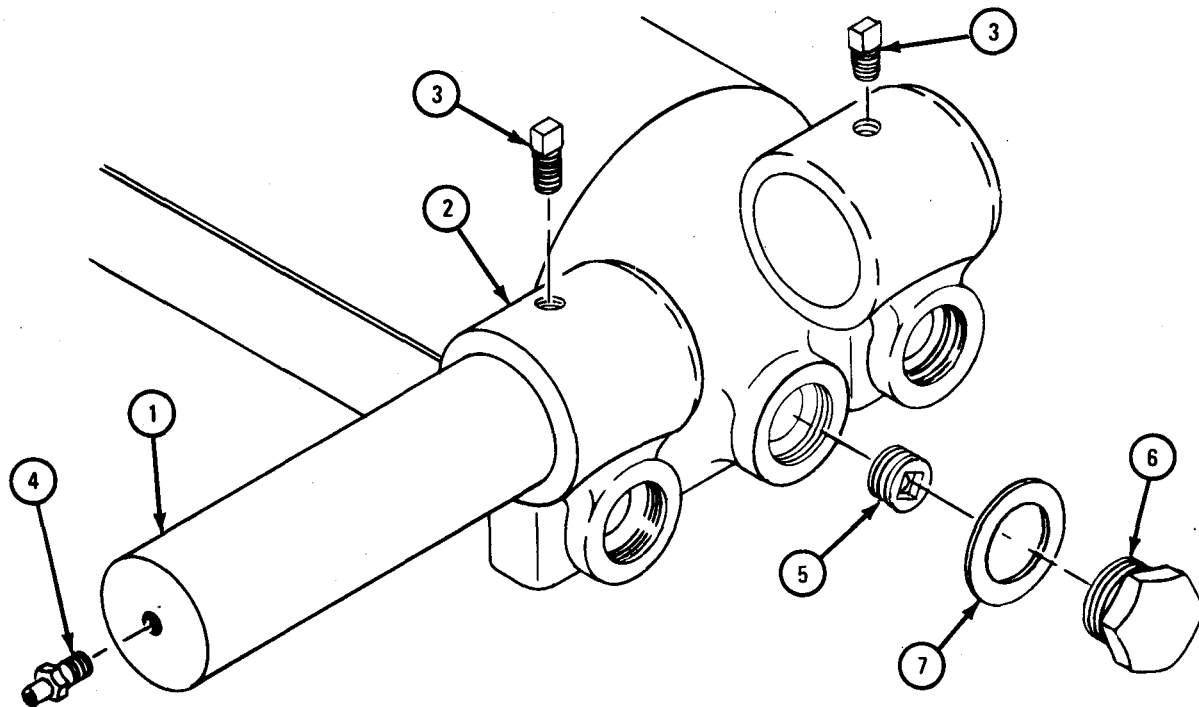

TA 084156

FRAME 2

1. Put three check balls (1) with three springs (2) in bores in tube assembly (3).
2. Put in three plugs (4).

GO TO FRAME 3

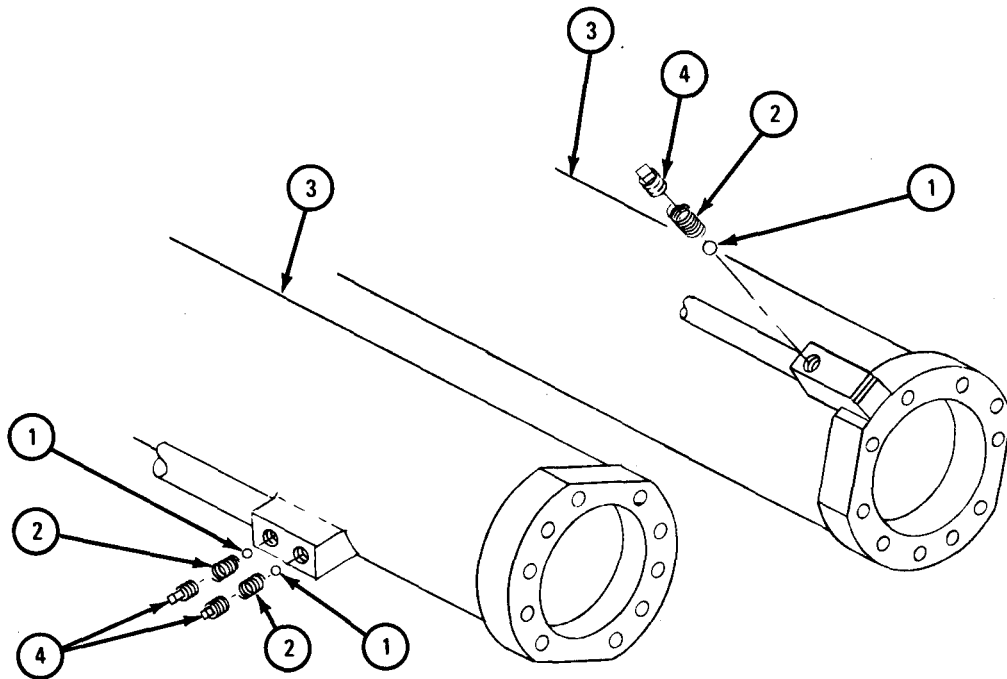

TA 084157

FRAME 3

1. Put three piston rings (1) in grooves in piston (2). Turn rings so that ring gaps are not aligned.
 2. Put grooved end of piston rod (3) in vise with soft jaw caps.
 3. Put piston (2) on piston rod (3).
 4. Put on nut (4).
 5. Put in cotter pin (5).
 6. Clamp piston ring compressor over piston rings (1).
 7. Take piston rod (3) out of vise.
- GO TO FRAME 4

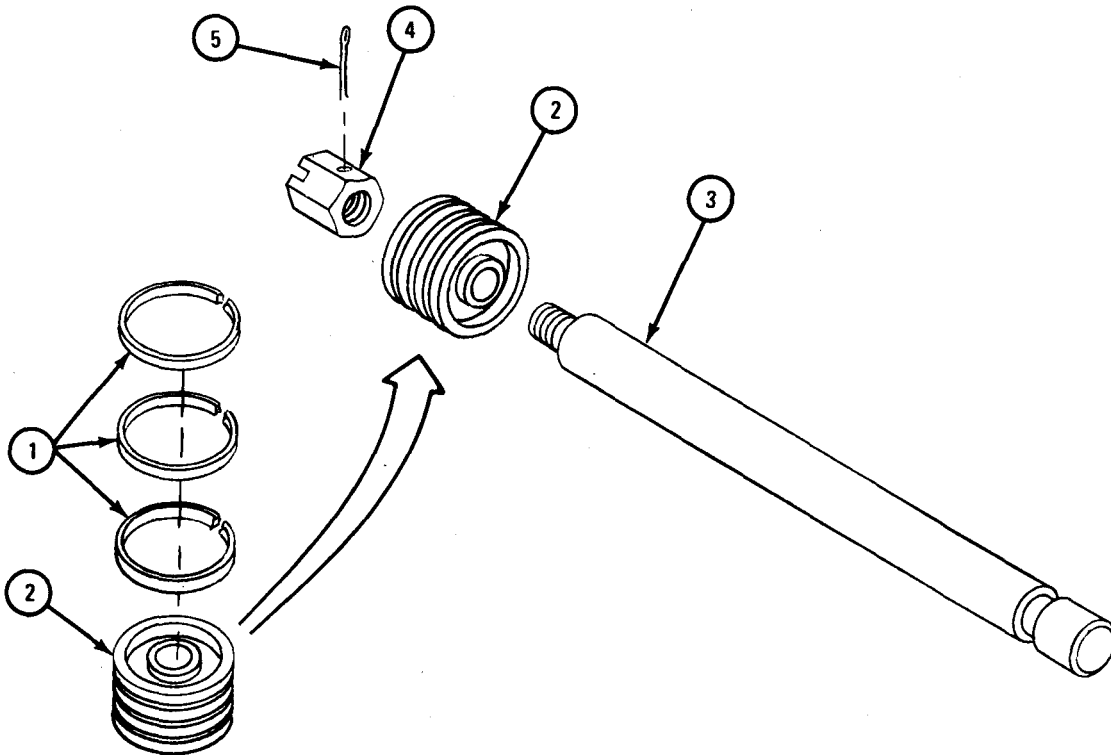

TA 084158

FRAME 4

1. Put a coat of oil in bore of cylinder assembly (1).
2. Carefully clamp closed end of cylinder assembly (1) in vise with soft jaw caps.
3. Carefully push piston rod assembly (2) into bore of cylinder assembly (1).
4. Take off ring compressor.
5. Put preformed packing (3) in place on cylinder head (4).
6. Slide cylinder head (4) with preformed packing (3) into place on piston rod assembly (2) and against cylinder assembly (1). Line up screw holes.
7. Put in 10 screws (5) with washers (6).
8. Tighten screws (5) to 35 pound-feet in tightening order shown.

GO TO FRAME 5

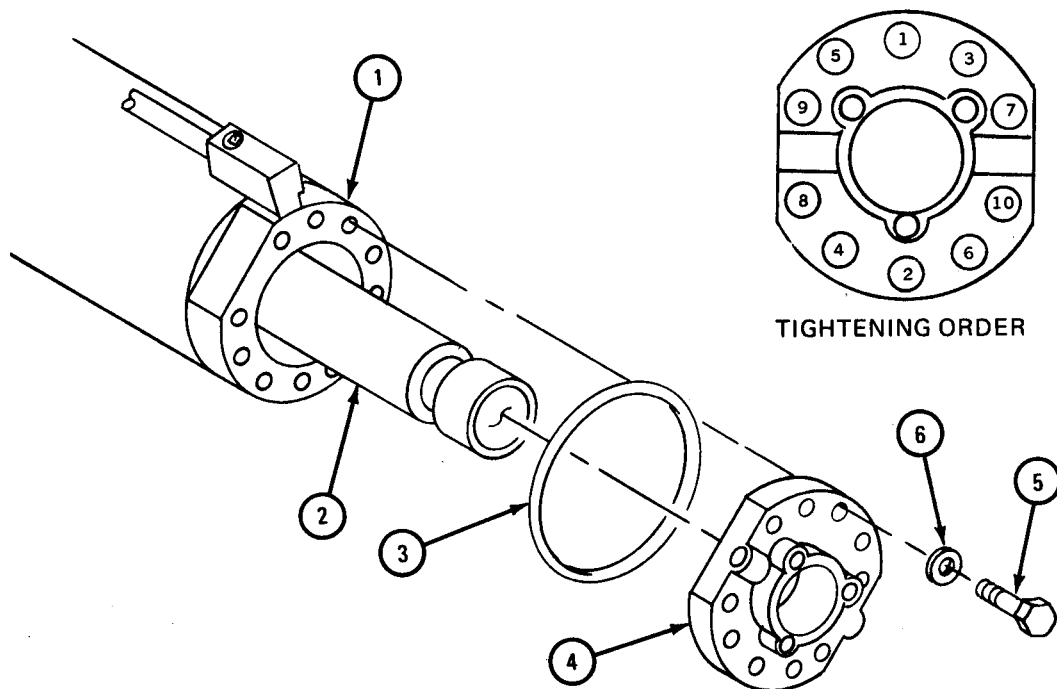

TA 084159

FRAME 5

1. Slide packing (1) and retainer (2) down piston rod (3) and into place in cylinder head (4).
2. Put in three bolts (5) and washers (6).
3. Tighten bolts (5) to 35 pound-feet.

END OF TASK

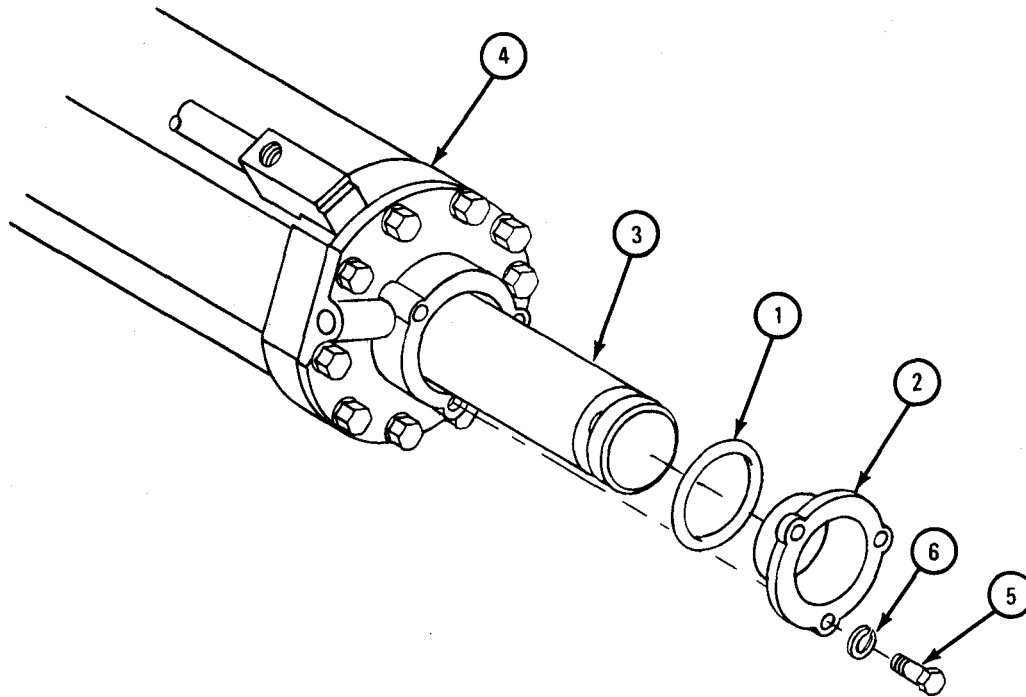

TA 084160

h. Replacement.

FRAME 1

CAUTION

Bypass tubes on outside of hoist cylinder assembly (1) are easily damaged. Be careful when replacing hoist cylinder assembly.

- | | | |
|------------------|----|---|
| Soldiers A and B | 1. | Lift hoist cylinder assembly (1) into place on truck. Seat pin of hoist cylinder assembly in two bearing seats (2). |
| Soldier A | 2. | Place wood block under end of cylinder assembly (1). |
| Soldier B | 3. | Put two bearing caps (3) in place. |
| | 4. | Put in four screws and lockwashers (4). |
| Soldiers A and B | 5. | Slide piston rod (5) into bore in crosshead (6). Line up groove in piston rod with slots in crosshead. |
| Soldier A | 6. | Hold hoist cylinder assembly (1) in place. |
| Soldier B | 7. | Put upper retainer (7) in slot in crosshead (6) and hold lower retainer (8) in place in slot in crosshead. |
| | 8. | Put in two screws and lockwashers (9). |

GO TO FRAME 2

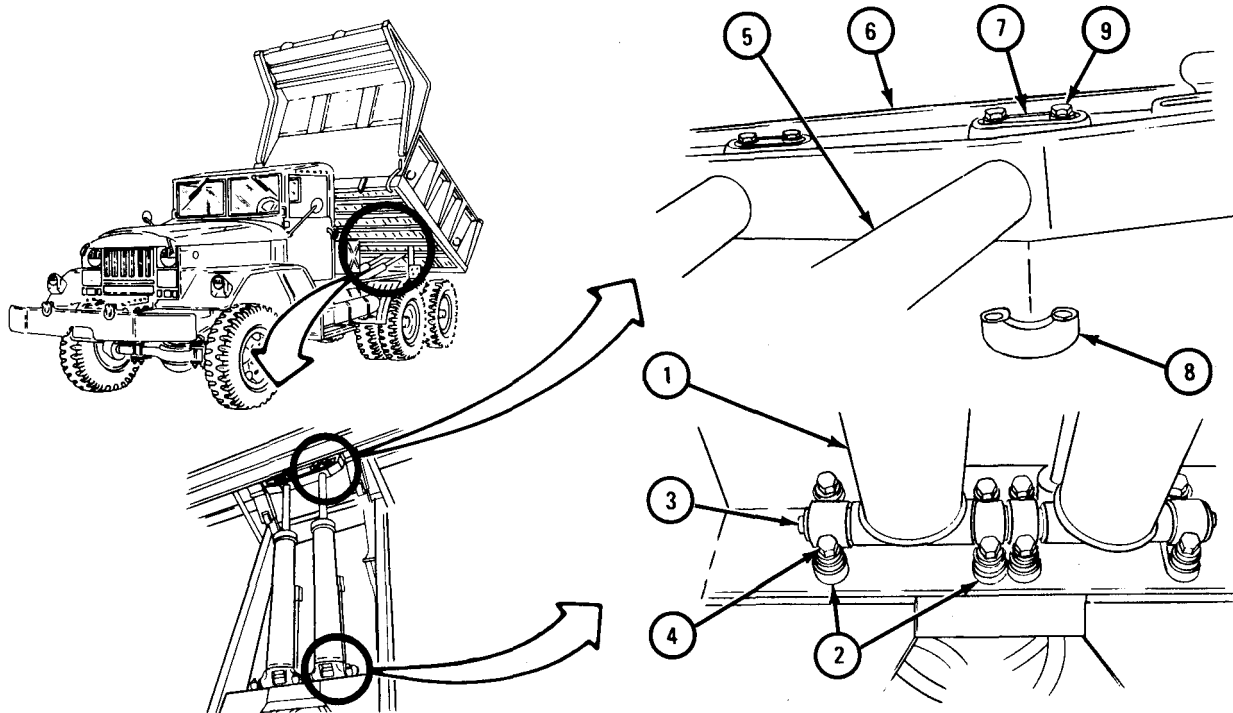

TA 084161

FRAME 2

1. Put two hoses (1 and 2) in place on hoisting cylinder (3) as tagged.
2. Put in two adapters (4) and spacers (5). Take off tags.

NOTE

Follow-on Maintenance Action Required:

1. Unlock safety braces. Refer to TM 9-2320-209-20.
2. Lower dump body and stop engine. Refer to TM 9-2320-209-10.
3. Fill hydraulic reservoir. Refer to LO 9-2320-209-12/1.
4. Check hoist assembly for proper operation. Refer to TM 9-2320-209-10.

END OF TASK

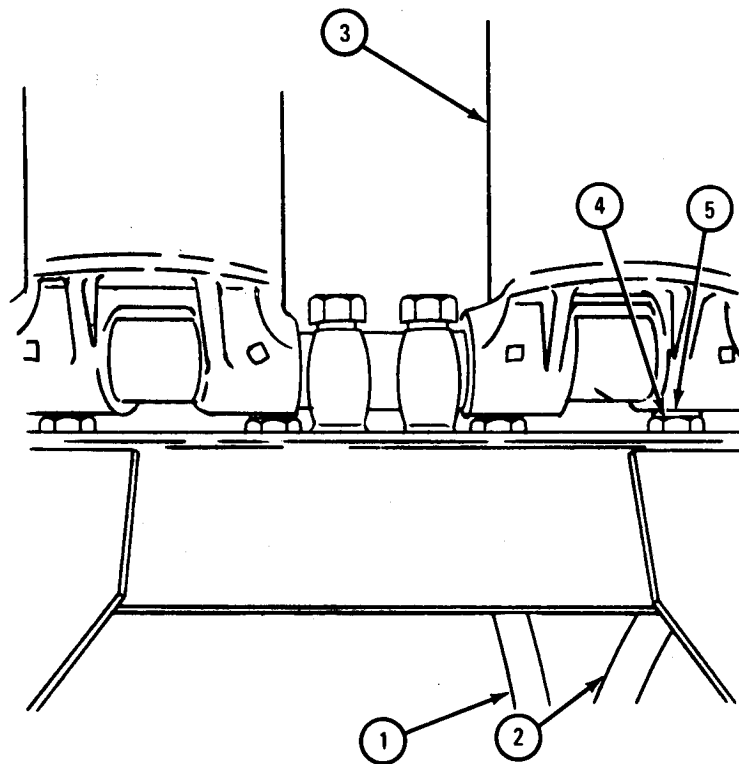

TA 084162

18-9. HYDRAULIC HOIST PUMP ASSEMBLY REMOVAL, REPAIR, AND REPLACEMENT (TRUCK M342A2).

TOOLS: No special tools required

SUPPLIES: None

PERSONNEL: Two

EQUIPMENT CONDITION: Truck parked, engine off, handbrake set.

a. Preliminary Procedures.

(1) Drain hydraulic reservoir. Refer to LO 9-2320-209-12/1.

(2) Take power takeoff-to-pump propeller shaft off hoist pump assembly. Refer to TM 9-2320-209-20.

b. Removal.

FRAME 1

- Soldier A 1. Put container under pump assembly (1) before taking it off.
 2. Working under truck, hold pump assembly (1).
 Soldier B 3. Working under truck, take out six screws (2) and lockwashers (3).
 Soldiers A and B 4. Take out pump assembly (1) and gasket (4). Throw away gasket.
 END OF TASK

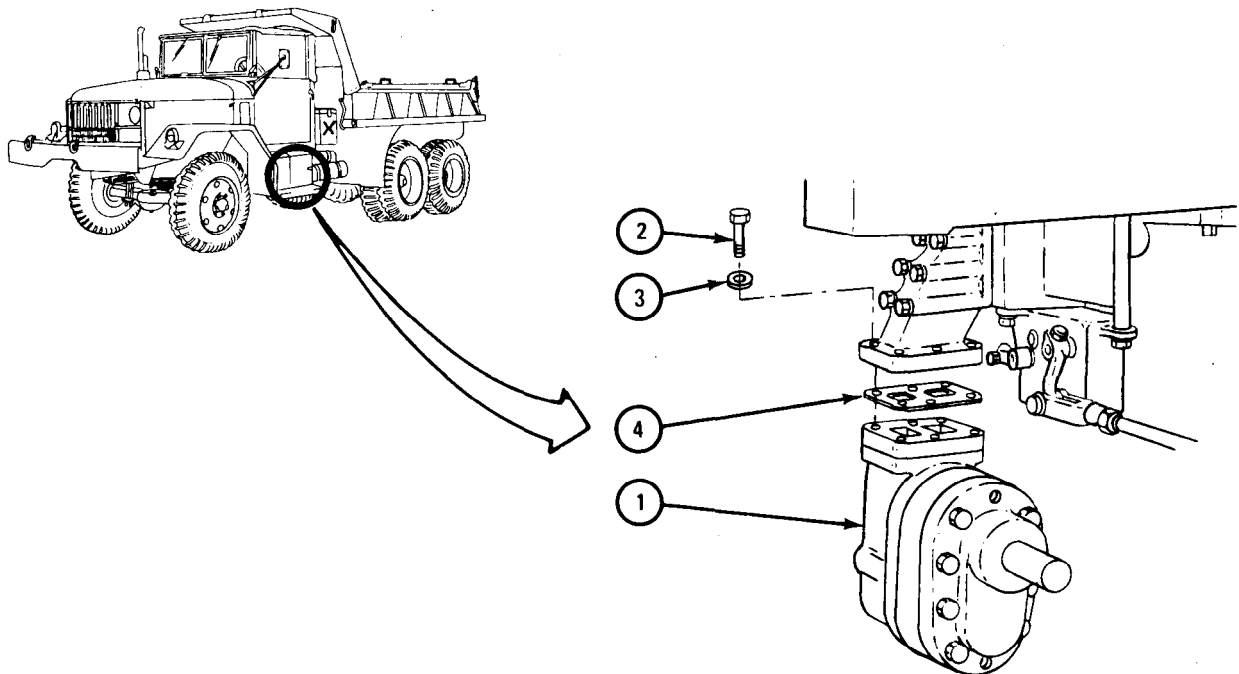

TA 084132

c. Disassembly.

FRAME 1

1. Clamp hoist pump assembly (1) in vise with soft jaw caps.
2. Take out key (2).
3. Take out eight screws (3) and lockwashers (4).
4. Take off front end cover (5).
5. Using puller, take off two bearings (6) and oil seal assembly (7). Refer to Part 1, para 10-8. Throw away oil seal.
6. Take hoist pump assembly (1) out of vise.

GO TO FRAME 2

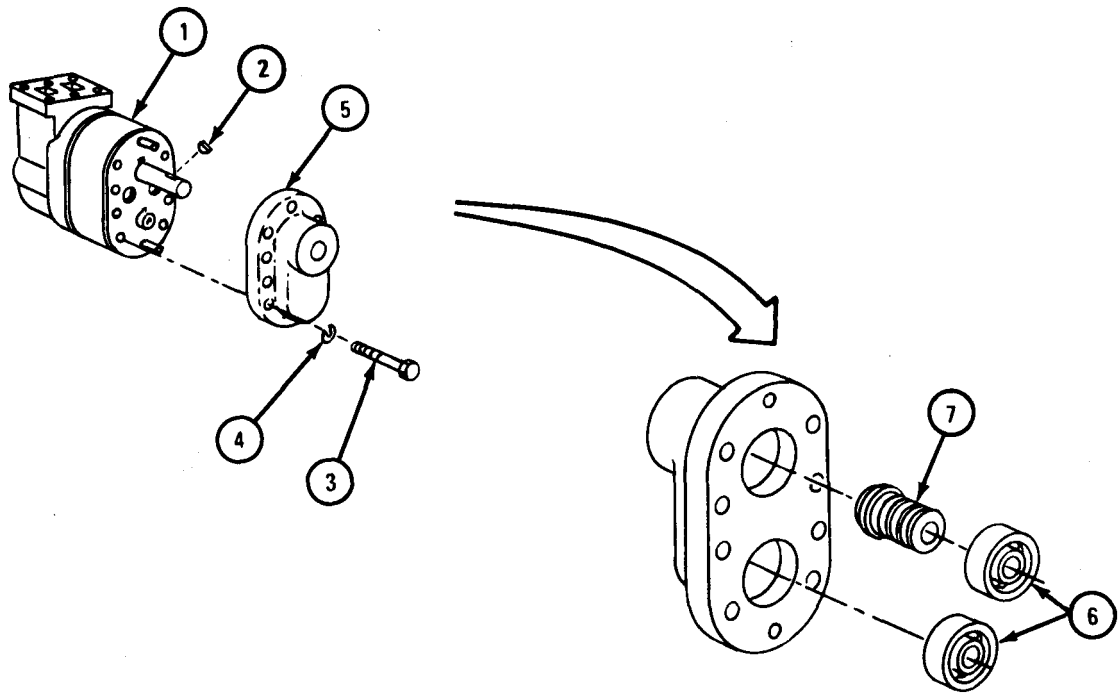

TA 084133

FRAME 2

NOTE

Note positions of wear plates (1 and 2) so that they are put back in the same place.

1. Pull off wear plate (1). Take care not to scratch or nick it.
2. Pull out drive shaft assembly (3) and driven shaft assembly (4). Take care not to scratch or nick them.
3. Pull off pump body (5).
4. Pull off wear plate (2). Take care not to scratch or nick it.
5. Using puller, take off two bearings (6). Refer to Part 1, para 10-8.
6. Take out four guide pins (7).

GO TO FRAME 3

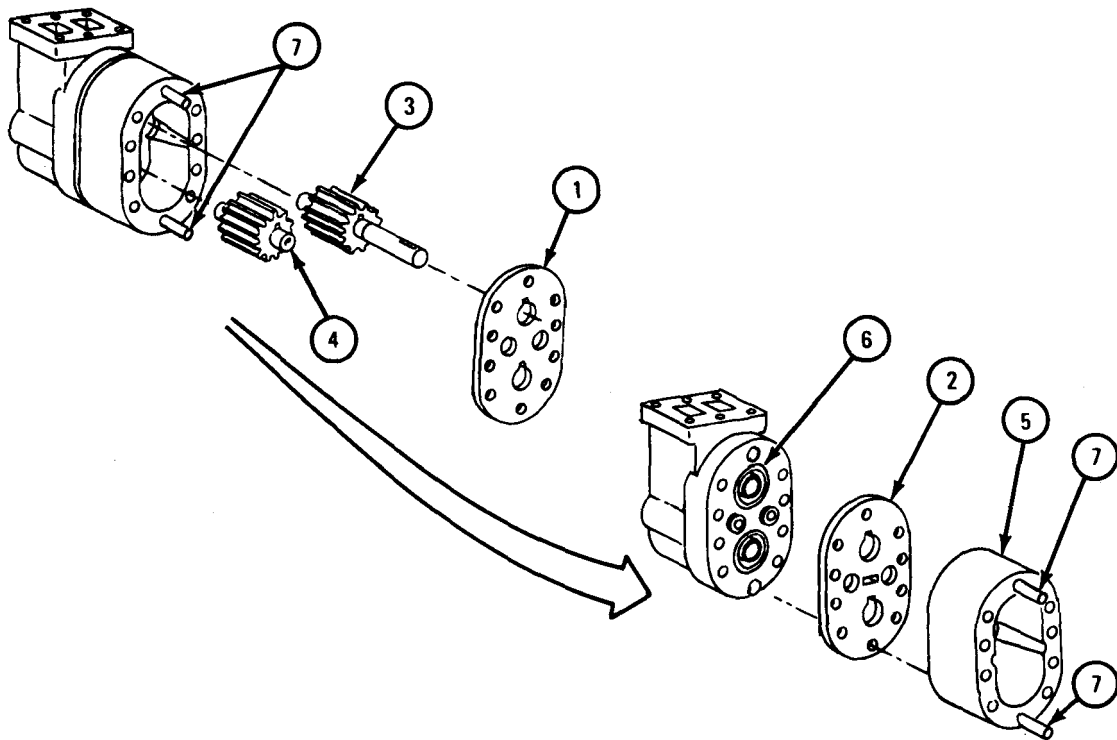

TA 084134

FRAME 3

1. Press gear (1) off drive shaft (2).
 2. Take key (3) out of drive shaft (2).
 3. Press gear (4) off driven shaft (5).
- END OF TASK

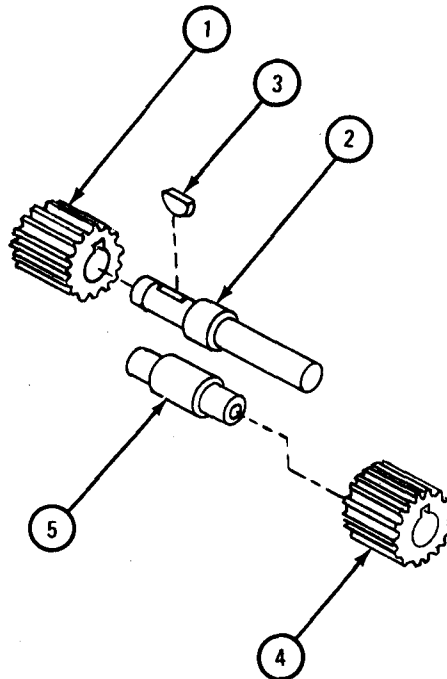

TA 084135

d. Cleaning.

- (1) Clean bearings. Refer to Part 1, para 10-8.

WARNING

Dry cleaning solvent is flammable. Do not use near an open flame. Keep a fire extinguisher nearby when solvent is used. Use only in well-ventilated places. Failure to do this may result in injury to personnel and damage to equipment.

- (2) Clean all other parts in solvent.

FRAME 1

1. Check that front end cover (1), pump body (2), and rear end cover (3) are not cracked or broken, and that bores are not scored or worn.
2. Check that two wear plates (4) have no nicks, burrs or deep scratches.
3. Check that two gears (5) have no nicks, burrs, deep scratches or broken teeth.
4. Check that drive gearshaft (6) and driven gearshaft (7) are not cracked or scored.
5. Check that four bearings (8) are not damaged. Refer to Part 1, para 10-8.
6. Check that four pins (9) have no nicks, burrs, or deep scratches.

END OF TASK

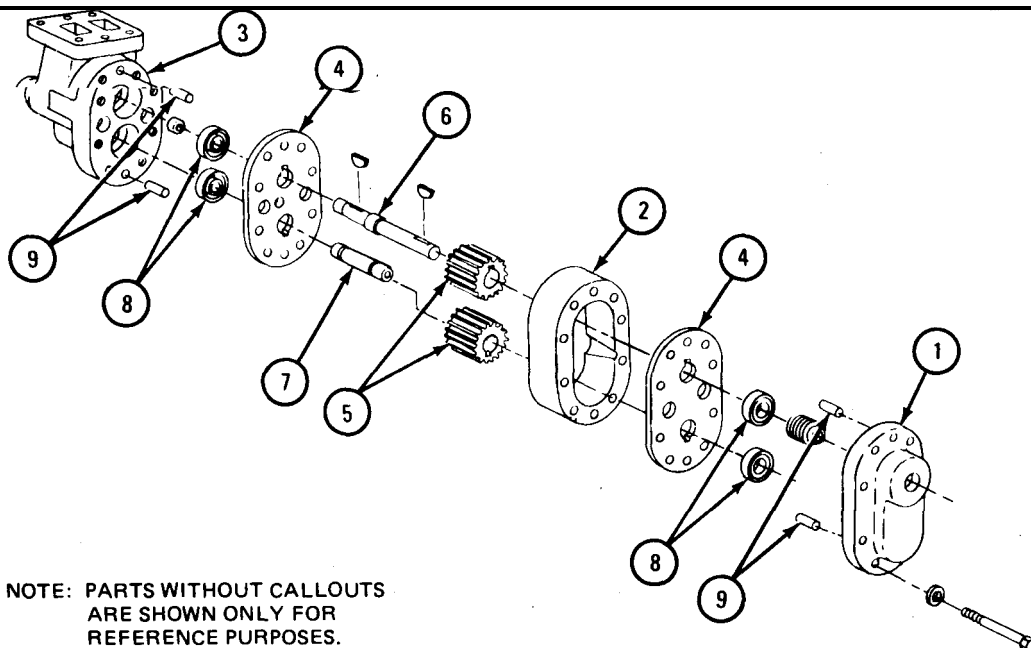

TA 084136

f. Repair.

(1) If front end cover, pump body or rear end cover is damaged, get a new hoist pump assembly.

(2) Use honing stone to smooth raised metal from gears. If gears cannot be repaired with honing stone, get new ones in their place.

(3) Get new parts for another damaged parts.

g. Assembly.

FRAME 1

1. Press gear (1) onto driven shaft (2). Center gear between marks (3).
2. Tap key (4) into slot on drive shaft (5).
3. Press gear (6) onto key (4) and drive shaft (5). Center gear between marks (7).

GO TO FRAME 2

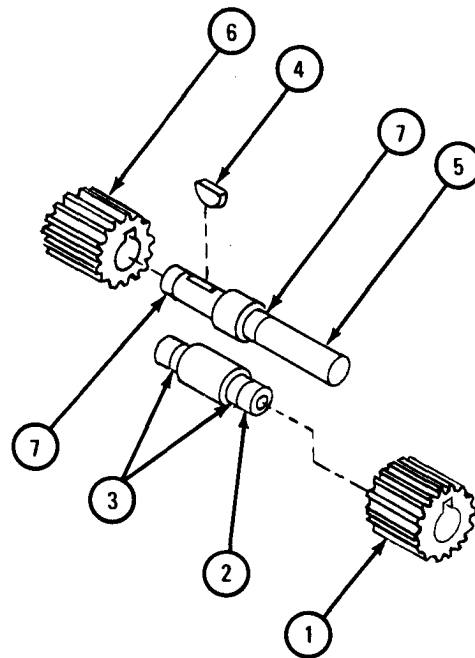

TA 084137

FRAME 2

NOTE

Put wear plates (1 and 2) back in same positions noted.

1. Press two bearings (3) into bores in rear end cover (4). Refer to Part 1, para 10-8.
2. Put wear plate (1) in place against rear end cover (4). Take care not to scratch or nick wear plate.
3. Put in two guide pins (5).
4. Put pump body (6) on guide pins (5) and push it in place against wear plate (1). Notch on pump body must be on same side as notch on rear end cover (4).
5. Put drive shaft assembly (7) and driven shaft assembly (8) into bores of bearings (3). Take care not to scratch or nick bearings or shafts.
6. Put in two guide pins (9).
7. Put wear plate (2) on drive shaft assembly (7) and driven shaft assembly (8) and push it onto guide pins (9) in pump body (6). Take care not to scratch or nick wear plate.

GO TO FRAME 3

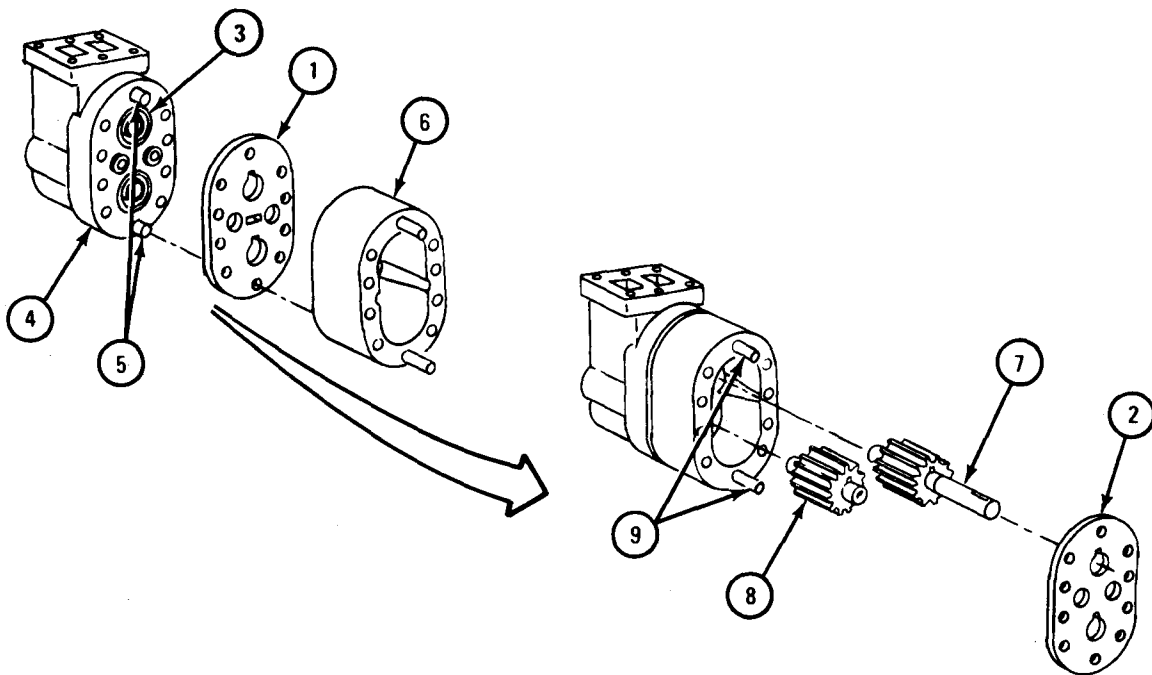

TA 084138

FRAME 3

1. Press oil seal assembly (1) and two bearings (2) into front end cover (3). Refer to Part 1, para 10-8.
2. Line up front end cover (3) with drive shaft assembly (4), driven shaft assembly (5), and guide pins (6).
3. Push front end cover (3) onto guide pins (6) and against hoist pump assembly (7).
4. Carefully clamp hoist pump assembly (7) in vise with soft caps,
5. Put in eight screws (8) with lockwashers (9).
6. Tighten screws (8) to 30 to 40 pound-feet.
7. Tap key (10) in slot in drive shaft assembly (4).
8. Take hoist pump assembly (7) out of vise.

END OF TASK

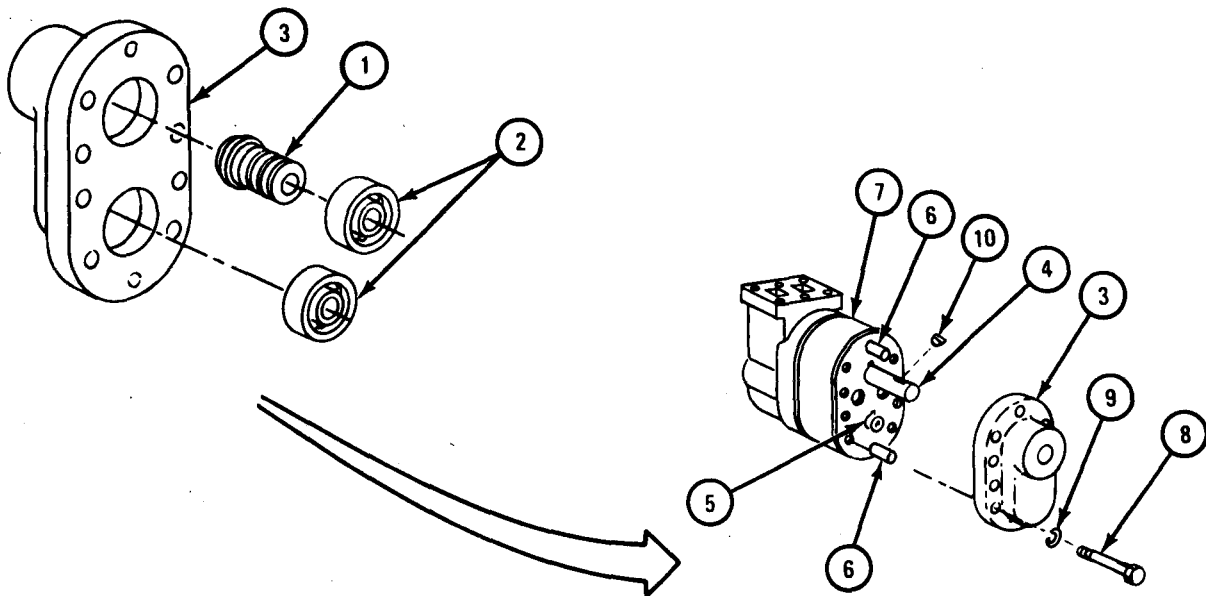

TA 084139

h. Replacement.

FRAME 1

- Soldier A 1. Working under truck, hold hoist pump assembly (1) and gasket (2) in place on valve adapter (3).
- Soldier B 2. Put in six screws (4) and washers (5).

NOTE

Follow-on Maintenance Action Required:

1. Put back power takeoff-to-pump propeller shaft. Refer to TM 9-2320-209-20.
2. Fill hydraulic reservoir. Refer to LO 9-2320-209-12/1.

END OF TASK

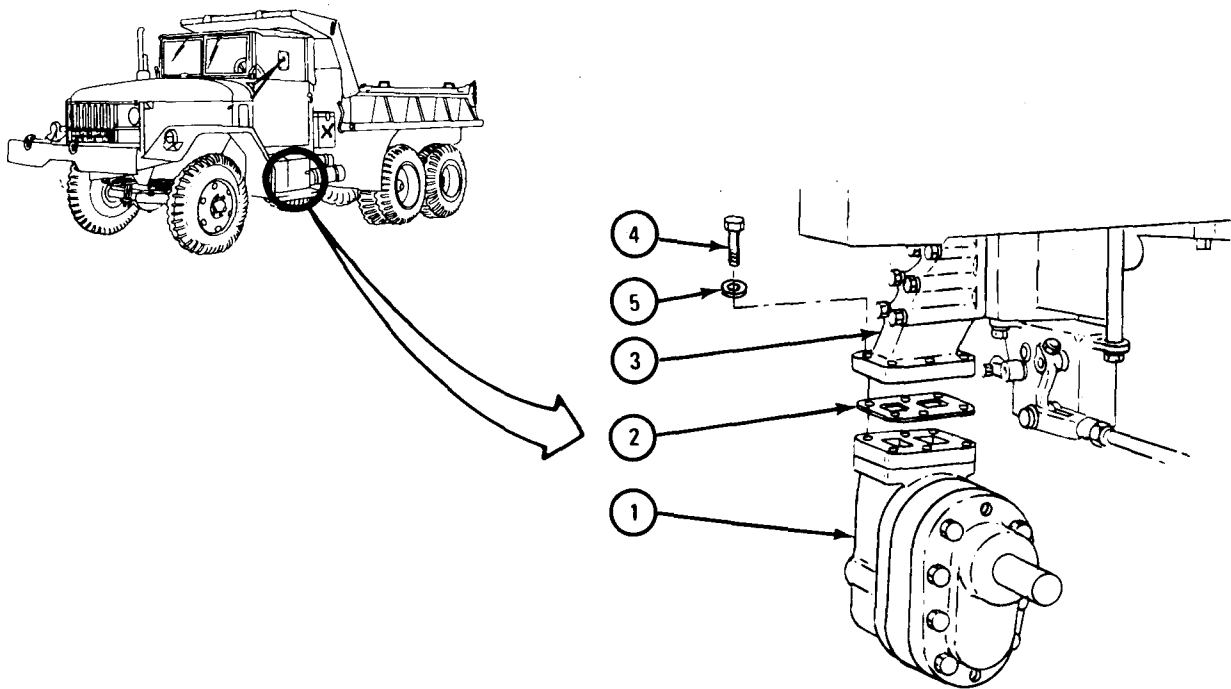

TA 084140

18-10. CONTROL VALVE REMOVAL AND REPLACEMENT (TRUCK M342A2).

TOOLS: No special tools required

SUPPLIES: Control valve gasket

PERSONNEL: One

EQUIPMENT CONDITION: Truck parked, engine off, handbrake set.

a. Preliminary Procedures.

(1) Raise and brace dump body. Refer to TM 9-2320-209-10.

(2) Drain hydraulic reservoir. Refer to LO 9-2320-209-20-12/1.

(3) Remove power takeoff propeller shaft. Refer to Propeller Shaft and Universal Joint Removal and Replacement, TM 9-2320-209-20.

(4) Remove hydraulic pump adapter and spacer. Refer to para 18-9.

b. Removal.

FRAME 1

1. Unscrew and takeoff locknut (1) and takeout screw (2).

2. Take hoist control valve lever (3) off control box (4) and trunnion (5).

GO TO FRAME 2

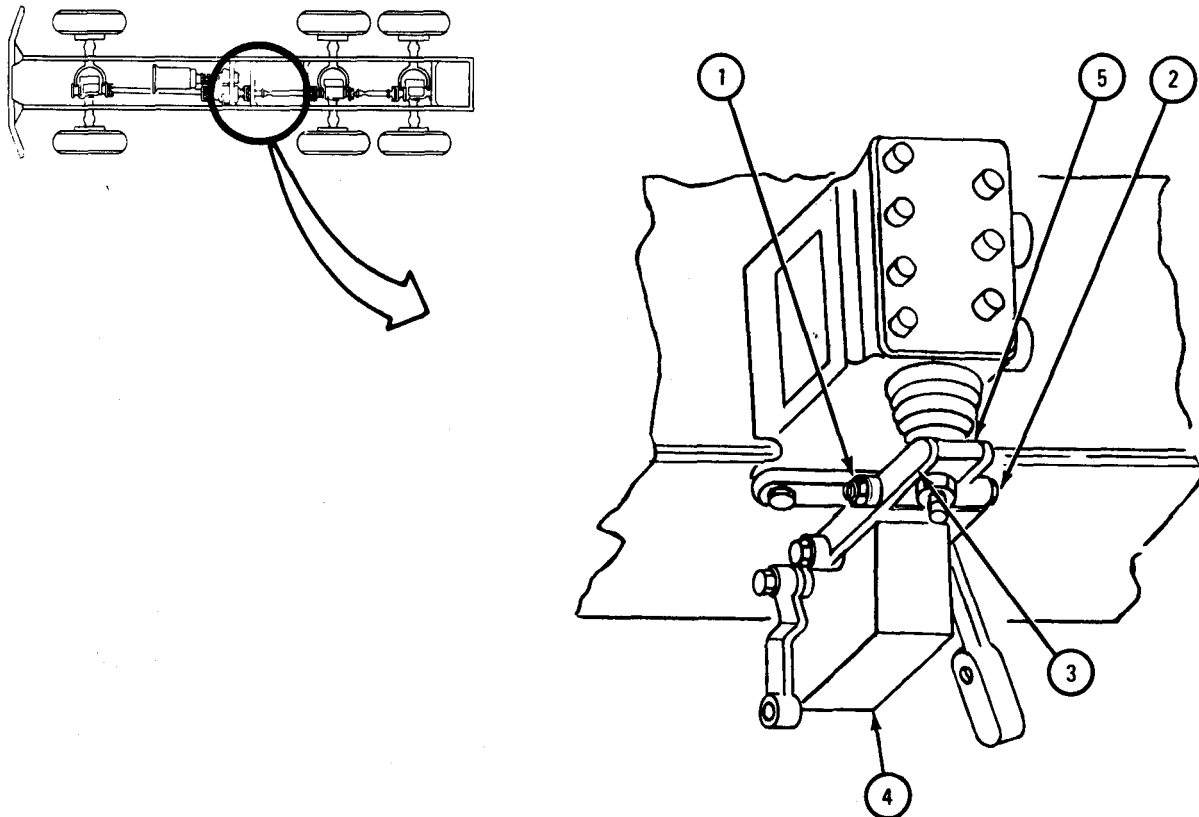

TA 105680

FRAME 2

NOTE

Tag four hydraulic lines (2) so they can be put back in the same place.

1. Unscrew four coupling nuts (1) and take off four hydraulic lines (2) and move them out of the way.
2. Unscrew and take out seven screws (3), lockwashers (4), and take off control valve cover (5), two gaskets (6), and control valve body (7).

END OF TASK

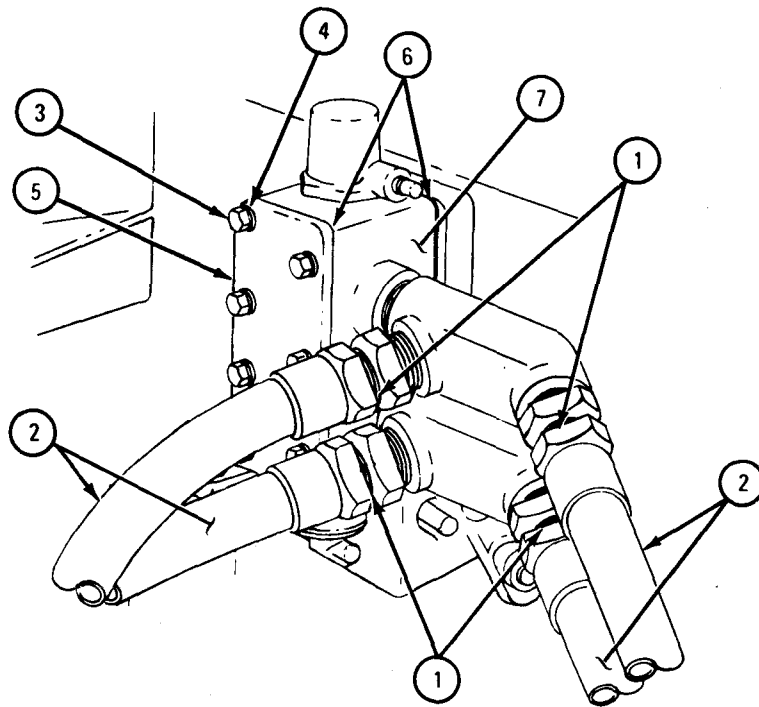

TA 101874

c. Replacement.

FRAME 1

1. Put control valve cover (1), gasket (2), control valve body (3), and gasket (4) in place on subframe (5), aligning holes.
2. Screw in and tighten seven screws (6) and lockwashers (7).
3. Put four hydraulic lines (8) in place and screw on and tighten four coupling nuts (9).

GO TO FRAME 2

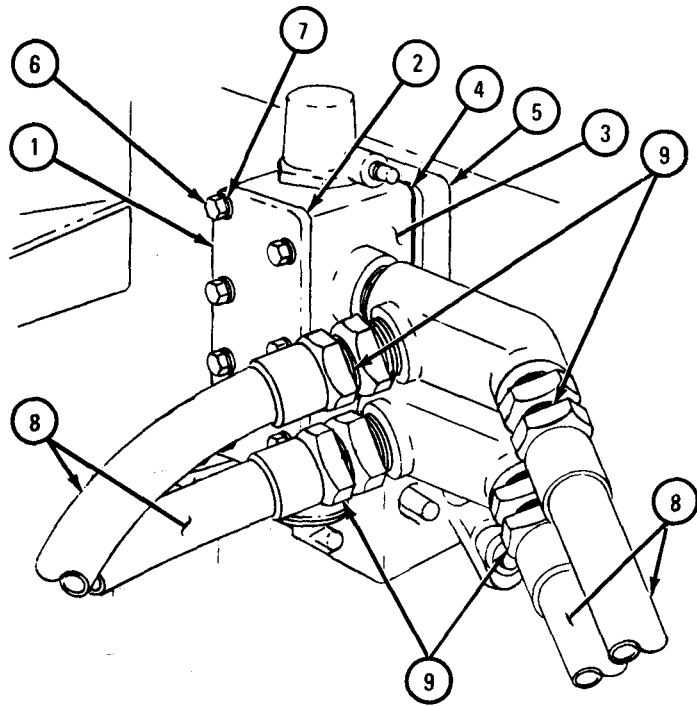

TA 101875

FRAME 2

1. Put hoist control valve lever (1) on control box (2) and trunnion (3).
2. Put in screw (4) and screw on and tighten locknut (5).

NOTE

Follow-on Maintenance Action Required:

1. Replace hydraulic pump adapter and spacer. Refer to para 18-9.
2. Replace power takeoff propeller shaft. Refer to Propeller Shaft and Universal Joint Removal and Replacement, TM 9-2320-209-20.
3. Fill hydraulic system. Refer to LO 9-2320-209-12/1.
4. Raise dump body and drop braces. Lower dump body . Refer to TM 9-2320-209-10.

END OF TASK

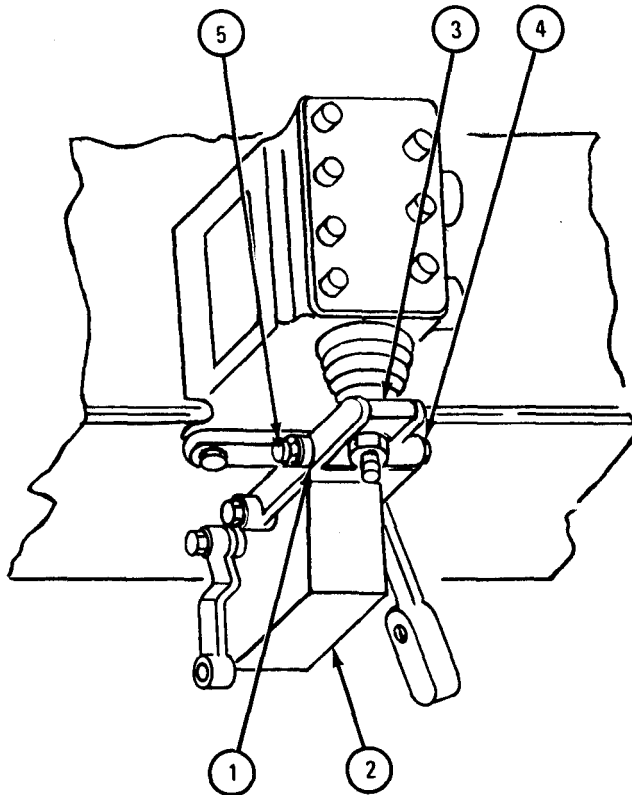

TA 105681

18-11. POWER DIVIDER INPUT AND REAR OUTPUT SHAFT OIL SEALS REMOVAL
AND REPLACEMENT (TRUCK M764).

NOTE

This task is the same for the input shaft and rear output shaft oil seals. This task is shown for the input shaft oil seal.

TOOLS: No special tools required

SUPPLIES: Cotter pin
Clean rags
Solvent, dry cleaning, type II (SD-2), Fed. Spec P-D-680
Gear lubricating oil, GO 80/90, MIL-L-2105
Input shaft oil seal
Rear output shaft oil seal

PERSONNEL: One

EQUIPMENT CONDITION: Truck parked, engine off, handbrake set.

a. Removal.

FRAME 1

NOTE

Input shaft and rear output shaft oil seals can be worked on with power divider in truck.

1. Take out four bolts (1), washers (2), and nuts (3).
2. Take off propeller shaft (4) from companion flange (5).
3. Take out drain plug (6) and drain enough oil to half fill a one-gallon container. Put oil in an approved disposal area.
4. Put in drain plug (6).

GO TO FRAME 2

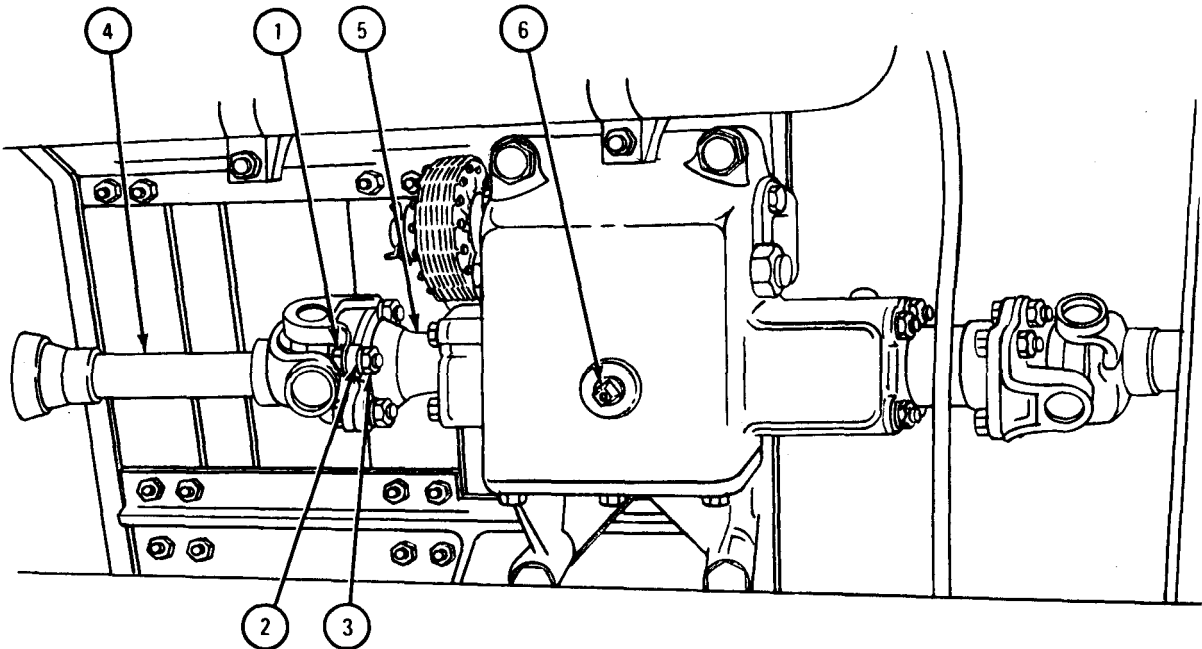

TA 088942

FRAME 2

1. Take out cotter pin (1).
2. Takeout nut (2) and washer (3). Takeoff companion flange (4).
3. Pull out sleeve bearing (5).

CAUTION

Be careful not to damage seat for oil seal (6) when taking out oil seal. Damaged seat can cause oil leakage and damage to equipment.

4. Drive pointed punch into metal case of oil seal (6). Take out oil seal from bearing cap (7) and throw it away.

END OF TASK

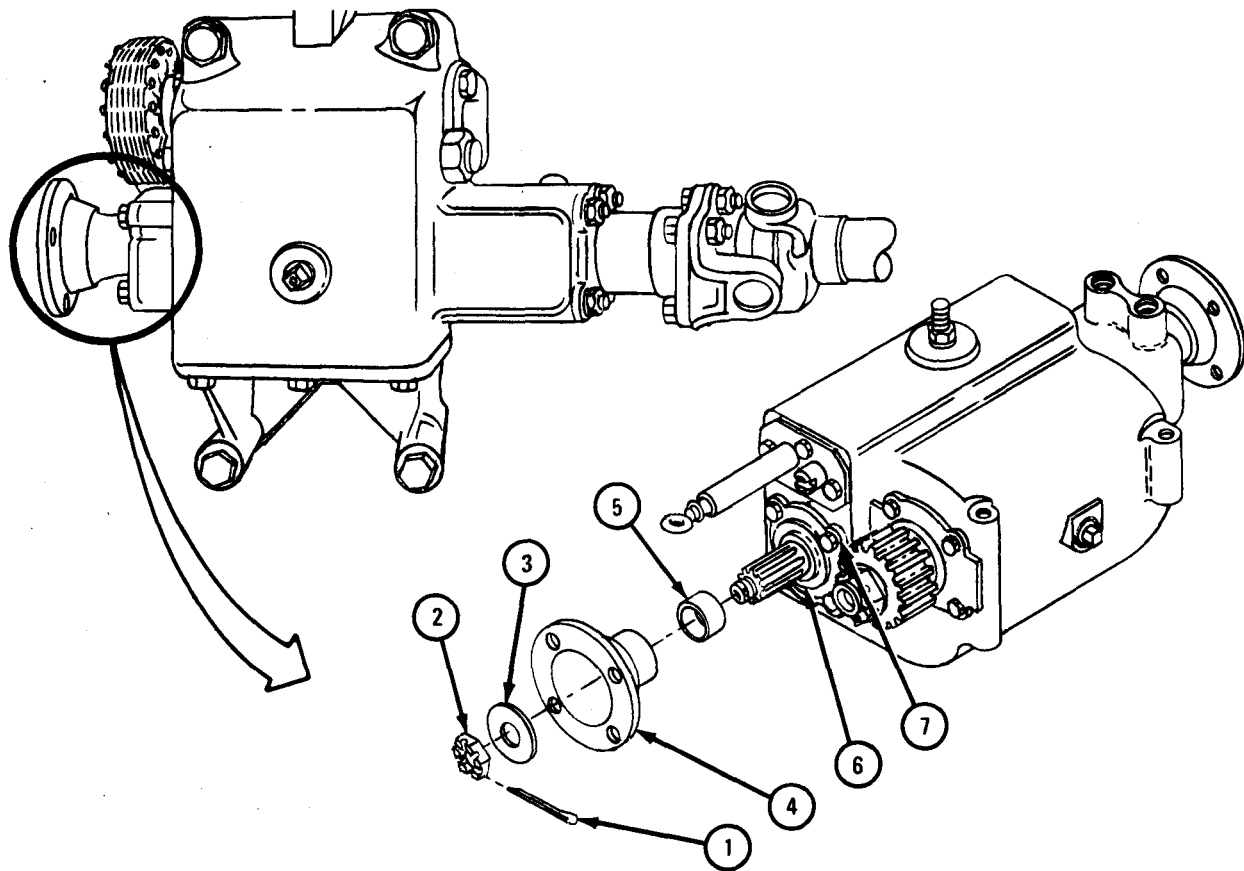

TA 088943

b. Cleaning.

WARNING

Dry cleaning solvent is flammable. Do not use near an open flame. Keep a fire extinguisher nearby when solvent is used. Use only in well-ventilated places. Failure to do this may result in injury to personnel and damage to equipment.

CAUTION

Do not let solvent get inside power divider housing. Solvent will break down gear lubricating oil and cause damage to operation of power divider.

- (1) Carefully clean oil seal seat with solvent.
- (2) Dry part with clean rags.

Replacement.

FRAME 1

1. Carefully tap oil (1) into bearing cap (2). Be sure that seal lip is facing power divider (3) and that seat case is flush with bearing cap.
2. Put sleeve bearing (4) on shaft (5). Slide sleeve bearing into oil seal (1). Be sure that seal lip is seated around sleeve bearing.
3. Put companion flange (6) on shaft (5). Put on nut (7) and washer (8).
4. Put on cotter pin (9).

GO TO FRAME 2

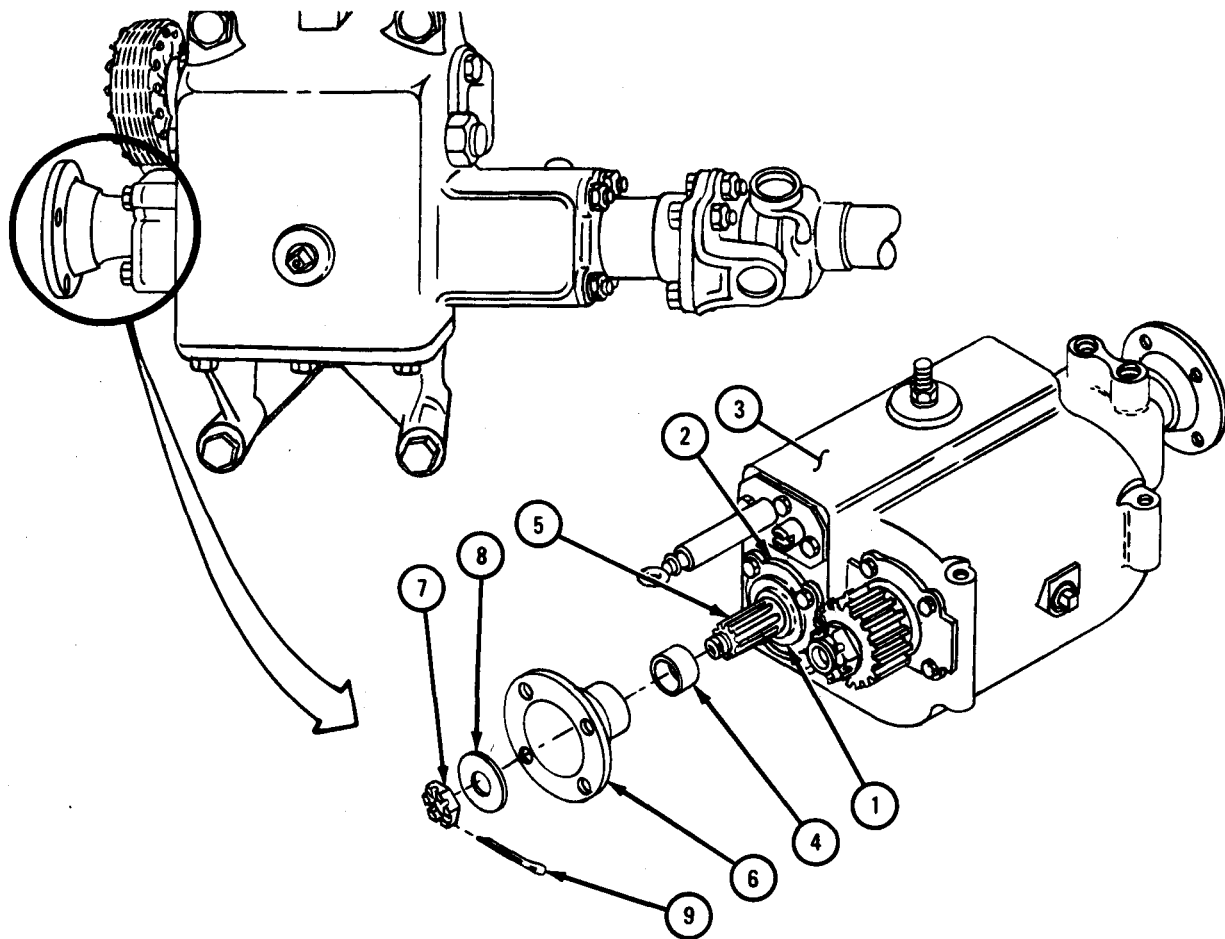

TA 088944

FRAME 2

1. Put propeller shaft (1) on companion flange (2).
2. Put in four bolts (3), washers (4), and nuts (5).
3. Fill power divider. Refer to LO 9-2320-209-12/1.
4. Check that there are no oil leaks. If oil is leaking, take off propeller shaft and companion flange and seat sleeve bearing properly in oil seal. Refer to para 18-11a.

END OF TASK

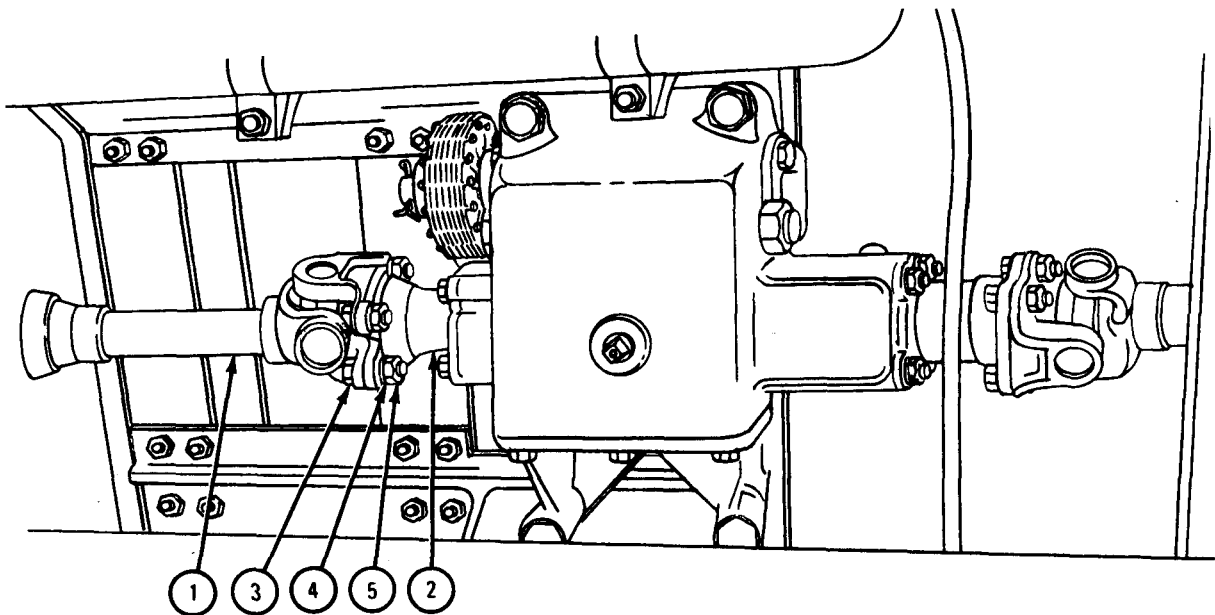

TA 088945

18-12. POWER DIVIDER REMOVAL, REPAIR, AND REPLACEMENT (TRUCK M764).

TOOLS: No special tools required

SUPPLIES: Housing gasket
Lubricating oil, ICE, OE/HDO-10, MIL-L-2104
Crocus cloth, type J
Cotter pins
Solvent, dry cleaning, type II (SD-2), Fed. Spec P-D-680
Gear lubricating oil, GO 80/90, MIL-L-2105

PERSONNEL: Two

EQUIPMENT CONDITION: Truck parked, engine off, handbrake set.

a. Preliminary Procedures.

- (1) Remove power divider propeller shaft. Refer to TM 9-2320-209-20.
- (2) Remove earth boring machine propeller shaft. Refer to TM 9-2320-209-20.
- (3) Remove transfer-to-forward-rear axle propeller shaft. Refer to Propeller Shaft and Universal Joint Removal and Replacement, TM 9-2320-209-20.
- (4) Vent air system pressure. Refer to TM 9-2320-209-20.

b. Removal.

FRAME 1

1. Working at front of right air reservoir (1), unscrew coupling nut (2).
2. Unscrew and take off two capscrews (3) and locknuts (4). Take off retaining straps (5).

GO TO FRAME 2

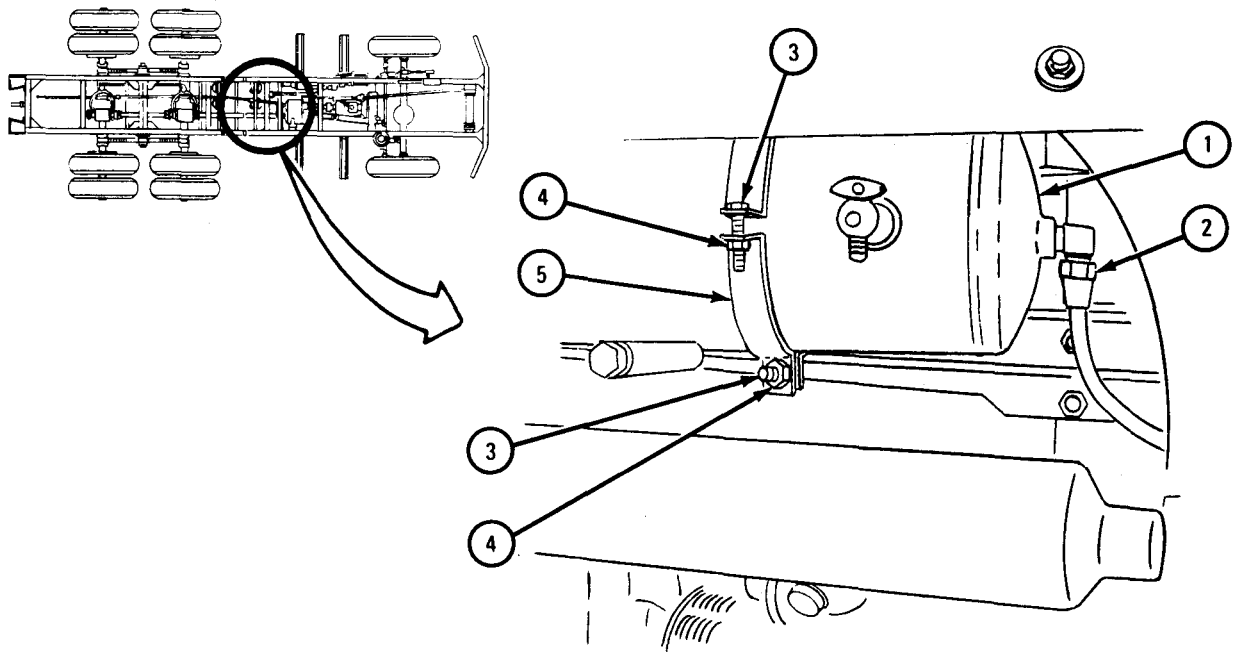

TA 088493

FRAME 2

Soldier A 1. Working at rear of air reservoir (1), unscrew and take off coupling nuts (2) from end of air line (3).

Soldier B 2. Hold air reservoir (1) in place to keep it from falling.

Soldier A 3. Unscrew and take off two capscrews (4) and locknuts (5). Take off retaining strap (6).

Soldiers 4. Take off right air reservoir (1).
A and B

GO TO FRAME 3

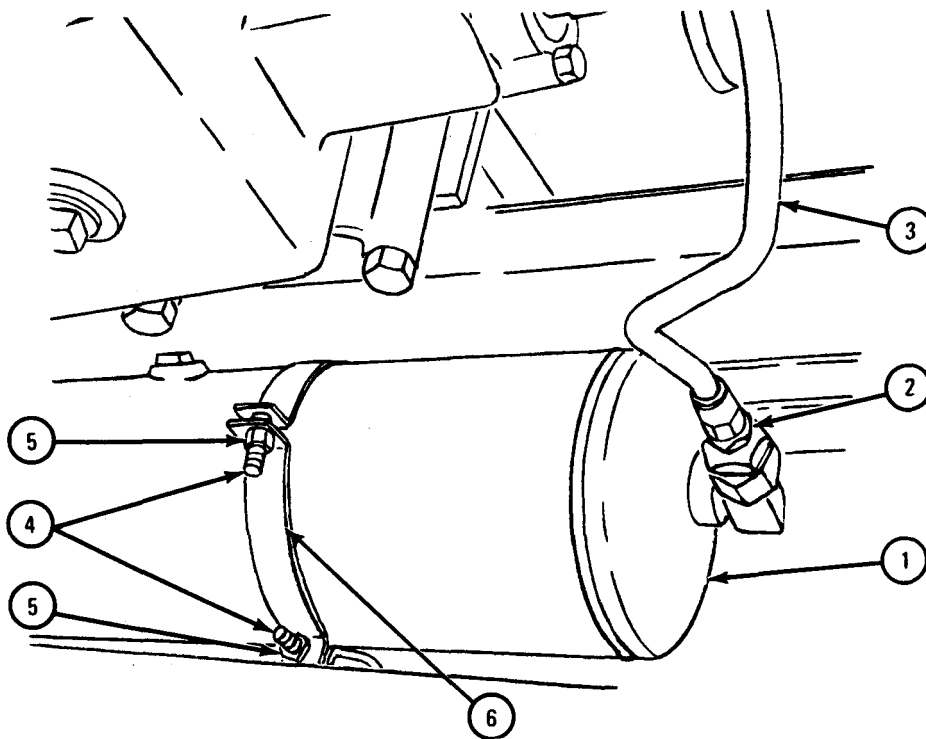

TA 088494

FRAME 3

1. Loosen locknut (1).
2. Loosen adjusting bolt (2).
3. Take out four screws and washers (3).
4. Take out idler pulley and bracket assembly (4).

GO TO FRAME 4

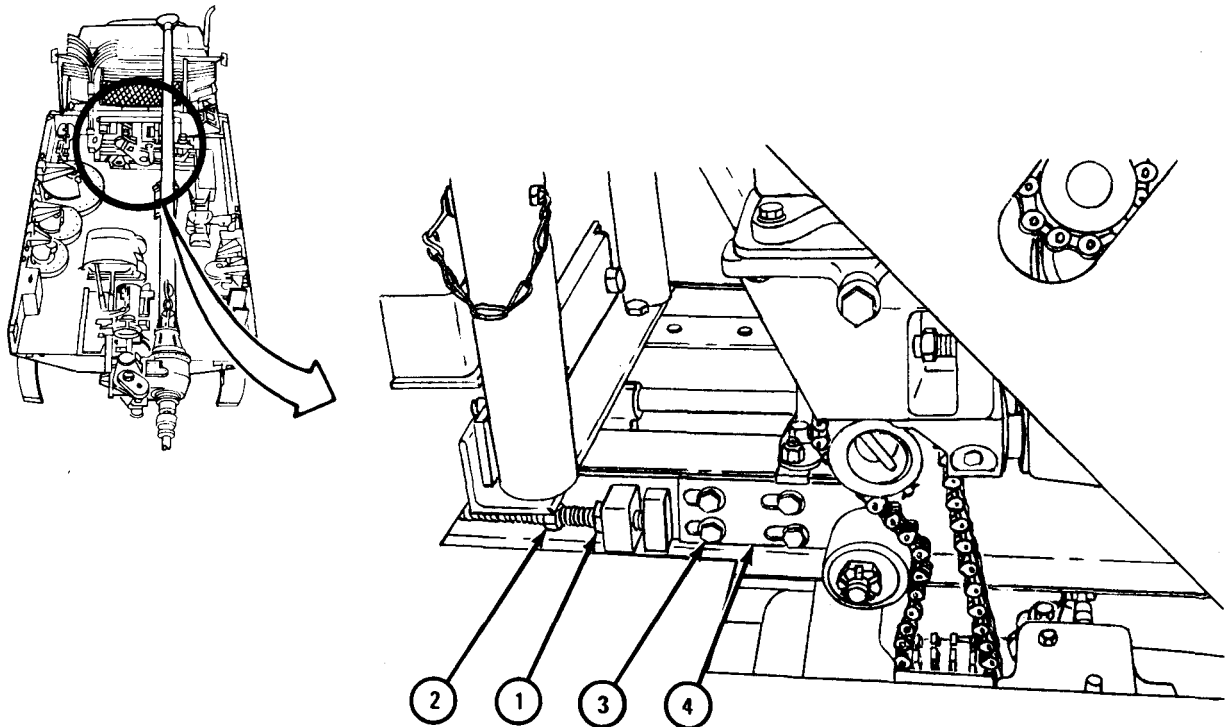

TA 088495

FRAME

4

1. Takeout cotter pin (1) from end of control rod assembly (2).
2. Take pin (3) out of rod end (4).
3. Take control rod assembly (2) off power divider shifter shaft (5). Let control rod assembly hang down.

GO TO FRAME 5

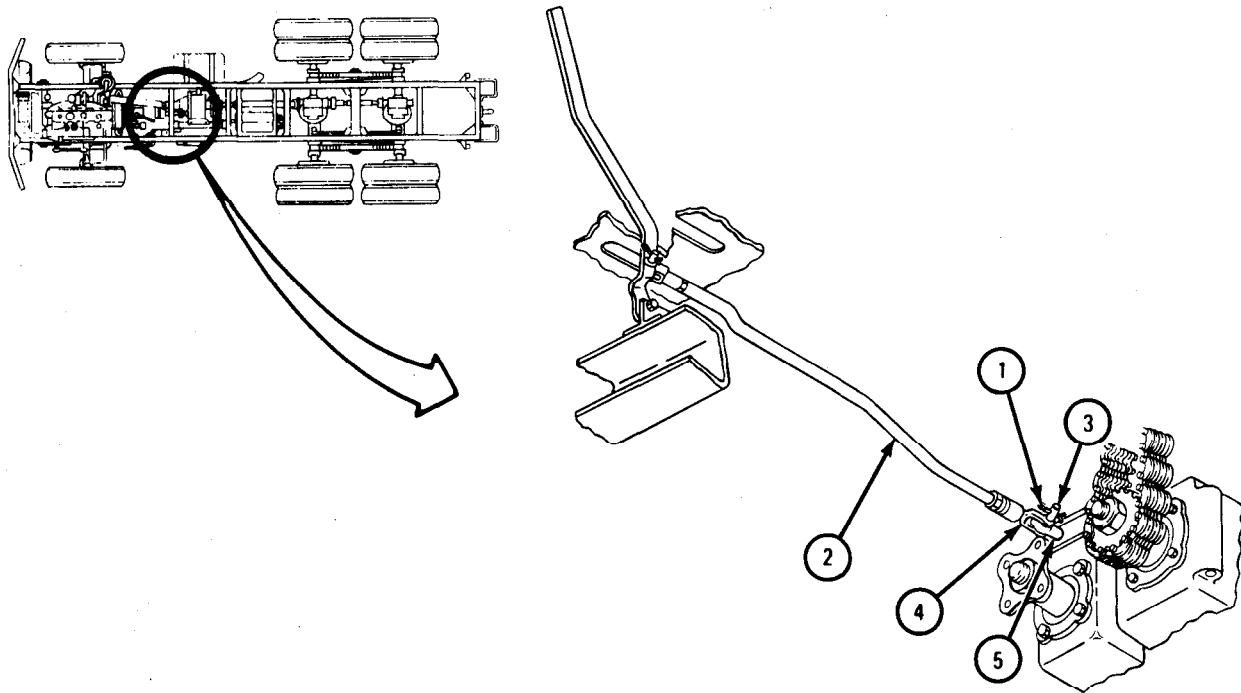

TA 088496

FRAME 5

- Soldier A 1. Hook hoist to lower portion of power divider (1).
 2. Take out four capscrews and washers (2).

NOTE

If chain (3) has a master link, take off chain.

3. Lower rear portion of power divider (1) slowly to clear chain (3) from gear (4).
 Soldier B 4. Working from above power divider (1), pull chain (3) out of the way.
 Soldier A 5. Lower power divider (1) to ground.

END OF TASK

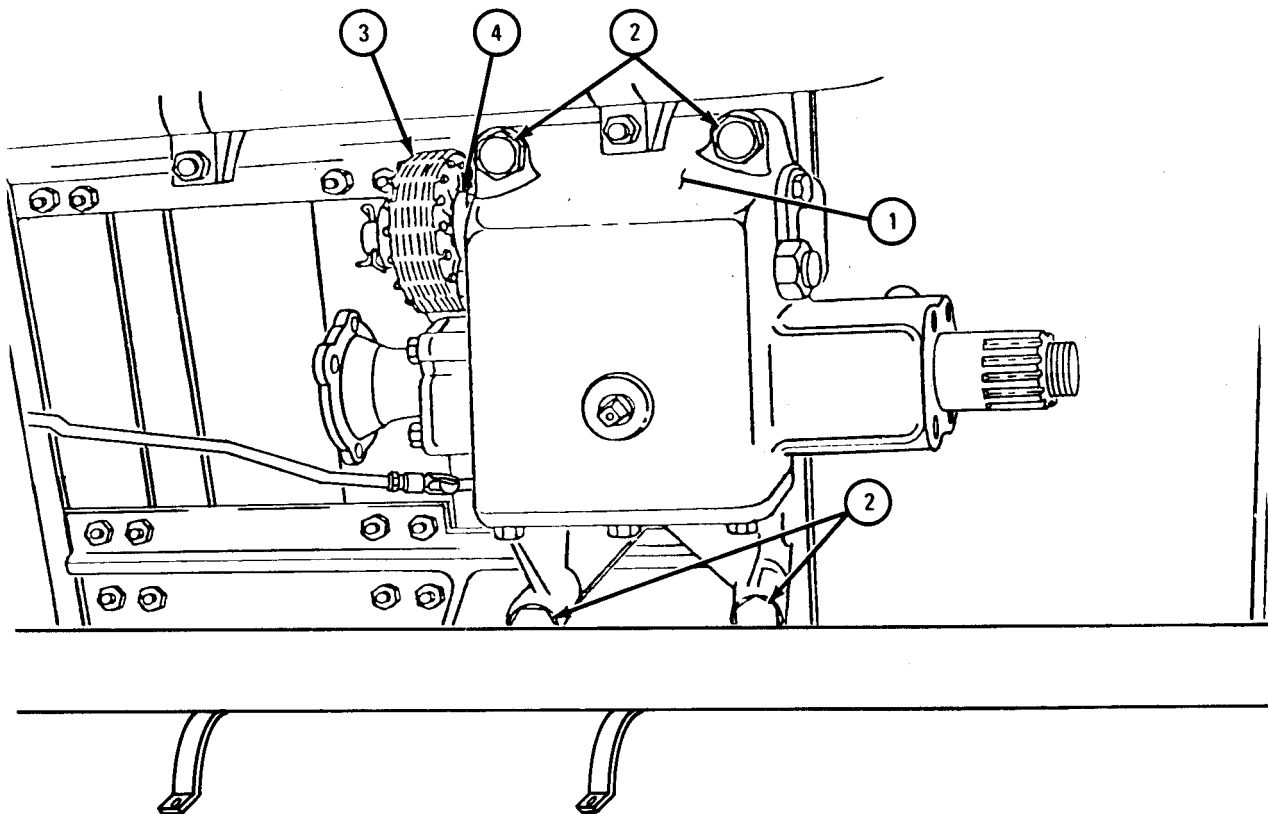

TA 088497

c. Disassembly.

FRAME 1

1. Take out plug (1) and drain oil from housing (2) into container.
2. Take out eight capscrews (3) and washers (4) from housing cover (5).
3. Take off cover (5) from pins (6) in housing (2).
4. Take out and throw away cover gasket (7).
5. Take out valve (8) with two bushings (9).

GO TO FRAME 2

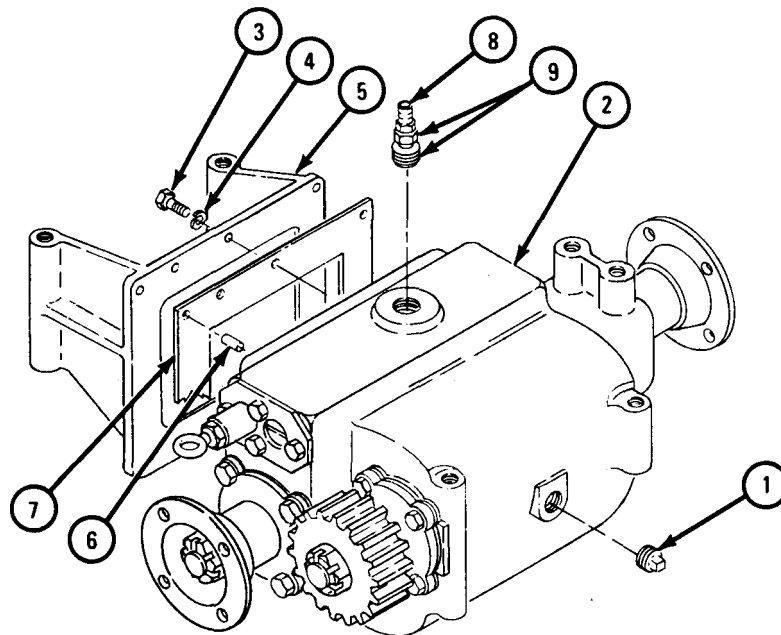

TA 088498

FRAME 2

NOTE

Be sure that shifting rod (1) is meshed in third notch of shifter shaft (2).

1. Place shifting rod (1) in third notch of shifter shaft (2). If needed, screw in shifter shaft until shifting rod catches shaft.
2. Take out cotter pin (3) and loosen nut (4) holding flange (5) on shaft assembly (6).
3. Take out four capscrews (7) and washers (8).
4. Loosen bearing cap (9) from housing (10) by pulling on flange (5).
5. Take out shaft assembly (6). Be careful not to lose or damage shims (11).

GO TO FRAME 3

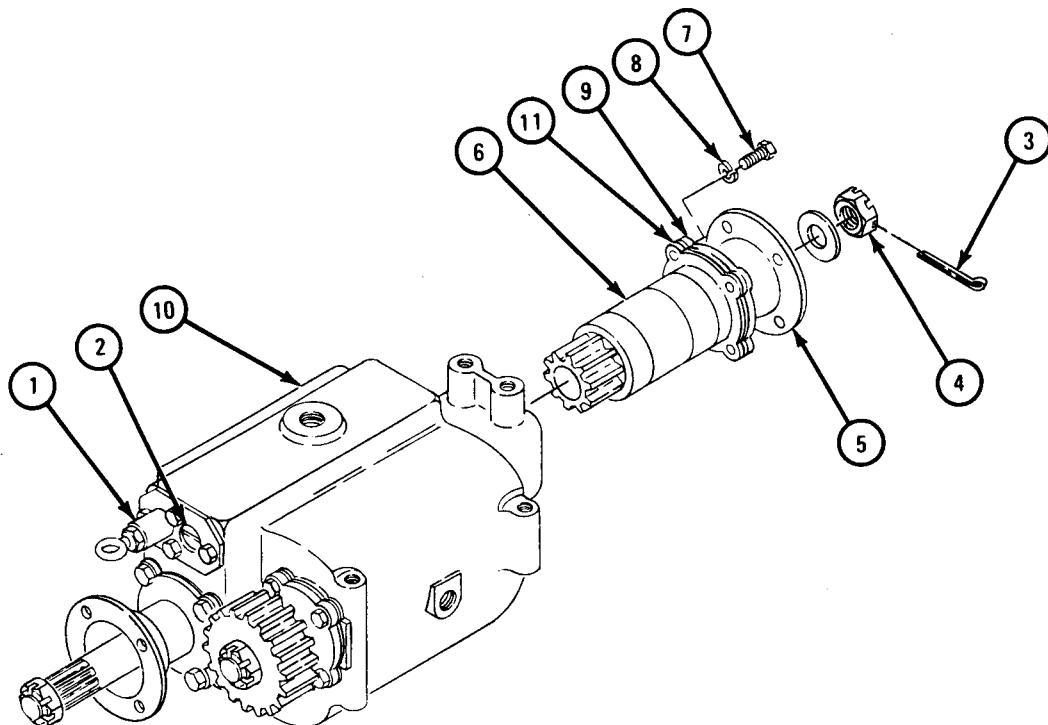

TA 088499

FRAME 3

1. Takeoff nut (1) and washer (2).
2. Take off flange (3) from shaft (4).
3. Take off bearing cap (5) with seal (6), shims (7), and bearing (8). Note thickness of shims.

NOTE

Do not take out seal (6) from bearing cap (5) unless it is damaged. Refer to para 18-12e for inspection procedures.

4. Take off seal (6) from cap (5).

GO TO FRAME 4

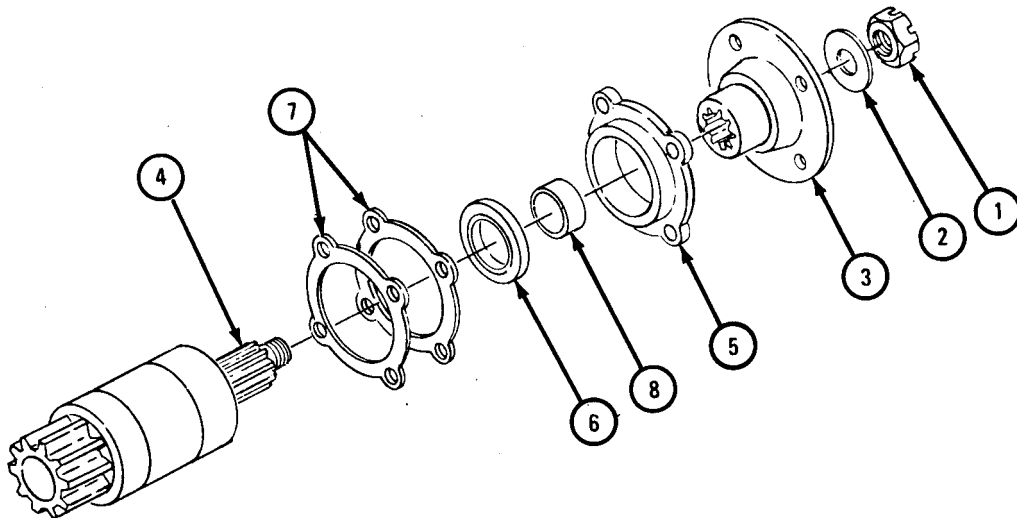

TA 088500

FRAME 4

1. Take bearing (1) off shaft (2).
2. Takeout spacer (3), bearing sleeve (4), and bushing (5).
3. Take bearing (6) off shaft (2).
4. Pull outer race and rollers of roller bearing (7) from shaft (2).

NOTE

Inner race of roller bearing (7) will stay on shaft (8).

GO TO FRAME 5

FRAME 5

1. Take out cotter pin (1) and loosen nut (2).
2. Take out four capscrews (3) and washers (4).
3. Loosen bearing cap (5) from housing (6) by pulling on flange (7).
4. Take out shaft assembly (8) by pulling on flange (7) with one hand while holding sliding gear (9) with the other.
5. Take gear (9) out of housing (6).

GO TO FRAME 6

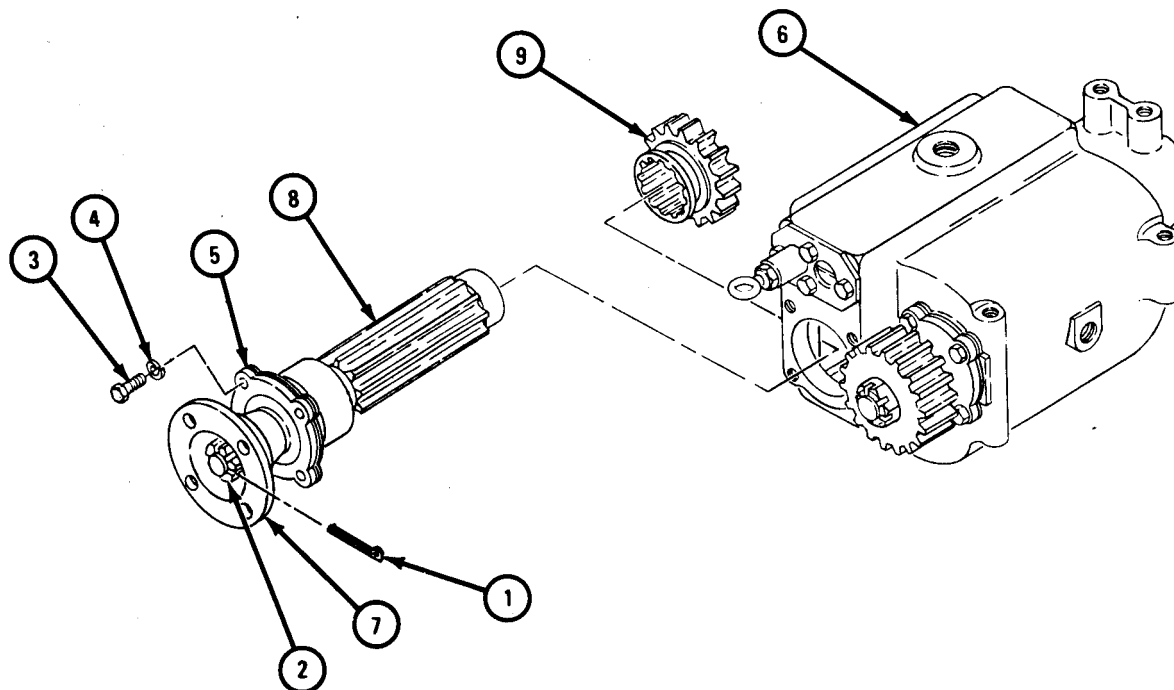

TA 088902

FRAME 6

1. Take off nut (1) and washer (2).
2. Take flange (3) off shaft (4).
3. Take off bearing cap (5) with seal (6), shims (7), and bearing (8). Note thickness of shims.

NOTE

Do not take out seal (6) from bearing cap (5) unless it is damaged. Refer to para 18-12e for inspection procedures.

4. Take out seal (6) from bearing cap (5).

GO TO FRAME 7

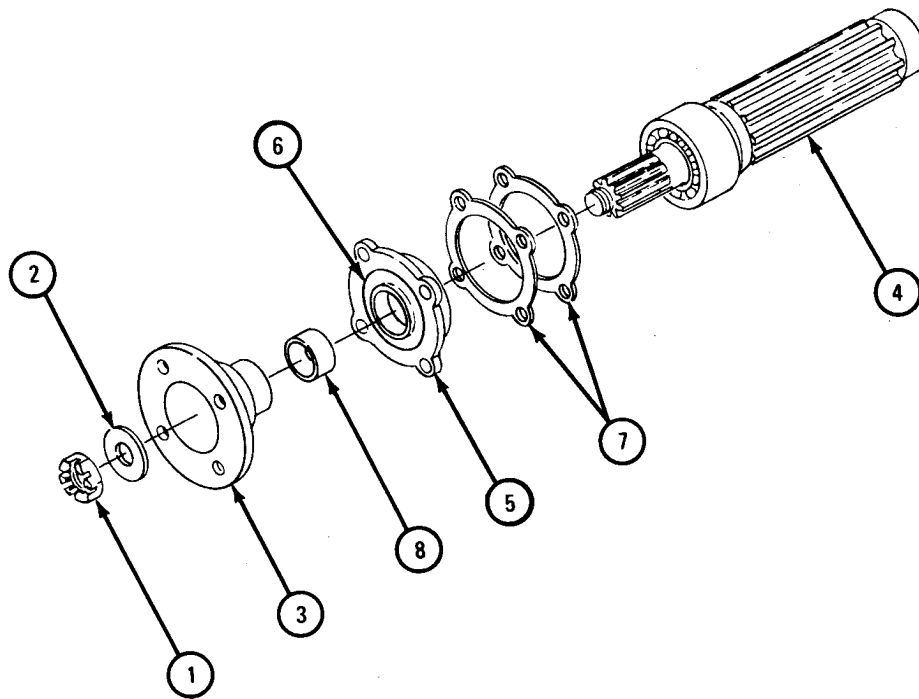

TA 088903

FRAME 7

1. Press bearing (1) off shaft (2).
2. Take spacer (3) off shaft (2).

NOTE

Do not take out bearing inner race (4) on end of shaft (2) unless it is damaged, Refer to para 18-12e for inspection procedures.

3. Take bearing inner race (4) off shaft (2).

GO TO FRAME 8

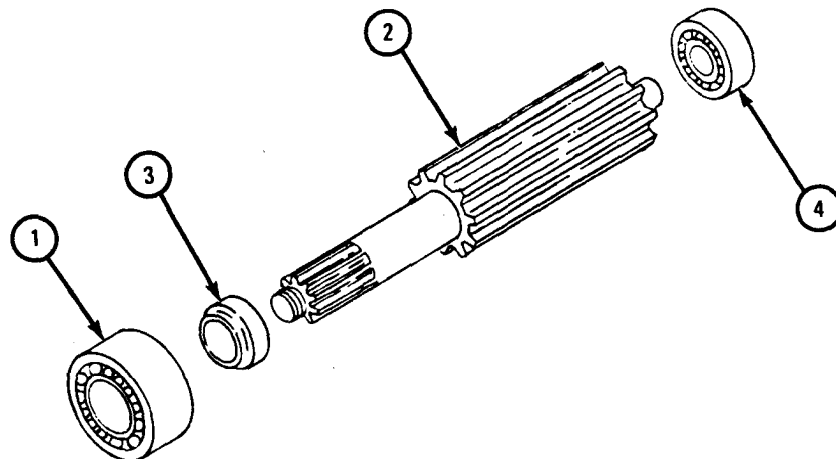

TA 088904

FRAME 8

NOTE

Before taking out shifter rod (1), note distance end of shifter rod sticks out from packing plate (2).

1. Move shifter rod (1) to catch the third detent from front of shifter shaft (3).
2. Unscrew shifter rod (1) from shifter fork (4). Take off washer (5) and nut (6).

GO TO FRAME 9

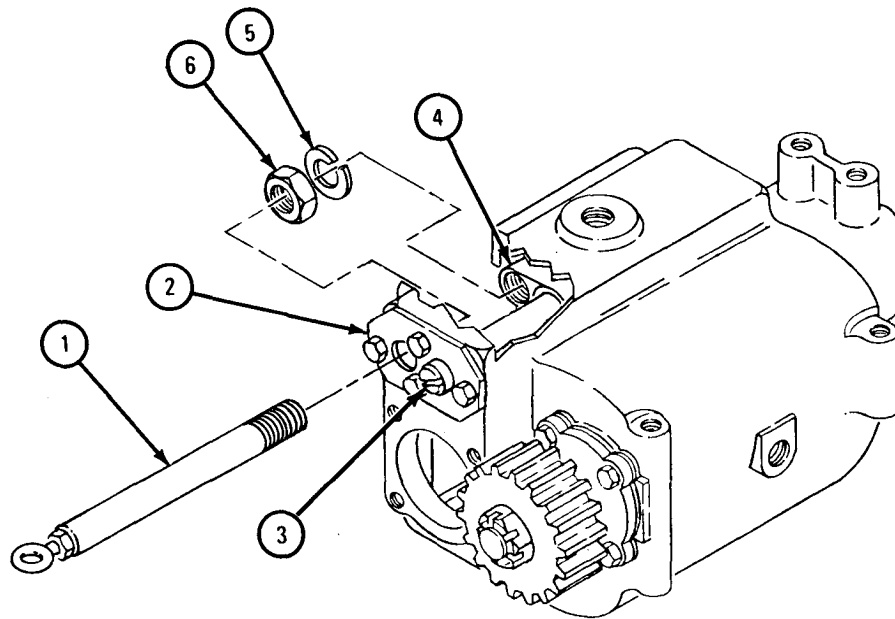

TA 088905

FRAME 9

NOTE

Before taking out shifter shaft (1), note distance end of shaft sticks out from packing plate (2). Note position of slot in shaft.

1. Take off nut (3) from shifter shaft (1).
2. Unscrew shifter shaft (1) from housing (4).
3. Pull out shifter shaft (1) with one hand while holding shifter fork (5) with the other. Be careful not to lose detent (6) and spring (7) in shifter fork.
4. Take out four capscrews (8) and washers (9).
5. Take out packing (10) from housing (4). Be careful not to damage packing.

GO TO FRAME 10

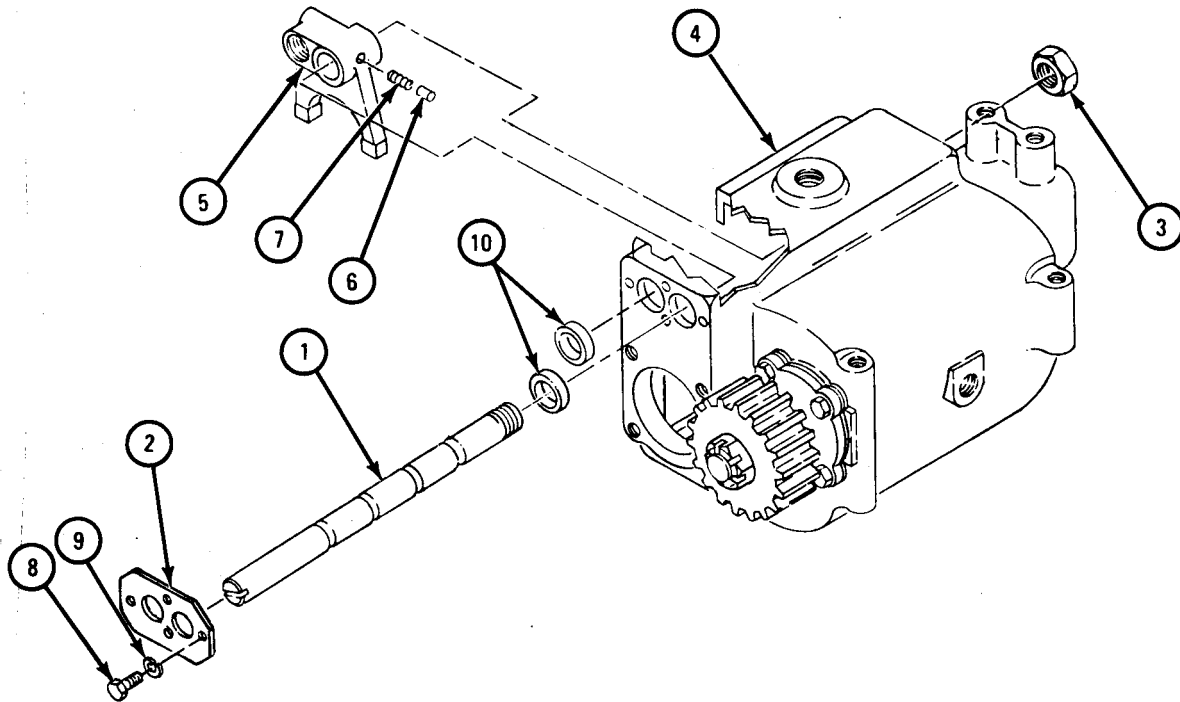

TA 088906

FRAME 10

1. Take out two cotter pins (1) and nuts (2) from shaft (3).
 2. Take out shaft (3) with one hand while holding idler gear (4) and two washers (5) with the other.
 3. Take out idler gear (4) and two washers (5) from housing (6).
- GO TO FRAME 11

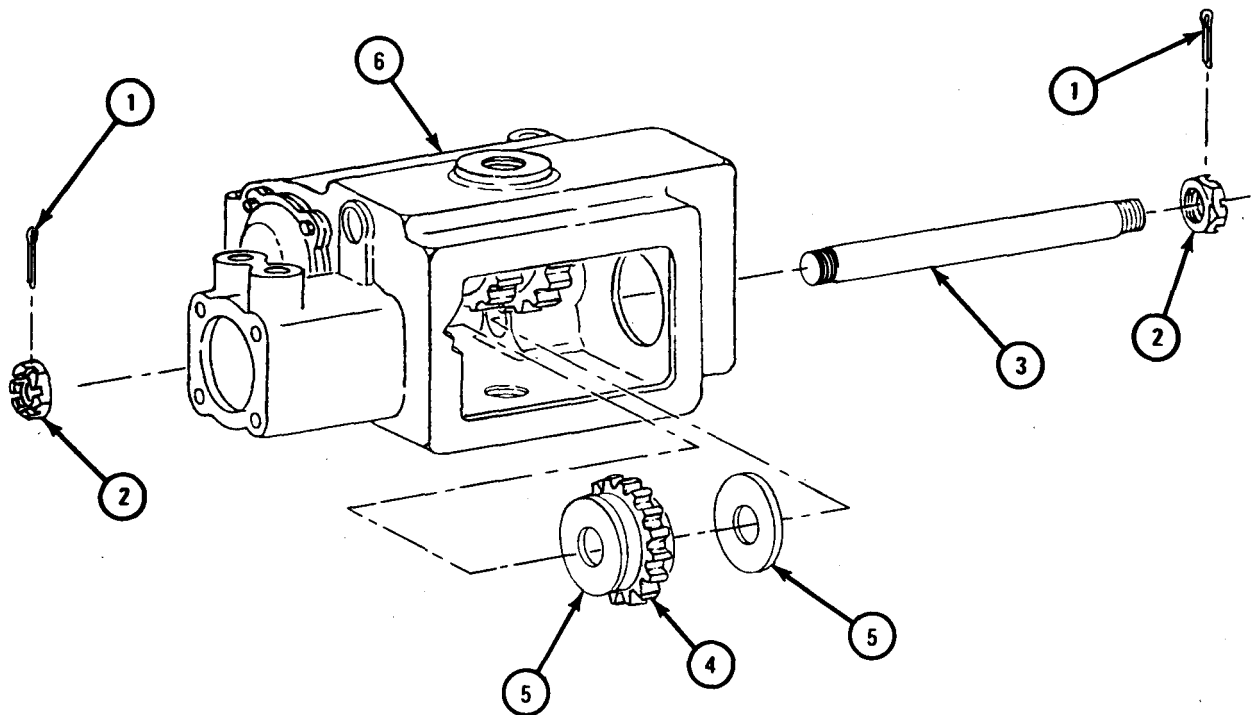

TA088907

FRAME 11

1. Take idler gear (1) off two bearings (2).
2. Take off outer race and roller portion of two bearings (2).
3. Take off outer bearing spacer (3).

NOTE

Do not take off inner race of bearings (2) and inner bearing spacer (4) unless they are damaged.

4. Press off inner races of two bearings (2) and take out inner bearing spacer (4) from bearing sleeve (5).

GO TO FRAME 12

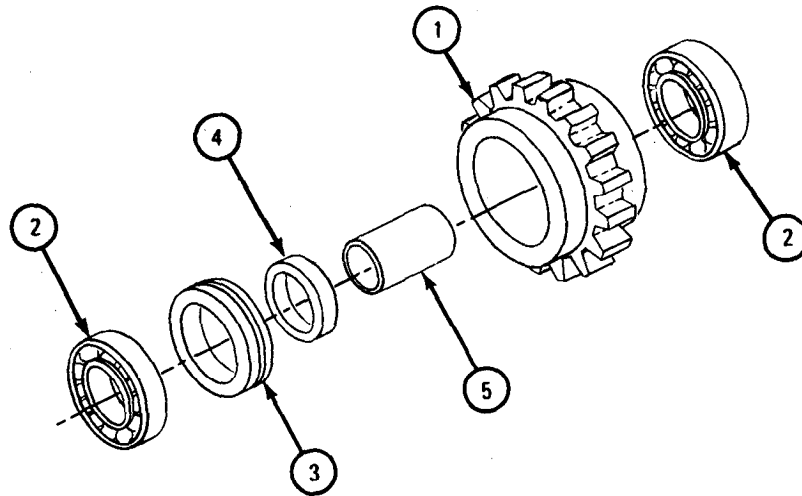

TA088908

FRAME 12

1. Take out cotter pin (1).
2. Take nut (2) and washer (3) off of shaft (4).
3. Pull gear (5) from shaft (4). Take out key (6).

GO TO FRAME 13

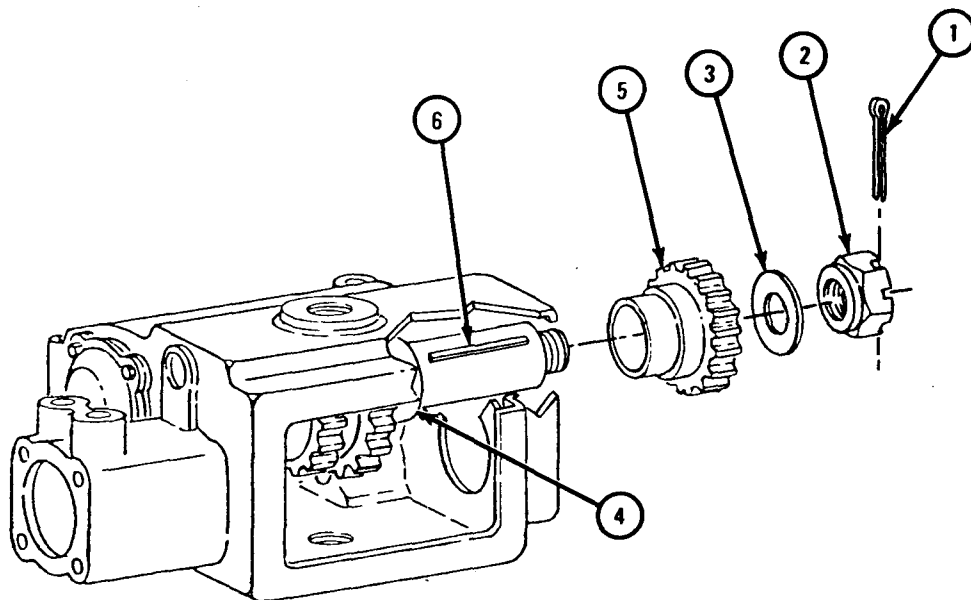

TA088909

FRAME 13

1. Take out four capscrews (1) and washers (2) holding bearing cap (3) to housing (4).
2. Take off bearing cap (3) with seal (5) and shims (6). Note thickness of shims.

NOTE

Do not take out seal (5) unless it is damaged. Refer to para 18-12e for inspection procedures.

3. Take out seal (5).

GO TO FRAME 14

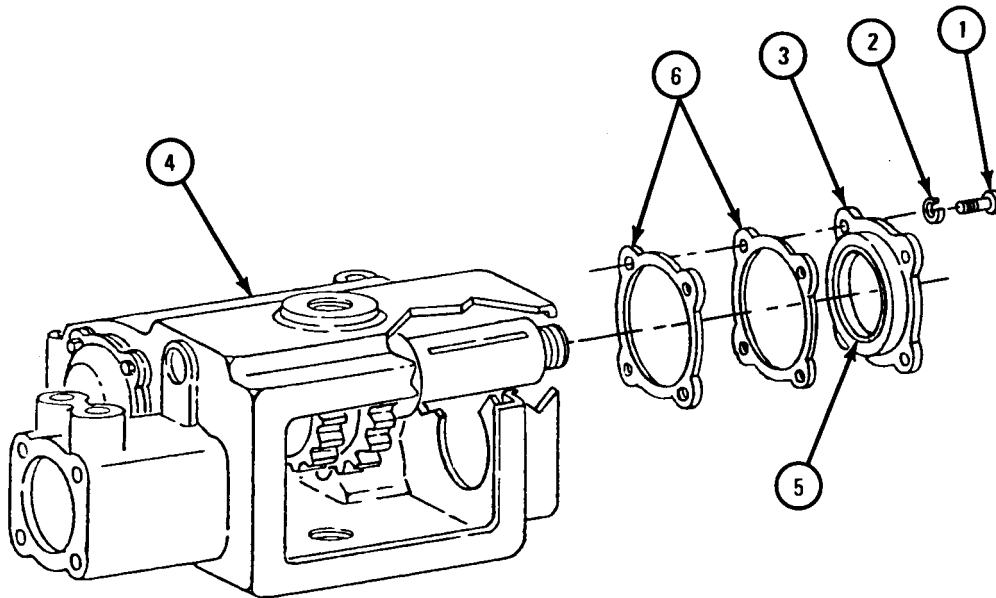

TA088910

FRAME 14

1. Take out four capscrews (1) and washers (2).
2. Take off bearing cap (3) from housing (4).
3. Take out cotter pin (5) and nut (6) from shaft (7).

GO TO FRAME 15

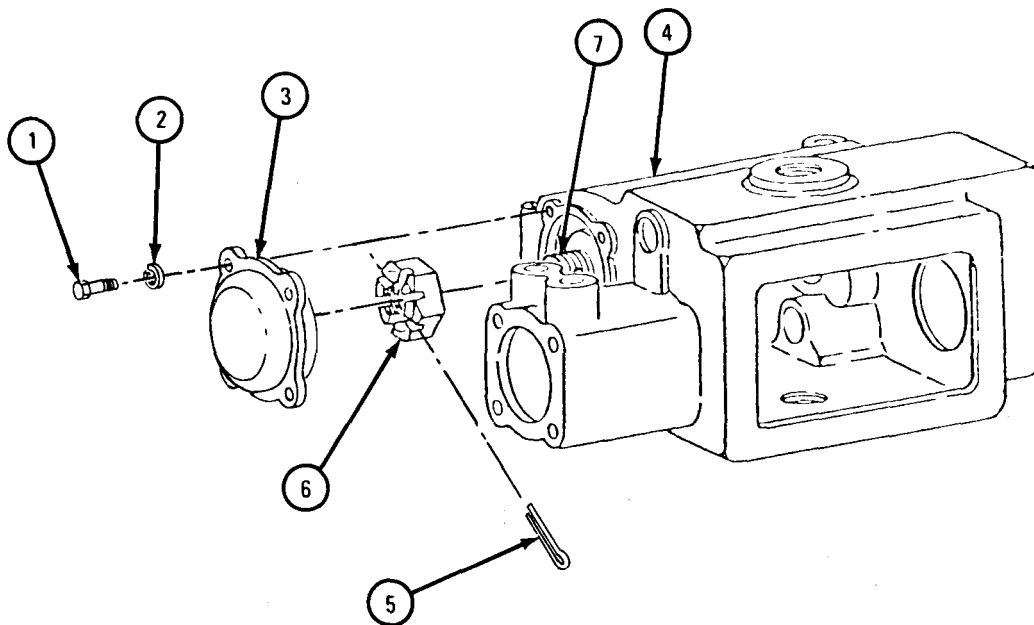

TA 088911

FRAME 15

CAUTION

When taking out shaft (1), use a ram smaller than diameter of threads to protect threads and inner race of bearings (2 and 3).

1. Hold gear end of shaft (1) to stop damage to gears (4 and 5) when bearings (2 and 3) come out of housing (6).
2. Press gear end of shaft (1) until bearings (2 and 3) are free of housing (6).
3. Move shaft (1) to the left until teeth of gear (5) touch inside of housing (6).
4. While holding shaft (1) with one hand, press shaft free of bearing (2) and gears (4 and 5).
5. Take out shaft (1) with bearing (3) and key (7) from housing (6).
6. Take out key (7) and take off bearing (3) from shaft (1).
7. Take out bearing (2) and gears (4 and 5) from housing (6).

END OF TASK

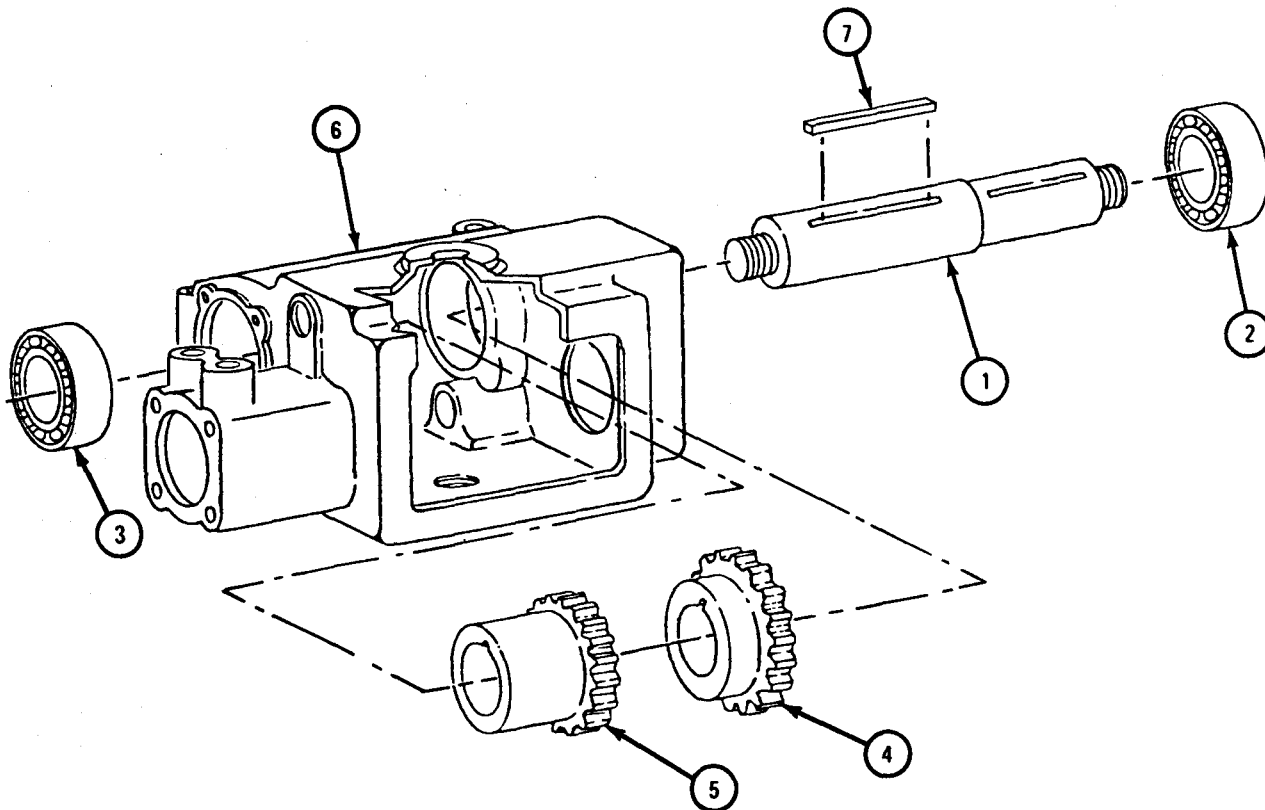

TA 088912

d. Cleaning. There are no special cleaning procedures needed. Refer to cleaning procedures given in Part 1, para 1-3.

NOTE

Clean all parts before inspection and before assembly.

e. Inspection and Repair.

FRAME 1

1. Check that shafts (1 through 6) have no cracks or distortion. Use magnaflux if available. If shafts are cracked or damaged, get new ones.
2. Check that all machined surfaces and threads are not worn or damaged. If parts are damaged, get new ones.
3. Check that splines on shafts (3 and 6), flanges (7 and 8), and sliding gear (9) are not worn, scored, burred, bent, twisted or rough. Raised metal, nicks or scratches must be taken off with honing stone and shafts polished using crocus cloth. If more repair is needed, get new parts.
4. Check that splines on shafts (3 and 4), flanges (7 and 8), and sliding gear (9) join together and move easily with one another. Minor damage can be smoothed with a honing stone, then polished with a crocus cloth. If more repair is needed, get new parts.

GO TO FRAME 2

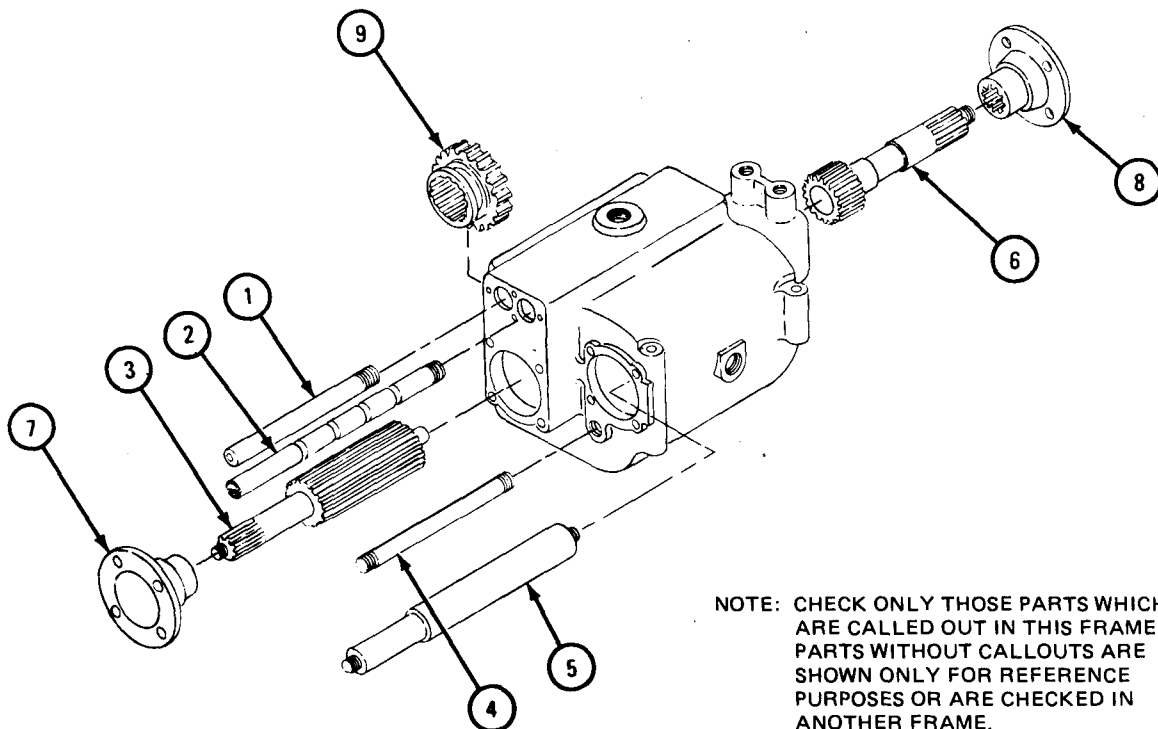

NOTE: CHECK ONLY THOSE PARTS WHICH ARE CALLED OUT IN THIS FRAME. PARTS WITHOUT CALLOUTS ARE SHOWN ONLY FOR REFERENCE PURPOSES OR ARE CHECKED IN ANOTHER FRAME.

TA 088913

FRAME 2

1. Check that teeth on gears (1 through 5) are not chipped or broken. If gears have chipped or broken teeth, get new ones.
2. Check that gears (1 through 5) have no cracks. Use magnaflux if available. If gears are cracked, get new ones.
3. Check that gears (1 through 5) are not pitted, nicked, scored or burred. Repair minor damage using a honing stone. If more repair is needed, get new gears.

GO TO FRAME 3

NOTE: CHECK ONLY THOSE PARTS WHICH ARE CALLED OUT IN THIS FRAME. PARTS WITHOUT CALLOUTS ARE SHOWN ONLY FOR REFERENCE PURPOSES OR ARE CHECKED IN ANOTHER FRAME.

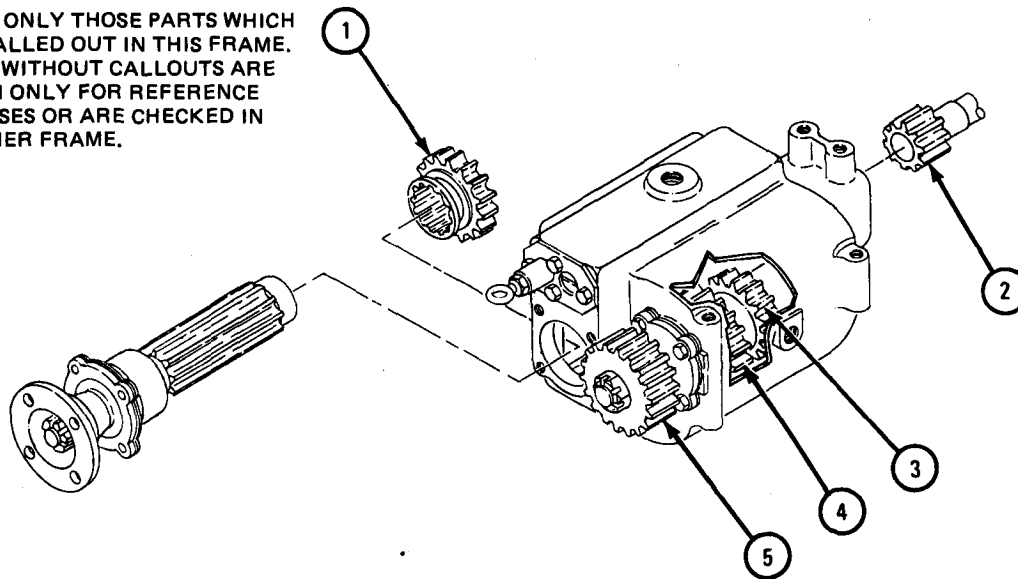

TA 088914

FRAME 3

1. Check that gear (1) has no sharp fins or burrs at tooth corners. If gear is worn or damaged, get a new one.
2. Check that teeth on gear (1) are not chipped or broken. If gear has chipped or broken teeth, get a new one.
3. Check that gear (1) has no cracks. Use magnaflux if available. If gear is cracked, get a new one.
4. Check that tooth faces of gear (1) have no nicks, scores, burrs, galling or pitting. Repair damage using a honing stone. If more repair is needed, get a new gear.
5. Measure thickness of thrust washers (2 and 3). The thickness of a new washer is 0.120 to 0.125 inch and wear limit is 0.105 to 0.110 inch. If thickness is not within given limits, get a new thrust washer.

GO TO FRAME 4

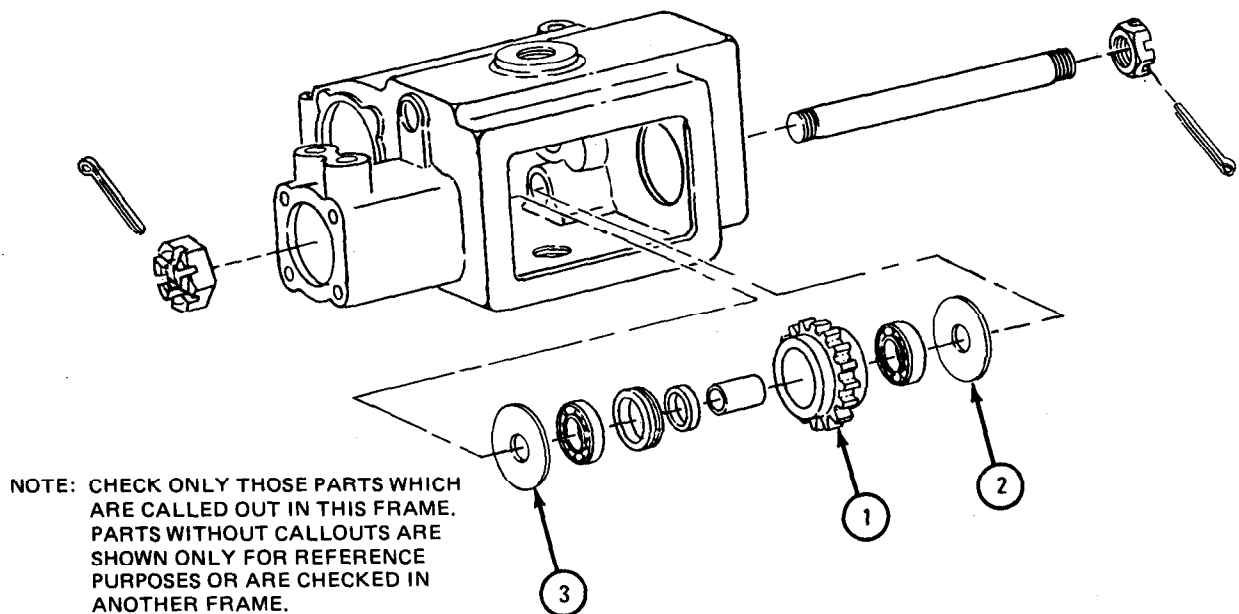

TA 088915

FRAME 4

1. Put a coat of clean oil on bearings (1 through 7), Turn each bearing slowly by hand. Each bearing must turn smoothly and freely without binding. If bearings are damaged, get new ones.
2. Check that ball bearings (1 through 6) and two roller bearings (7) have no pitting, wear or any other damage. If bearings are worn or damaged, get new ones.
3. Check that bearing cages have no cracks or other damage. If bearing cages are worn or damaged, get new bearings.

GO TO FRAME 5

NOTE: CHECK ONLY THOSE PARTS WHICH ARE CALLED OUT IN THIS FRAME. PARTS WITHOUT CALLOUTS ARE SHOWN ONLY FOR REFERENCE PURPOSES OR ARE CHECKED IN ANOTHER FRAME.

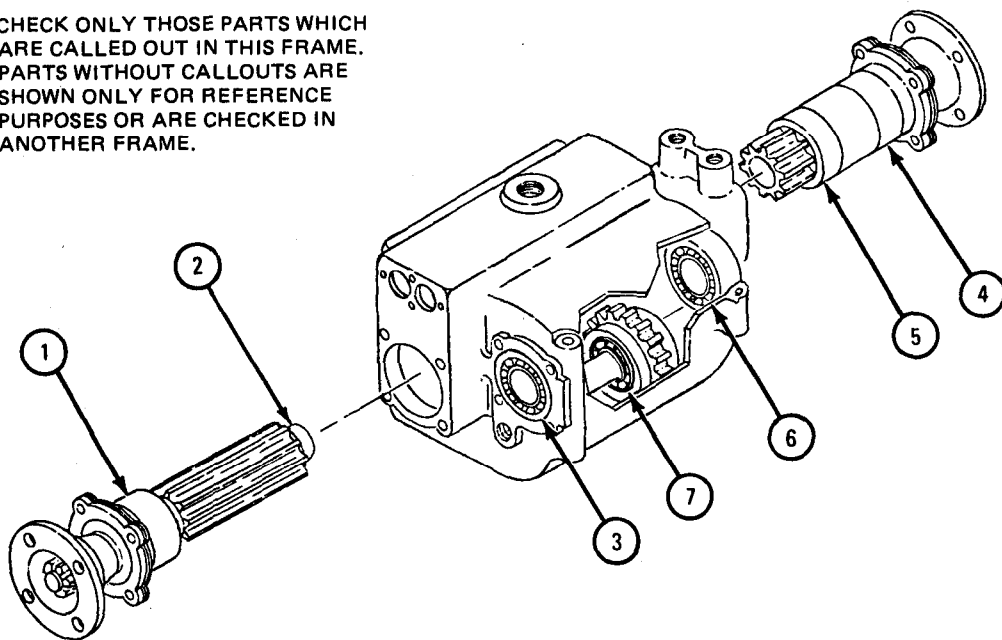

TA 088916

FRAME 5

1. Check that seals (1, 2, and 3) have no oil leaks. If seals have oil leaks, get new ones.
2. Check that seals (1, 2, and 3) have no stiff, dry or burned rubber. If rubber is damaged, get new seals.
3. Check that sharp edge of seals (1, 2, and 3) is not broken, torn or damaged in any other way. If edges of seals are damaged, get new seals.
4. Check that packings (4 and 5) are not worn, torn or burned. If packings are damaged, get new ones.
5. Check that packings (4 and 5) are not stiff and that sealing contact of packings has no gaps. If packings are stiff or do not make sealing contact, get new packings.

END OF TASK

**NOTE: PARTS WITHOUT CALLOUTS
ARE SHOWN ONLY FOR
REFERENCE PURPOSES.**

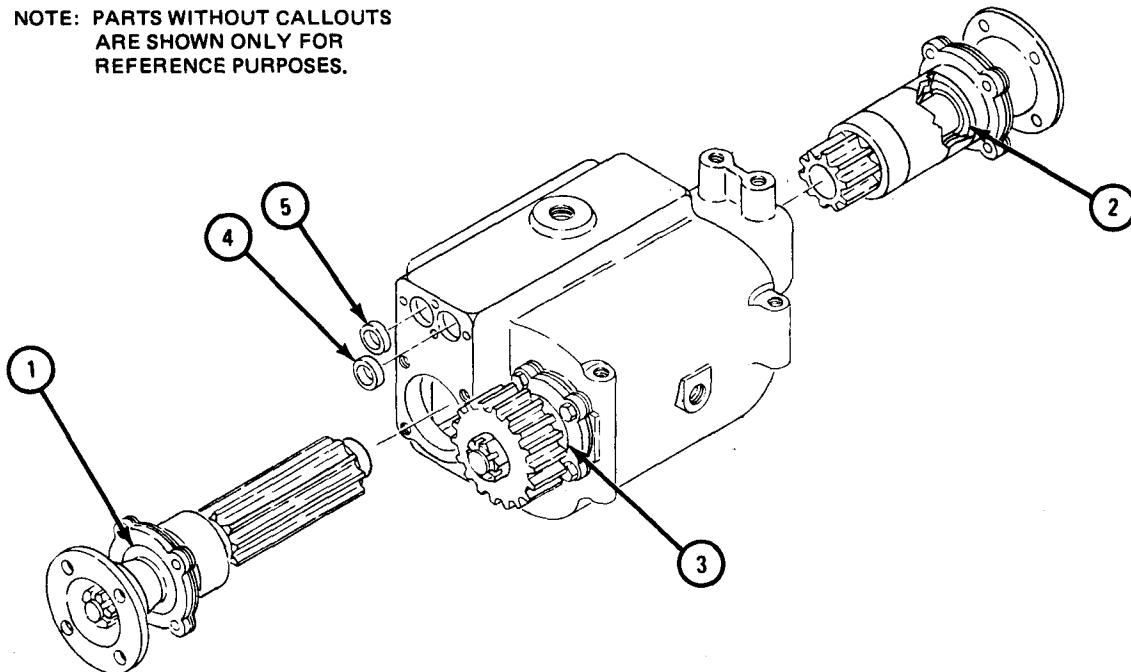

TA 088917

f. Assembly.

FRAME 1

1. Put bearing (1) on shaft (2) with 3/4 inch between nut side of bearing and threaded end of shaft.
2. Put nut (3) on shaft (2) against bearing (1).
3. Put in cotter pin (4).

CAUTION

Make sure that end of key (5) is not touching inner race of bearing (1).

4. Put key (5) into keyway of shaft (2).
5. Place gears (6 and 7) inside housing (8) as shown.
6. Put shaft (2) into housing (8). Align key (5) in shaft (2) with keyway in gears (6 and 7). Tap nut end of shaft (2) with soft-faced hammer until bearing (1) goes into housing (8).

NOTE

Position shaft (2) in housing (8) so that front side of gear (7) is seated against housing.

7. Tap shaft (2) to seat bearing (1) against nut (3).

GO TO FRAME 2

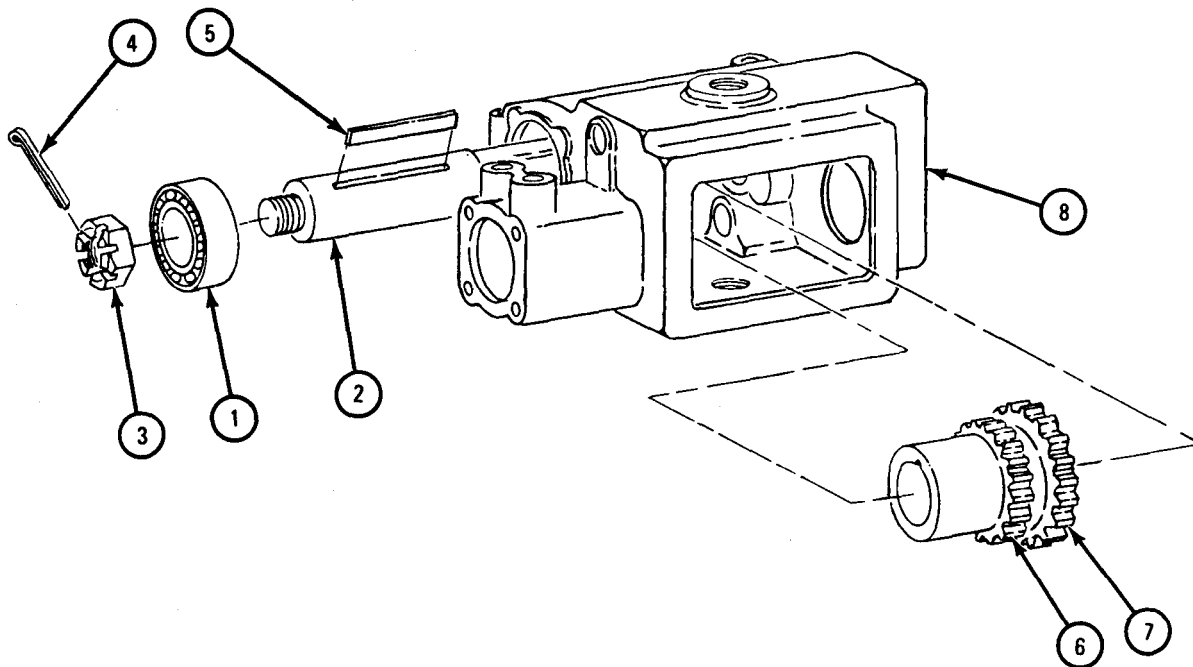

FRAME 2

1. Put bearing (1) on shaft (2) with bearing against gear (3).
2. Put bearing cap (4) on housing (5). Put in four capscrews and washers (6).

NOTE

Lip of seal (7) must face in toward housing (5) and casing must be flush with outside of bearing cap (8).

3. If oil seal (7) was taken out, put in new seal.
4. Put bearing cap (8) with seal (7) and shims (9) as noted on housing (5). Put in four capscrews and washers (10).

GO TO FRAME 3

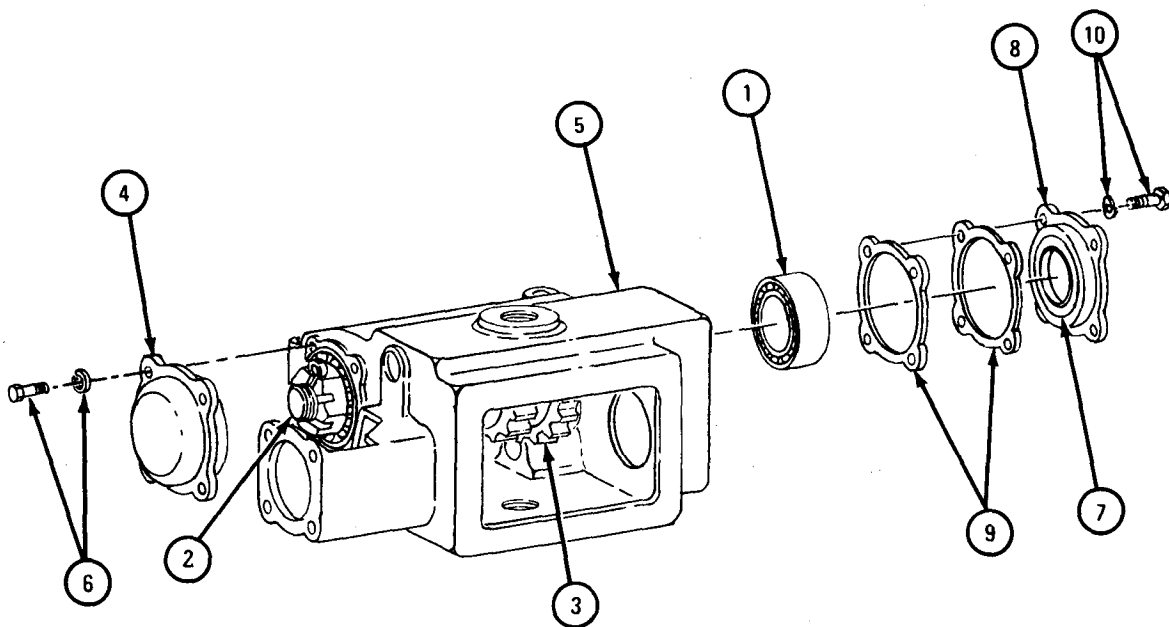

TA 088919

FRAME 3

1. Put key (1) in keyway of shaft (2).
2. Align keyway in sprocket (3) with key (1). Tap sprocket (3) over key until end of sprocket touches inner race of bearing (4).
3. With end of sprocket (3) against bearing (4), tap sprocket end of shaft (2) to make sure that other bearing is seated against bearing cap (5).
4. Put washer (6) and nut (7) on shaft (2).

NOTE

End play is the amount that shaft moves from end to end or side to side.

5. Check that shaft (2) has only 0.005 inch end play. If needed, take off bearing cap (9) and add or take off shims (10) until end play is 0.005 inch.
6. Put in cotter pin (8).

GO TO FRAME 4

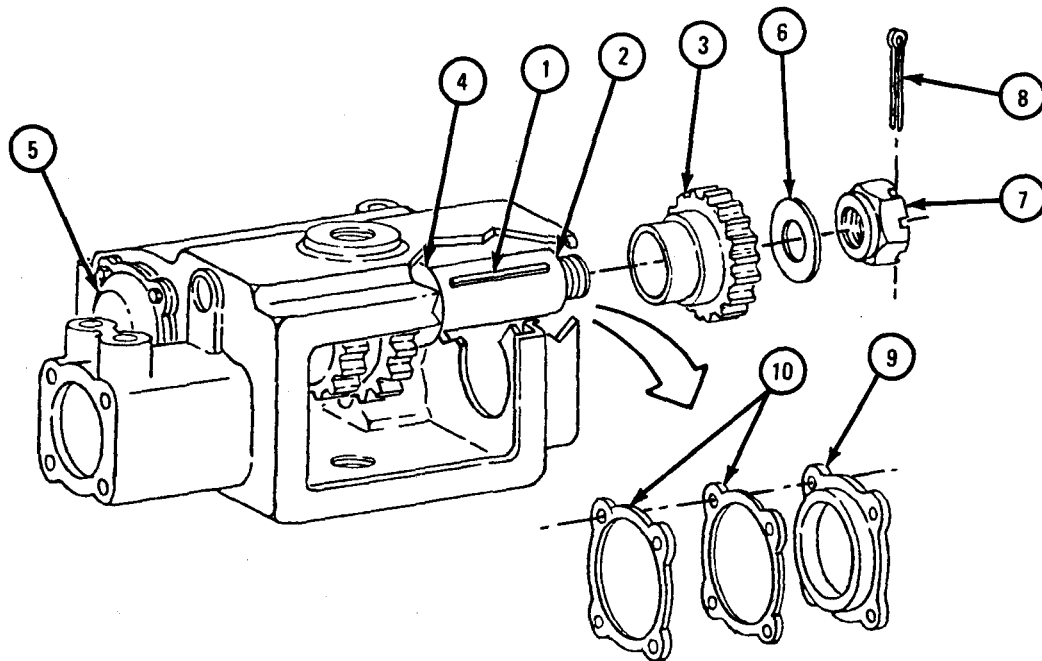

TA 088920

FRAME 4

1. If inner faces of bearings (1 and 2) were taken off shaft bearing sleeve (3), press in new inner races. Place inner bearing spacer (4) between two inner races.

NOTE

Make sure that each inner race of bearings (1 and 2) is the same distance from end of bearing sleeve (3).

2. Put gear (5) over bearing spacer (4).
3. Put outer bearing spacer (6) and outer race and roller portion of bearings (1 and 2) in gear (5).

GO TO FRAME 5

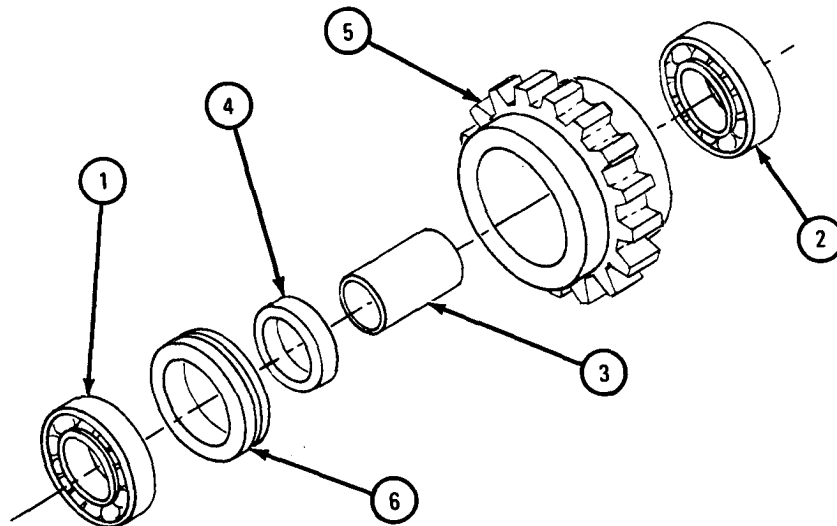

TA 088921

FRAME 5

1. Put thrust washer (1) on each side of gear (2) and put gear assembly between two bosses inside housing (3).
2. Holding gear (2) and thrust washers (1) with one hand, put shaft (4) through housing (3).
3. Put two nuts (5) on shaft (4).
4. Put two cotter pins (6) through nuts (5).

GO TO FRAME 6

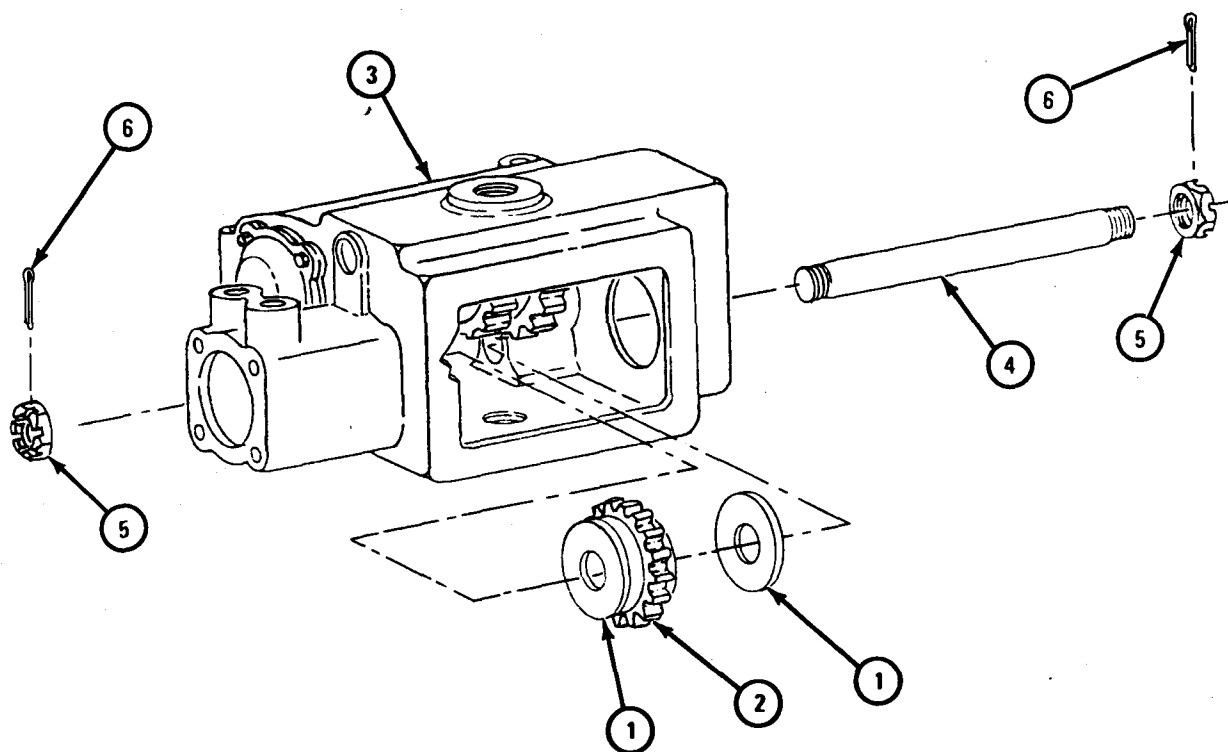

TA088922

FRAME 6

1. Put spring (1) and detent (2) in shifter fork (3) and hold them in place.
2. Put shifter fork (3) with detent (2) on sliding gear (4) and put them in housing (5).
- Soldier A 3. Using pry bar, squeeze spring (1) and detent (2).
- Soldier B 4. Put in shaft (6) threaded end first, through housing (5) and shifter fork (3). Thread shaft into rear of housing. Take out gear (4).
5. Soak packing (7) with oil. Put packing over shaft (6) and seat it in housing (5).

GO TO FRAME 7

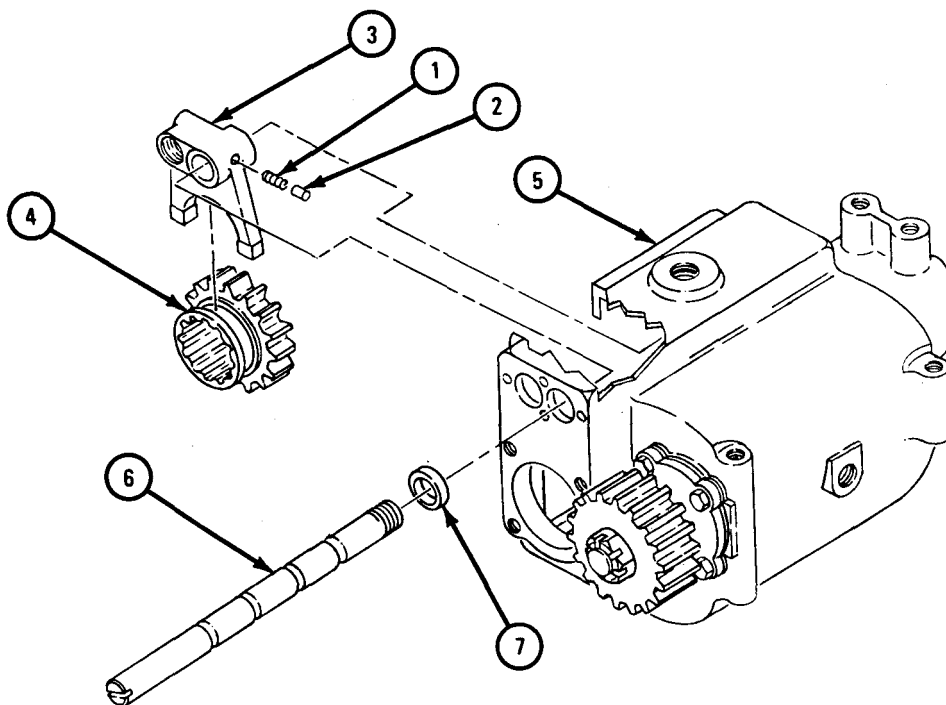

TA 088923

FRAME 7

1. Put threaded end of shifter rod (1) through housing (2).
2. Put nut (3) and washer (4) on shifter rod (1).
3. Thread shifter rod (1) into side of shifter fork (5).
4. Soak packing (6) with oil. Put packing over shifter rod (1) and seat it in housing (2).
5. Put packing plate (7) in place on housing (2) and put in four capscrews and washers (8).
6. Move end of shifter shaft (9) out from packing plate (7) to distance noted. Make sure slot in shaft is positioned as noted.
7. Put on nut (10) on end of shifter shaft (9).
8. Move shifting rod (1) in shifter fork (5) out from packing plate (7) to distance noted.
9. Tighten nut (3) with washer (4) on shifter rod (1) against shifter fork (5).

GO TO FRAME 8

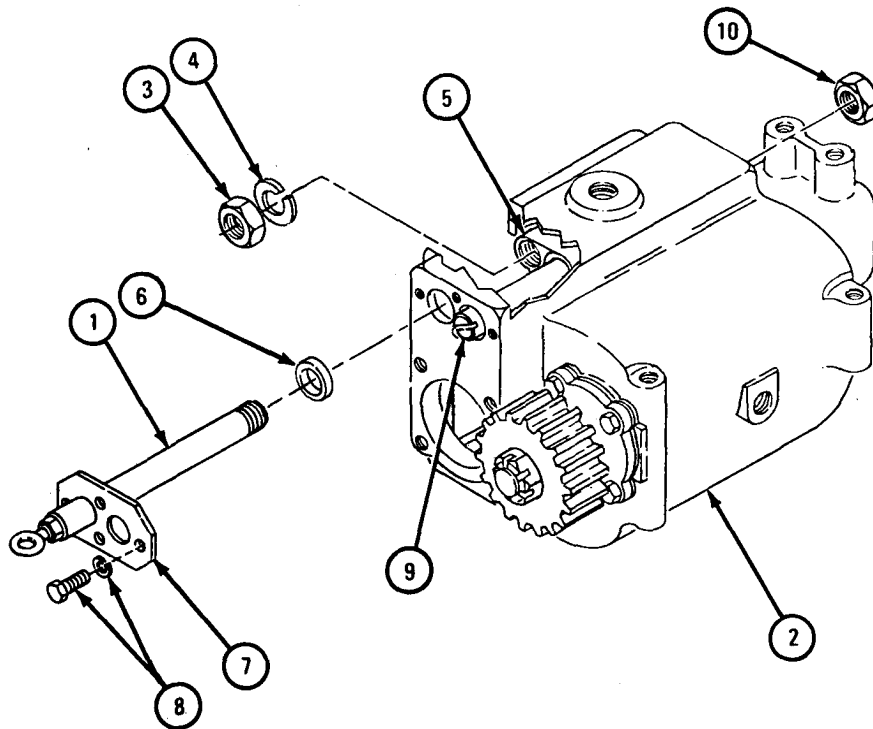

TA 088924

FRAME 8

1. Put bearing spacer (1), larger end first, on shaft (2).
2. Press bearing (3) on shaft (2) flush against bearing spacer (1).

NOTE

Make sure that inner race of bearing (4) is against shoulder of shaft (2).

3. If the inner race of bearing (4) was taken off, press on new inner race and bearing on end of shaft (2).

GO TO FRAME 9

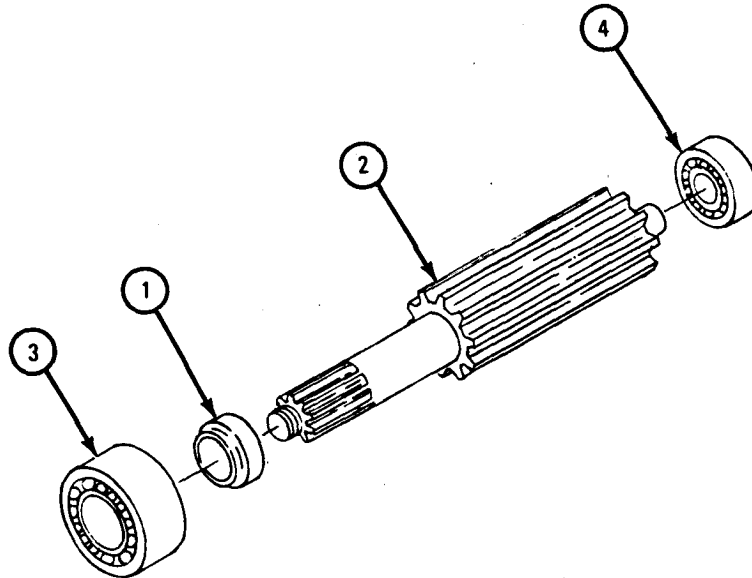

TA 088925

FRAME 9

1. Put bearing (1) onto shaft (2). Make sure that bearing is against gear portion of shaft .
2. Put bushing (3) and spacer (4) on shaft (2).
3. Put bearing sleeve (5) on shaft (2).
4. Put bearing (6) over bearing sleeve (5). Make sure that bearing is against bushing (3) and spacer (4).

GO TO FRAME 10

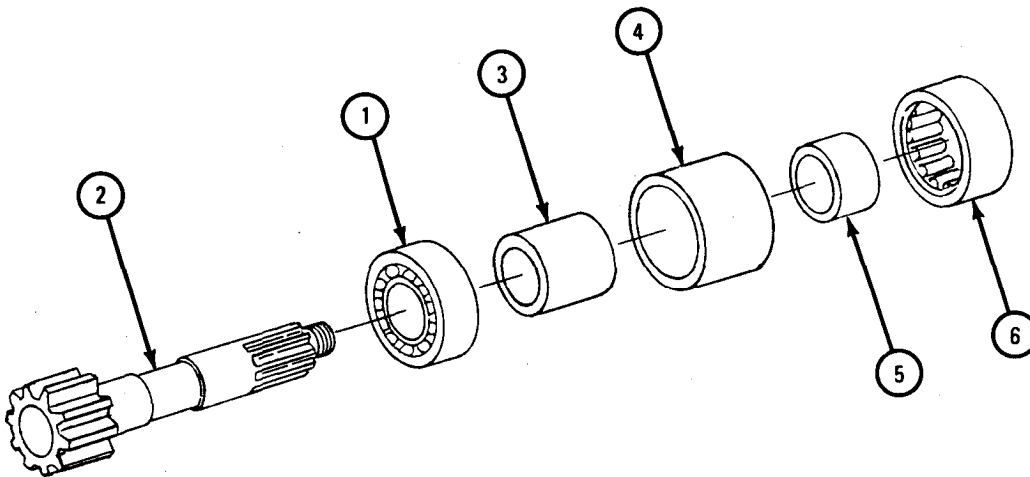

TA 088926

FRAME 10

1. Put shaft assembly (1) through opening in housing (2) until bearing (3) is seated against inside shoulder of housing.
2. If oil seal (4) was taken out, press new seal into bearing cap (5). Be sure seal lip faces toward housing side of cap.
3. Put shims (6) on bearing cap (5) as noted.
4. Put bearing cap (5) with oil seal (4) and shims (6) on housing (2). Put in four capscrews (7) and washers (8).
5. Put sleeve (9) on shaft assembly (1) through oil seal (4) until it touches bearing (10).

GO TO FRAME 11

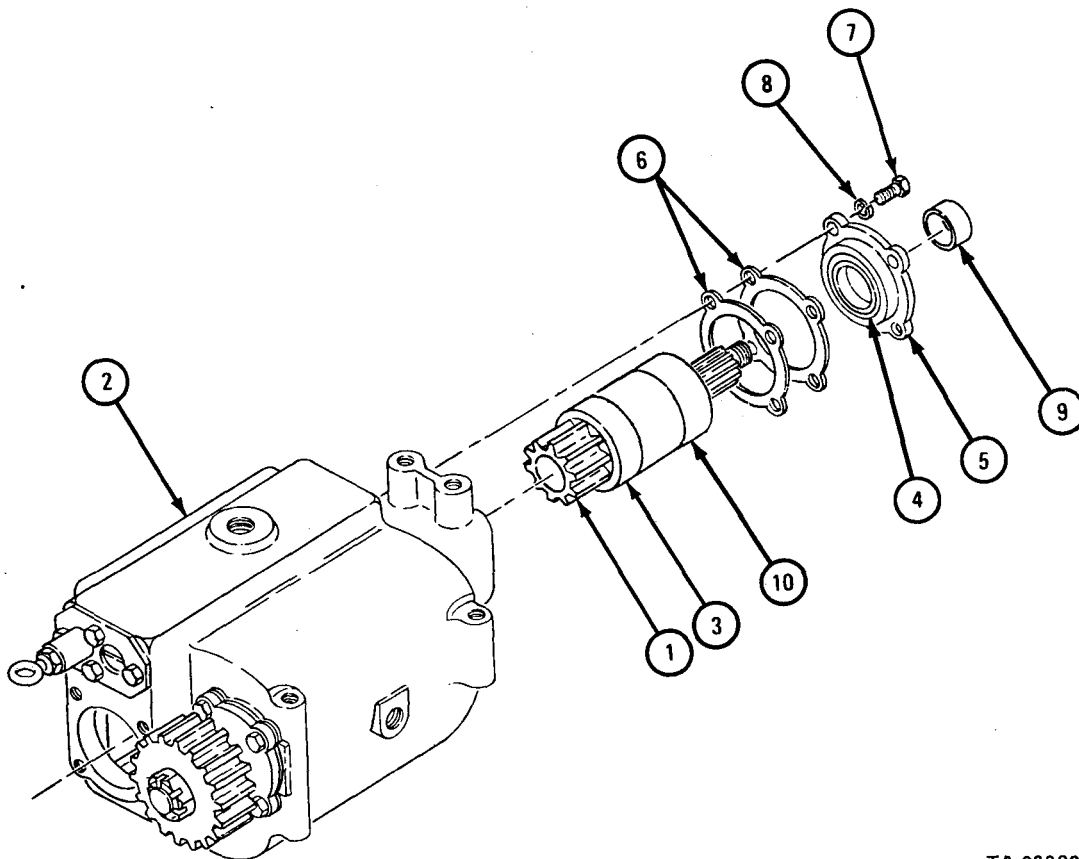

TA 088927

FRAME 11

1. Slide flange (1) over splined end of shaft (2) until it touches sleeve in housing (3).
2. Put on washer (4) and nut (5).

GO TO FRAME 12

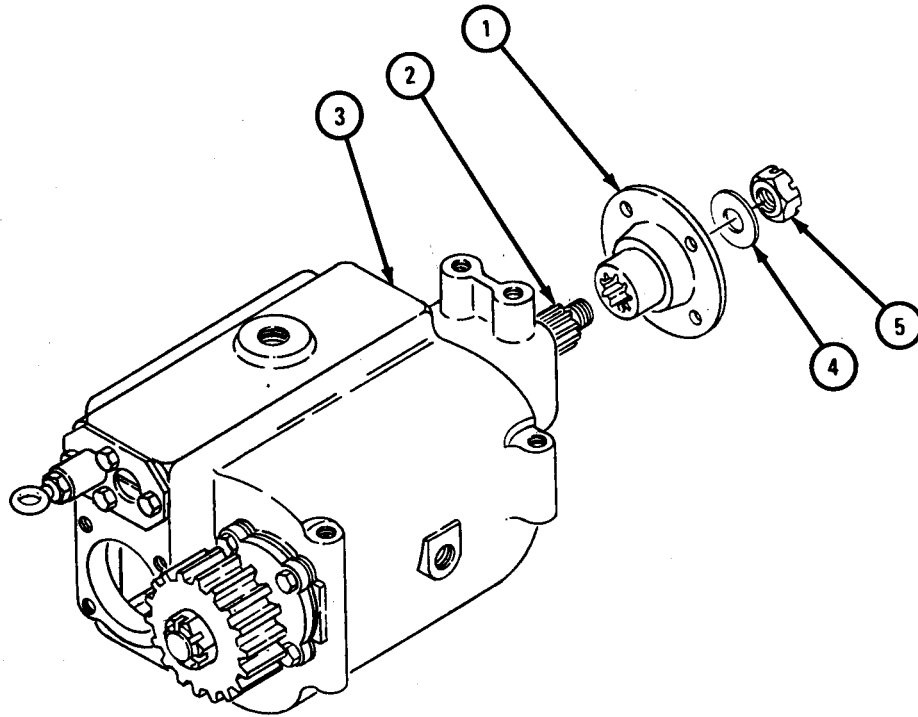

TA 088928

FRAME 12

1. Put outer race and roller portion of bearing (1) in end of gear (2).
2. Move shifter fork (3) to catch detent in third slot from front of shaft (4).
3. While holding gear (5) in shifter fork (3) with one hand, put shaft assembly (6) through front of housing (7).
4. Mesh splines of gear (5) with splines of shaft assembly (6). Push shaft assembly into housing (7) until bearing inner race (8) is seated with bearing outer race (1) in shaft (2).

GO TO FRAME 13

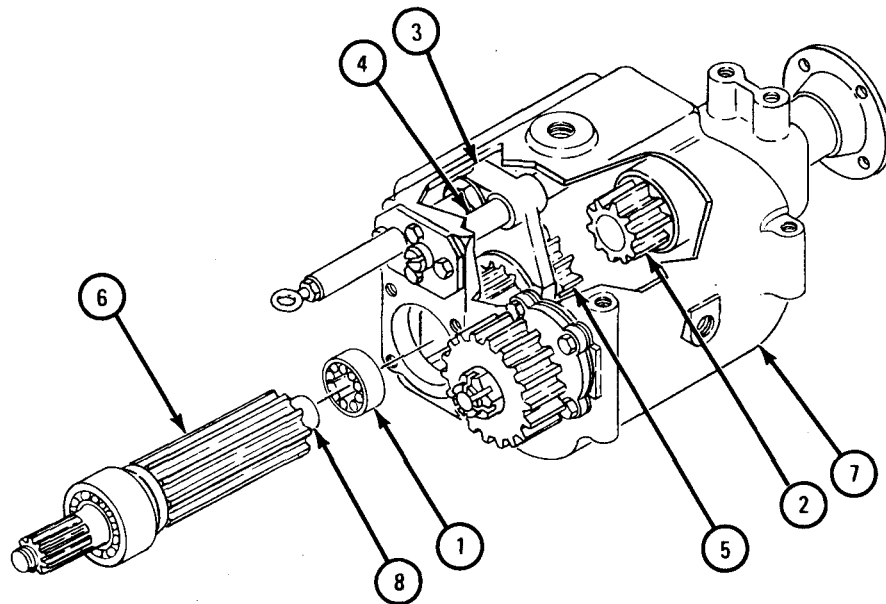

TA 088929

FRAME 13

1. If oil seal (1) was taken out of bearing cap (2), press in new seal. Make sure that lip on seal faces inside bearing cap (2) and that seal casing is flush with outer end of cap.
2. Put shims (3) on bearing cap (2) as noted.
3. Put bearing cap (2) with oil seal (1) and shims (3) on housing (4). Put in four capscrews and washers (5).
4. Put bearing sleeve (6) on shaft (7) and seat it against bearing in housing (4).
5. Put flange (8) on shaft (7). Put on nut (9) and washer (10).

GO TO FRAME 14

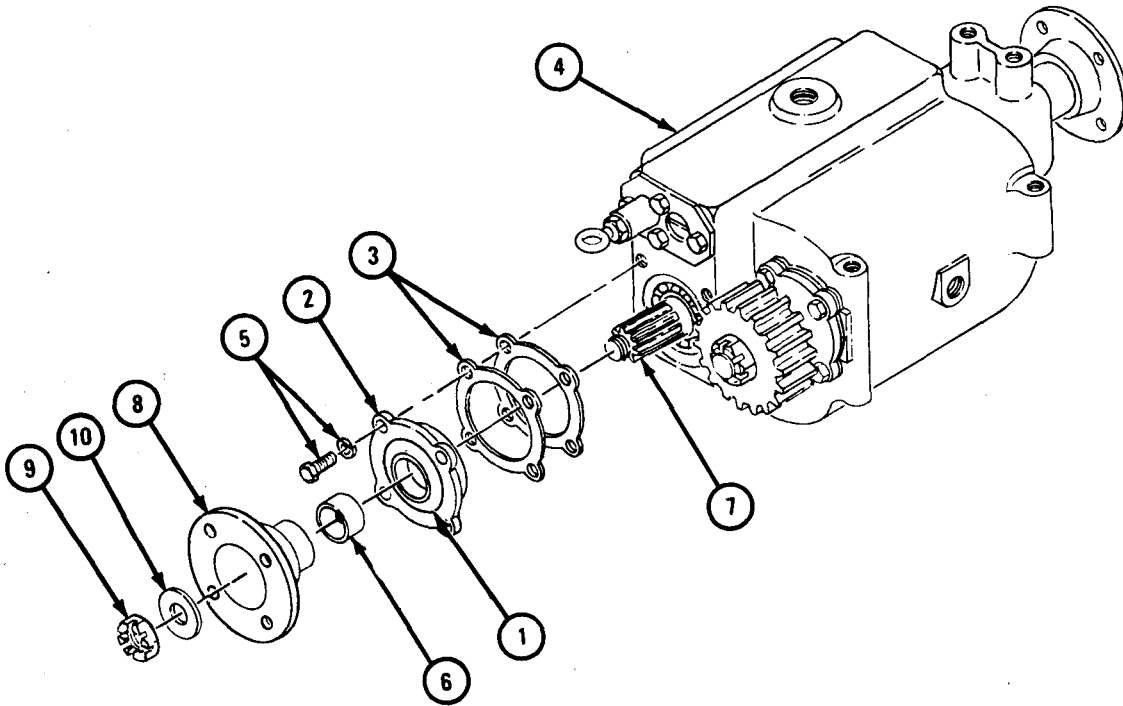

TA 088930

FRAME 14

1. Check that shafts (1 and 2) have 0.005 inch end play. If needed, take off bearing caps (3 and 4) and add or take off shims (5 and 6) until end play is 0.005 inch.
2. Put cotter pin (7) through nut (8) and shaft (1).
3. Put cotter pin (9) through nut (10) and shaft (2).

GO TO FRAME 15

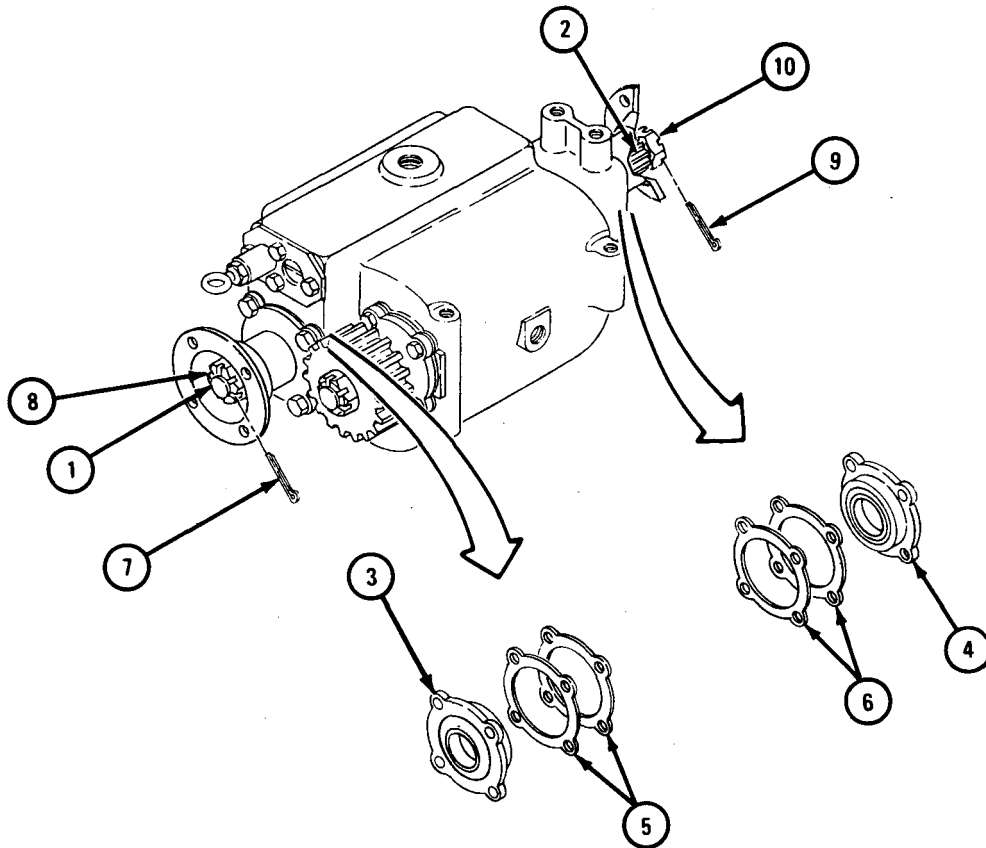

TA 088931

FRAME 15

1. Move shifter rod (1) until detent (2) in shifter fork (3) goes into neutral position slot (4) in shifter shaft (5).
2. Turn input shaft (6). Rear output shaft (7) should not turn.
3. Turn sliding gear (8). Sliding gear should turn without meshing with any other gear.
4. If sliding gear (8) meshes with reverse idler gear (9), move shifter shaft (5) with screwdriver until sliding gear is free of reverse idler gear.

GO TO FRAME 16

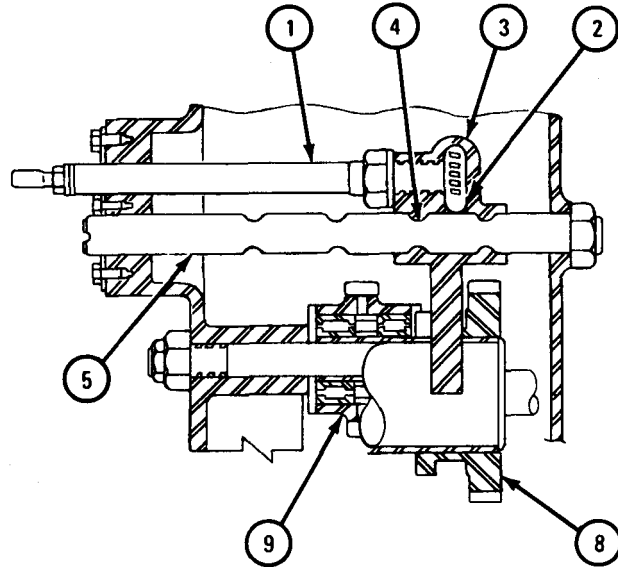
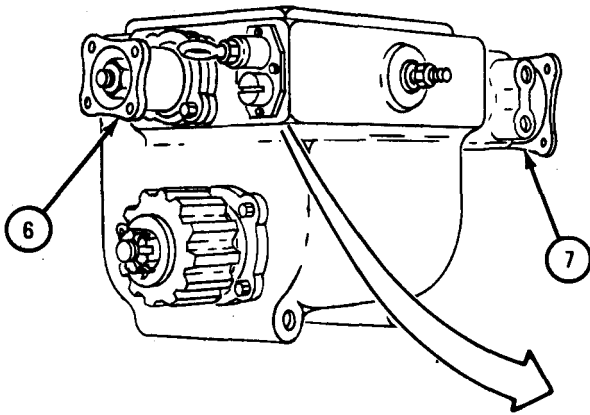

TA 088932

FRAME 16

1. Move shifter rod (1) until detent (2) in shifter fork (3) goes into rear winch reverse position (4) in shifter shaft (5). Sliding gear (6) should mesh fully with reverse idler gear (7) when input shaft (8) is turned.
2. If sliding gear (6) does not mesh fully with reverse idler gear (7), move shifter shaft (5) until gears are meshed fully.
3. Check that sliding gear (6) does not mesh with other gears in neutral position. If gear does not mesh, go back to frame 15.

GO TO FRAME 17

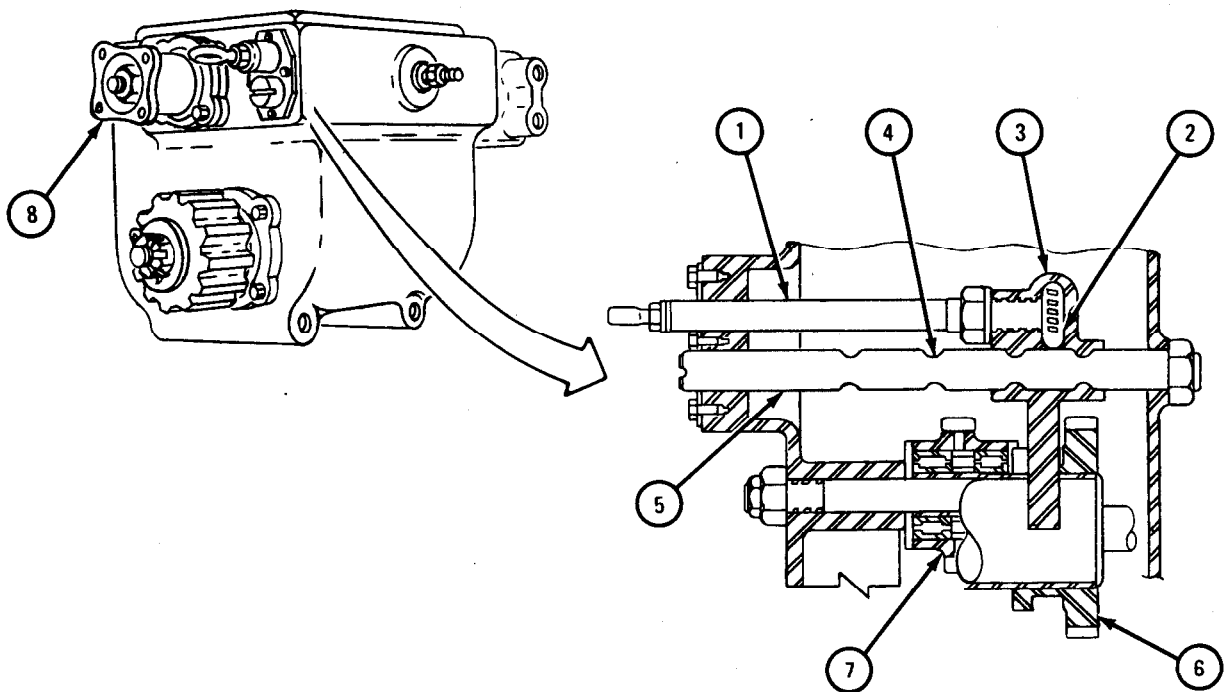

TA 088933

FRAME 17

1. Move shifter rod (1) until detent (2) in shifter fork (3) goes into rear winch forward position (4) in shifter shaft (5). Sliding gear (6) should mesh fully with forward speed gear (7) when input shaft (8) is turned.
2. If sliding gear (6) is not meshed fully with forward speed gear (7), move shifter shaft (5) with screwdriver until it is.
3. Check that sliding gear (6) does not mesh with any other gears in neutral position. Refer to frame 15.
4. Check that sliding gear (6) meshes fully with reverse idler gear in the rear winch reverse position. If gear does not mesh fully, go back to frame 16.

GO TO FRAME 18

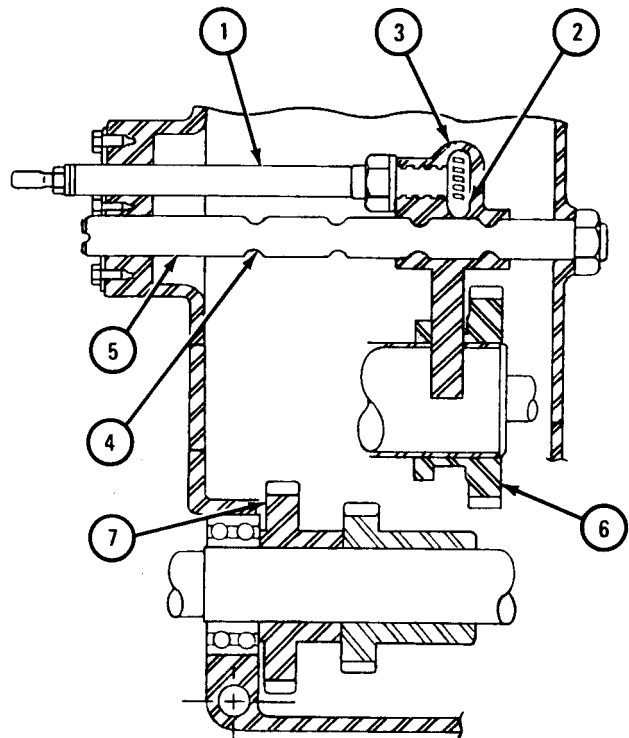
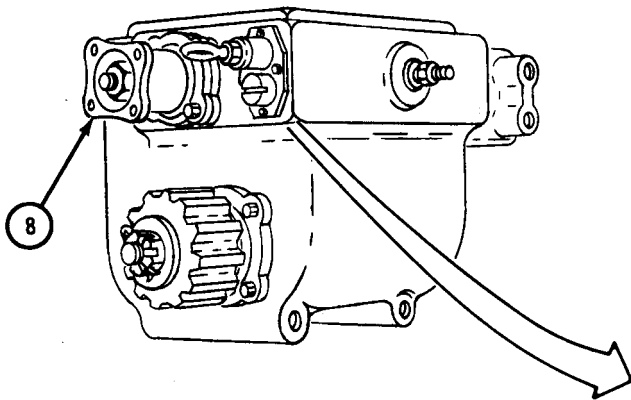

TA 088934

FRAME 18

1. Move shifter rod (1) until detent (2) in shifter fork (3) goes into earth auger position (4) in shifter shaft (5). Sliding gear (6) should be meshed with splined portion of rear output shaft (7) only. Sliding gear (6) should not be touching inside of housing (8) or meshing with forward and reverse speed gears (9) or reverse idler gear (10).
2. If sliding gear (6) is touching inside wall of housing (8) or meshing with any gear, move shifter shaft (5) with screwdriver.
3. Check that sliding gear (6) does not mesh with any gears in neutral position. If gear does mesh, go back to frame 15.
4. Check that sliding gear (6) meshes fully with reverse idler gear in rear winch reverse position. If gear does not mesh, go back to frame 16.
5. Check that sliding gear (6) meshes fully with forward speed gear in rear winch forward position. If gear does not mesh fully, go back to frame 17.

GO TO FRAME 19

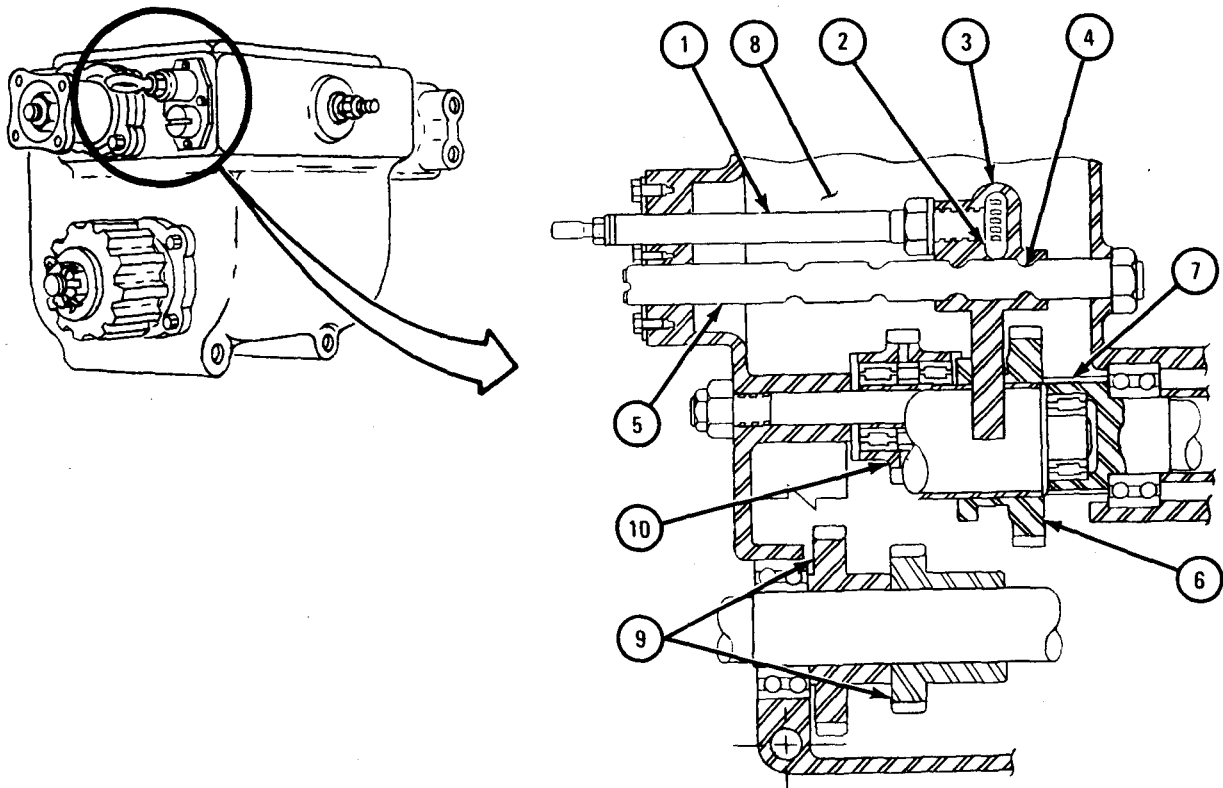

TA088935

FRAME 19

1. Put cover (1) with gasket (2) over pins (3) in housing (4).
2. Put in eight capscrews (5) and washers (6).
3. Put valve (7) with two bushings (8) into housing (4).
4. Lubricate power divider. Refer to LO 9-2320-209-12/1.

END OF TASK

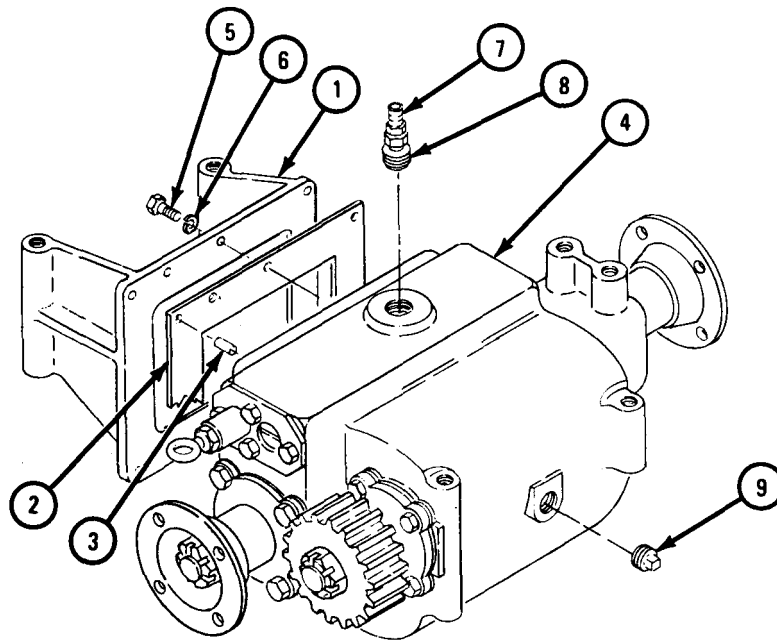

TA 088936

b. Replacement.

FRAME 1

Soldier A 1. Using hoist, raise power divider (1) into position with sprocket (2) facing toward front of truck.

NOTE

If chain (3) has been taken off, put on chain and master link after step 3.

Soldier B 2. Working from above power divider (1), lower chain (3) toward power divider (1) and hold it.

Soldier A 3. Put chain (3) on sprocket (2). Align mounting holes on power divider (1) with mounting holes on mounting b-rackets (4 and 5).

4. Put in four capscrews and washers (6). Tighten cap screws to 105 to 115 pound-feet.

GO TO FRAME 2

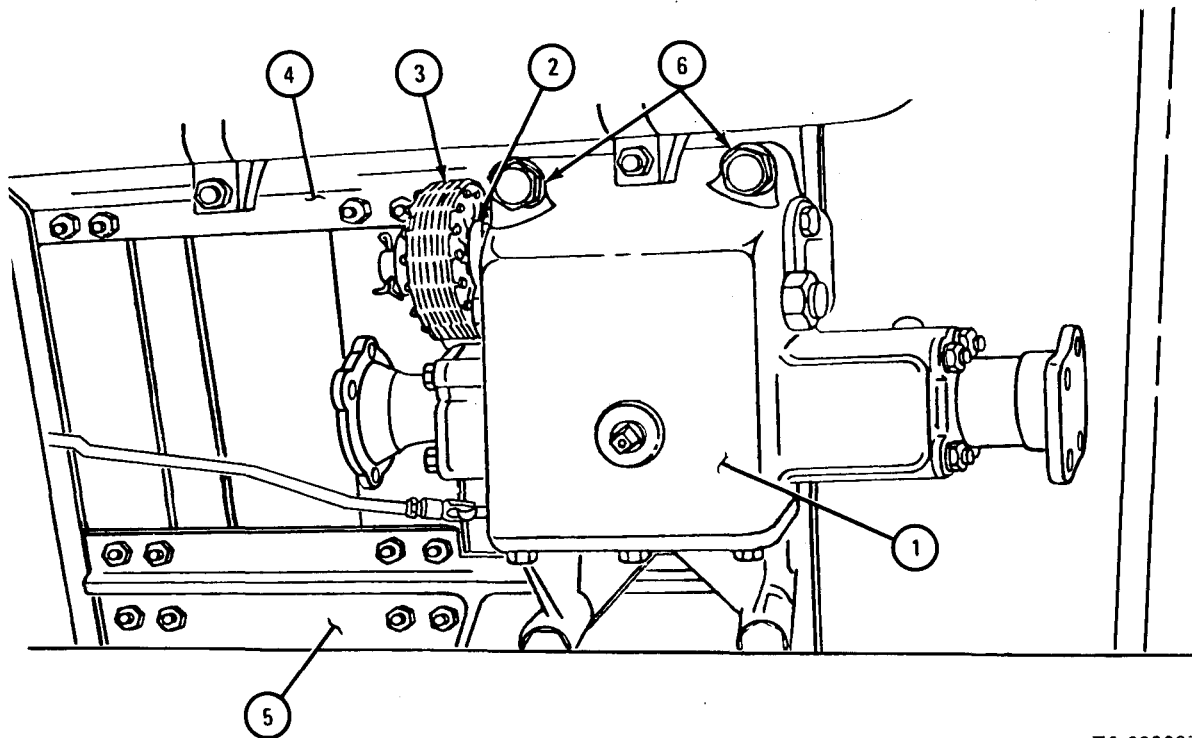

TA 088937

FRAME 2

1. Put idler pulley and bracket assembly (1) in place.
2. Put in, but do not tighten four bolts and washers (2).
3. Tighten adjusting bolt (3) until there is no slack in chain (4).
4. Tighten four mounting bolts (2).
5. Tighten locknut (5).

GO TO FRAME 3

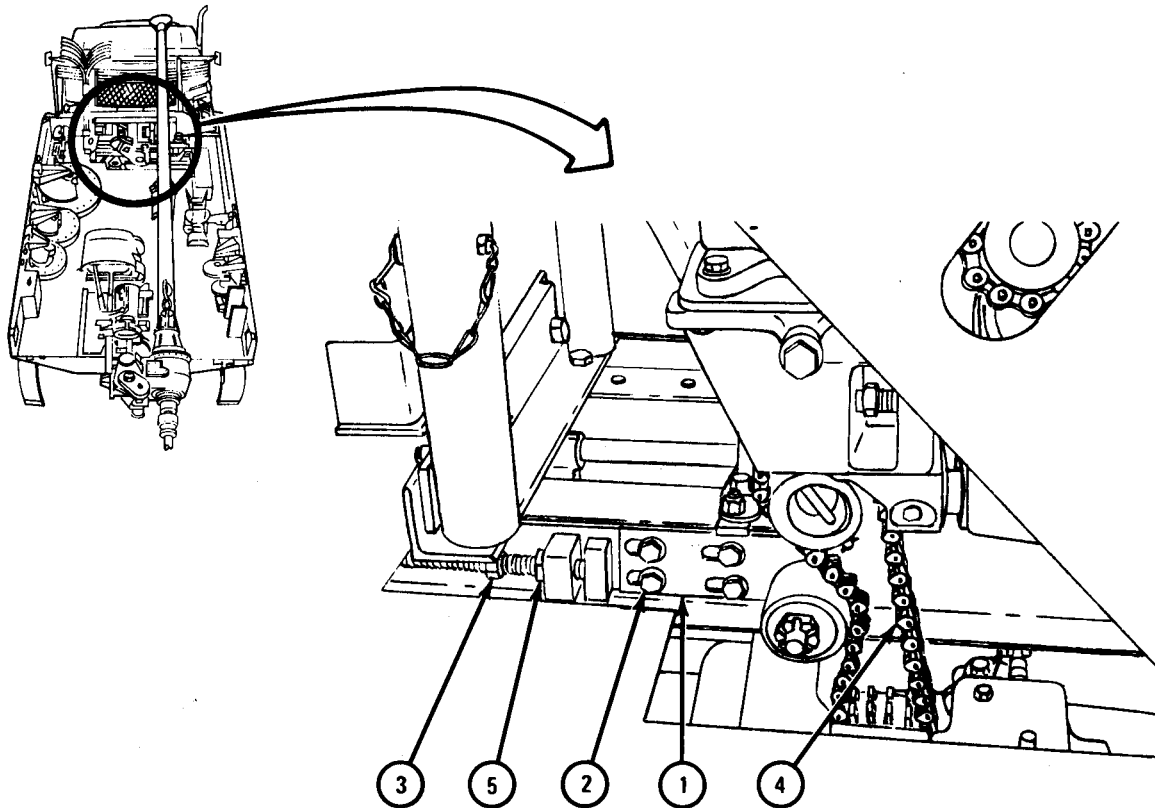

TA 088938

FRAME 3

1. Put end of control rod assembly (1) on power divider shifter shaft (2).
2. Put pin (3) through control rod assembly (1) and power divider shifter shaft (2).
3. Put in cotter pin (4).

GO TO FRAME 4

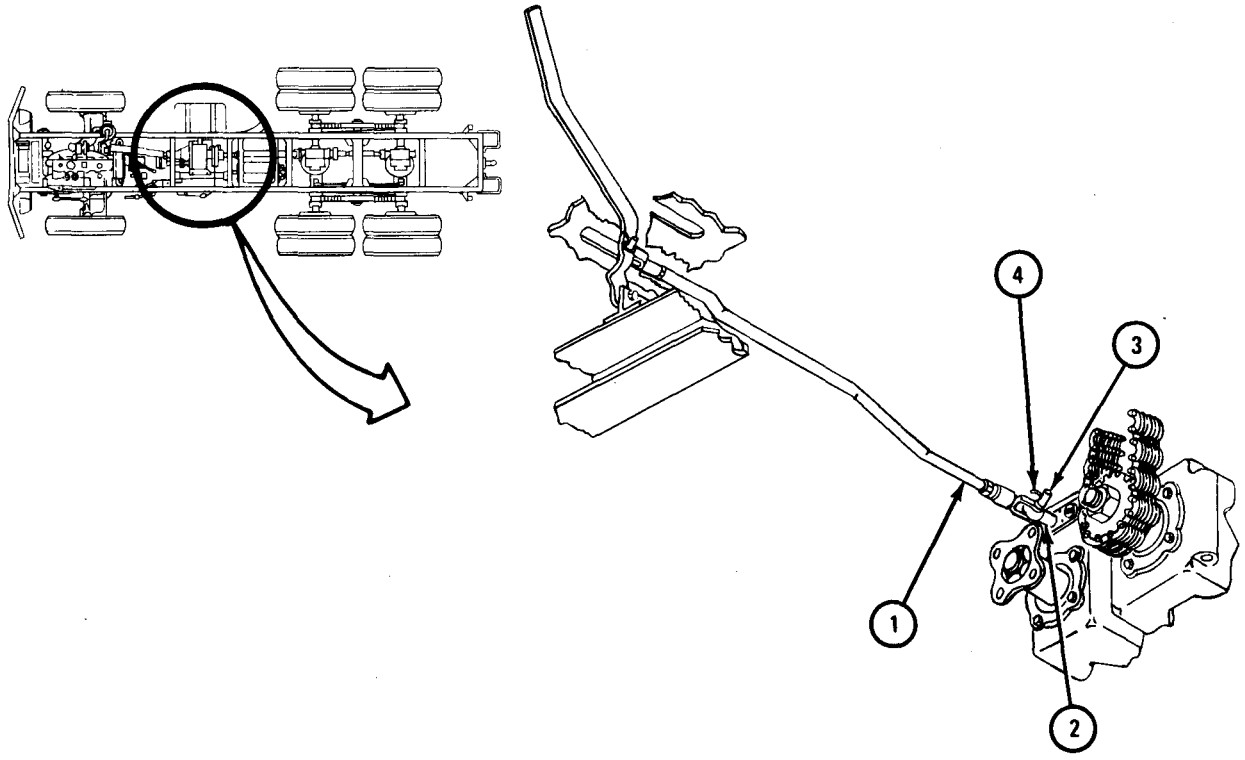

TA 088939

FRAME 4

- Soldiers 1. Working under truck, put air reservoir (1) in place as shown A and B
- Soldier B 2. Hold air reservoir (1) in place to keep it from falling.
- Soldier A 3. Put on retaining strap (2). Put in two capscrews (3) and locknuts (4).

CAUTION

Do not tighten coupling nuts (6) too much. Finger tighten coupling nut onto fitting, then tighten nut 1/8 turn.

4. Put on air line (5) between tanks. Put on two coupling nuts (6).

GO TO FRAME 5

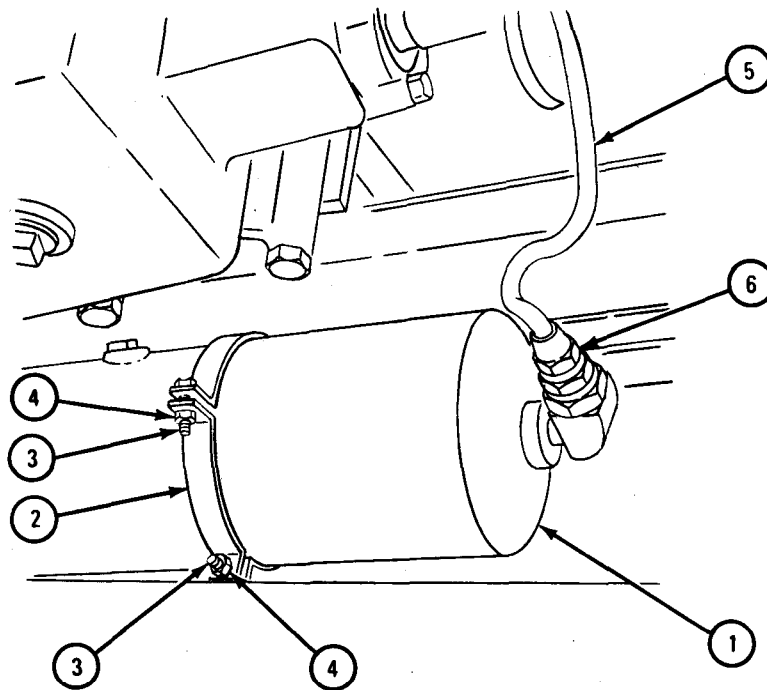

TA 088940

FRAME 5

1. Working at front of right air reservoir (1), put on retaining strap (2).
2. Put in two capscrews (3) and locknuts (4).

CAUTION

Do not tighten coupling nut (5) too much. Finger tighten coupling nut onto fitting, then tighten nut 1/8 turn.

3. Put on coupling nut (5).

NOTE

Follow-on Maintenance Action Required:

1. Do air system leak test. Refer to TM 9-2320-209-20.
2. Replace power divider propeller shaft. Refer to TM 9-2320-209-20.
3. Replace transfer-to-forward-rear axle propeller shaft. Refer to Propeller Shaft and Universal Joint Removal and Replacement, TM 9-2320-209-20.
4. Replace earth boring machine propeller shaft. Refer to TM 9-2320-209-20.

END OF TASK

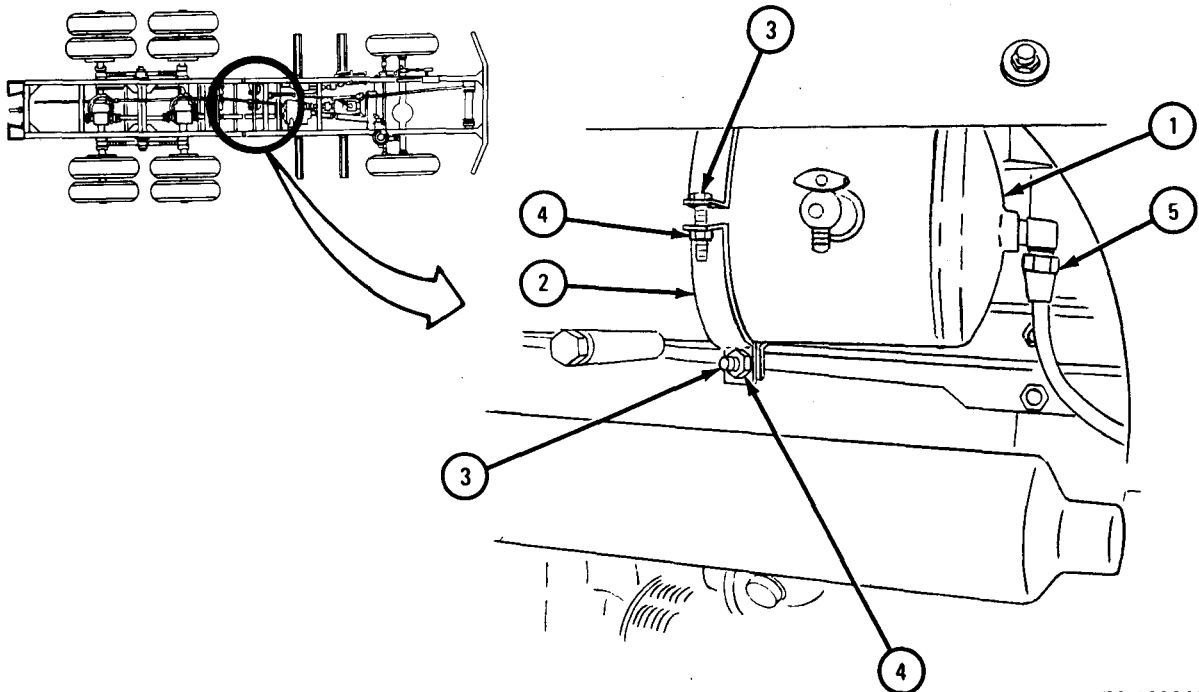

TA 088941

Section III. POWER TAKEOFF ASSEMBLY

18-13. TRANSMISSION FRONT WINCH POWER TAKEOFF REMOVAL AND REPLACEMENT.

NOTE

This task is the same for double output power takeoffs and single output power takeoffs. This task is shown for the single output power takeoff.

TOOLS: No special tools required

SUPPLIES: Transmission fluid, MIL-L-2105
Case and cover gasket

PERSONNEL: One

EQUIPMENT CONDITION: Truck parked, engine off, handbrake set.

a. Preliminary Procedures.

(1) If working on truck M342A2, remove hydraulic hoist control linkage assembly. Refer to TM 9-2320-209-20.

(2) If working on truck with front winch, remove front winch control linkage assembly. Refer to Transmission Power Takeoff Shift Linkage Removal and Replacement, TM 9-2320-209-20.

(3) Drain transmission fluid. Refer to LO 9-2320-209-12/1.

(4) If working on truck with front winch, remove front winch propeller shaft. Refer to TM 9-2320-209-20.

(5) If working on truck M342A2, remove hydraulic hoist pump propeller shaft. Refer to TM 9-2320-209-20.

CAUTION

Keep dirt out of transmission and power takeoff when doing this task. Dirt can cause damage to equipment.

b. Removal.

FRAME 1

1. Working under truck, take off six nuts (1) and washers (2).
 2. Take off power takeoff assembly (3) and gasket (4). Throw away gasket.
- END OF TASK

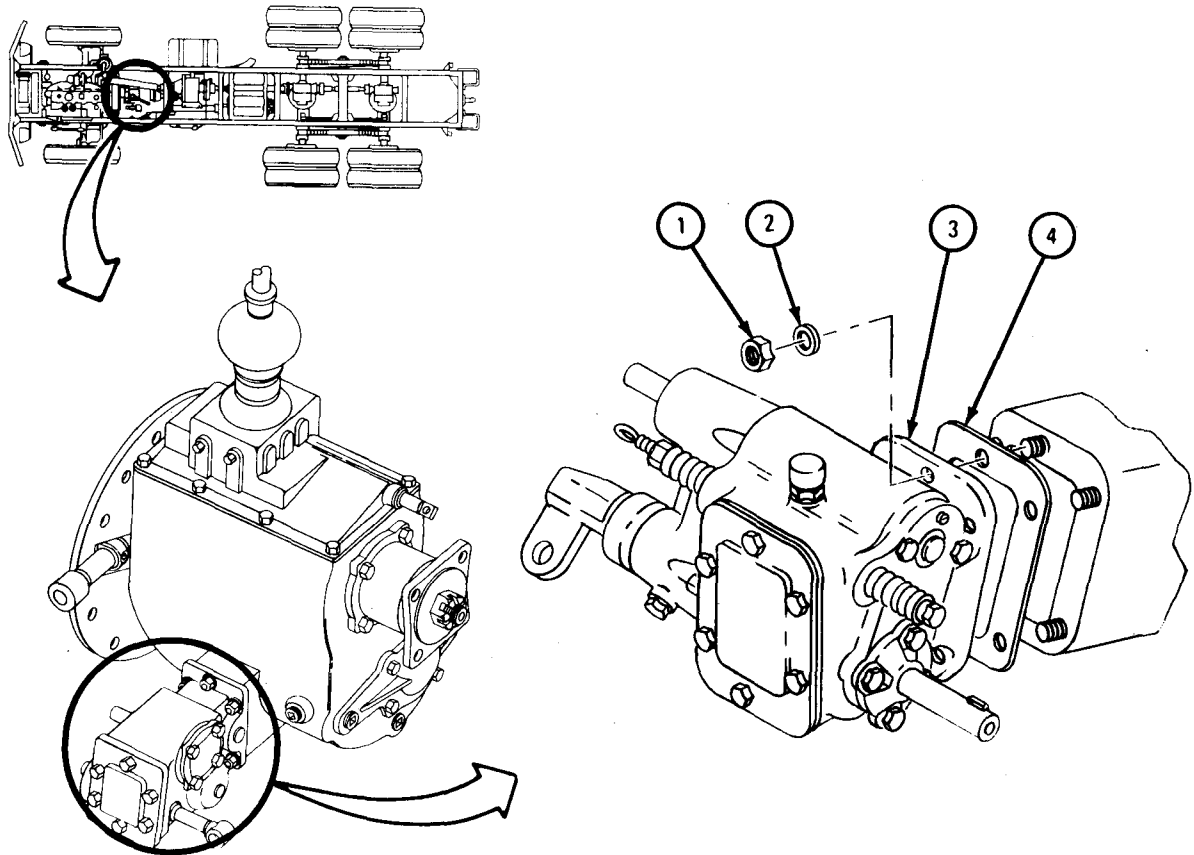

TA 084123

c. Replacement.

FRAME 1

1. Working under truck, put on gasket (1). Lift power takeoff (2) on transmission (3).
2. Put on six nuts (4) and washers (5). Tighten nuts to 30 to 40 pound-feet.

NOTE

Follow-on Maintenance Action Required:

1. If working on truck M342A2, replace hydraulic hoist pump propeller shaft and yoke. Refer to TM 9-2320-209-20.
2. If working on truck with front winch, replace front winch propeller shaft and yoke. Refer to Transmission Power Takeoff Shaft Linkage Removal and Replacement, TM 9-2320-209-20.
3. Fill transmission. Refer to LO 9-2320-209-12/1.
4. If working on truck with front winch, replace front winch propeller shaft. Refer to TM 9-2320-209-20.
5. If working on truck M342A2, replace hydraulic hoist pump propeller shaft. Refer to TM 9-2320-209-20.

END OF TASK

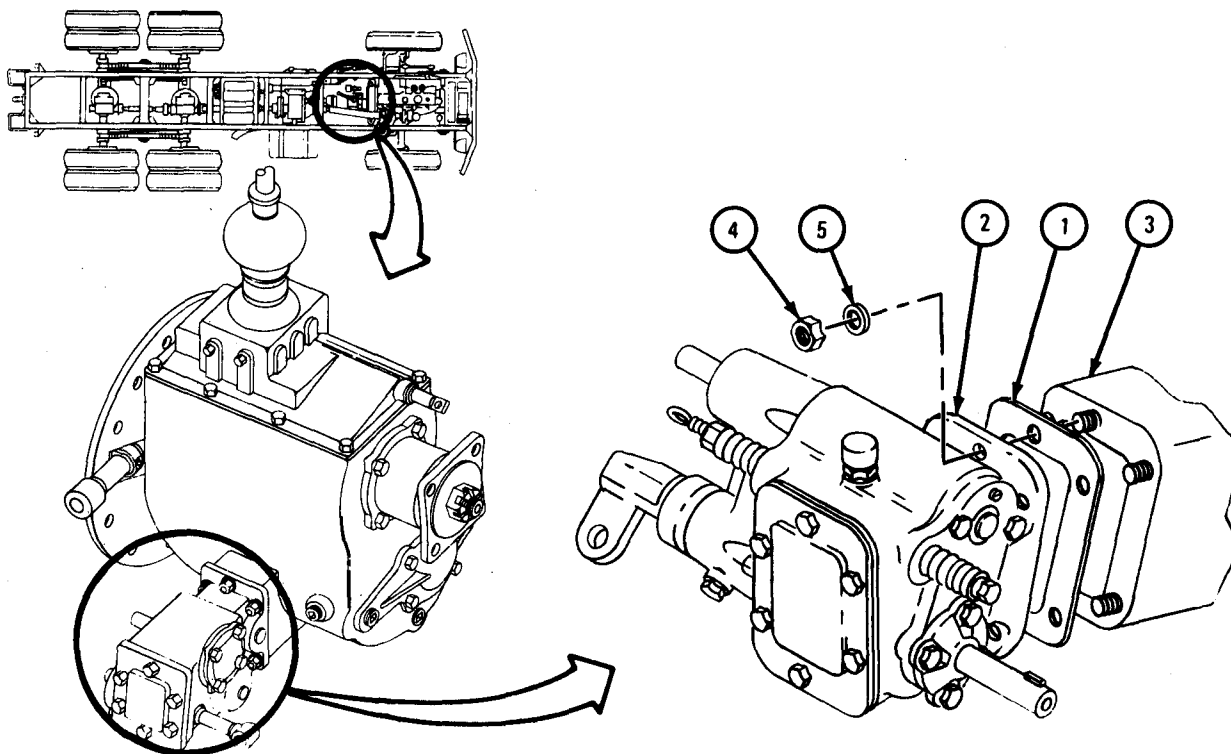

TA 084124

18-14. TRANSMISSION FRONT WINCH POWER TAKEOFF REPAIR. Refer to TM 9-2520-246-34-1 for procedure to repair transmission front winch power takeoff.

18-15. TRANSMISSION POWER TAKEOFF CONTROLS AND LINKAGE REPAIR. Repair of transmission power takeoff controls and linkage is limited to replacement of damaged parts. Refer to TM 9-2320-209-20.

18-16. TRANSMISSION TRANSFER POWER TAKEOFF REMOVAL, REPAIR AND REPLACEMENT.

TOOLS: No special tools required

SUPPLIES: None

PERSONNEL: One

EQUIPMENT CONDITION: Truck parked, engine off, handbrake set, rear wheels chocked.

a. Preliminary Procedure. Remove transmission transfer.

(1) For air actuated transmission transfer, refer to para 9-3.

(2) For double sprag transmission transfer, refer to para 9-5.

b. Removal.

FRAME 1

1. Take off tube nut (1) and tube nut (2).
 2. Take out capscrew (3).
 3. Take oil line (4) with clamp (5) off elbow fitting (6) and fitting (7).
- GO TO FRAME 2

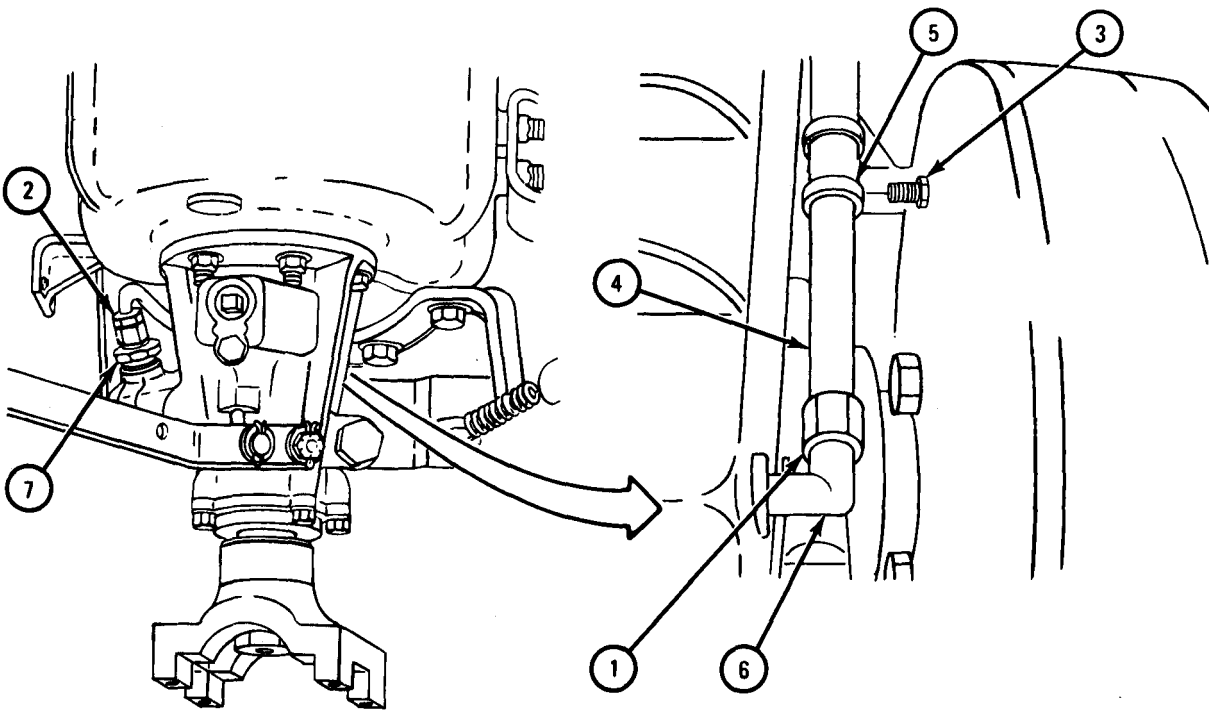

TA 085305

FRAME 2

1. Take out four capscrews and lockwashers (1).
2. Take off two nuts and lockwashers (2).
3. Take off power takeoff (3) and gasket (4). Throw away gasket.

END OF TASK

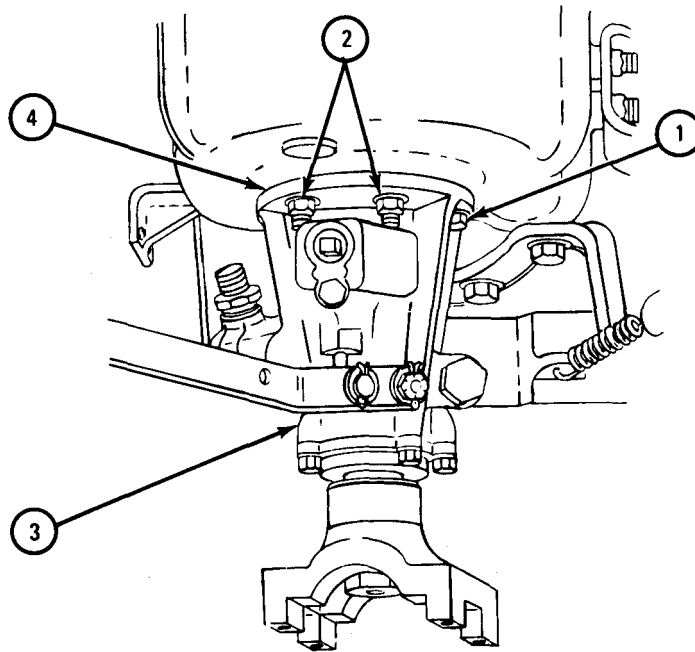

TA 101891

c. Repair. Refer to TM 9-2520-246-34 for procedures to repair the transmission transfer power takeoff.

d. Replacement.

FRAME 1

1. Put on gasket (1) and power takeoff (2).
2. Put on two nuts and washers (3).
3. Put in four capscrews and lockwashers (4).

GO TO FRAME 2

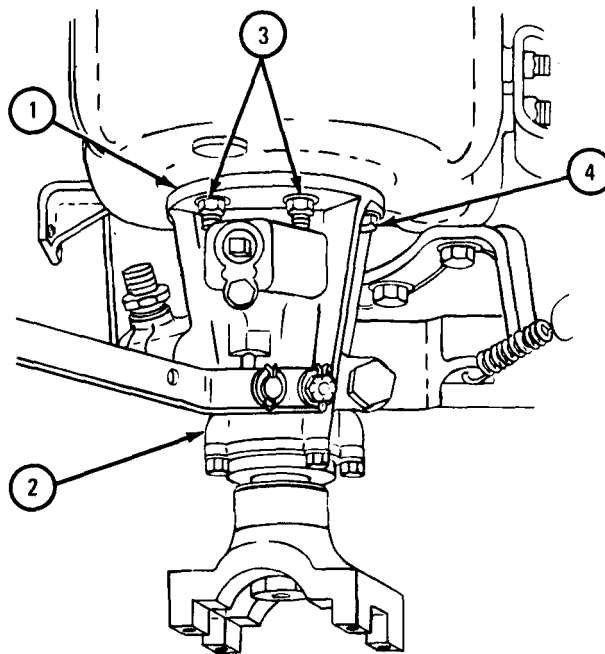

TA 101892

FRAME 2

1. Put oil line (1) with clamp (2) in place on elbow fitting (3) and fitting (4).
2. Put capscrew (5) through clamp (2) and into transmission transfer case (6).
3. Put on tube nut (7) and tube nut (8).

NOTE

Follow-on Maintenance Action Required:

1. Replace transmission transfer.
 - a. For air actuated transmission transfer, refer to para 9-3.
 - b. For double sprag transmission transfer, refer to para 9-5.
2. Fill transmission transfer. Refer to LO 9-2320-209-12/1.

END OF TASK

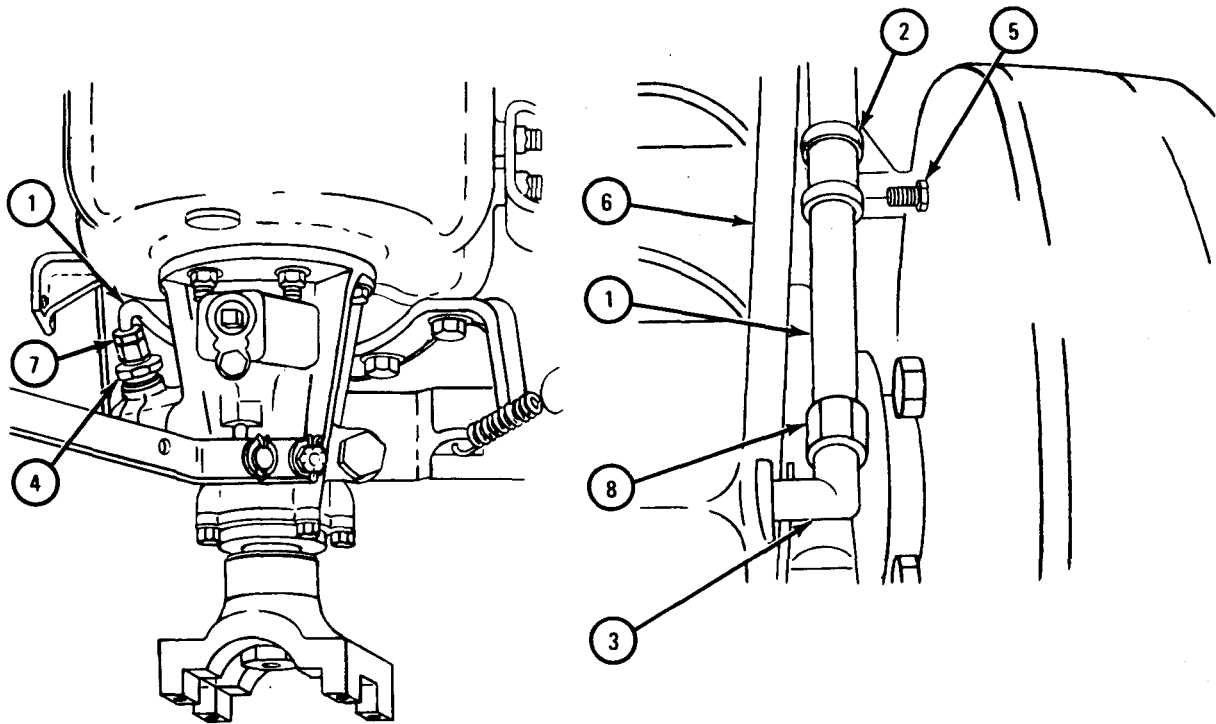

TA 105217

18-17. TRANSMISSION TRANSFER POWER TAKEOFF CONTROLS AND LINKAGE REPAIR. Repair of transfer power takeoff controls and linkage is limited to replacement of damaged parts. Refer to TM 9-2320-209-20.

CHAPTER 19

BUMPER AND GUARDS GROUP MAINTENANCE

Section I. SCOPE

19-1. EQUIPMENT ITEMS COVERED. This chapter gives equipment maintenance procedures for the bumper, brackets, guards, and protective devices for which there are authorized corrective maintenance tasks at the direct and general support maintenance levels.

19-2. EQUIPMENT ITEMS NOT COVERED. All equipment items for which corrective maintenance is authorized at the direct and general support maintenance levels are covered in this chapter.

Section II. BUMPER, BRACKETS, GUARDS, AND PROTECTIVE DEVICES

19-3. FRONT BUMPER REINFORCING GUSSETS REMOVAL, REPAIR, AND REPLACEMENT (ALL TRUCKS WITHOUT FRONT WINCH).

TOOLS: No special tools required

SUPPLIES: Solvent, dry cleaning, type II (SD-2), Fed. Spec P-D-680
Rags

PERSONNEL: Two

EQUIPMENT CONDITION: Truck parked, engine off, handbrake set.

a. Preliminary Procedures.

(1) Remove brush guard. Refer to para 19-5.

(2) Remove two lifting shackles and lifting shackle brackets. Refer to TM 9-2320-209-20.

b. Removal.

FRAME 1

1. Working under bumper (1) takeout three screws (2) and self-locking nuts (3) from both lower bumper gussets (4).

Soldiers A and B 2. Take off bumper (1).

END OF TASK

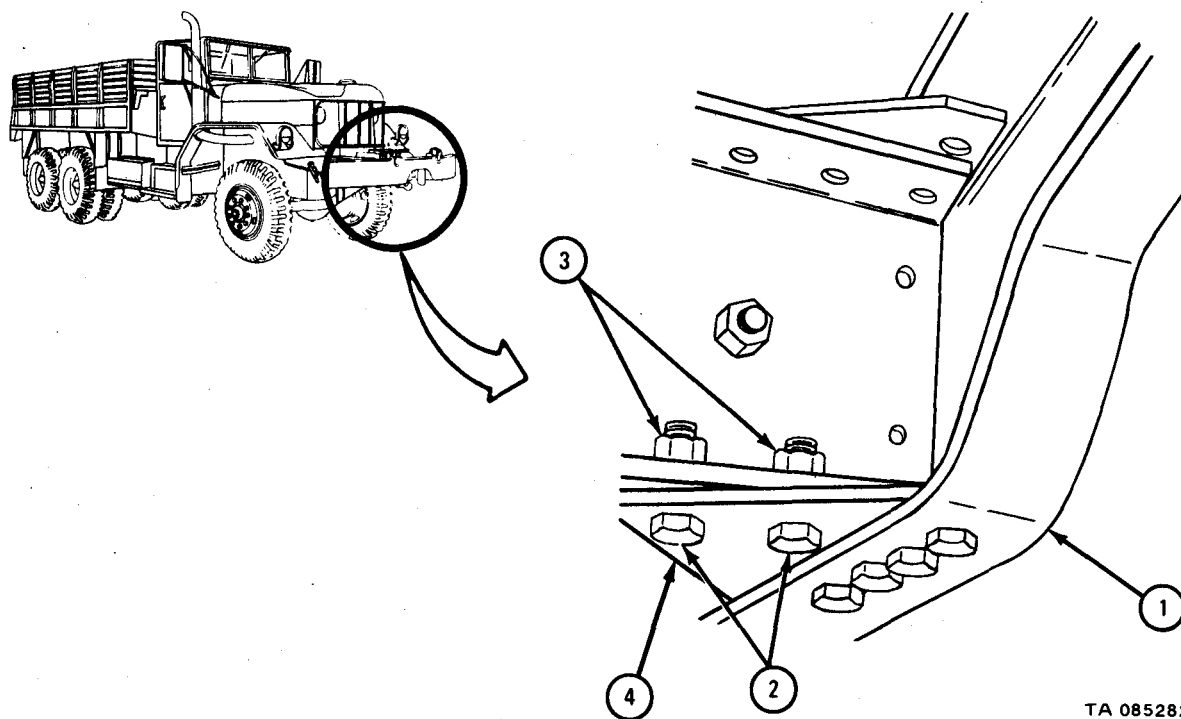

TA 085282

c. Disassembly.

FRAME 1

1. Take off three screws with self-locking nuts (1) holding upper gasket (2) to bumper bar (3).
2. Take off five screws with self-locking nuts (4) holding lower gasket (5) to bumper bar (3).
3. Take off upper and lower gaskets (2 and 5).
4. Do steps 1 through 3 again on other side of bumper bar (3).

END OF TASK

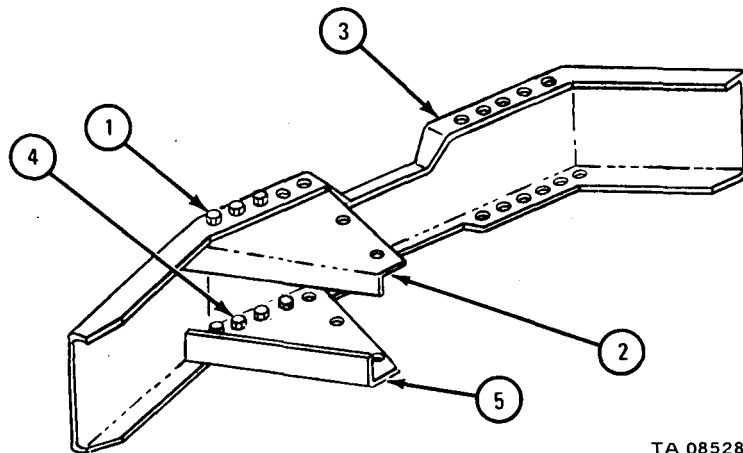

TA 085283

WARNING

Dry cleaning solvent is flammable. Do not use near an open flame. Keep a fire extinguisher nearby when solvent is used. Use only in well-ventilated places. Failure to do this may result in injury to personnel and damage to equipment.

- d. Cleaning. Clean all parts well with solvent. Let parts dry.
- e. Inspection and Repair.

FRAME 1

1. Check that bumper (1) and gussets (2) are not cracked, broken or bent. Straighten or weld damaged parts. Refer to FM 43-2 or TM 9-237.

END OF TASK

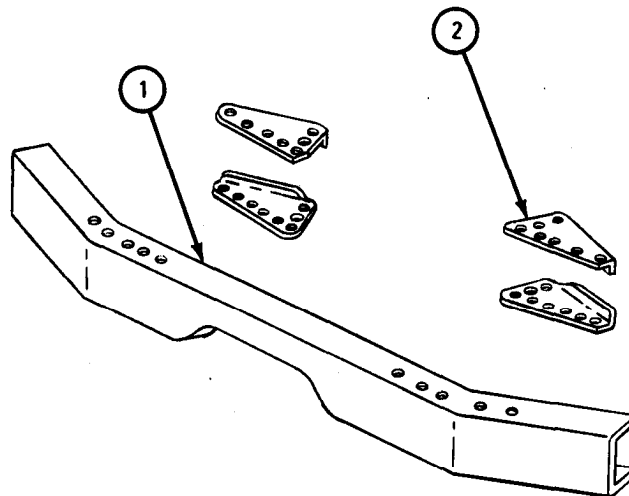

TA 085284

f. Assembly.

FRAME 1

1. Hold upper gusset (1) in place.
2. Put in three screws and self-locking nuts (2).
3. Hold lower gusset (3) in place.
4. Put in five screws and self-looking nuts (4).
5. Do steps 1 through 4 again on other side of bumper bar (5).

END OF TASK

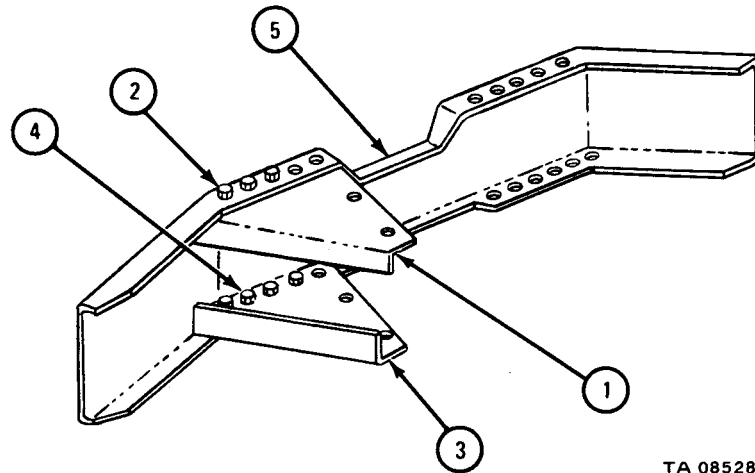

TA 085285

g. Replacement.

FRAME 1

Soldiers 1. Lift bumper (1) into place.
A and B

Soldier A 2. Put in three screws (2) and self-locking nuts (3) joining two lower bumper gussets (4) to frame.

NOTE

Follow-on Maintenance Action Required:

1. Replace two lifting shackles and lifting shackle brackets. Refer to TM 9-2320-209-20.
2. Replace brush guard. Refer to para 19-5.

END OF TASK

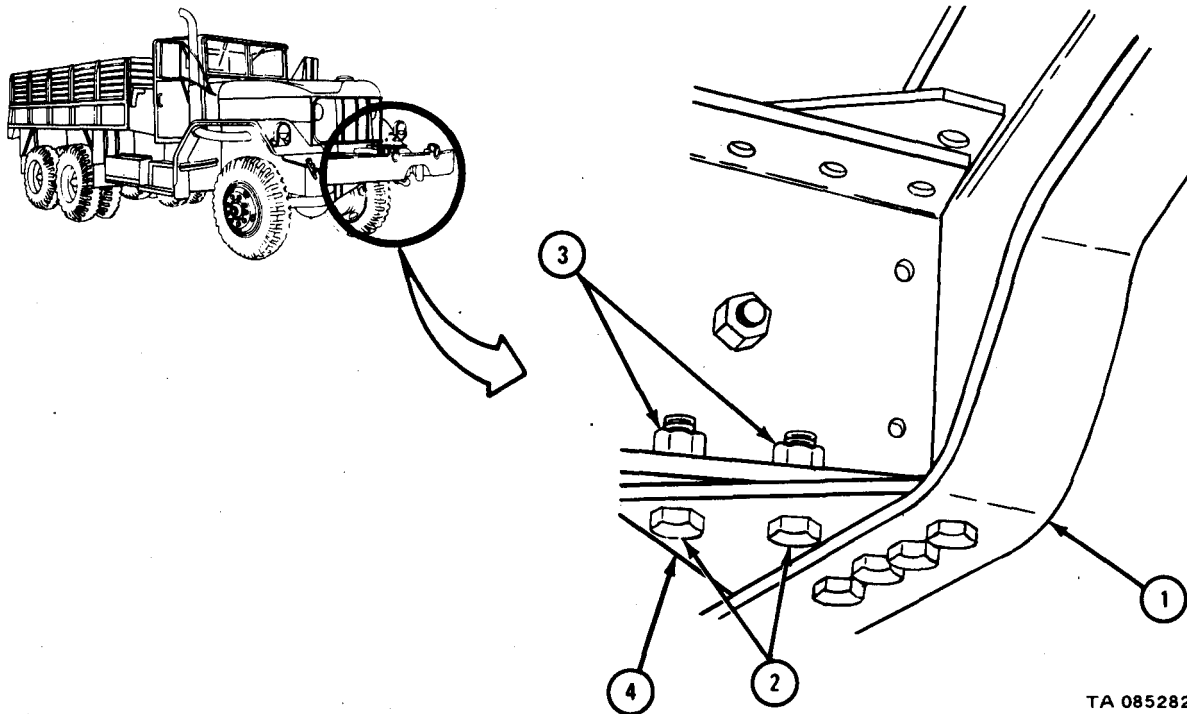

TA 085282

19-4. FRONT BUMPER AND REINFORCING GUSSETS REMOVAL, REPAIR, AND REPLACEMENT (ALL TRUCKS WITH FRONT WINCH).

TOOLS: No special tools required.

SUPPLIES: None

PERSONNEL: Two

EQUIPMENT CONDITION: Truck parked, engine off, handbrake set.

a. Preliminary Procedure. Remove two front lifting shackles. Refer to TM 9-2320-209-20.

b. Removal.

FRAME 1

1. Take off screw and self-locking nut (1) from left and right lower bumper gussets (2).

Soldiers A and B 2. Take off bumper bar (3) with gussets (2 and 4).

GO TO FRAME 2

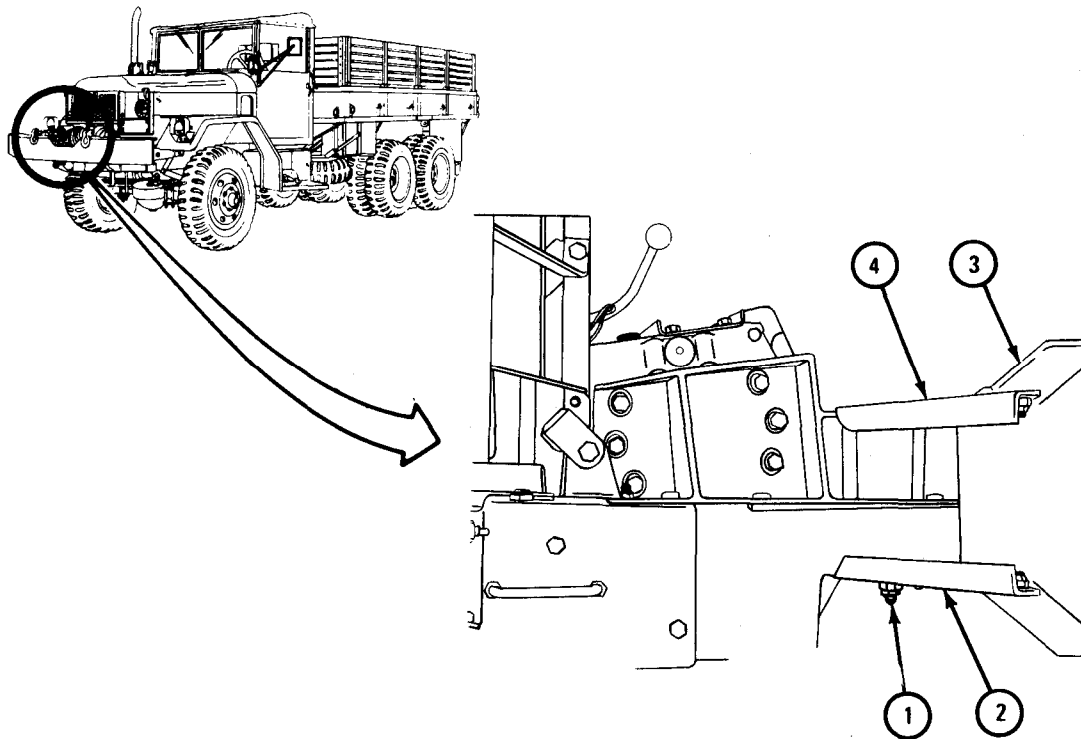

TA 085233

FRAME 2

1. Take off three screws with self-locking nuts (1) holding upper gusset (2) to bumper bar (3).
2. Take off three screws with self-locking nuts (4) holding lower gusset (5) to bumper bar (3).
3. Take off upper and lower gussets (2 and 5).
4. Do steps 1 through 3 again on other side of bumper bar (3).

END OF TASK

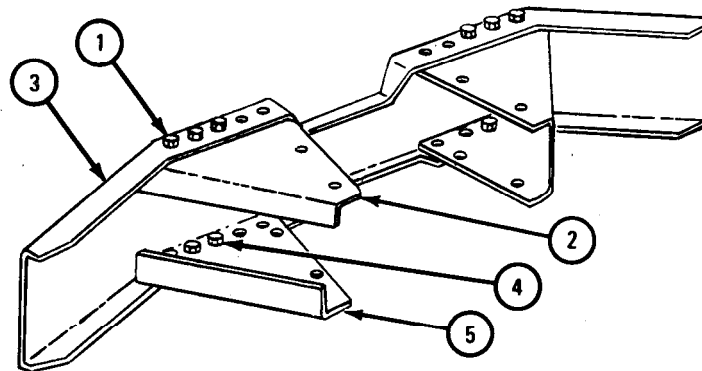

TA 085234

c. Cleaning. There are no special cleaning procedures required. Refer to cleaning procedures given in Part 1, para 1-3.

d. Inspection and Repair.

FRAME 1

1. Check that bumper (1) and gussets (2) are not cracked, broken or bent. Repair damaged parts by straightening or welding. Refer to TM 9-237.

END OF TASK

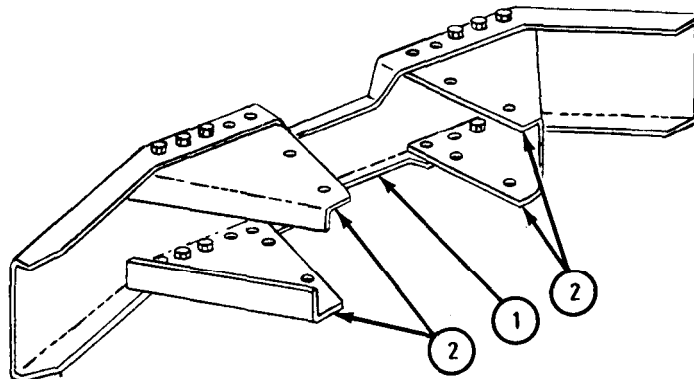

TA 085235

e. Replacement.

FRAME 1

1. Hold upper gusset (1) in place on bumper bar (2).
2. Put in three screws with self-locking nuts (3).
3. Hold lower gusset (4) in place on bumper bar (2).
4. Put in three screws with self-locking nuts (5).
5. Do steps 1 through 4 again on other side of bumper bar (2).

GO TO FRAME 2

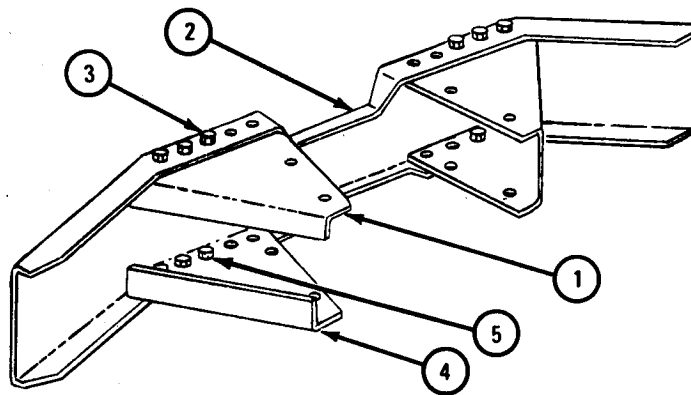

TA 085236

FRAME 2

- Soldiers A and B 1. Lift bumper bar (1) into place on truck.
- Soldier A 2. Put screw and self-locking nut (2) in left and right lower bumper gussets (3).

NOTE

Follow-on Maintenance Action Required:

Put back two front lifting shackles. Refer to TM 9-2320-209-20.

END OF TASK

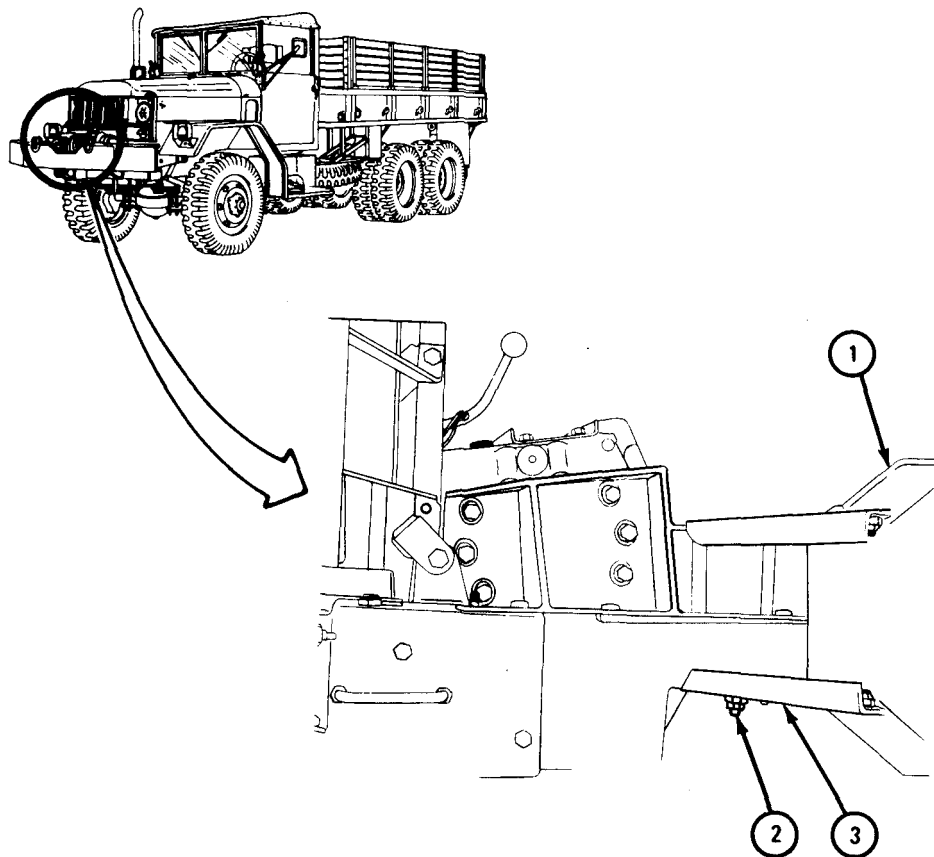

TA 085237

19-5. RADIATOR BRUSH GUARD REMOVAL, REPAIR, AND REPLACEMENT.

TOOLS: No special tools required

SUPPLIES: Solvent, dry cleaning, type II (SD-2), Fed. Spec P-D-680

PERSONNEL: One

EQUIPMENT CONDITION: Truck parked, engine off, handbrake set.

a. Preliminary Procedures.

(1) Open hood. Refer to TM 9-2320-209-10.

(2) If truck has stone guard, remove it. Refer to Radiator Stone Shield Removal and Replacement, TM 9-2320-209-20.

b. Removal.

FRAME 1

1. Loosen two screws (1) and nuts (2).
2. Do step 1 again on other side of brush guard (3).
3. Move brace (4) back out of the way.
4. Pull brush guard (3) up and off of truck.

END OF TASK

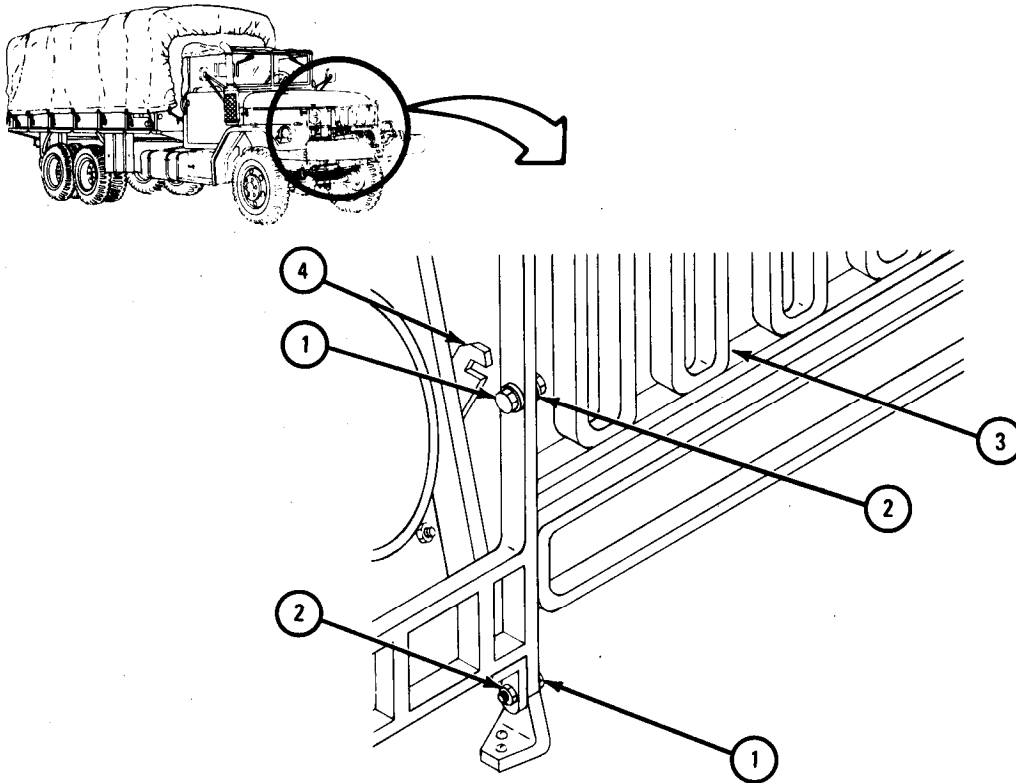

TA 085375

c. Disassembly.

FRAME 1

NOTE

Note position of two headlight guard bars (1 and 2) before taking them off.

1. Take off three screws (3), three nuts (4), and one flatwasher (5). Take off headlight guard bar (1).
2. Do step 1 again for other headlight guard bar (2).

NOTE

Trucks with front winch do not have brace (6).

3. Take off four screws (7) and four nuts (8). Take off brace (6).

END OF TASK

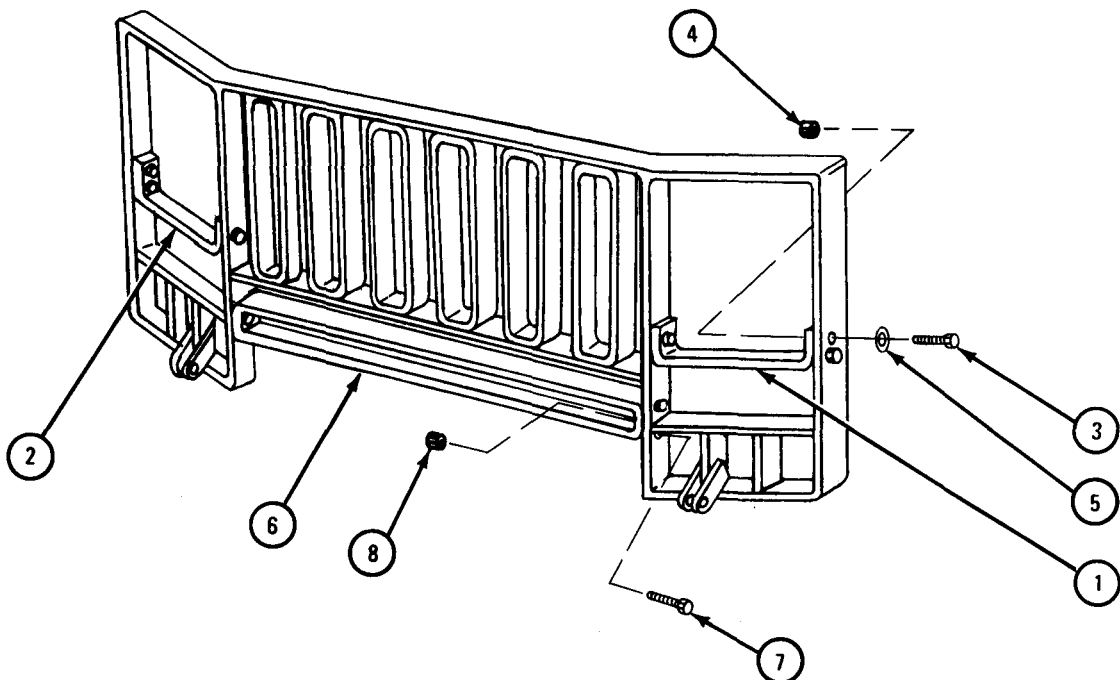

TA 085376

WARNING

Dry cleaning solvent is flammable. Do not use near an open flame. Keep a fire extinguisher nearby when solvent is used. Use only in well-ventilated places. Failure to do this may result in injury to personnel and damage to equipment.

d. Cleaning. Clean all parts in solvent. Steam, wire brush or scraper may be used to take off heavy grease.

e. Inspection and Repair.

FRAME 1

NOTE

Trucks with front winches do not have brace (1).

1. Check that brace (1), brush guard (2) and two headlight guard bars (3) are not bent, dented or cracked and have no broken welds. Repair damage by straightening or welding. Refer to TM 9-237.
2. If parts need more repair, throw them away and get new ones in their place.

END OF TASK

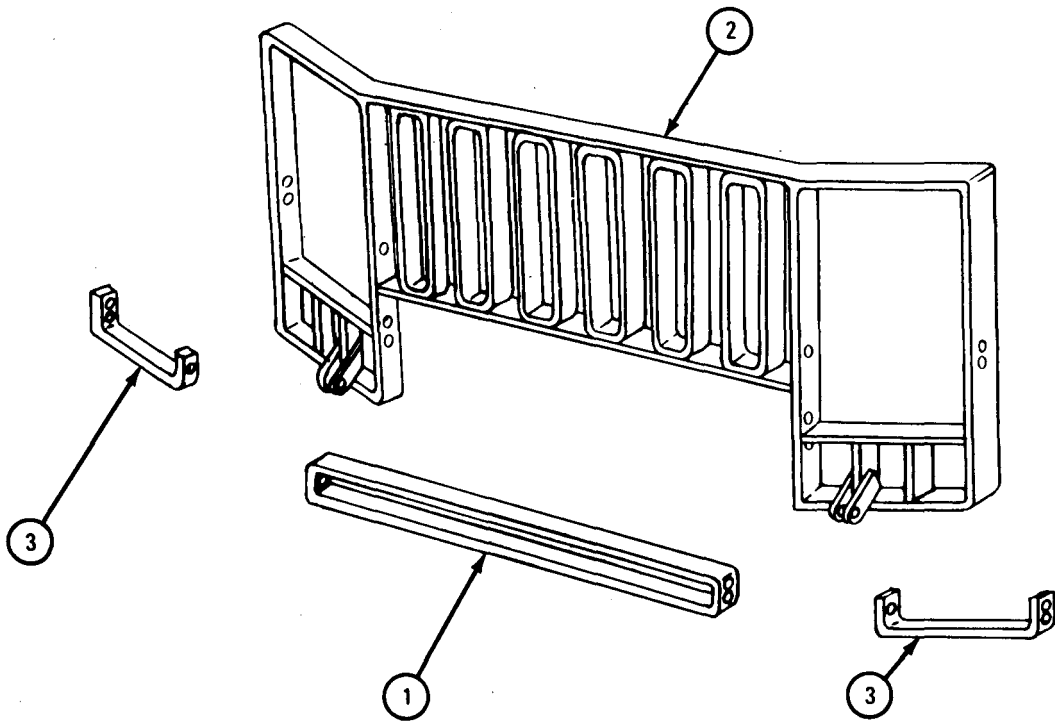

TA 085378

f. Assembly.

FRAME 1

NOTE

Trucks with front winch do not have brace (1).

- 1. Put in brace (1) and four screws (2) and nuts (3).
- 2. Put on two headlight guard bars (4) in positions noted during removal.
- 3. Put in six screws (5), two flatwashers (6), and six nuts (7).

END OF TASK

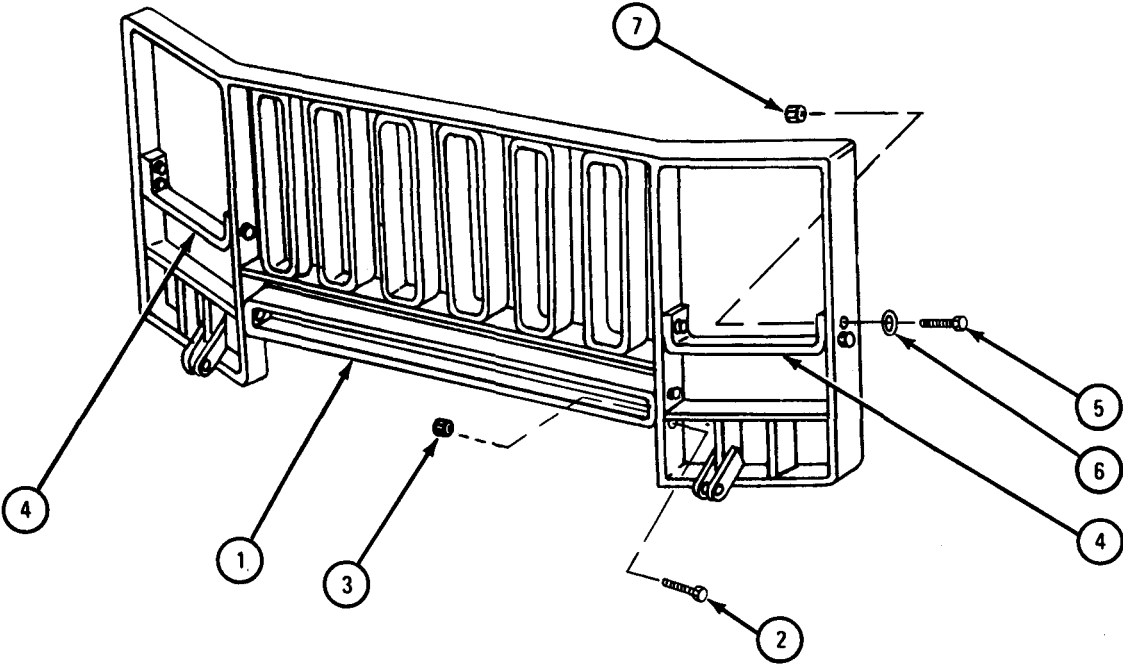

TA 085379

g. Replacement.

FRAME 1

1. Put brush guard (1) in place.
2. Put in screw (2).
3. Put nut (3) on screw (2) hand tight.
4. Do steps 2 and 3 again for other side of brush guard (1).
5. Lower brace (4) onto screw (5) with washer (6) on outside of brace.
6. Do step 5 again for other side of brush guard (1).
7. Tighten all screws (2 and 5).

NOTE

Follow-on Maintenance Action Required:

1. If truck has a stone guard, replace it. Refer to Radiator Stone Shield Removal and Replacement, TM 9-2320-209-20.
2. Close hood. Refer to TM 9-2320-209-10.

END OF TASK

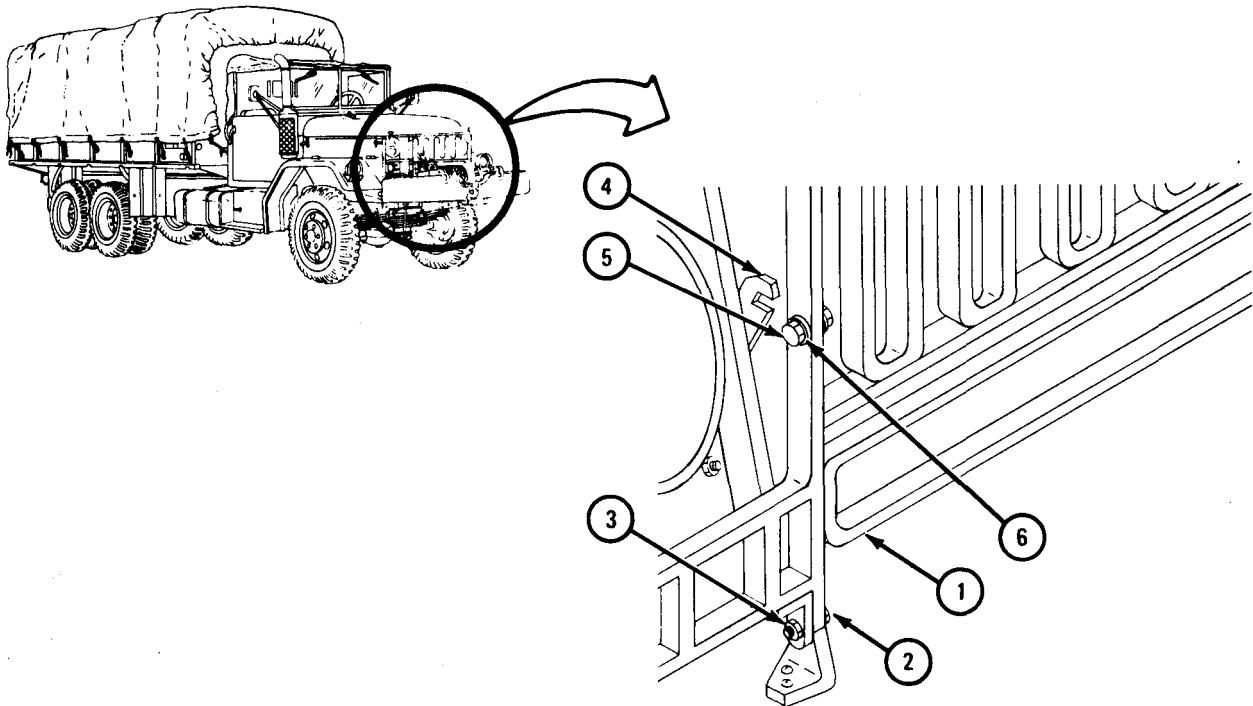

TA 085381

19-6. VEHICLE FUEL TANK SUPPORT REMOVAL AND REPLACEMENT (ALL TRUCKS EXCEPT TRUCKS M275A1 AND M275A2).

TOOLS: No special tools required

SUPPLIES: None

PERSONNEL: One

EQUIPMENT CONDITION: Truck parked, engine off, handbrake set.

WARNING

Smoking, sparks, or open flame are not allowed within 50 feet of work area during this task. Fuel may explode, causing serious injury to personnel and damage to equipment.

a. Preliminary Procedure. Remove fuel tank. Refer to TM 9-2320-209-20.

b. Removal.

FRAME 1

1. Take out screw and nut (1) from two fuel tank straps (2). Take off straps.
2. Take out screw and nut (3) from two retaining bands (4). Take off retaining bands.

GO TO FRAME 2

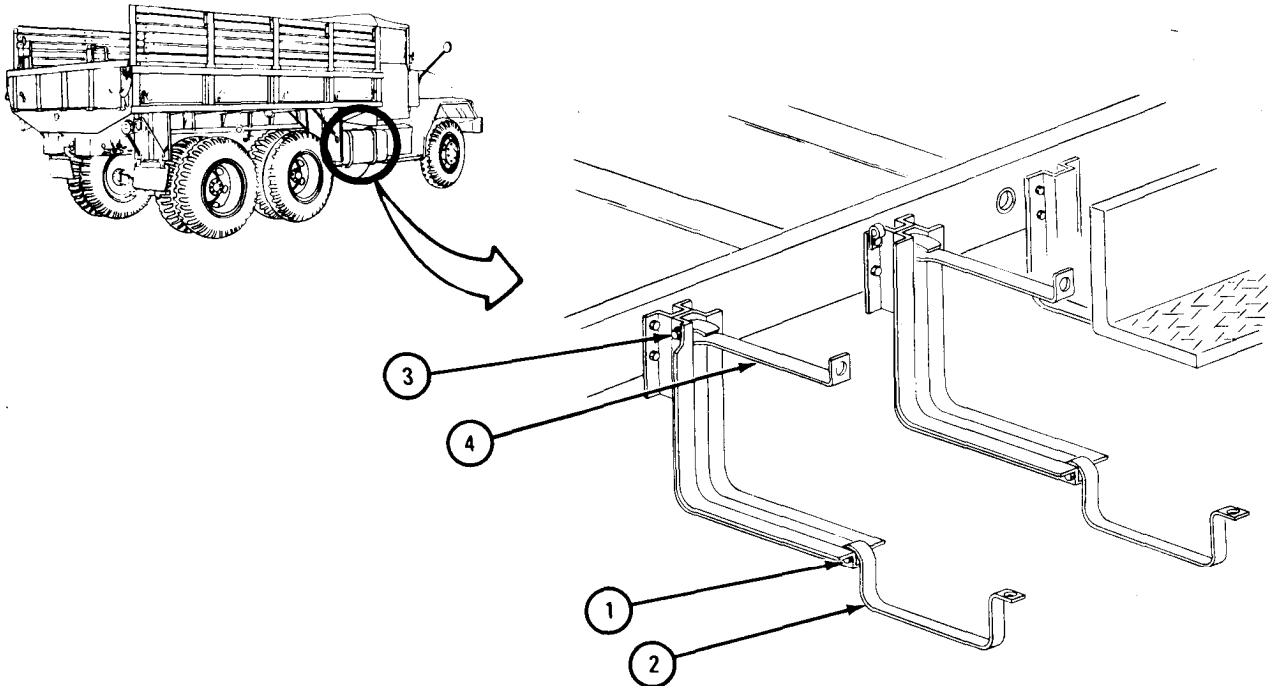

TA 085276

FRAME 2

1. Take off air line clamp (1) and ground wire (2).
 2. Take out four screws and nuts (3) from each of two brackets (4). Take off brackets.
- END OF TASK

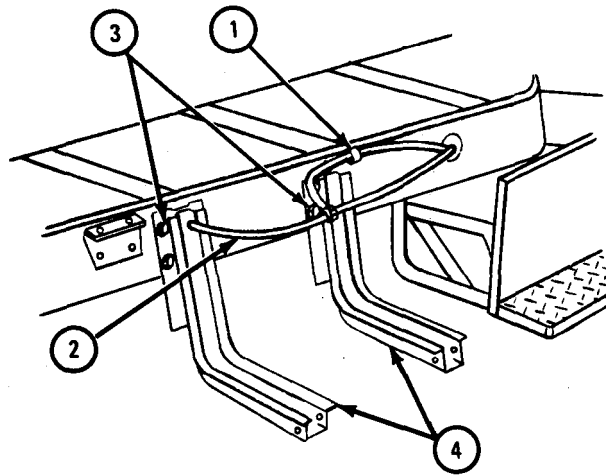

TA 085277

c. Replacement.

FRAME 1

1. Put front bracket (1) in place.
2. Align hole in air line clamp (2) with hole in front bracket (1). Put in four screws and nuts (3).

NOTE

On truck M342A2, put clip on inside of frame on same screws holding air line clamp (2).

3. Put rear bracket (4) in place.
4. Put in four screws and nuts (5). Make sure upper and lower rear screws go through muffler bracket on inside of frame.
5. Put on ground wire (6).

GO TO FRAME 2

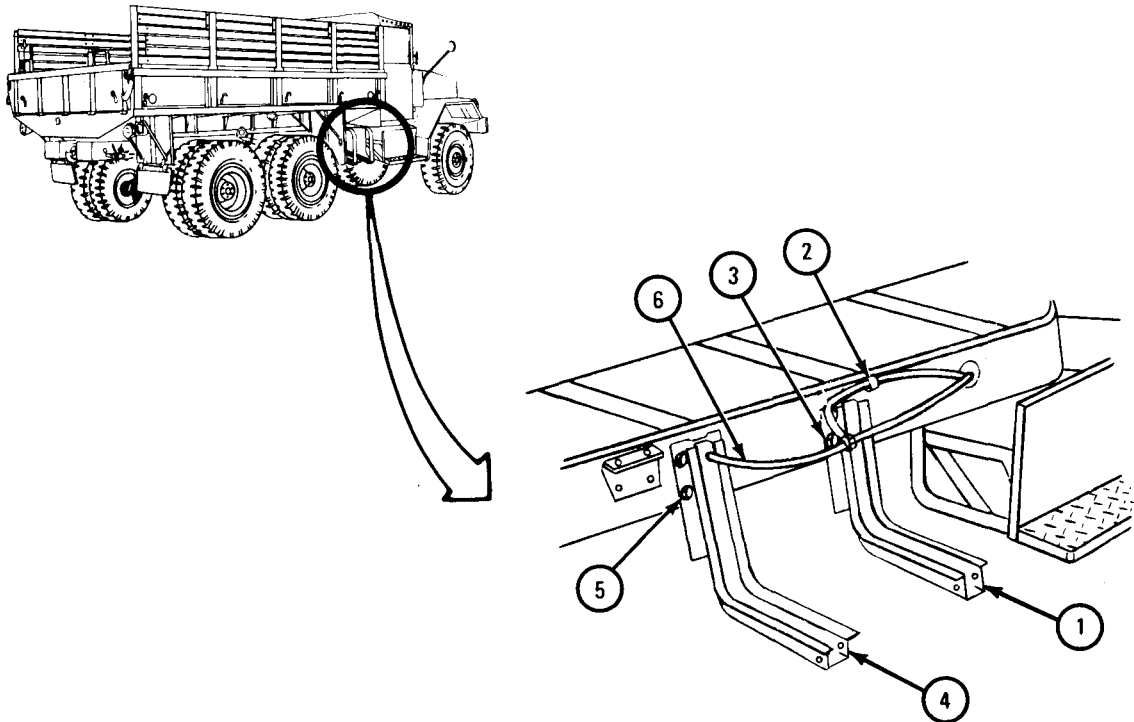

TA 085278

FRAME 2

1. Put in screw and nut (1) joining retaining bands (2) to bracket (3).
2. Put in screw and nut (4) joining fuel tank straps (5) to bracket (3). Do not tighten nut.

NOTE

Replace fuel tank. Refer to TM 9-2320-209-20.

END OF TASK

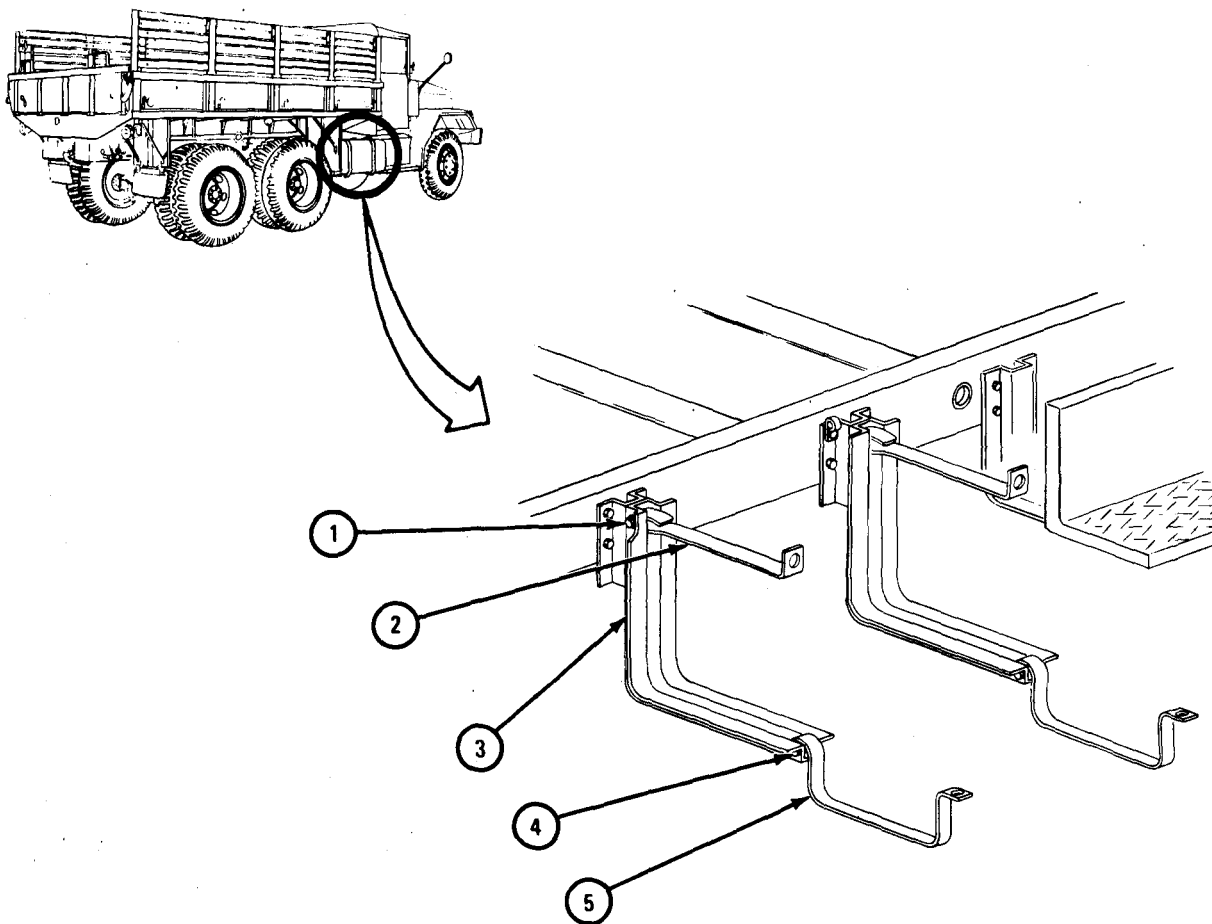

TA 085279

19-7. REAR BUMPERETTES REMOVAL AND REPLACEMENT (ALL TRUCKS EXCEPT TRUCKS M275A1, M275A2, AND M342A2).

TOOLS: No special tools required

SUPPLIES: None

PERSONNEL: One

EQUIPMENT CONDITION: Truck parked, engine off, handbrake set.

a. Preliminary Procedure. On trucks with trailer brake connectors mounted on the bumperette, remove quick-disconnect coupling half with bracket. Refer to TM 9-2320-209-20.

b. Removal.

FRAME 1

1. Take off two screws (1) and nuts (2). Move taillight assembly (3) out of the way.

2. Take off two bolts (4) and nuts (5). Take off bumperette (6).

END OF TASK

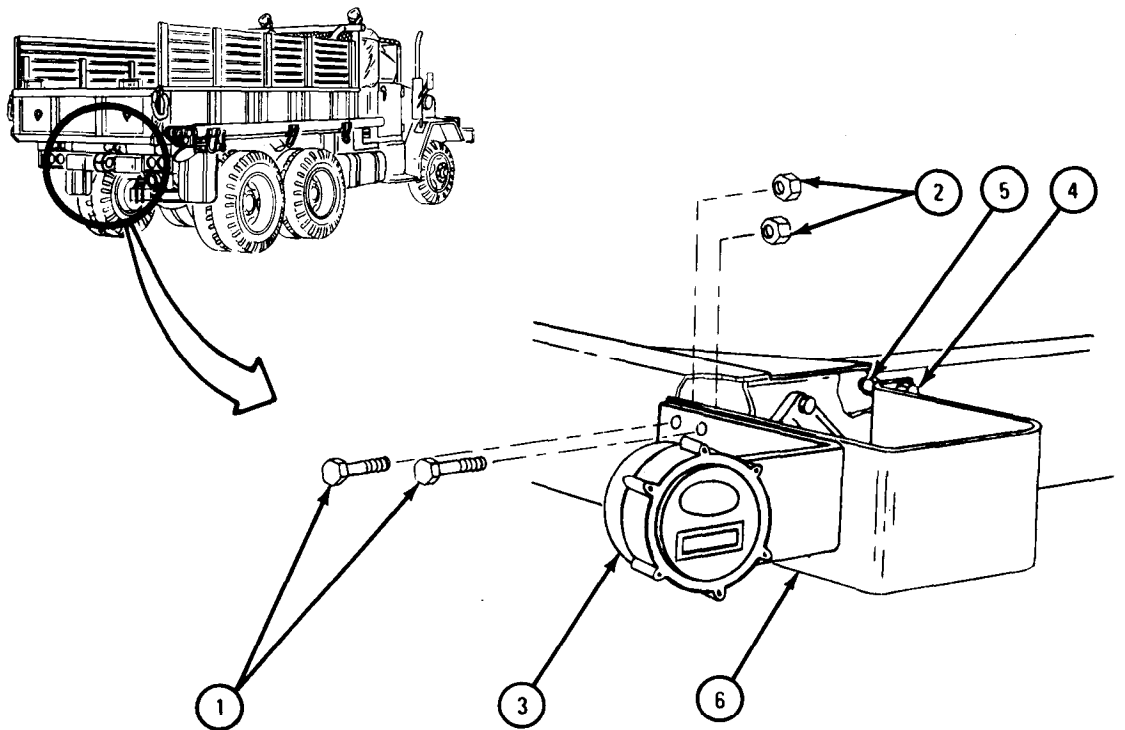

TA 085303

c. Replacement.

FRAME 1

1. Place bumperette (1) and put in two screws (3) and nuts (4).
2. Place taillight assembly (5) on bumperette (1) and put in two screws (6) and nuts (7).

NOTE

Follow-on Maintenance Action Required:

1. On trucks with trailer brake connectors mounted on the bumperette, replace quick-disconnect coupling half with bracket. Refer to TM 9-2320-209-20.

END OF TASK

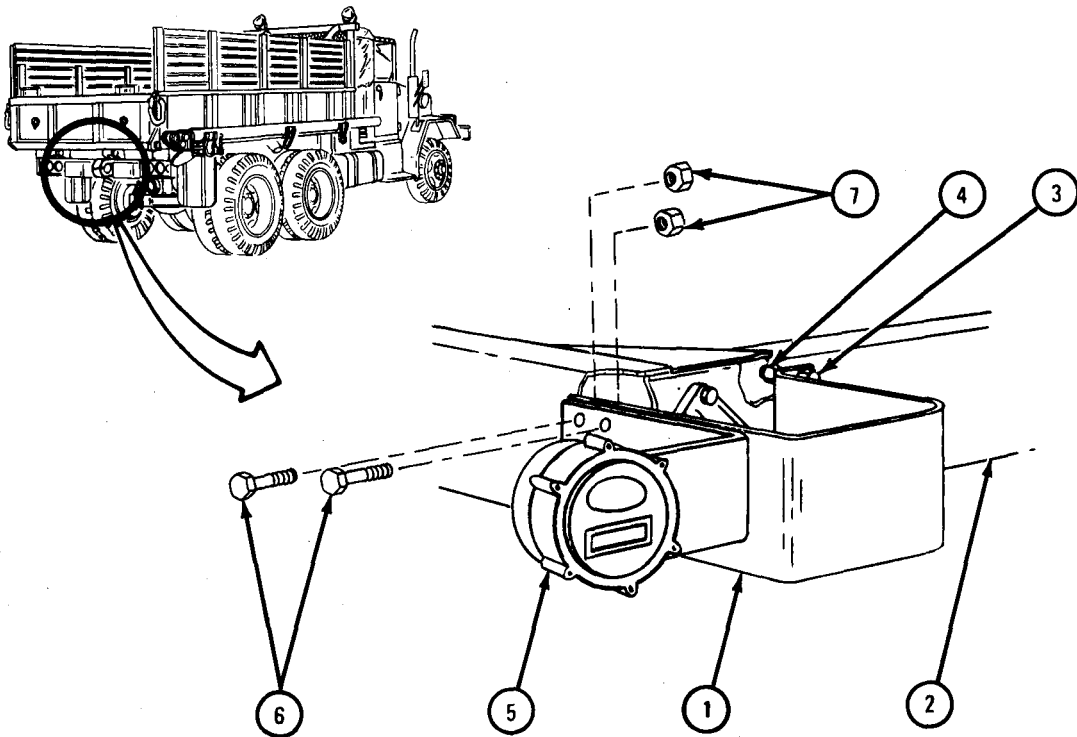

TA 085304

19-8. LAMP SUPPORT BRACKET REMOVAL, REPAIR AND REPLACEMENT
(EARLY MODEL TRUCKS).

NOTE

Task shown is for the right side. Task is the same for the left side.

TOOLS: No special tools required

SUPPLIES: Solvent, dry cleaning, type II (SD-2), Fed. Spec P-D-680
Clean rags

PERSONNEL: One

EQUIPMENT CONDITION: Truck parked, engine off, handbrake set.

a. Preliminary Procedures.

(1) Open hood. Refer to TM 9-2320-209-10.

(2) Take off brush guard. Refer to para 19-5.

(3) Remove side panel. Refer to Part 2, para 17-3.

(4) If working on left side, remove blackout drive light. Refer to
TM 9-2320-209-20.

(5) If working on right side, remove electrical horn. Refer to
TM 9-2320-209-20.

b. Removal.

FRAME 1

NOTE

Tag plugs (1) so they will be put back in the same places.

1. Unplug two electrical plugs (1) and ground wire (2).

GO TO FRAME 2

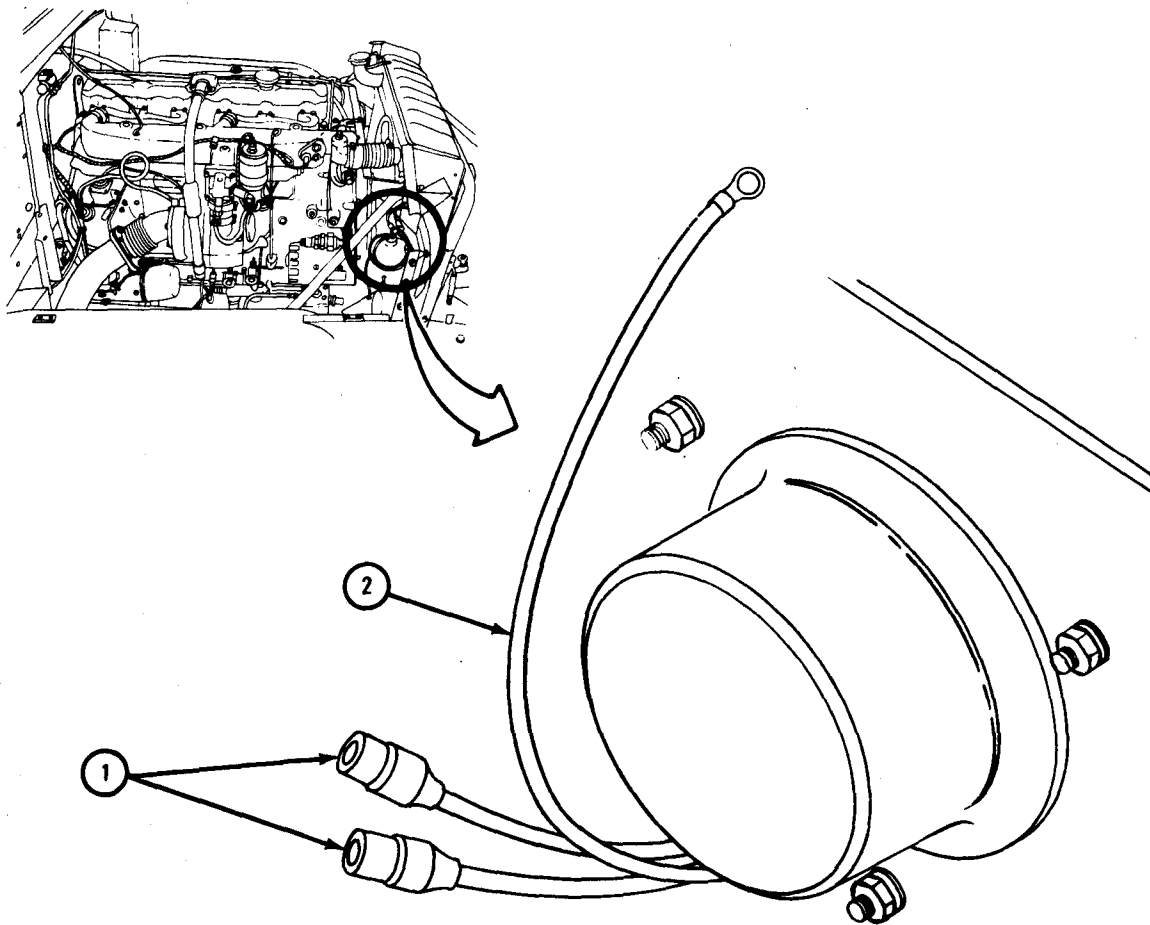

TA 101826

FRAME 2

1. Unscrew three screws (1) and remove headlamp door (2).
2. Take off six nuts (3), washers (4) and screws (5).
3. Take off lamp support bracket (6).

GO TO FRAME 3

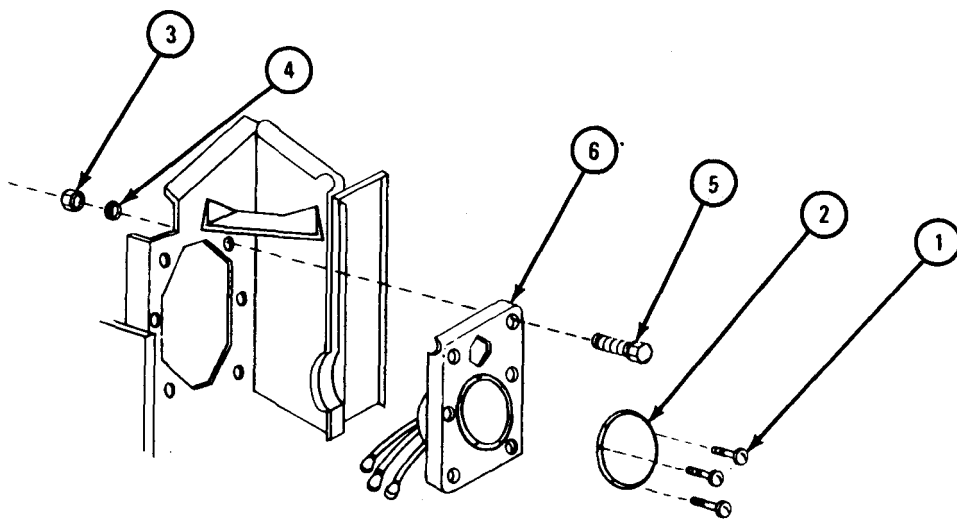

TA 118780

FRAME 3

NOTE

On some trucks nuts (3) may be spot welded to headlamp bracket (4). Washer (2) and nuts (3) are on back side of bracket (4).

1. Takeout eight screws (1), washers (2) and nuts (3).
2. Remove headlight assembly (4).

END OF TASK

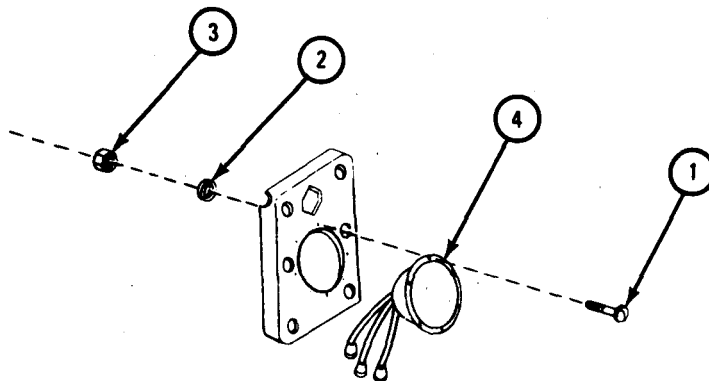

TA 118781

WARNING

Dry cleaning solvent is flammable. Do not use near an open flame. Keep a fire extinguisher nearby when solvent is used. Use only in well-ventilated places. Failure to do this may result in injury to personnel and damage to equipment.

- c. Cleaning. Clean all metal parts with dry cleaning solvent. Dry with clean rags.
- d. Inspection and Repair.

FRAME 1

1. Check that lamp support bracket (1) is not bent, dented, torn or cracked. To straighten bent or dented parts, refer to TM 10-450. To weld tears or cracks, refer to TM 9-237. If more repair is needed, get new parts.
2. Check that all threaded parts are not stripped or cross threaded.

END OF TASK

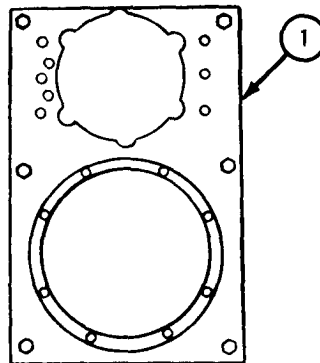

TA 101829

e. Replacement.

FRAME 1

NOTE

On some trucks nuts (5) may be spot welded to lamp support bracket (2). Washer (4) and nuts (5) are on back side of bracket (2).

1. Place headlamp assembly (1) into lamp support bracket (2).
2. Put in eight screws (3), washers (4) and nuts (5).

GO TO FRAME 2

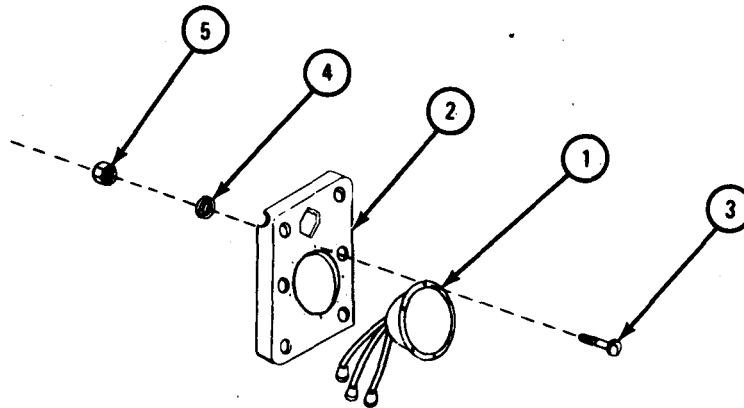

TA 118782

FRAME 2

1. Replace lamp support bracket (1).
 2. Replace headlamp door (2) and three screws (3).
 3. Replace six screws (4), washers (5) and nuts (6).
- GO TO FRAME 3

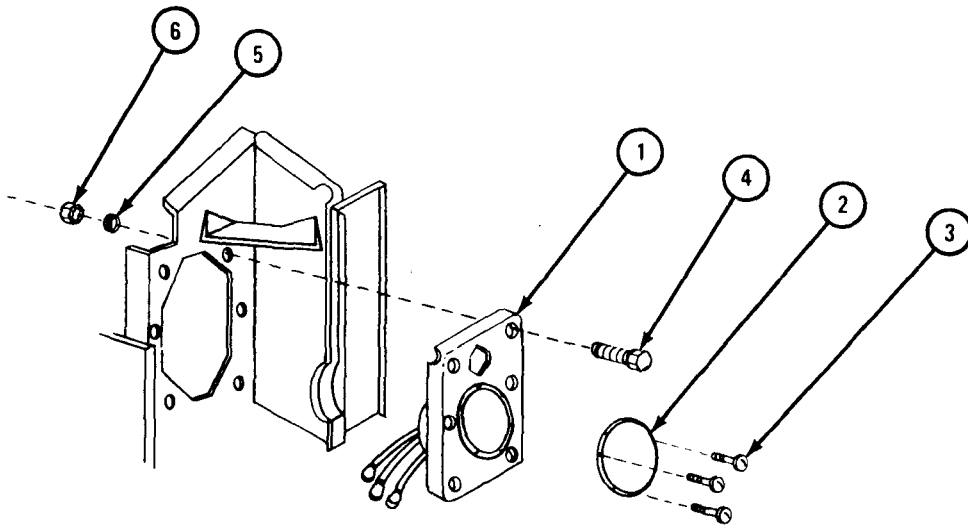

TA 118783

FRAME 3

1. Plug two electrical plugs (1) into headlamp wire (2).
2. Replace ground wire (3).

NOTE

Follow-on Maintenance Action Required:

1. If working on left side put on black out drive light. Refer to TM 9-2320-209-20.
2. If working on right side, put in electric horn. Refer to TM 9-2320-209-20.
3. Put on brush guard. Refer to para 19-5.
4. Put on side panel. Refer to Part 2, para 17-3.
5. Close hood. Refer to TM 9-2320-209-10.

END OF TASK

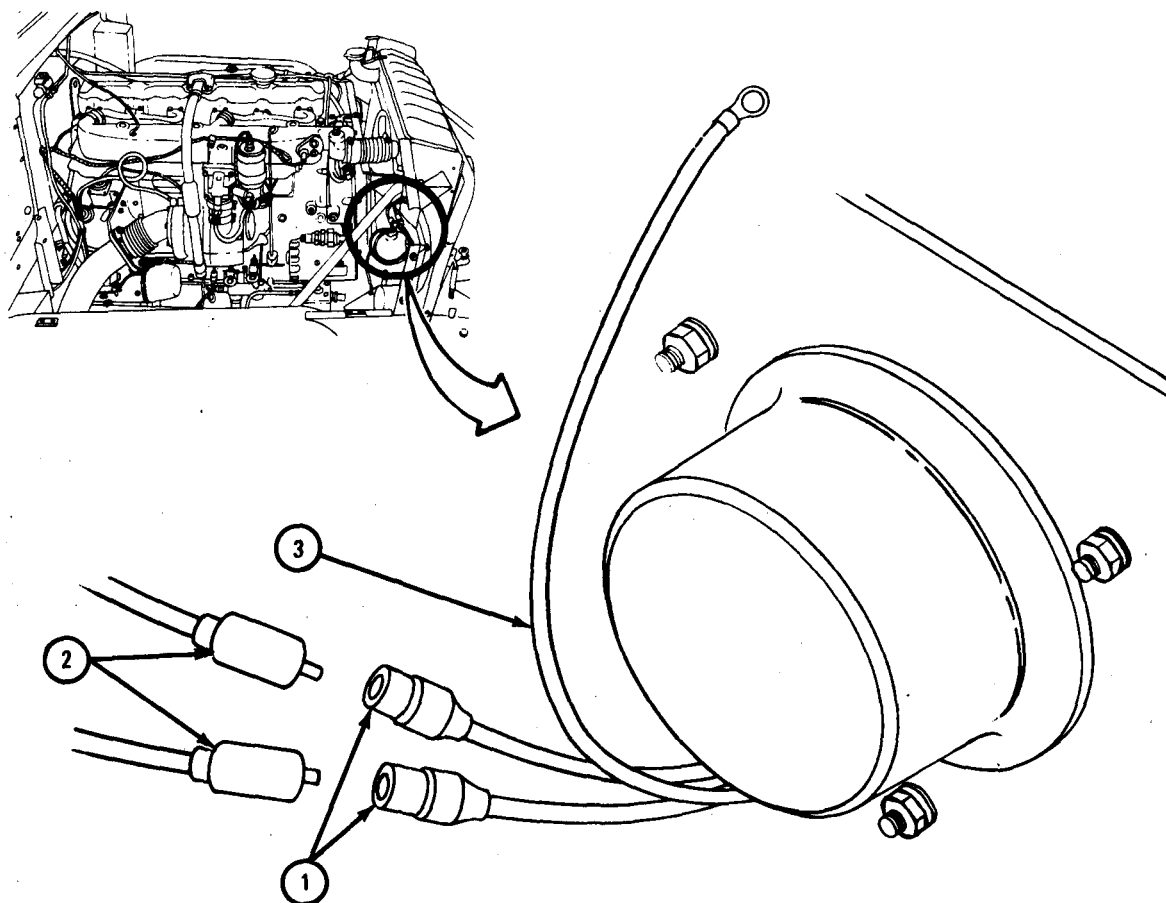

TA 101831

19-9. LAMP SUPPORT BRACKET REMOVAL, REPAIR, AND REPLACEMENT
(LATE MODEL TRUCKS).

NOTE

This task is the same for the left and right lamp support brackets. This task is shown for the right lamp support bracket.

TOOLS: No special tools required

SUPPLIES: Solvent, dry cleaning, type II (SD-2), Fed. Spec P-D-680
Clean rags
Tags

PERSONNEL: One

EQUIPMENT CONDITION: Truck parked, engine off, handbrake set.

a. Preliminary Procedures.

(1) Open hood. Refer to TM 9-2320-209-10.

(2) Remove brush guard. Refer to para 19-5.

(3) Remove side panel. Refer to Part 2, para 17-3.

(4) If working on left lamp support bracket, remove blackout drive light.
Refer to TM 9-2320-209-20.

b. Removal.

FRAME 1

1. Loosen three screws (1) and take off headlight mounting ring (2).

NOTE

Tag three wires (3) so they will be put back in the same places.

2. Pull out sealed beam (4) and unplug three connectors (5).

GO TO FRAME 2

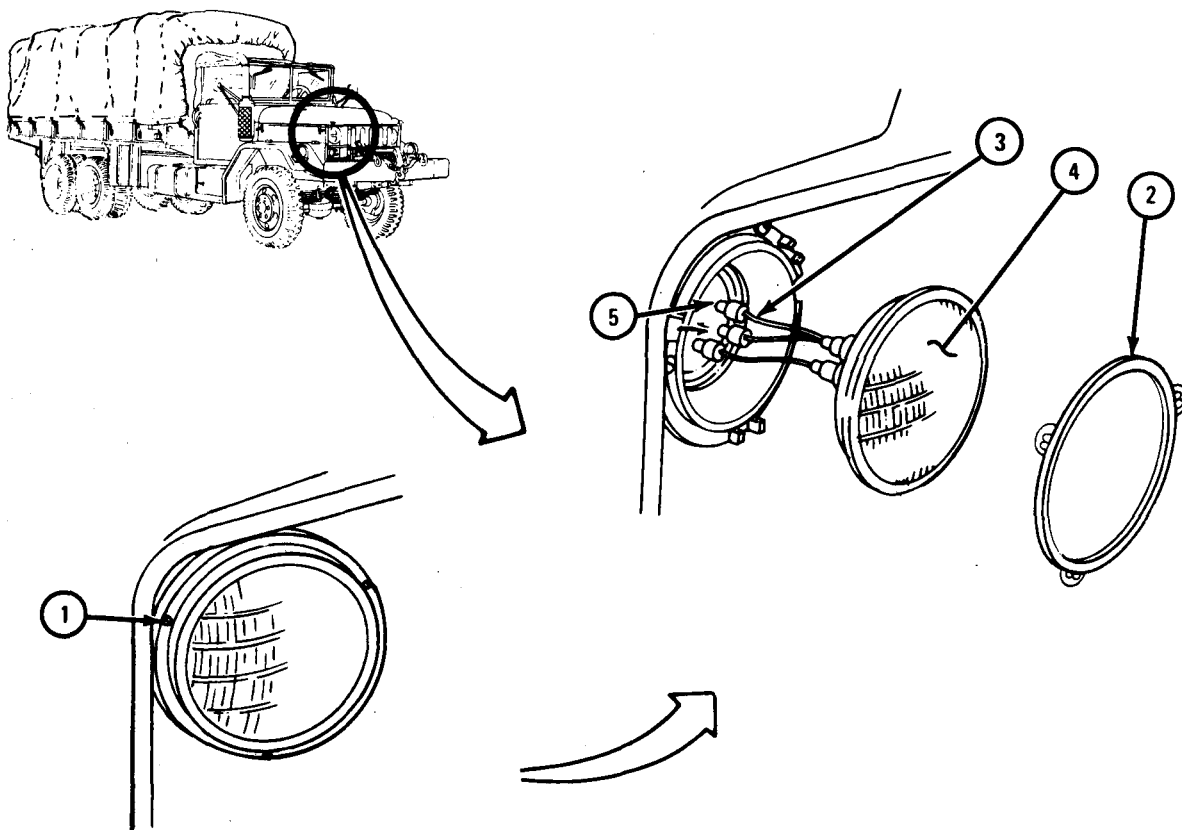

TA 101155

FRAME 2

1. Take out two screws and lockwashers (1).
2. Take off panel brace (2).

GO TO FRAME 3

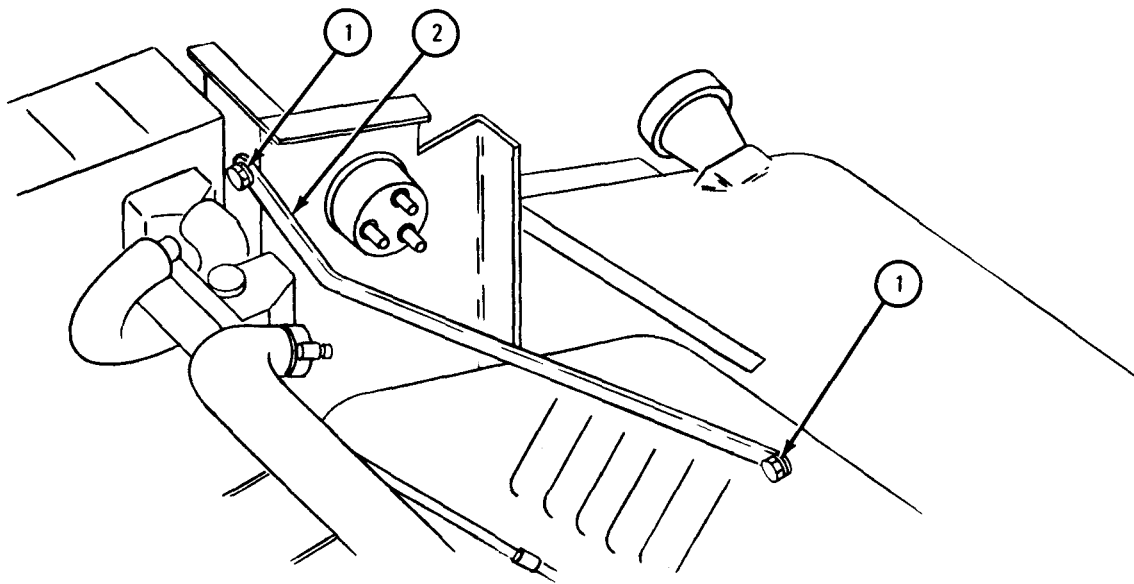

TA 101156

FRAME 3

1. Unplug three wires (1).
2. Takeout screw, washer, and nut (2). Take off clamp (3).

GO TO FRAME 4

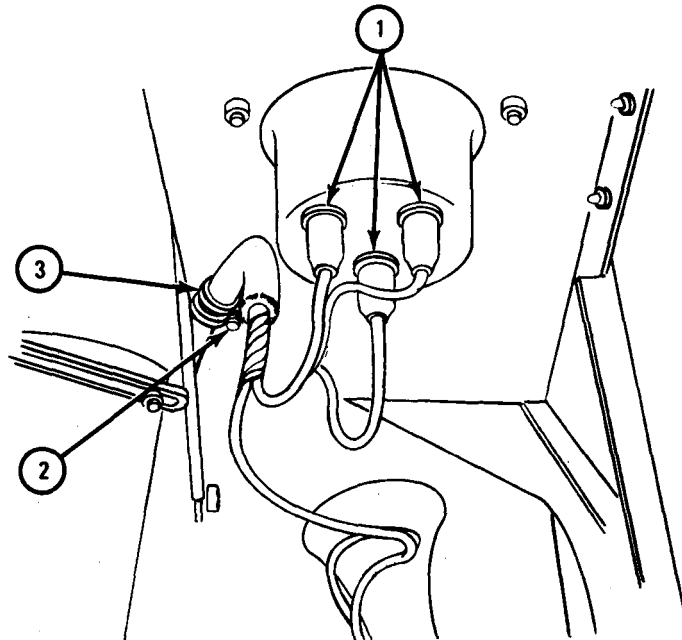

TA 101157

FRAME 4

1. Take out three screws with washers (1) and three nuts (2).
2. Take out two screws (3) and nuts (4).
3. Take off bracket (5).

END OF TASK

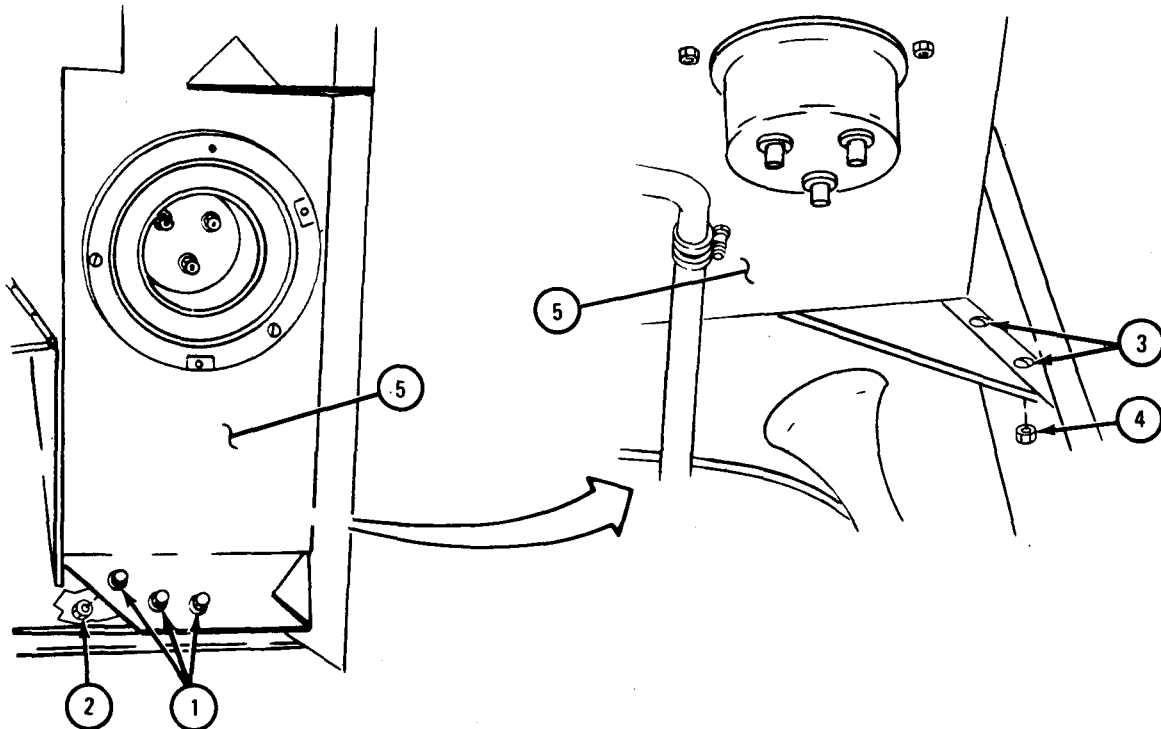

TA 101158

c. Cleaning. There are no special cleaning procedures needed. Refer to cleaning procedures given in Part 1, para 1-3.

d. Inspection and Repair.

FRAME 1

1. Check that bracket (1), panel brace (2) and clamp (3) are not bent, dented, torn or cracked.
2. Straighten bent or dented parts. Refer to TM 9-237. If more repair is needed, get new parts.
3. Check that nuts and screws do not have damaged threads and are not damaged in any other way. If parts are damaged, get new ones.

END OF TASK

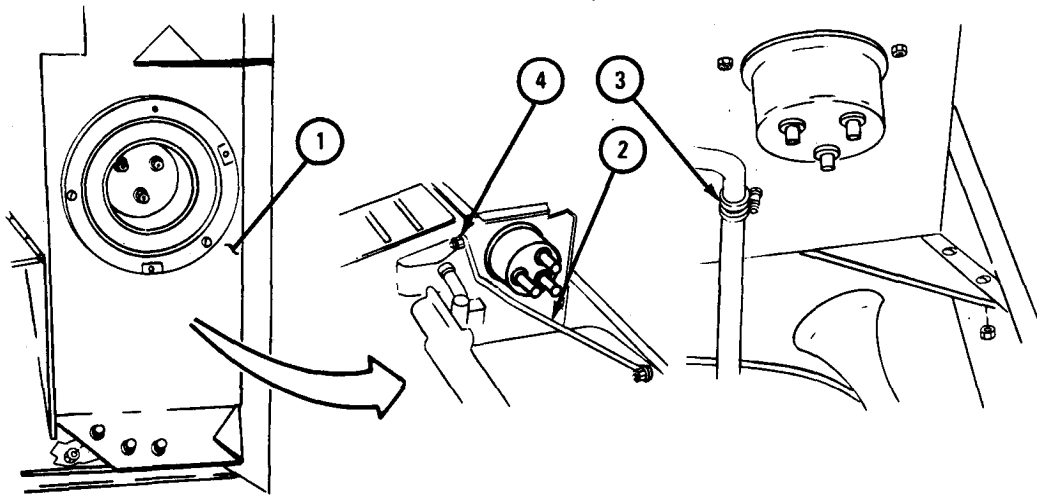

TA 101159

e. Replacement.

FRAME 1

1. Put lamp support bracket (1) in place.
2. Put in three screws with washers (2) and three nuts (3).
3. Put in two screws (4) and two nuts (5).

GO TO FRAME 2

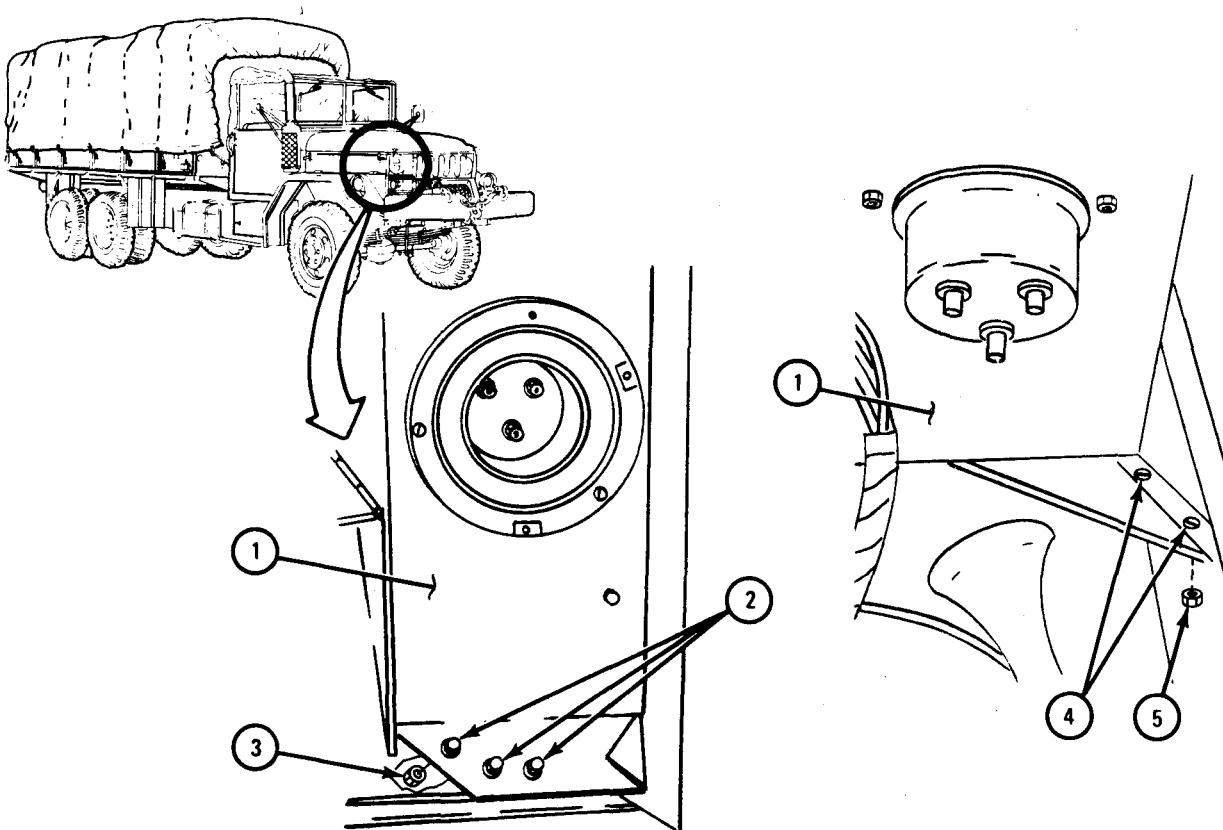

TA 101160

FRAME 2

1. Plug in three wires (1).
2. Put on clamp (2) and put in screw with washer (3) and nut (4).

GO TO FRAME 3

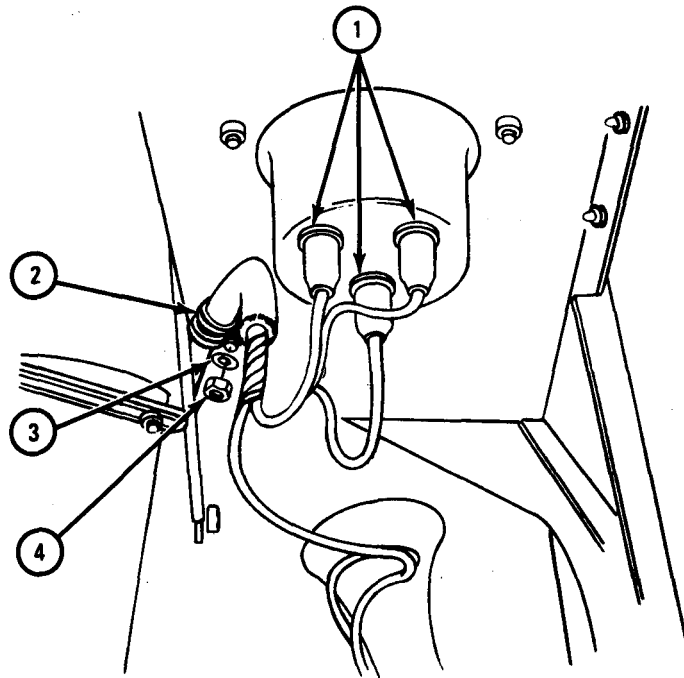

TA 101161

FRAME 3

1. Put panel brace (1) in place and put in two screws with lockwashers (2).
GO TO FRAME 4

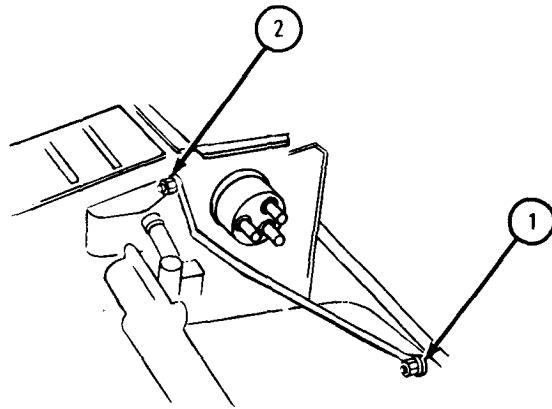

TA 101162

FRAME 4

1. Plug in three connectors (1) as tagged and take off tags. Put in sealed beam (2).
2. Hold sealed beam (2) in place. Put on mounting ring (3) and tighten three screws (4).

NOTE

Follow-on Maintenance Action Required:

1. If working on left lamp support bracket, replace blackout drive light. Refer to TM 9-2320-209-20.
2. Put on side panel. Refer to Part 2, para 17-3.
3. Put on brush guard. Refer to para 19-5.
4. Close hood. Refer to TM 9-2320-209-10.

END OF TASK

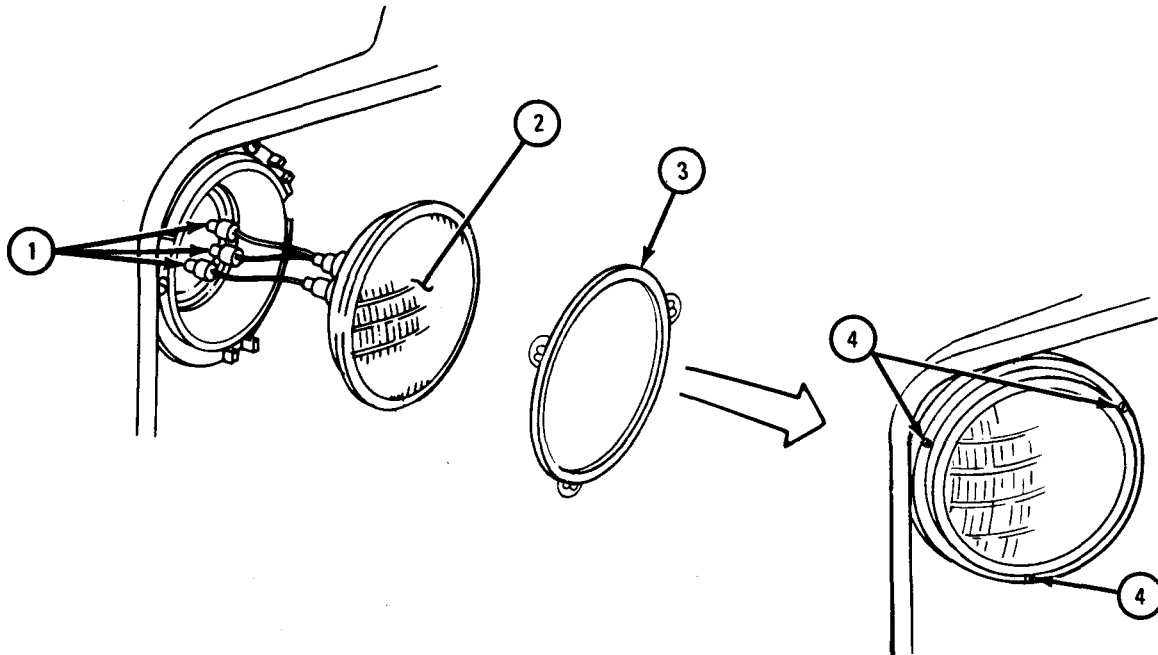

TA 101163

CHAPTER 20

BODY ACCESSORY ITEMS GROUP MAINTENANCE

Section I. SCOPE

20-1. EQUIPMENT ITEMS COVERED. This chapter gives equipment maintenance procedures for canvas and rubber items for which there are authorized corrective maintenance tasks at the direct and general support maintenance levels.

20-2. EQUIPMENT ITEMS NOT COVERED. All equipment items for which corrective maintenance is authorized at the direct and general support maintenance levels are covered in this chapter.

Section II. CANVAS AND RUBBER ITEMS

20-3. BODY COVER REPAIR. Refer to General Repair of Tents, Canvas, and Webbing, FM 43-3 for procedure to repair body cover.

20-4. BODY CURTAIN REPAIR. Refer to General Repair of Tents, Canvas, and Webbing, FM 43-3 for procedure to repair body curtain.

20-5. WATER DISPENSER HOSE REPAIR.

TOOLS: No special tools required

SUPPLIES: Soapy water

PERSONNEL: One

EQUIPMENT CONDITION: Truck parked, engine off, handbrake set.

a. Preliminary Procedures.

(1) Remove water dispenser hose. Refer to TM 9-2320-209-10.

(2) Remove water dispenser hose dispenser nozzle. Refer to Hose and Nozzle Assembly Removal and Replacement, TM 9-2320-209-20.

b. Cleaning. Clean hose with soapy water. Rinse well with clean water.

c. Inspection and Repair.

FRAME 1

1. Check that two couplings (1) have no cracks.
2. Check that hose (2) has no cuts, tears, holes or other damage.
3. If hose is damaged, get a new one.

NOTE

Follow-on Maintenance Action Required:

1. Replace water dispenser hose dispenser nozzle. Refer to Hose and Nozzle Assembly Removal and Replacement, TM 9-2320-209-20.
2. Replace water dispenser hoses. Refer to TM 9-2320-209-10.

END OF TASK

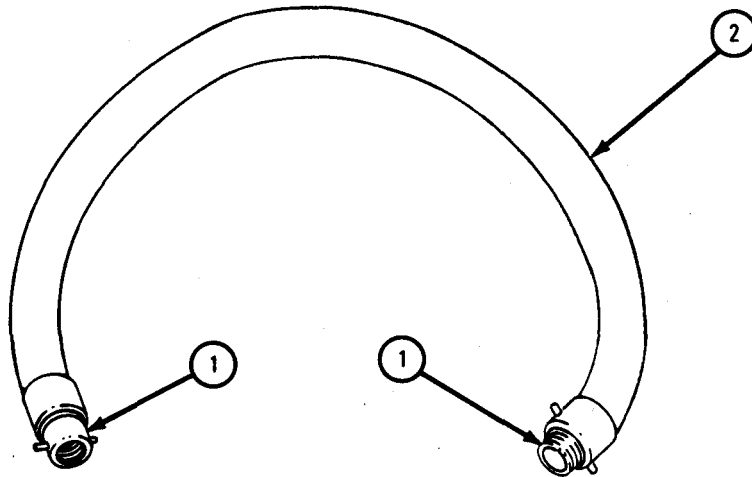

TA 085497

CHAPTER 21

MAINTENANCE OF MATERIAL USED IN CONJUNCTION WITH MAJOR ITEMS

Section I. SCOPE

21-1. EQUIPMENT ITEMS COVERED. This chapter gives equipment maintenance procedures for winterization kits, deep water fording, and special purpose kits for which there are authorized corrective maintenance tasks at the direct and general support maintenance levels.

21-2. EQUIPMENT ITEMS NOT COVERED. All equipment items for which corrective maintenance is authorized at the direct and general support maintenance levels are covered in this chapter.

Section II. WINTERIZATION KITS

21-3. HOT WATER PERSONNEL HEATER KIT INSTALLATION. Install the kit using the instructions that come with the kit.

21-4. ENGINE HEATER KIT INSTALLATION. Install the kit using the instructions that come with the kit.

21-5. POWERPLANT HEATER TEST.

TOOLS: No special tools required

SUPPLIES: None

PERSONNEL: One

EQUIPMENT CONDITION: Truck parked, engine off, handbrake set.

- a. Preliminary Procedure. Remove power plant heater. Refer to para 21-6.
- b. Testing.

WARNING

Smoking, sparks or open flames are not allowed within 50 feet of work area during this task. Fuel can explode, causing injury to personnel and damage to equipment.

Exhaust gases of any fuel are very poisonous. Be sure exhaust is directed out of work area. Be sure work area is well ventilated. Failure to do so could result in injury or death to personnel.

CAUTION

Be sure test stand is equipped with proper control box. Proper control box is pn G-701633. Damage to equipment will result if improper control box is used. Test stand must also be equipped with a coolant container of about five-gallon capacity. Container should be higher than heater. Container must be vented. Coolant used must be of same type as used in engine. Pure water cannot be used. Failure to use proper coolant could cause overheating and improper operation of thermostats, damaging heater.

NOTE

A fuel burning coolant heater test stand and stop watch is needed to perform these tests. Such a test stand can be fabricated. Refer to ST 9-194.

- (1) Fuel control valve.

CAUTION

Fuel flow and leak tests must be done with fuel control valve in the position it normally operates. Fuel used must be of the type normally used. Failure to do this could result in a wrong measurement, causing serious damage to equipment.

FRAME 1

NOTE

If fuel control valve (1) is already off heater, skip step 1.

1. Take fuel control valve (1) off heater. Refer to para 21-6c, frame 1, frame 4, and frame 5.
2. Connect fuel supply line (2) to fuel inlet fitting (3).
3. Using a suitable electrical lead (4), connect shutoff electrical lead (5) and restrictive electrical lead (6) together. Connect other end of lead (4) to pin B (7) of wiring harness connector (8).
4. Using another suitable electrical lead (9), connect body of fuel control valve (1) to pin A (10) of wiring harness connector (8).

GO TO FRAME 2

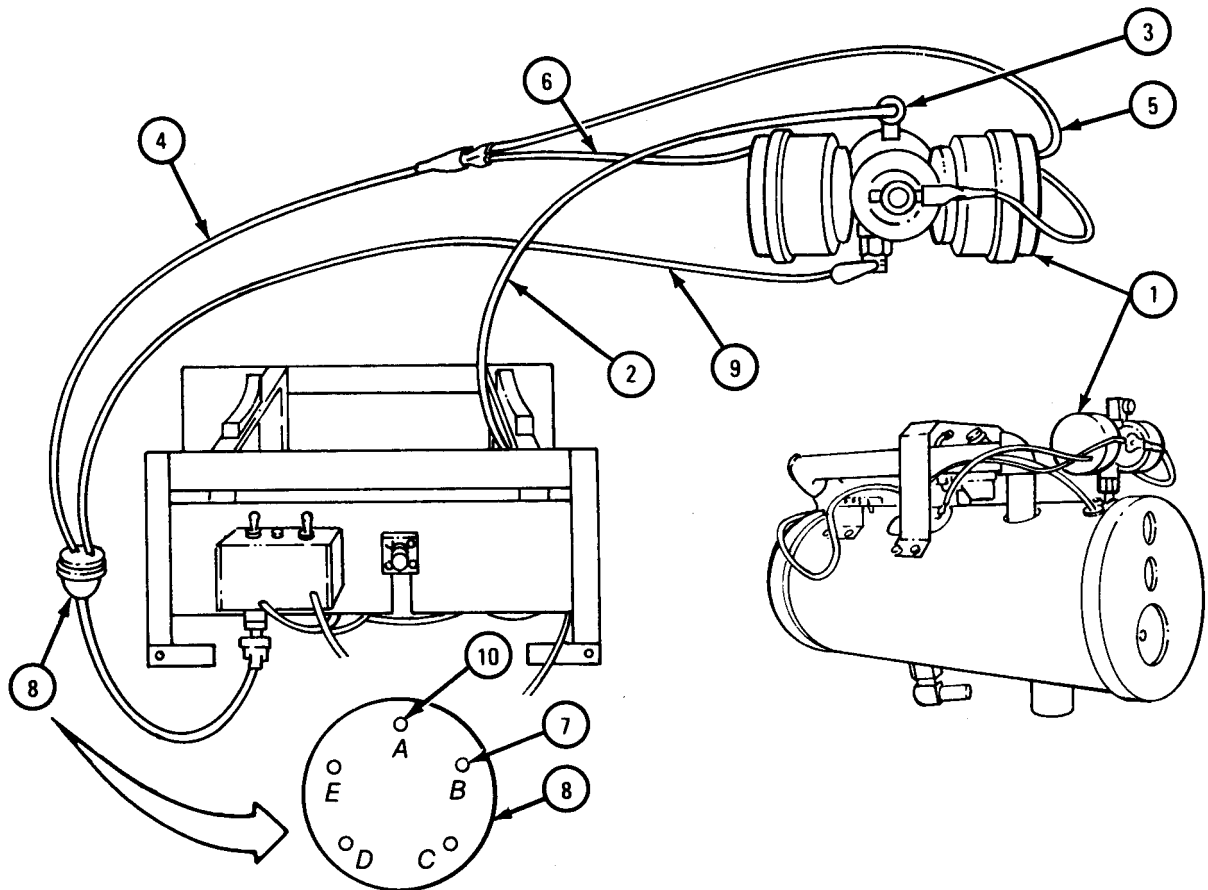

TA 104174

FRAME 2

1. Put control switch (1) in OFF position. Put HI-LO switch (2) in LO position.
2. Connect power supply lead (3) to plus (+) battery terminal (4). Connect ground lead (5) to minus (-) battery terminal (6).

GO TO FRAME 3

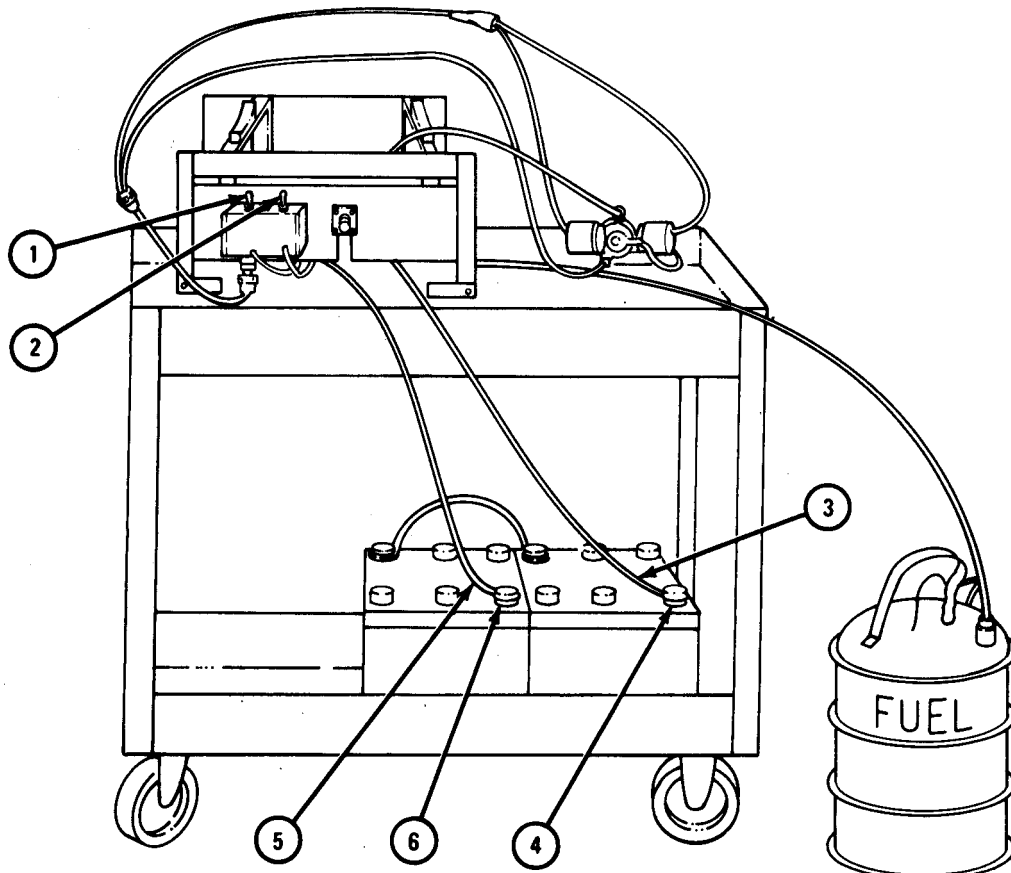

TA 104175

FRAME 3

NOTE

A suitable container (3) to catch overflow is needed for this test.

1. Hold fuel outlet (1) of fuel control valve (2) over overflow container (3).
2. Be sure HI-LO switch (4) is in LO position. Flip control switch (5) to RUN position. Fuel pump should be pumping.
3. Flip HI-LO switch (4) to HI. Let fuel flow into overflow container (3) for a few seconds. Flip HI-LO switch (4) to LO.
4. Look at fuel outlet (1) for one minute. One or two drops may form, but fuel flow must be completely stopped.
5. Do steps 1 through 4 again. Flip control switch (5) to OFF position.
6. If fuel flow does not stop completely when HI-LO switch (4) is flipped to LO, get a new fuel control valve.

IF FUEL CONTROL VALVE PASSES TEST, GO TO FRAME 4.

IF FUEL CONTROL VALVE FAILS TEST, GO TO FRAME 6

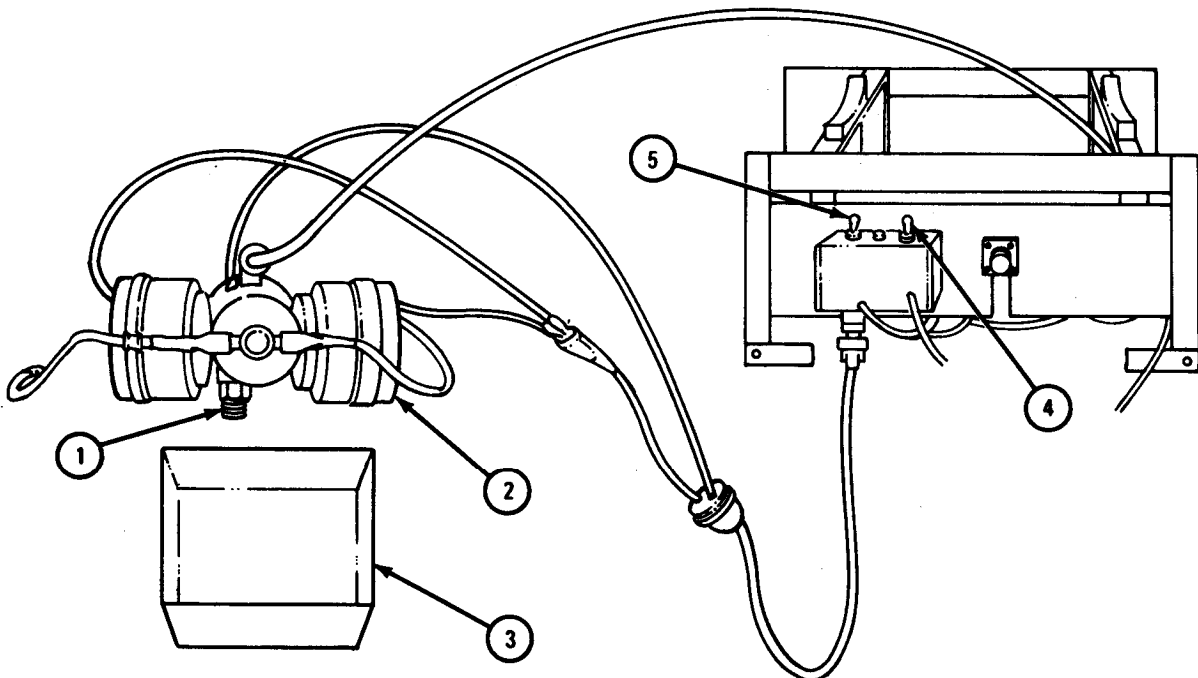

TA 104177

FRAME 4

NOTE

Fuel flow test and adjustment should be done even on a new fuel control valve. Fuel control valve must be adjusted for use with different fuels. A stop watch or watch with a second hand is needed for this test.

1. Hold fuel outlet (1) of fuel control valve (2) over overflow container (3).
2. Be sure HI-LO switch (4) is in LO position. Flip control switch (5) to RUN position. Fuel pump should be pumping.
3. Flip HI-LO switch (4) to HI. Let fuel flow into overflow container (3) for a few seconds.
4. Let fuel flow into graduate (6) for exactly one minute. Flip HI-LO switch (4) to LO. Flip control switch (5) to OFF position.
5. Place graduate (6) on a level surface. Read level of fuel (7) as shown. Level of fuel should be as in table for type of fuel used.

FUEL TYPE	Diesel Fuel			Combat Gasoline
	DFA	DF1	DF2	
Flow Rate (cc/mm)	14 to 18	14 to 18	15 to 19	15 to 19

6. If fuel flow is not within range of table, get a new fuel control valve (2).

GO TO FRAME 5

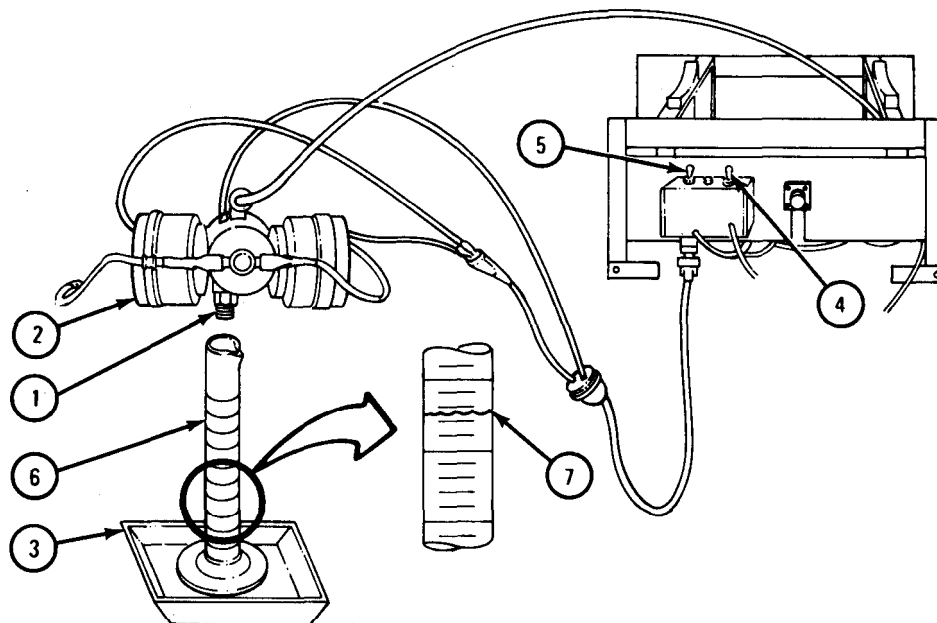

TA 104178

FRAME 5

1. Take restrictive electrical lead (1) out of clip (2).
2. Hold fuel outlet (3) of fuel control valve (4) over overflow container (5).
3. Be sure HI-LO switch (6) is in LO position. Flip control switch (7) to RUN position. Fuel pump should be pumping.
4. Flip HI-LO switch (6) to HI. Let fuel flow into overflow container (5) for a few seconds.
5. Let fuel flow into graduate (8) for exactly one minute. Flip HI-LO switch (6) to LO. Flip control switch (7) to OFF position.
6. Place graduate (8) on a level surface. Read level of fuel (9) as shown. Level of fuel should be as in table for type of fuel used.

FUEL TYPE	Diesel Fuel			Combat Gasoline
	DFA	DF1	DF2	
Flow Rate (cc/mm)	6 to 8	6.5 to 8.5	6.5 to 8.5	7 to 9

7. If fuel flow is not within range of table, get a new fuel control valve (4).
GO TO FRAME 6

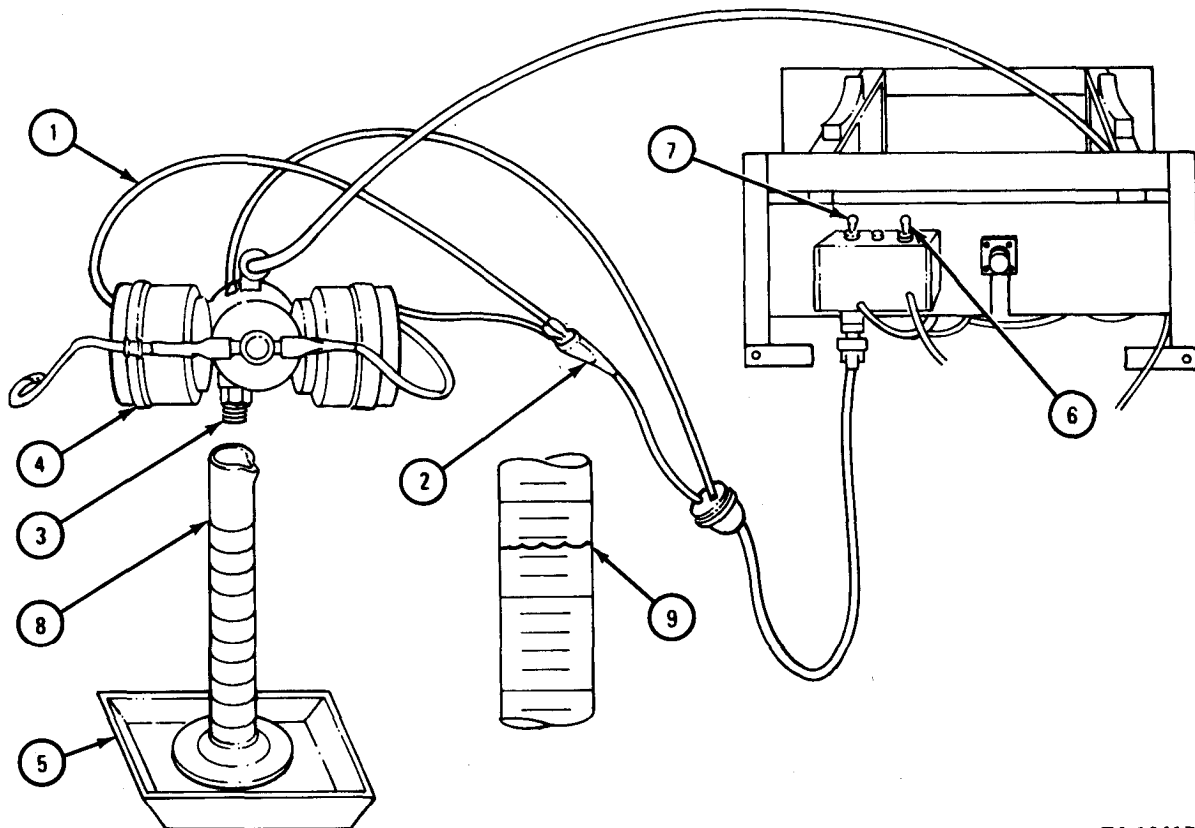

TA 104179

FRAME 6

1. Take off electrical lead (1) from fuel control valve body (2) and from pin A (3) of wiring harness connector (4).
2. Take off electrical lead (5) from fuel control valve leads (6) and from pin B (7) of wiring harness connector (4).
3. Take off fuel supply line (8) from fuel inlet fitting (9).

NOTE

If these tests on fuel control valve were done as part of cleaning, inspection, and repair, skip step 4, go to para 21-6d (5), frame 2.

4. Put fuel control valve (2) on heater (10). Refer to para 21-6e, frame 8, frame 9, and frame 12.

END OF TASK

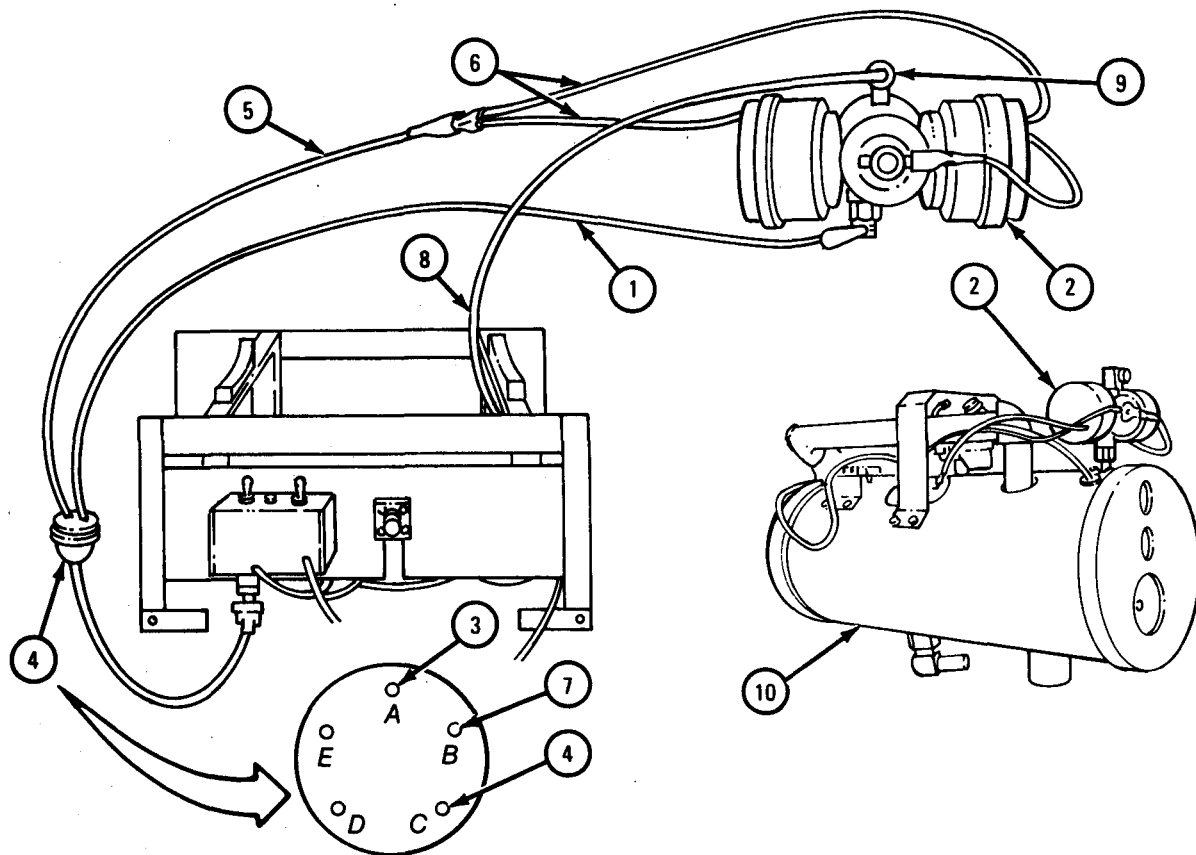

TA 104180

(2) Testing set-up.

FRAME 1

1. Mount heater assembly (1) on test stand (2).
 2. Connect coolant inlet hose (3) and outlet hose (4) to heater (1). Connect exhaust pipe (5).
 3. Connect fuel supply line (6) to fuel inlet fitting (7).
 4. Connect wiring harness (8) to electrical connector (9).
- GO TO FRAME 2

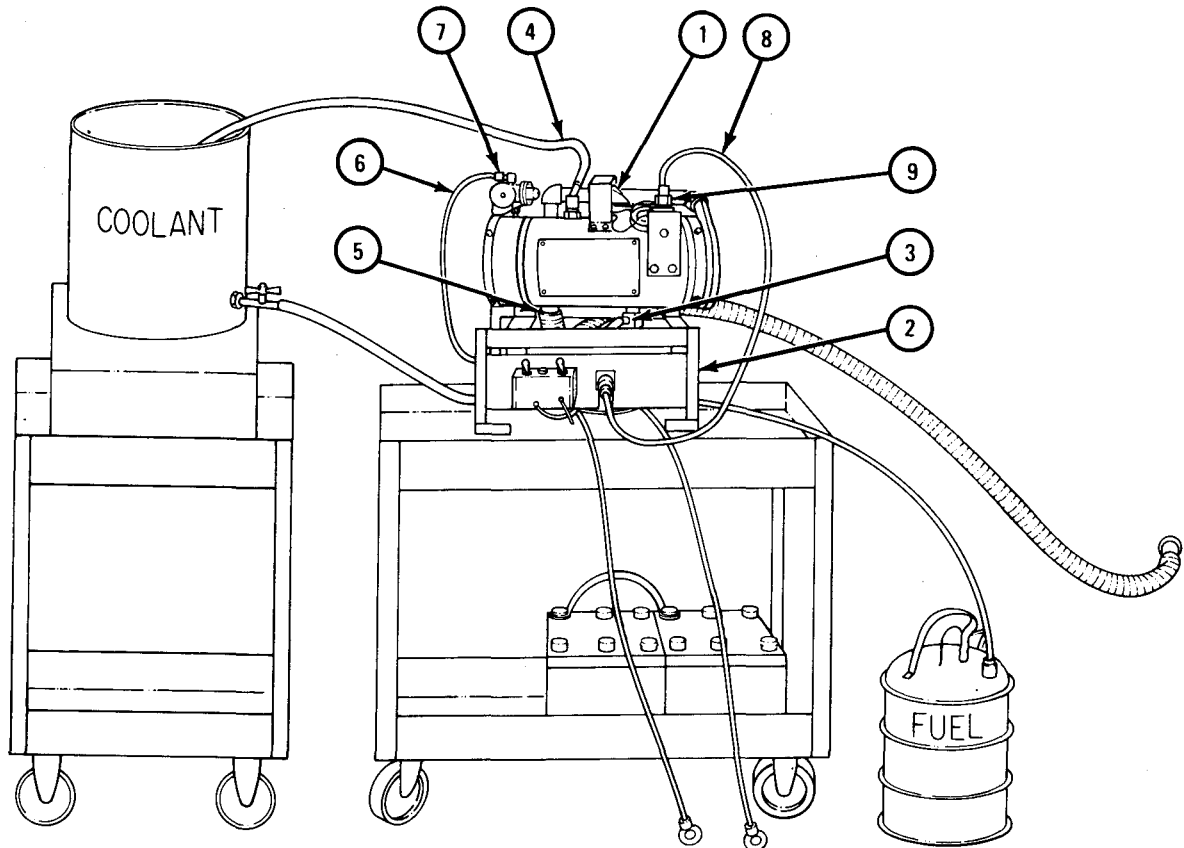

TA 104172

FRAME 2

1. Put control switch (1) in OFF position. Put HI-LO switch (2) in LO position. Fill coolant container (3) with coolant.
2. Take off end cover plate (4). Refer to para 21-6c, frame 6.
3. Inspect inside of heater (5) for coolant leaks. If leaks are found, stop testing. Take heater (5) apart. Refer to para 21-6c.
4. Connect power supply lead (6) to plus (+) battery terminal (7). Connect ground lead (8) to minus (-) battery terminal (9).

END OF TASK

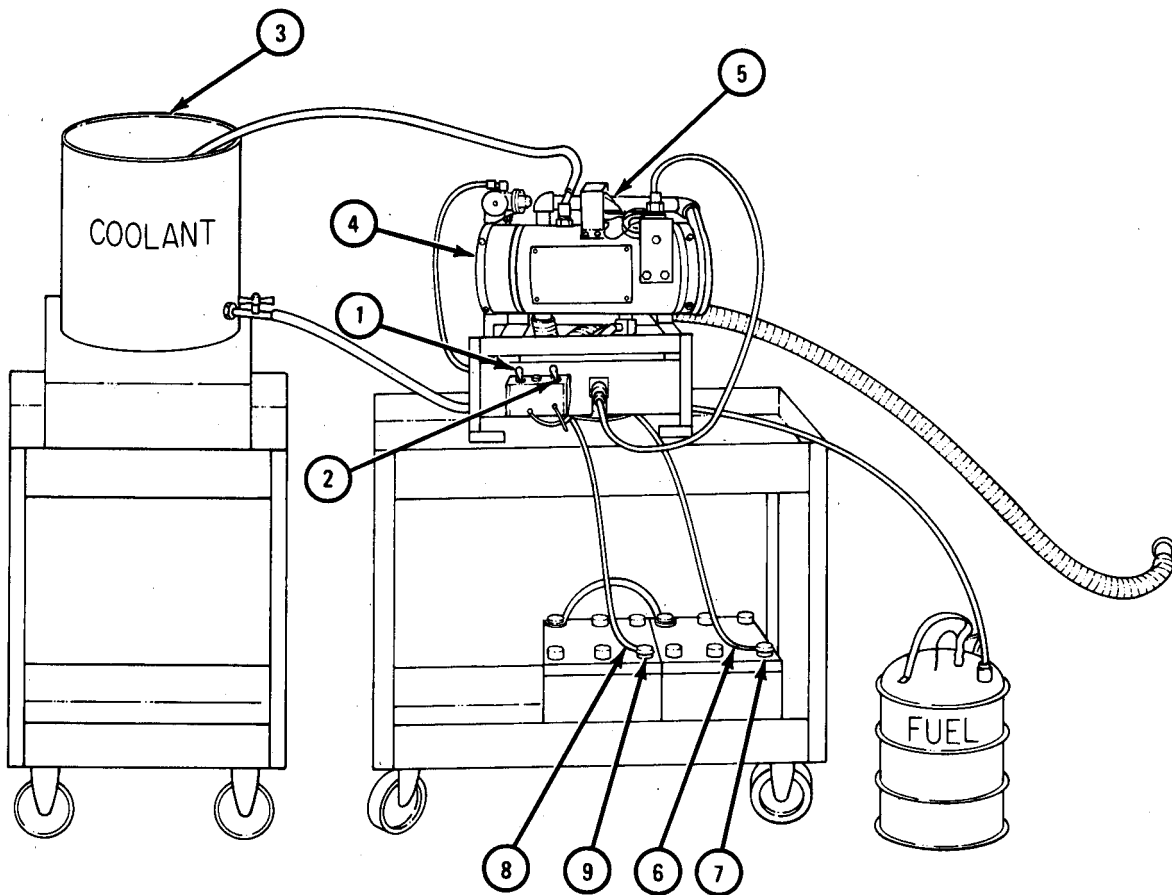

TA 104173

(3) Burn test.

FRAME 1

1. Be sure control switch (1) is in OFF position. Flip HI-LO switch (2) to HI.
2. Start timing and hold control switch (1) in START position. Heater (3) should start in 40 seconds. Flip control switch (1) to RUN.
3. If heater (3) does not start, replace igniter. Refer to para 21-6c, and para 21-6e.
4. Look inside heater (3) for fuel leaks. If leaks are found, stop testing. Repair leak, refer to para 21-6c, para 21-6d, and para 21-6e.
5. Flame detector switch should transfer in 200 seconds. Pilot lamp (4) will glow when transfer takes place.
6. If transfer does not take place, adjust or get new flame detector switch. Refer to para 21-6c, 21-6d, and 21-6e.
7. Let heater (3) burn on HI heat for about a minute. Flip HI-LO switch (2) to LO. Burning should be less and blower motor should run slower.
8. If heater (3) goes out, a new fuel control valve must be put on. Refer to para 21-6c and 21-6d. Then do this frame again.
9. Flip control switch (1) to OFF position. Fuel flow should stop; burning should stop in 30 seconds. Blower should still run for more than one minute, but less than three minutes. Blower should stop all by itself.
10. If blower does not run as in step 9, do step 6.

END OF TASK

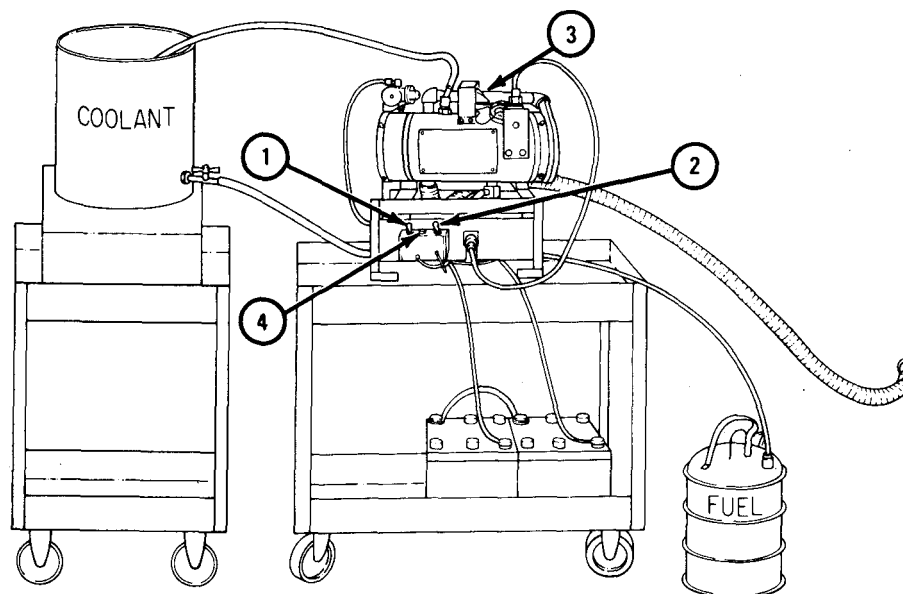

TA 104181

(4) Cycling test.

FRAME 1

1. Be sure control switch (1) is in OFF position. Flip HI-LO switch (2) to HI position. Start heater (3) and let it run until it transfers to LO heat all by itself.
2. Wait a few minutes after heater (3) transfers to LO heat. Measure temperature of coolant at outlet hose (4) by letting coolant run on thermometer.

WARNING

Coolant will be hot. Use caution when working near hot coolant. Severe burns could result.

3. Temperature should be between 170°F and 195°F.
4. Flip control switch (1) to OFF position. Let blower motor stop.
5. If temperature is not as specified, get new restriction thermostat. Refer to para 21-6c and para 21-6e.

END OF TASK

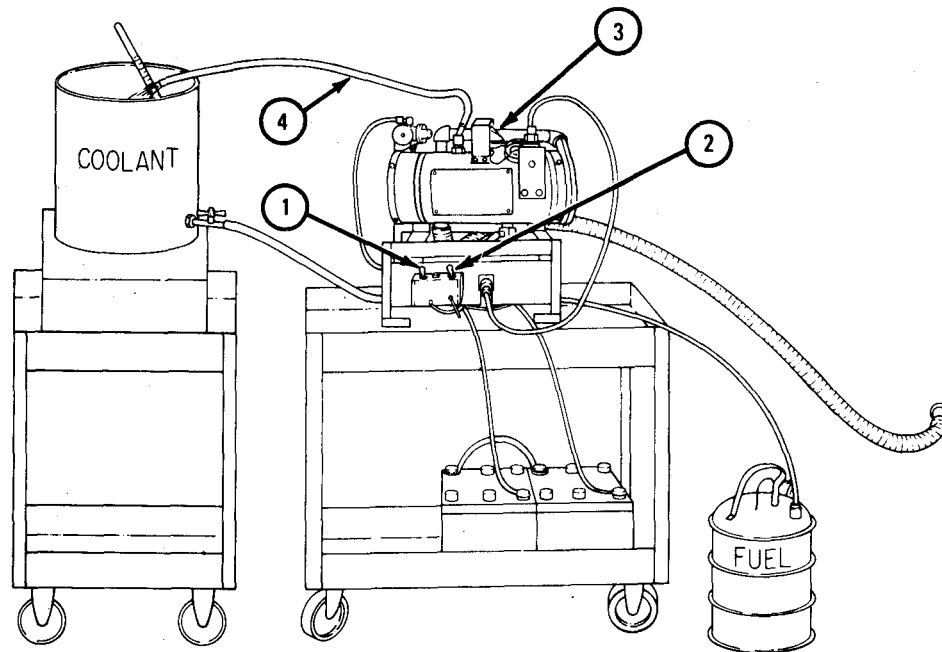

TA 104182

(5) Overheat switch.

FRAME 1

1. Connect jumper wire (1) by terminal screws (2 and 3).
2. Start heater (4) and let it run until pilot light (5) glows.

WARNING

Coolant will be hot. Use caution when working near hot coolant. Severe burns could result.

NOTE

The jumper wire (1) bypasses the restriction thermostat and keeps the heater on HI heat.

3. Measure temperature of coolant at outlet hose (6) by letting coolant run on thermometer.
4. Heater (4) will overheat and burning will stop. Make note of the coolant temperature when burning stops. Temperature should be between 220°F and 250°F.
5. Flip control switch (7) to OFF position. Let the blower motor stop. Take out jumper wire (1).
6. If temperature is not as specified, get new overheat thermostat. Refer to para 21-6c and para 21-6e.

END OF TASK

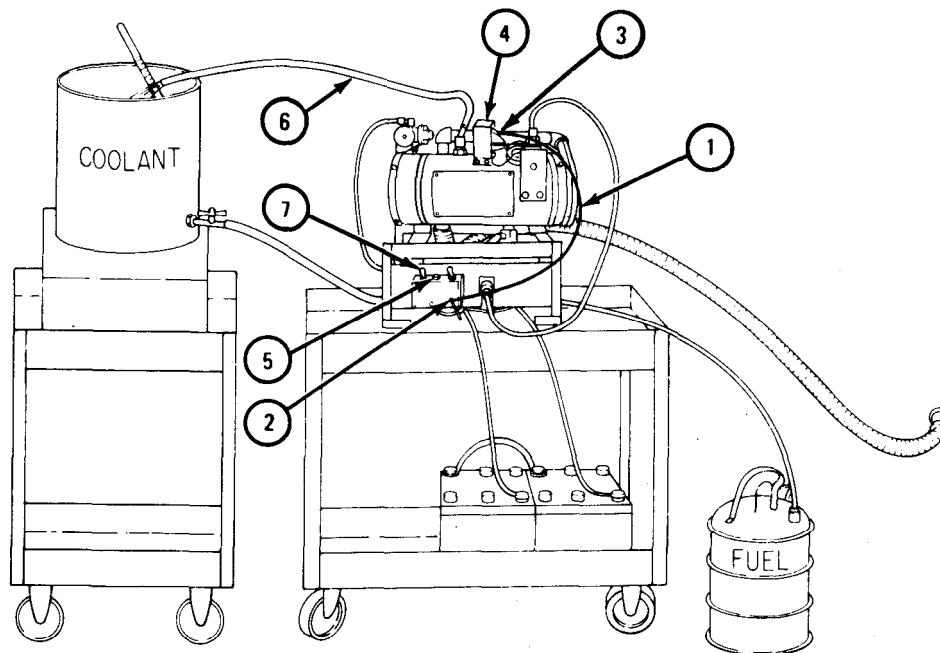

TA 121221

(6) Stopping test.

FRAME 1

1. Put control switch (1) in OFF position, put HI-LO switch (2) in LO position. Take off ground lead (3) from minus (-) battery terminal (4). Take off power supply lead (5) from plus (+) battery terminal (6).
2. Put on and cover plate (7). Refer to para 21-6e, frame 7.

WARNING

Coolant may be hot. Use caution when working near hot coolant. Severe burns could result.

3. Drain coolant from coolant container (8).

GO TO FRAME 2

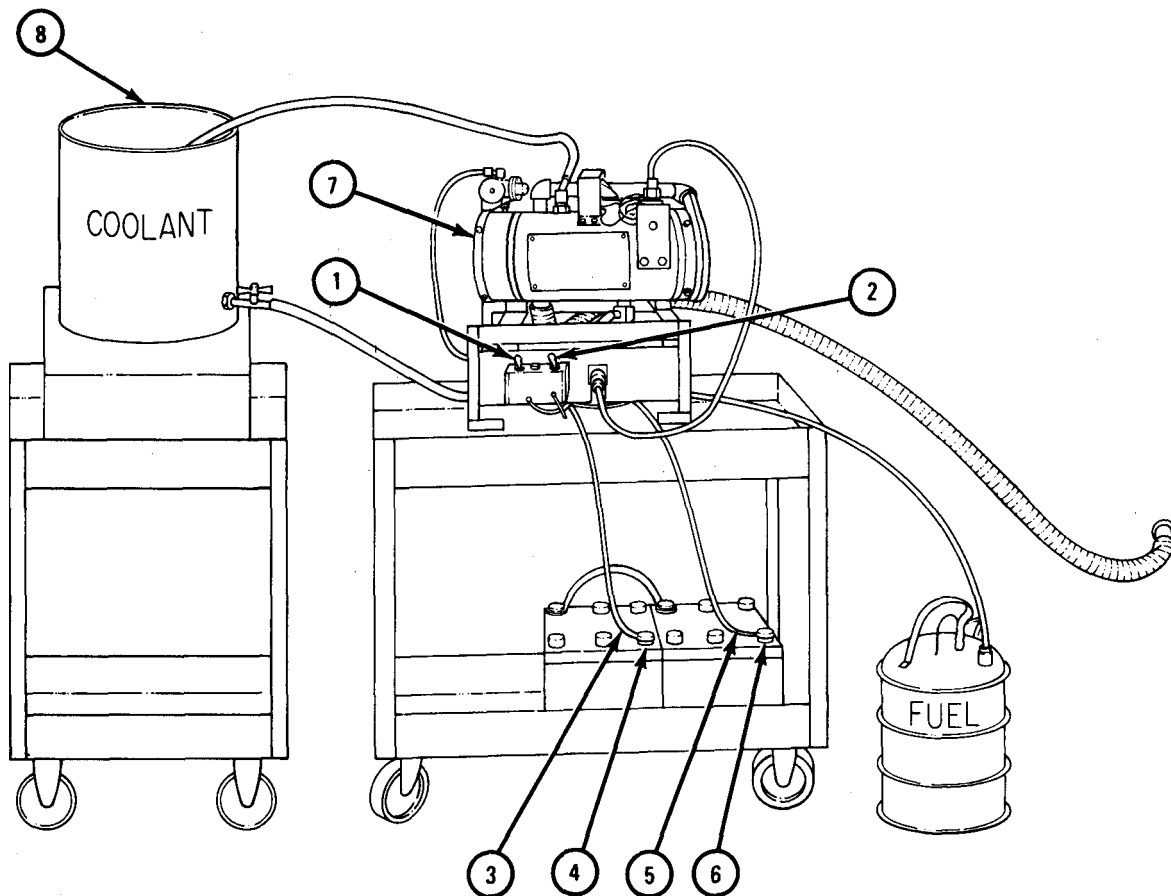

TA 104183

FRAME 2

1. Take off wiring harness (1) from electrical connector (2).
2. Take off fuel supply line (3) from fuel inlet fitting (4). Take off exhaust pipe (5).

WARNING

Coolant may be hot. Use caution when working near hot coolant. Severe burns could result.

3. Take off coolant outlet hose (6) and coolant inlet hose (7).
4. Take off heater (8) from test stand (9).

NOTE

Follow-on Maintenance Action Required:
Replace power plant heater. Refer to para 21-6.

END OF TASK

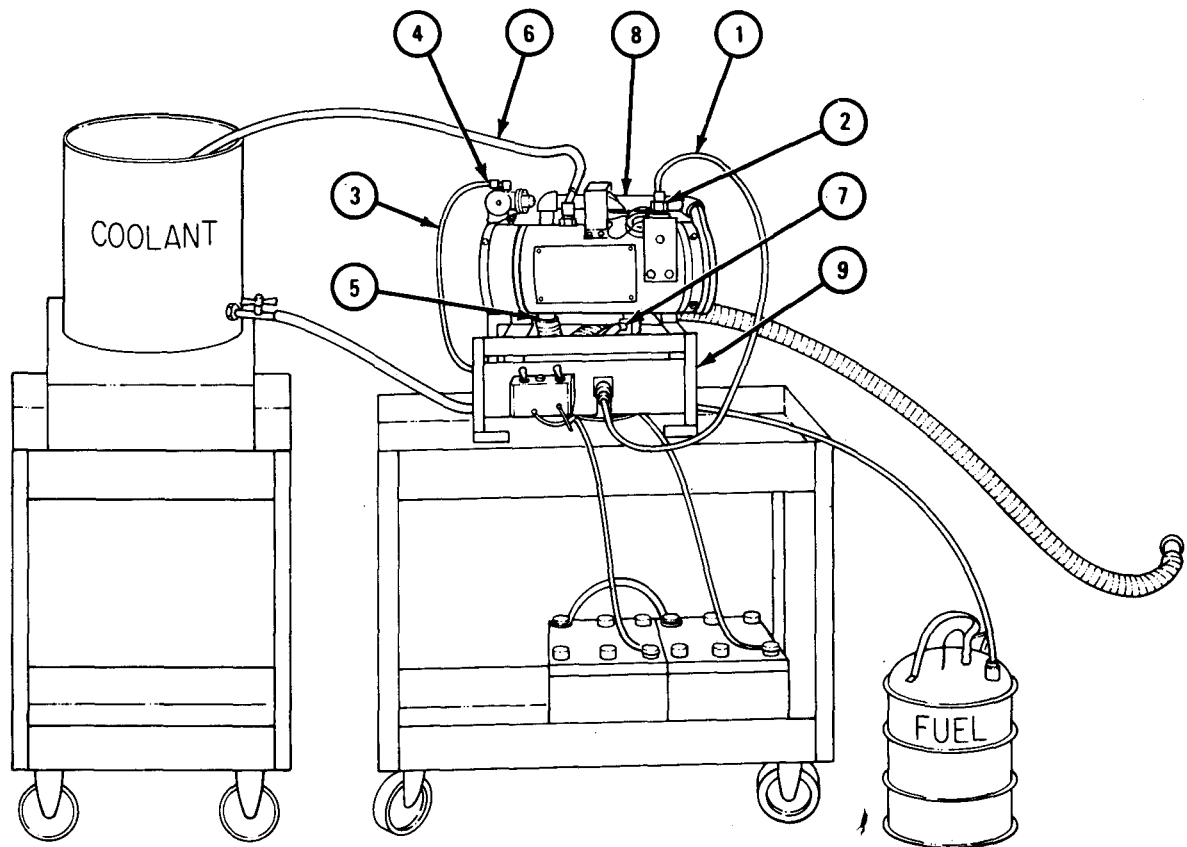

TA 104184

21-6. POWER PLANT HEATER REMOVAL, REPAIR, AND REPLACEMENT.

TOOLS: No special tools required

SUPPLIES: Dry cleaning solvent, typeII (SD-2), Fed. Spec P-D-680
Compressed air, 30 psi max
Clean rags
Burner gasket
Burner preformed packing
Overheat thermostat preformed packing
Fuel control valve gasket
Fuel control valve gasket with screen
Igniter
Igniter gasket

PERSONNEL: One

EQUIPMENT CONDITION: Truck parked, engine off, handbrake set.

a. Preliminary Procedures.

- (1) Disconnect battery ground cable. Refer to TM 9-2320-209-20.
- (2) Take off coolant hoses at heater. Refer to TM 9-2320-209-20.

b. Removal.

FRAME 1

WARNING

Smoking, sparks or open flames are not allowed within 50 feet of work area during this task. Fuel can explode, causing injury to personnel and damage to equipment.

1. Working in battery box, shut off fuel cock (1).
2. Unscrew fitting (2) and pull fuel line (3) from fuel control valve (4).
3. Take out cotter pin (5) and slide off exhaust pipe elbow (6) from heater (7).
4. Unscrew and unplug electrical connector (8) from heater (7).
5. Unscrew and open two heater retainer clamps (9) and take out heater assembly (7).

END OF TASK

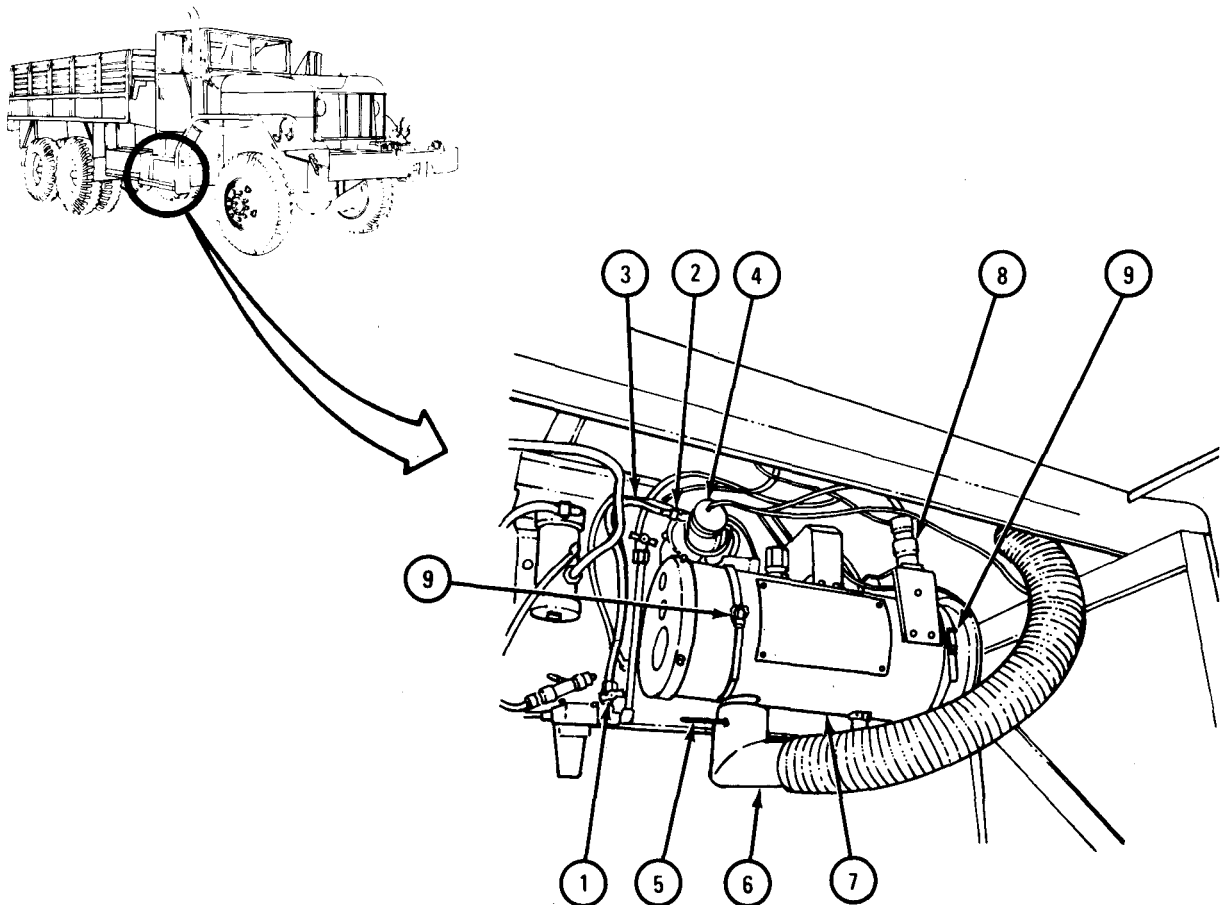

TA 104126

c. Disassembly into Subassemblies.

FRAME 1

1. Unscrew and take out four screws (1), two on each end of guard (2). Take off guard (2).
2. Tag ground electrical lead (3). Unscrew and takeoff nut (4). Takeoff ground electrical lead (3).
3. Take off air inlet tube and elbows (5).

GO TO FRAME 2

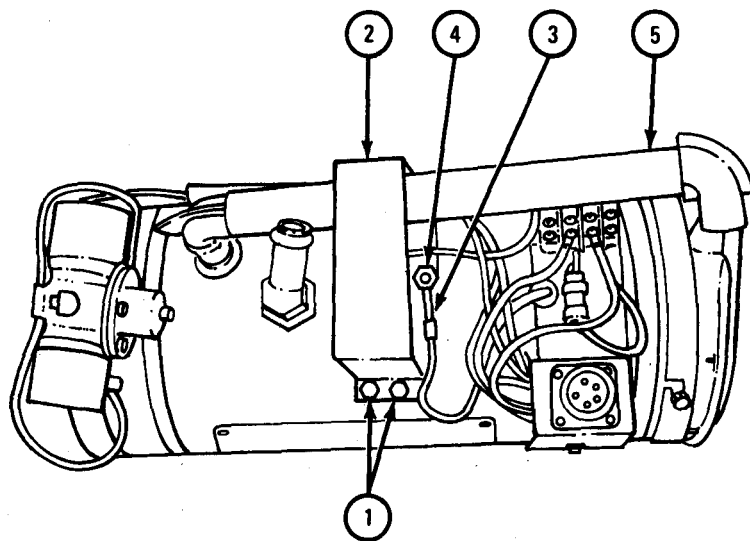

TA 104168

FRAME 2

1. Tag blower motor electrical lead (1) . Unscrew and take out terminal screw (2). Take off blower motor electrical lead (1).
2. Tag terminal screw (2) the same as blower motor electrical lead (1). Screw in terminal screw (2).
3. Scratch a line (3) across blower assembly (4) and housing (5). Loosen four nuts (6) around blower assembly (4).
4. Turn blower assembly (4) so slots (7) clear studs (8). Take off blower assembly (4).

GO TO FRAME 3

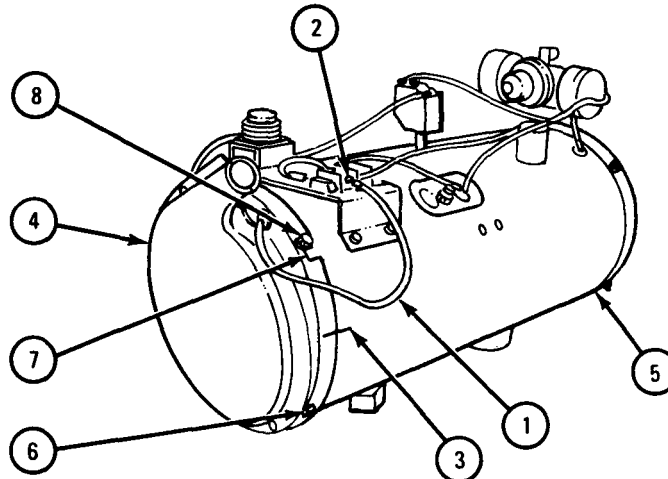

TA 104127

FRAME 3

1. Tag flame detector switch common electrical lead (1). Unscrew and take out terminal screw (2) from flame detector switch (3).
2. Tag terminal screw (2) the same as electrical lead (1). Screw terminal screw (2) with tag into flame detector switch (3).
3. Do steps one and two again for switch middle electrical leads (4 and 5) and switch end electrical leads (6 and 7).
4. Unscrew fitting (8) under flame detector switch (3).

CAUTION

Use care in pulling flame detector switch out. If switch is not pulled straight out, parts in switch will break.

5. Pull flame, detector switch (3) out of housing (9).

GO TO FRAME 4

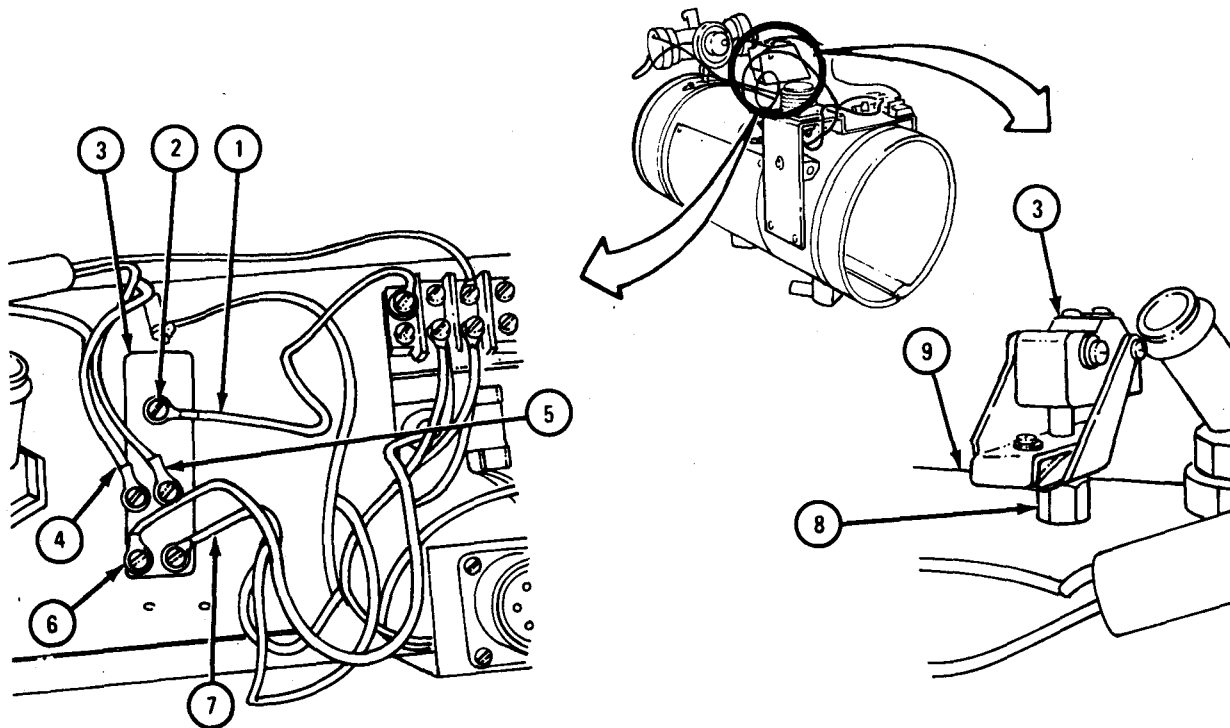

TA 104128

FRAME 4

1. Tag fuel control valve electrical lead (1). Unscrew and take out terminal screw (2). Tag terminal screw (2) the same as electrical lead (1) and screw back into terminal strip (3).
2. Tag each of two overhear thermostat electrical leads (4 and 5) on overhear thermostat (6). Unscrew and take out terminal screw (7).
3. Tag terminal screw (7) the same as electrical leads (4 and 5) and screw terminal screw (7) back into overhear thermostat (6).
4. Do step 2 again for overhear thermostat electrical leads (8 and 9) on terminal screw (10). Take off electrical lead (9).

GO TO FRAME 5

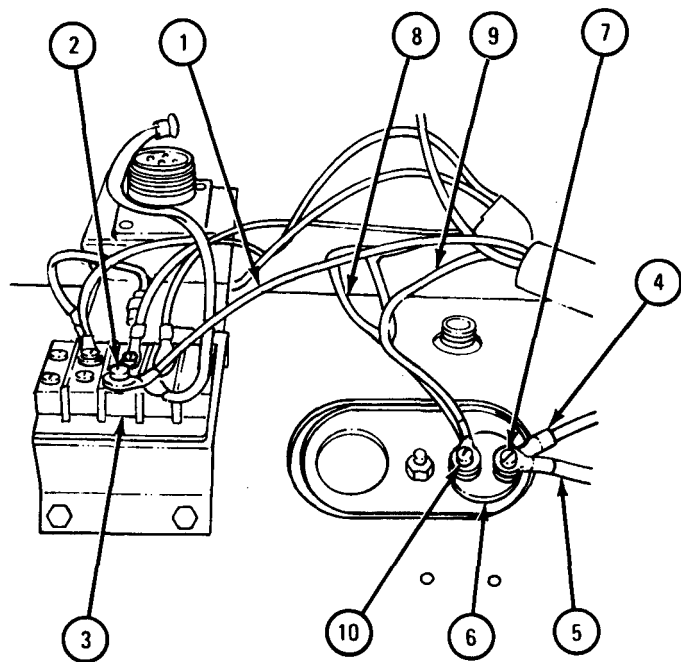

TA 104129

FRAME 5

1. Unscrew fitting (1) under fuel control valve (2).
2. Lift valve (2) from stand pipe (3).
3. Unscrew and take off nut (4), lockwasher (5), cover (6), and overheat thermostat (7).
4. Take off preformed packing (8) from overheat thermostat (7). Throw away preformed packing.

GO TO FRAME 6

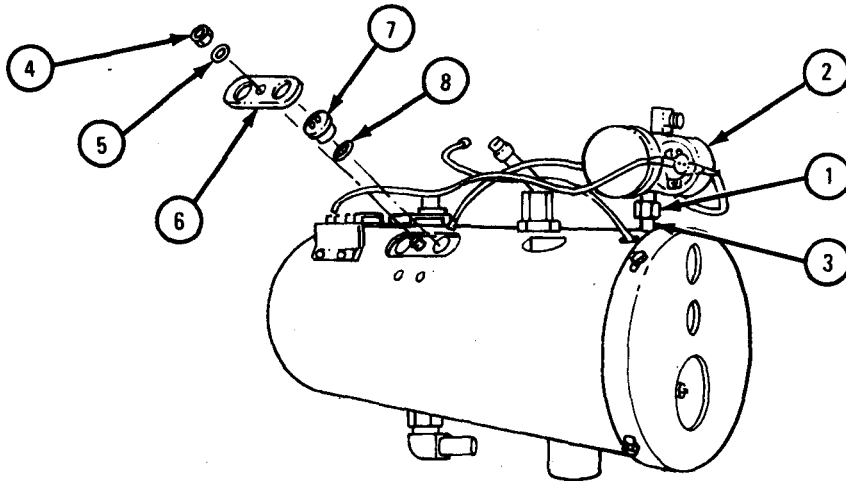

TA 104130

FRAME 6

1. Scratch a line across end plate (1) and housing (2).
2. Loosen four nuts (3). Turn end plate (1) to clear slots (4) and pull end plate (1) off housing (2).

GO TO FRAME 7

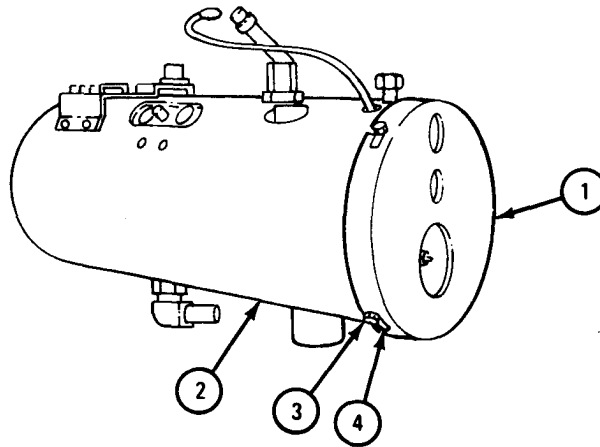

TA 104131

FRAME 7

1. Unscrew and takeout screw, lockwasher, and nut (1). Take off preheat resistor electrical lead (2). Pull lead through hole in housing (3).
2. Tag preheat resistor terminal (4).
3. Unscrew and takeoff nut and lockwasher (5). Takeoff ground strap (6). Unscrew and takeout screw, lockwasher, and nut (7). Takeout ground strap (6) and take off igniter ground wire (8).
4. Unscrew and take off two nuts (9).

GO TO FRAME 8

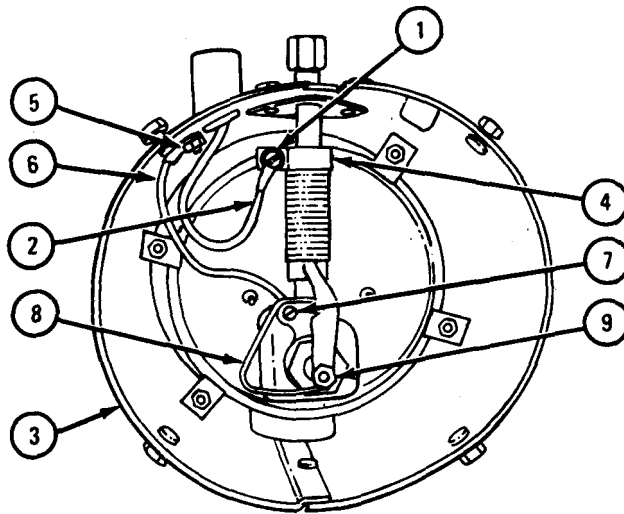

TA 104132

FRAME 8

1. Unscrew and take out two screws (1). Slide off plate (2).
 2. Unscrew fitting (3). Take out stand pipe and preheat resistor (4). Unscrew and take out igniter (5).
 3. Loosen four nuts (6). Turn tie-downs (7) and lift off burner (8).
- GO TO FRAME 9

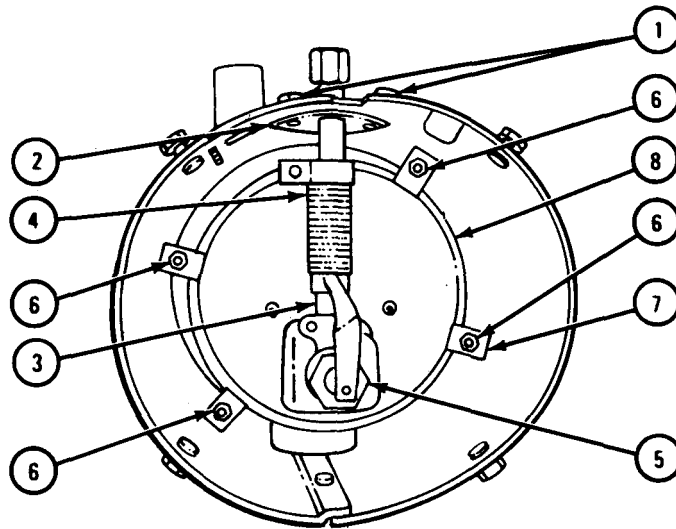

TA 104133

FRAME 9

1. Pull off two thermostat electrical leads (1). Pull leads through hole in housing (2). Tag both leads (1) together.
2. Unscrew and take off two nuts (3) and lockwashers (4). Take off thermostat (5) and two spacers (6).

NOTE

Spacers (6) are a special size. Tag them together so they can be used again when unit is assembled.

GO TO FRAME 10

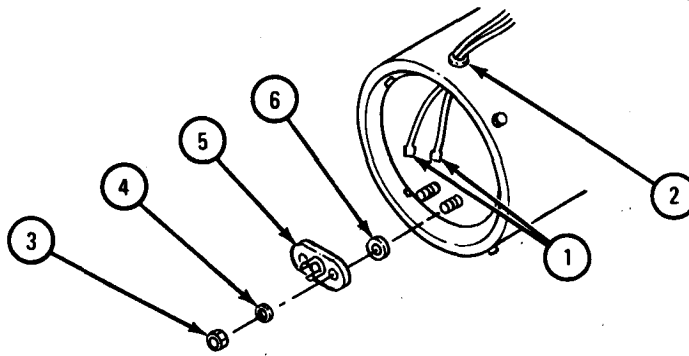

TA 104134

FRAME 10

NOTE

Diode (1) must be put back in the same way it is put in. Diode has an arrow on it; mark the end of the holder (2) that the arrow points to.

1. Take out diode (1) by snapping it out of holder (2).
2. Unscrew and take out four screws (3), two on each end of bracket (4). Take off bracket (4) with electrical leads.

GO TO FRAME 11

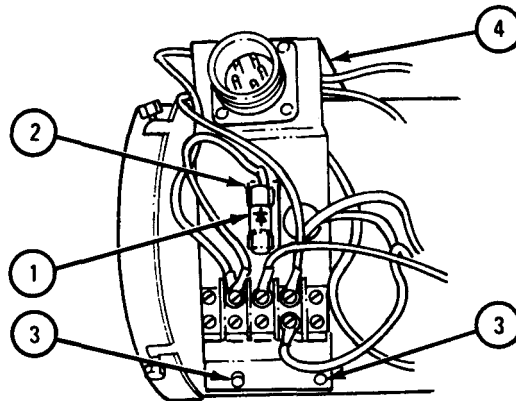

TA 104135

FRAME 11

1. Unscrew and take out three screws (1) along seam of housing (2).

CAUTION

Do not spread housing (2) apart any more than is needed to slide heat exchanger (3) out of housing. Overspreading will make permanent bends in housing.

2. Spread housing (2) apart. Slide heat exchanger (3) out.

END OF TASK

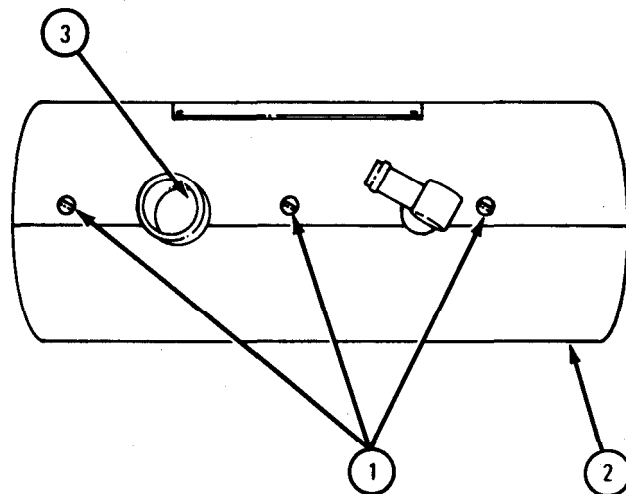

TA 104137

d. Cleaning and Inspection of Subassemblies.**WARNING**

Dry cleaning solvent is flammable. Do not use near an open flame. Keep a fire extinguisher nearby when solvent is used. Use only in well-ventilated places. Failure to do this may result in injury to personnel and damage to equipment.

Eye shields must be worn when using compressed air. Eye injury can occur if eye shields are not used.

CAUTION

Clean subassemblies exactly as told to do, using only tools and cleaning materials told. Damage to equipment will result if this is not done.

NOTE

Parts and subassemblies not referred to in this paragraph should be cleaned and inspected as outlined in Part 1, para 1-3.

(1) Burner and heat exchanger.

FRAME 1

1. Take off gasket (1) from igniter (2). Throw away gasket (1). Make a note whether the amount of carbon on the igniter (2) is a light coating or heavy build-up. Throw igniter away.
2. Take off gasket (3) and preformed packing (4) from burner (5). Throw away gasket and preformed packing. Make a note of amount of carbon on burner (5). Do not take burner apart any further.

CAUTION

Do not damage screen or wick when scraping carbon.
If they are damaged, get new burner assembly (5).

3. Scrape carbon from burner assembly (5) using a sharp tool.
4. Inspect heat exchanger (6) for dents or possible leaks. Get new heat exchanger (6) if it is dented or leaking.

WARNING

Eye shields must be worn when using compressed air. Eye injury can occur if eye shields are not used.

5. Soak heat exchanger (6) in water for a few minutes. Blow out with compressed air.

END OF TASK

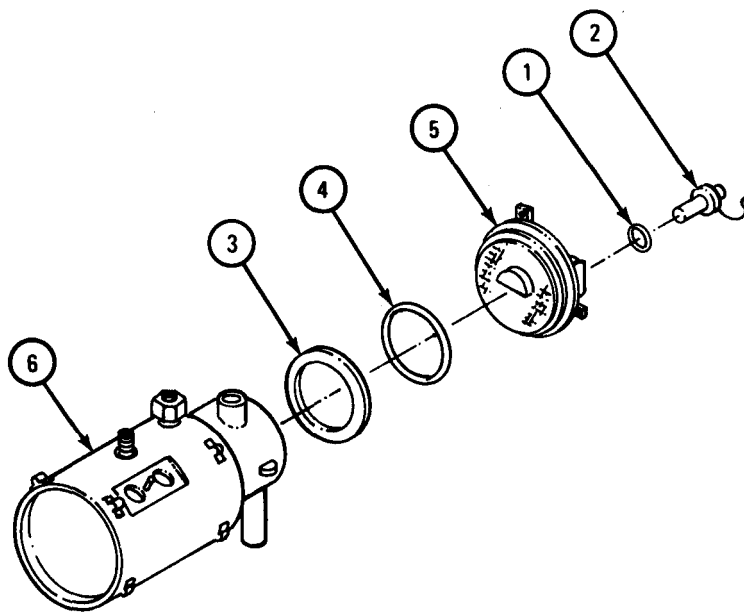

TA 104138

(2) Blower assembly.

FRAME 1

1. Unscrew and take out seven screws (1) and speed nuts (2). Lift off blower cover (3).
2. Loosen setscrew (4) in hub of blower wheel (5). Lift off blower wheel (5).
3. Carefully pull blower motor electrical lead (6) through grommeted hole in blower plate (7).
4. Unscrew and take out three screws (8). Lift off blower plate (7). Take off three spacers (9) from blower motor (10).

CAUTION

Do not dip blower motor in solvent. Bearings will be damaged. Do not take blower motor apart. It cannot be repaired.

5. Wipe blower motor (10) clean with cloth. Inspect blower motor for broken housing, bent shaft or signs of overheating. Inspect electrical lead (6) for broken or worn insulation.
6. Get new motor if any of the conditions in step 5 are found. Get new motor if motor was known not to be working or heavy carbon was found on igniter or burner.

WARNING

Dry cleaning solvent is flammable. Do not use near an open flame. Keep a fire extinguisher nearby when solvent is used. Use only in well-ventilated places. Failure to do this may result in injury to personnel and damage to equipment.

7. Clean the rest of blower parts in dry cleaning solvent and wipe dry.

GO TO FRAME 2

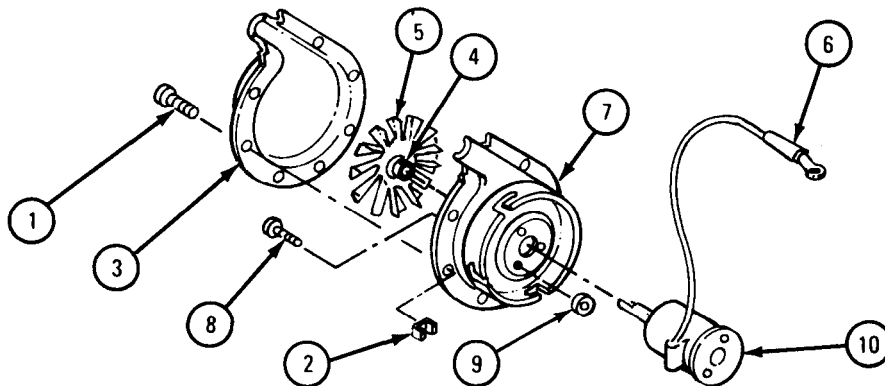

TA 104139

FRAME 2

1. Put three spacers (1) on bosses on blower motor (2).
 2. Put blower plate (3) on spacers (1). Be sure grommetted hole (4) is near blower motor electrical lead (5).
 3. Screw in and tighten three screws with starwashers (6).
 4. Put on blower wheel (7) so top of hub (8) is flush with motor shaft (9). Be sure setscrew (10) is opposite flat on motor shaft (9). Tighten setscrew (10).
 5. Put electrical lead (5) through grommetted hole (4).
- GO TO FRAME 3

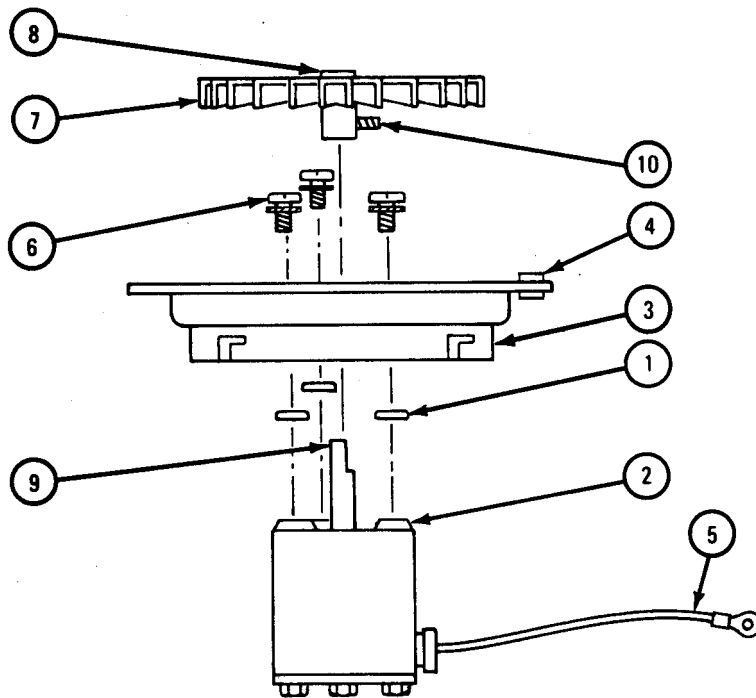

TA 104140

FRAME 3

1. Put blower cover (1) in place on blower assembly (2). Using a stiff wire, turn blower wheel (3) through the outlet opening (4). Be sure blower wheel (3) spins freely.
2. If blower wheel (3) does not turn freely, take off blower cover (1). Change position of blower wheel as in frame 2, step 4. Do step 1 again.
3. Put on seven screws (5) and speed nuts (6). Tighten screws (5).

END OF TASK

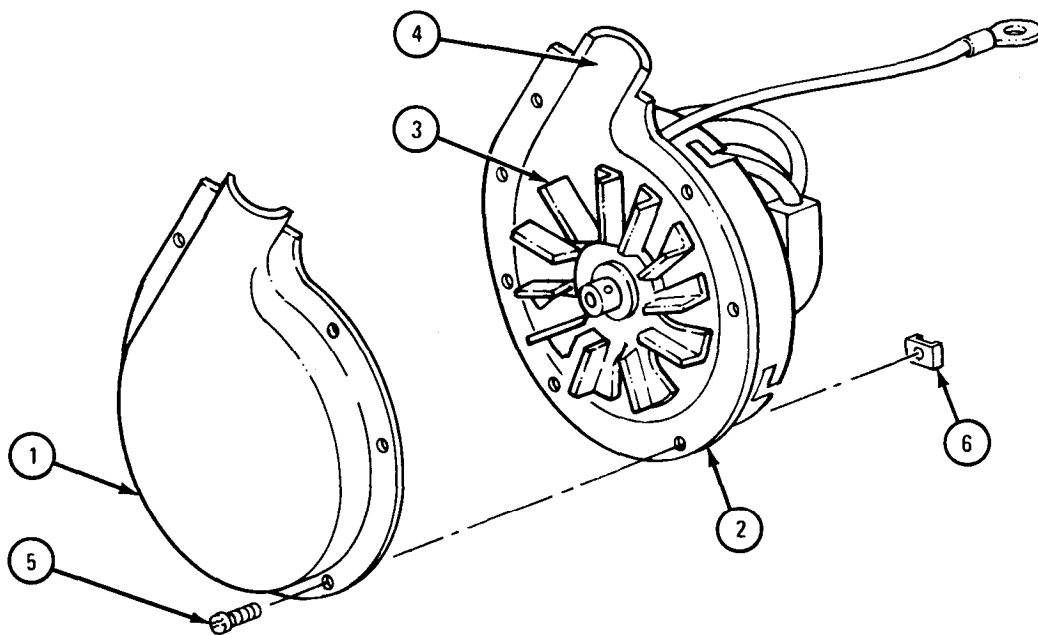

TA 104141

(3) Overheat thermostat, restriction thermostat, diode and electrical leads.

FRAME 1

CAUTION

Rough handling of thermostats can cause them not to work right.

1. Clean overheat thermostat (1), restriction thermostat (2), and diode (3) with clean cloth.
2. Inspect overheat thermostat (1), restriction thermostat (2), and diode (3) for corrosion. If they are corroded, get new parts.
3. If overheat thermostat (1) or restriction thermostat (2) are known not to be working right, like the heater overheating, get new ones.

NOTE

Thermostats and diode are not able to be fixed. If they do not pass tests, get new ones.

4. Place leads of ohmmeter on each terminal (4 and 5) of overheat thermostat (1). Circuit should be closed.
5. Place one lead of ohmmeter on overheat thermostat case (1). Place other lead on terminal (4 or 5). Circuit should be open.
6. Get new overheat thermostat (1) if it does not pass tests in steps 4 and 5.
7. Do steps 4, 5 and 6 again for terminals (6 and 7) of restriction thermostat (2).
8. Place leads of ohmmeter on ends of diode (3). Note if circuit is open or closed. Switch leads on ends of diode. Note if circuit is open or closed.
9. Circuit must be closed in one test and open in the other. If circuit is open or closed in both directions, diode must be replaced.
10. Inspect electrical leads (8 and 9) for broken or worn insulation and broken terminals. Inspect ground strap (10) for broken terminals.
11. Check continuity through electrical leads (8 and 9) and ground strap using an ohmmeter. Place an ohmmeter lead on each terminal of each lead. Get new electrical leads (8 and 9) or ground strap (10) if circuit is open.

END OF TASK

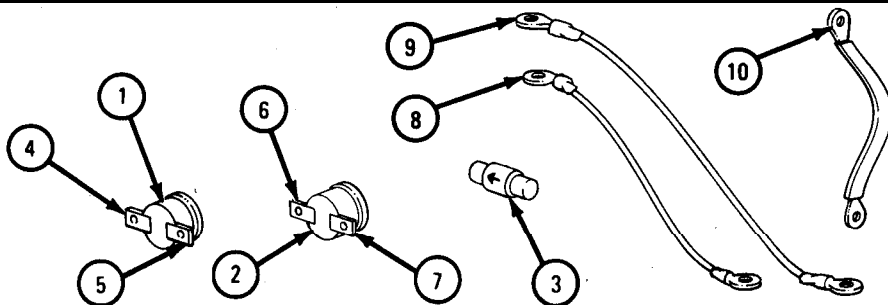

TA 104142

(4) Flame detector switch.

FRAME 1

WARNING

Dry cleaning solvent is flammable. Do not use near an open flame. Keep a fire extinguisher nearby when solvent is used. Use only in well-ventilated places. Failure to do this may result in injury to personnel and damage to equipment.

1. Wipe flame detector switch (1) with cloth dipped in dry cleaning solvent. Do not dip switch into solvent because it may be damaged. Wipe flame detector switch dry.
2. Unscrew and take out adjusting screw and washer (2). Loosen two screws (3).
3. Flip up microswitch (4) and take off bar spring (5).

CAUTION

Do not let quartz rod (6) fall out of flame detector switch. Do not drop quartz rod. Doing so may break or chip quartz rod.

4. Turn flame detector switch (1) over and let quartz rod (6) slide out of tube (7). Tap bottom of tube (7) to get out any broken pieces of quartz rod.

GO TO FRAME 2

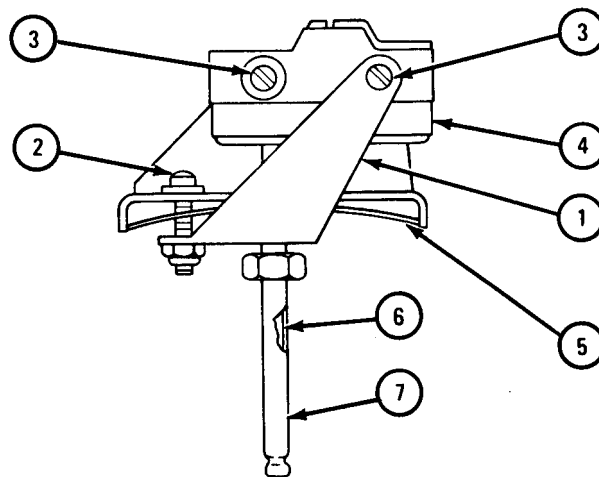

TA 104143

FRAME 2

1. Clean tube (1) of flame detector switch (2) with wire brush. Check tube for straightness. Get new flame detector switch (2) if tube (1) is not straight.
2. Clean bow spring (3) with wire brush. Bow spring (3) should be straight. Get new flame detector switch (2) if bow spring is bent.
3. Check to see if microswitch (4) clicks by pressing in on shaft (5). Microswitch (4) should also click when shaft (5) is let out. Get new flame detector switch (2) if microswitch (4) does not click.
4. Check that quartz rod (6) is not broken or chipped. Get new quartz rod (6) if it is broken or chipped.

GO TO FRAME 3

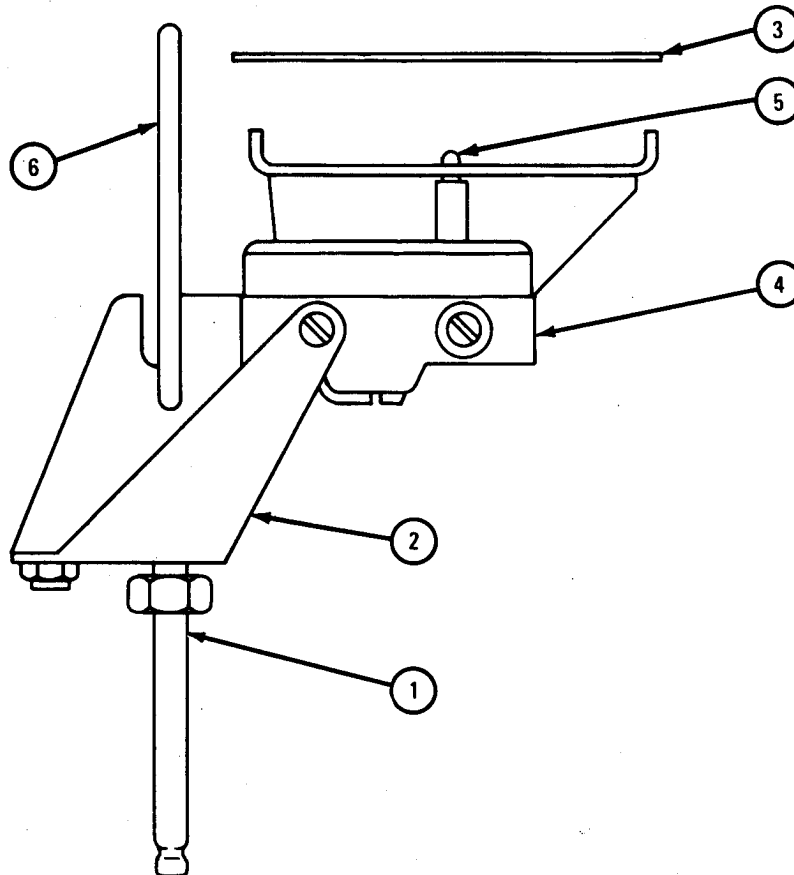

TA 104144

FRAME 3

1. Slide quartz rod (1) into tube (2) of flame detector switch (3). Place bow spring (4) on microswitch frame (5). Flip microswitch (6) down into place.
2. Screw in adjusting screw and washer (7) and push up on bow spring (4) while tightening adjusting screw (7).
3. Tighten screws (8) just tight enough so microswitch (6) is held in place.
4. Slowly unscrew adjusting screw (7) until microswitch (6) clicks. Slowly screw in adjusting screw (7) until microswitch (6) clicks. Screw in adjusting screw (7) exactly three-fourths of a turn more.
5. Tighten screws (8).

END OF TASK

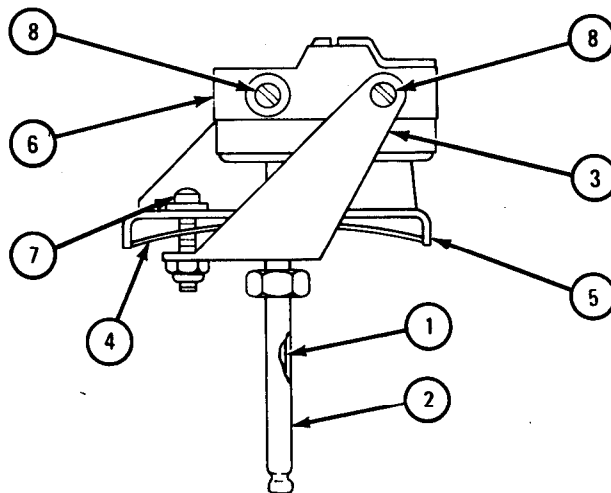

TA 104145

(5) Fuel control valve.

FRAME 1

WARNING

Dry cleaning solvent is flammable. Do not use near an open flame. Keep a fire extinguisher nearby when solvent is used. Use only in well-ventilated places. Failure to do this may result in injury to personnel and damage to equipment.

CAUTION

Do not dip fuel control valve (1) in dry cleaning solvent. Electrical parts may be damaged by doing so.

1. Wipe fuel control valve (1) clean with a clean cloth dipped in dry cleaning solvent. Wipe fuel control valve (1) dry.
2. Inspect fuel control valve (1) for cracked or broken parts. Go to step 6 if cracks or breaks are found.
3. Inspect electrical leads (2, 3, 4, 5, 6, and 7) for broken or frayed insulation or damaged connectors on the ends. Go to step 6 if any electrical leads or connectors are bad.
4. Using an ohmmeter, check continuity through heater. Place one ohmmeter lead on terminal (8) and the other ohmmeter lead on terminal (9). Circuit should be closed. If circuit is open, go to step 6.
5. If fuel control valve (1) passes tests, to go frame 2. If you must get a new fuel control valve, do step 6.

NOTE

Electrical leads (2 and 7) must be used on new fuel control valve.

6. Unscrew and take off nut (10). Take off electrical lead (2) and slide off electrical lead (7). Get a new fuel control valve.

GO TO FRAME 2

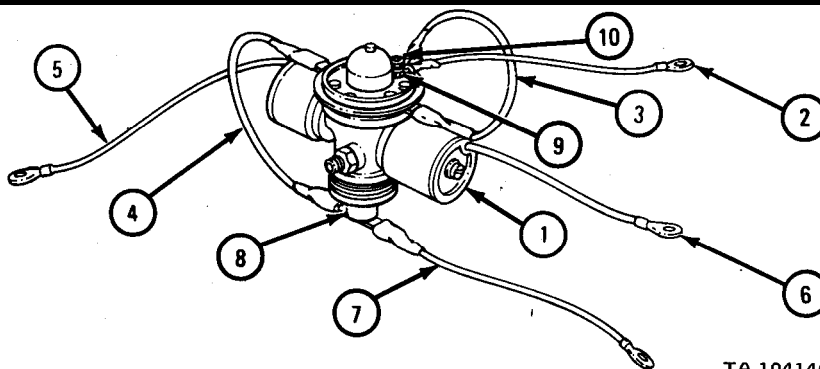

FRAME 2

1. Fuel control valve (1) should be tested for leaks and proper fuel flow. Refer to para 21-9e, frames 7 through 12.

IF FUEL CONTROL VALVE (1) PASSES TESTS, GO TO FRAME 3.

IF FUEL CONTROL VALVE (1) FAILS TESTS, GET A NEW FUEL CONTROL VALVE (1). GO TO FRAME 6

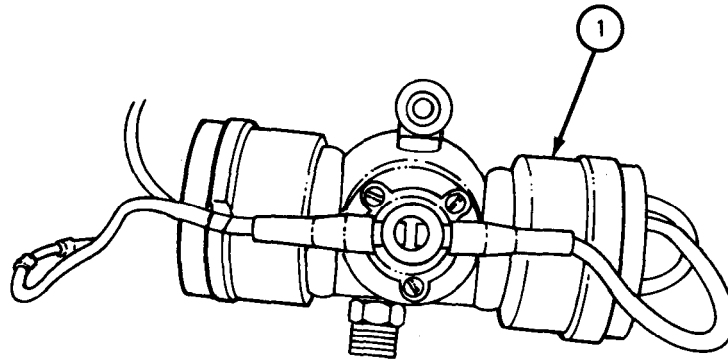

TA 104176

CAUTION

Do not use anything but a warm hand to warm up thermostat (1). Flame or high heat will cause thermostat to lose calibration.

1. Hold warm hand on thermostat (1) for five minutes to warm it to 75°F or higher.
2. Using an ohmmeter, check continuity through thermostat (1). Place one ohmmeter lead on terminal (2) and other ohmmeter lead on terminal (3).
3. If circuit is open, go to step 4. If circuit is closed, go to frame 5.

CAUTION

Do not place thermostat (1) or fuel control valve (4) in any type of liquid to cool it. Thermostat and fuel control valve are not sealed from liquids.

4. Place fuel control valve (4) in refrigerator set to 20°F for 30 minutes.
5. Do step 2 again.

IF CIRCUIT IS OPEN, GO TO FRAME 5.
IF CIRCUIT IS CLOSED, GO TO FRAME 4

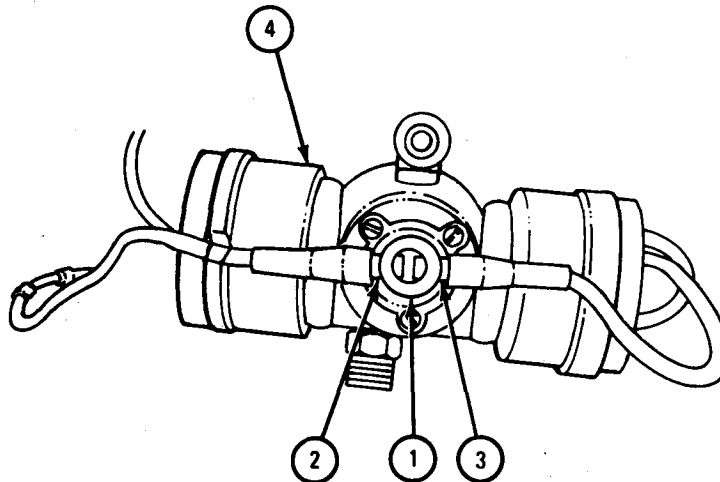

TA 104148

FRAME 4

1. Unscrew and take out fuel inlet fitting (1).
2. Inspect, but do not take out, screen (2) in fuel inlet (3).
3. If screen (2) is dirty or clogged, get new fuel control valve (4). Go to frame 6.
4. If screen (2) is not dirty or clogged, screw in and tighten fuel inlet fitting (1), Be sure opening of fuel inlet fitting points toward thermostat (5).

GO TO FRAME 5

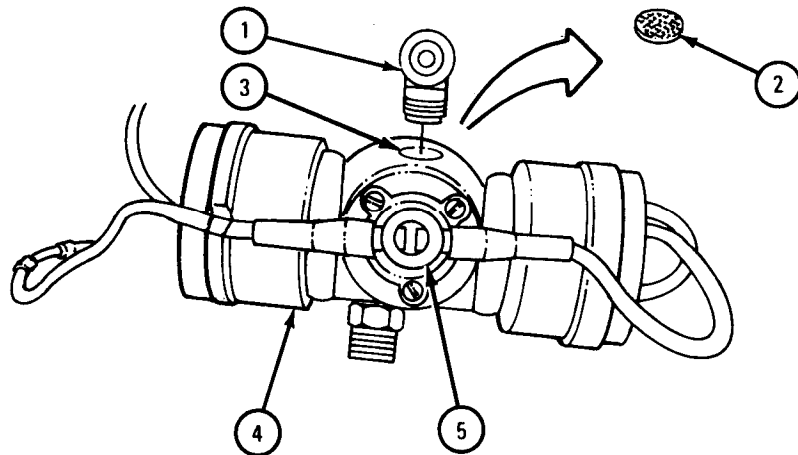

TA 104149

FRAME 5

CAUTION

Use clean tools, have clean hands, and work on clean surface when taking apart fuel control valve. Even the smallest piece of dirt will cause the valve not to work right.

1. Pull off electrical leads (1 and 2) from thermostat (3).
2. Unscrew and take out three screws (4). Take off clamp (5) and thermostat (3).
3. Take off cover plate (6), gasket (7), orifice plate (8), and gasket (9). Throw away gaskets (7 and 9).

WARNING

Eye shields must be worn when using compressed air. Eye injury can occur if eye shields are not used.

CAUTION

Do not force anything through the orifice plate (8) openings. The slightest change in the calibrated openings in the plate may cause serious overheating problems.

4. Clean orifice plate (8) and cover plate (6) with compressed air. Inspect orifice plate (8) with a magnifier. Check for cracks or burrs. Get new orifice plate if cracks or burrs are found.

GO TO FRAME 6

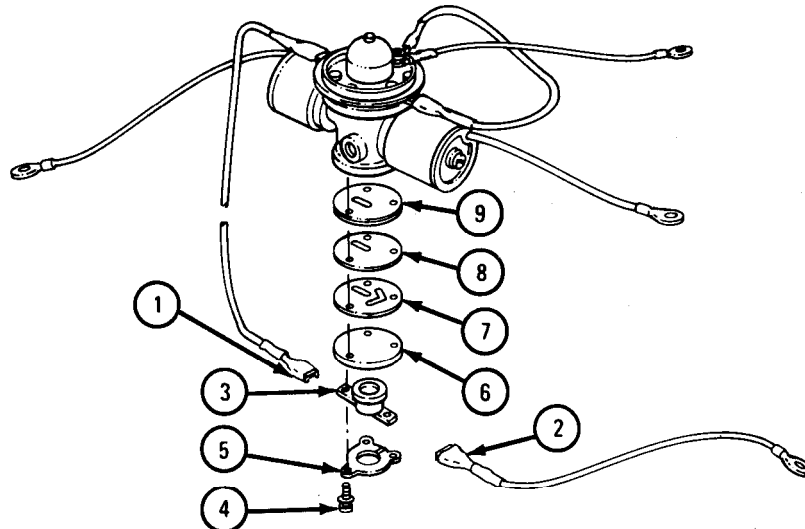

TA 104150

FRAME 6

1. Heat thermostat (1) to 75°F.
2. Using ohmmeter, check continuity through thermostat (1). Put one ohmmeter lead on terminal (2) and the other ohmmeter lead on terminal (3).
3. If circuit is closed, get new thermostat (1) and go to frame 6. If circuit is open, do step 4.

CAUTION

Do not put thermostat (1) in any type of liquid to cool it.
Thermostat may be damaged.

4. Cool thermostat (1) to 20°F.
5. Do step 2 again.
6. If circuit is open, get new thermostat (1).

GO TO FRAME 7

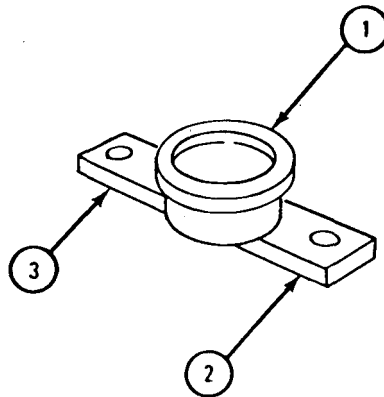

TA 121074

FRAME 7

NOTE

Put gasket (1), orifice plate (2), and gasket (3) on cover plate (4) exactly as shown. Put orifice plate and gasket assembly (5) on fuel control valve (6) exactly as shown.

1. Put new gasket (1), orifice plate (2), and new gasket (3) on cover plate (4).
2. Put orifice plate and gasket assembly (5) on fuel control valve body (6).
3. Put thermostat (7) and clamp (8) on orifice plate and gasket assembly (5).
4. Screw in three screws (9) finger tight. Tighten three screws evenly, tightening each one a little at a time.
5. Slide two electrical leads (10) on terminals of thermostat (7).
6. Do frame 2 again if fuel control valve did not pass fuel flow test. If fuel control valve still does not pass fuel flow test, get new fuel control valve.

END OF TASK

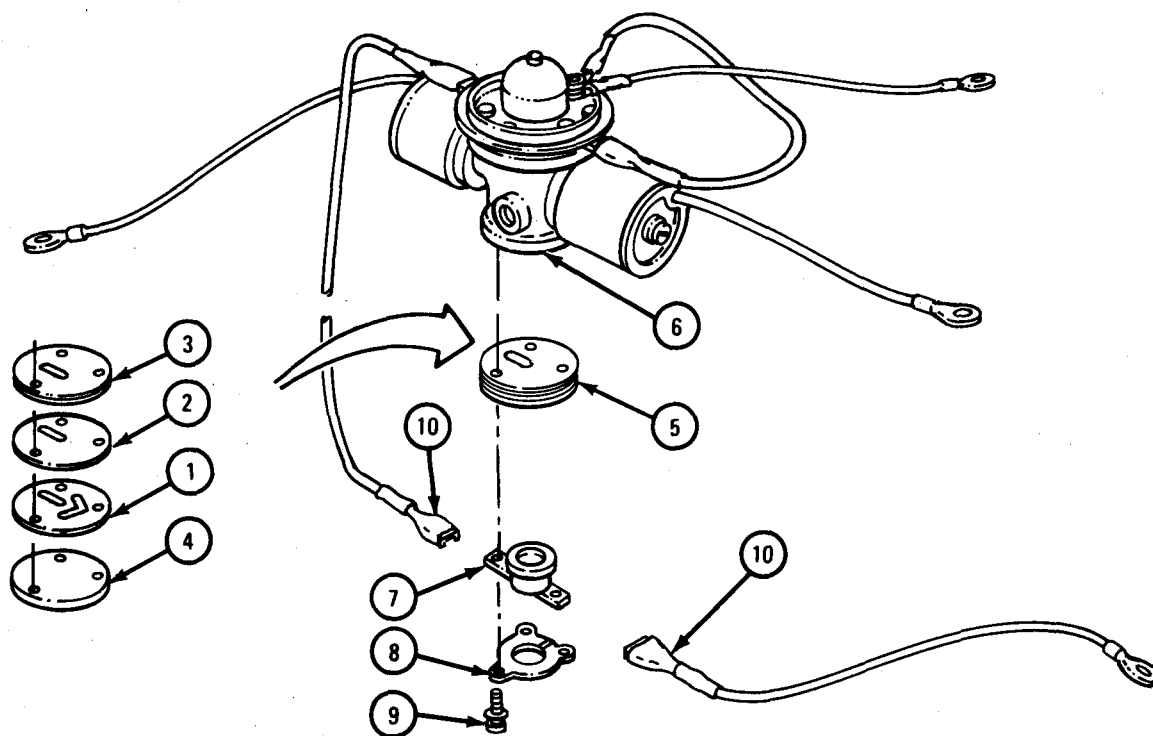

TA 104151

(6) Motor resistor, electrical leads, and connector.

FRAME 1

WARNING

Dry cleaning solvent is flammable. Do not use near an open flame. Keep a fire extinguisher nearby when solvent is used. Use only in well-ventilated places. Failure to do this may result in injury to personnel and damage to equipment.

1. Wipe bracket (1) with electrical leads (2,3, 4, and 5) with cloth dipped in dry cleaning solvent. Wipe bracket and electrical leads dry.
2. Inspect five electrical leads (2) for damaged insulation and connectors. Go to frame 2 if leads are bad.
3. Check continuity through electrical leads (2) by using an ohmmeter. Place one ohmmeter lead on end of electrical lead, the other ohmmeter lead on end of electrical lead's pin. Go to frame 2 if an open circuit is found.
4. Inspect electrical leads (3, 4, and 5) for damaged insulation and connectors. Get new leads if leads are bad.
5. Check continuity through electrical leads (3, 4, and 5) by placing ohmmeter leads on each end of electrical lead. Get new lead if circuit is open.
6. Inspect terminal strip (7) and diode holder (8) for cracks and damaged threads. Go to frame 2 if any are found.
7. Check motor resistor by placing ohmmeter leads on outer terminals (9 and 10) of terminal strip (7). Go to frame 2 if circuit is open.

END OF TASK

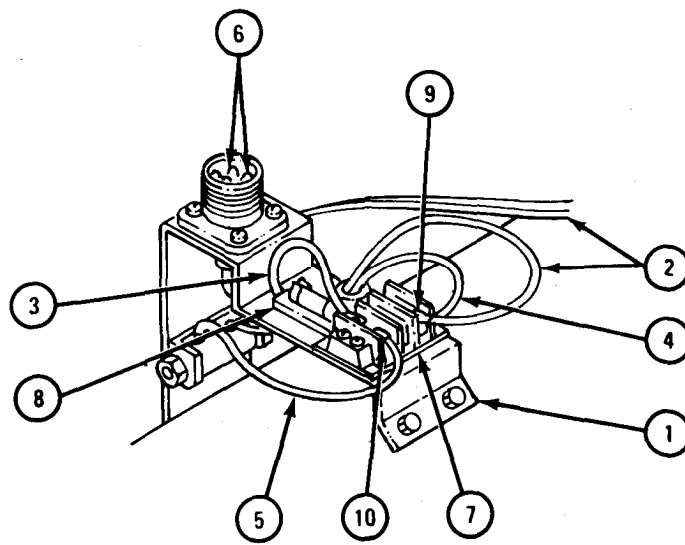

TA 104152

FRAME 2

NOTE

Do only those steps in this frame needed to make repairs as found in frame 1. Parts not called out are for reference only.

1. Unscrew and take out four screws (1). Take off electrical connector (2) with electrical leads.
2. Unscrew and take out four screws (3). Take off terminal strip (4).
3. Unscrew and take out two screws (5). Take off diode holder (6).
4. Unscrew and take off nut (7). Pull out screw (8) and pull out resistor (9).

GO TO FRAME 3

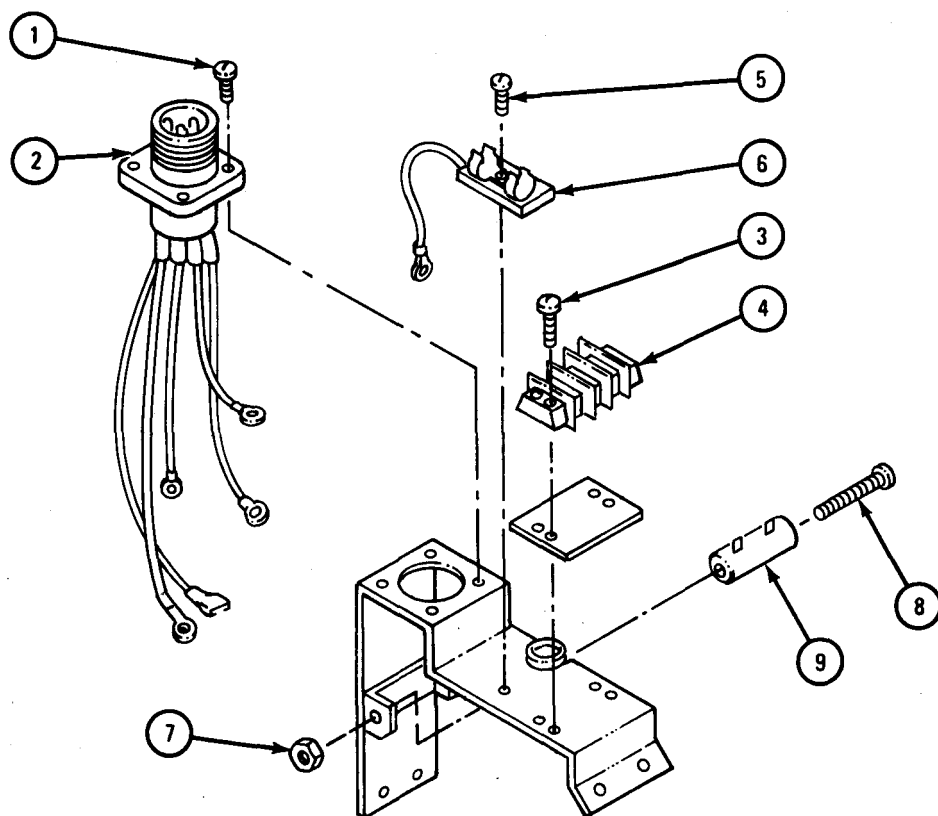

TA 104153

FRAME 3

NOTE

Do only those steps needed to put back new parts taken off in frame 2. Parts not called out are for reference only.

1. Put electrical connector (1) with electrical leads in place on bracket (2). Screw in and tighten four screws (3).
2. Put terminal strip (4) in place on bracket (2). Screw in and tighten four screws (5).
3. Put diode holder (6) in place on bracket (2). Screw in and tighten two screws (7).
4. Put motor resistor (8) in place on bracket (2). Put in screw (9). Screw on and tighten nut (10).

END OF TASK

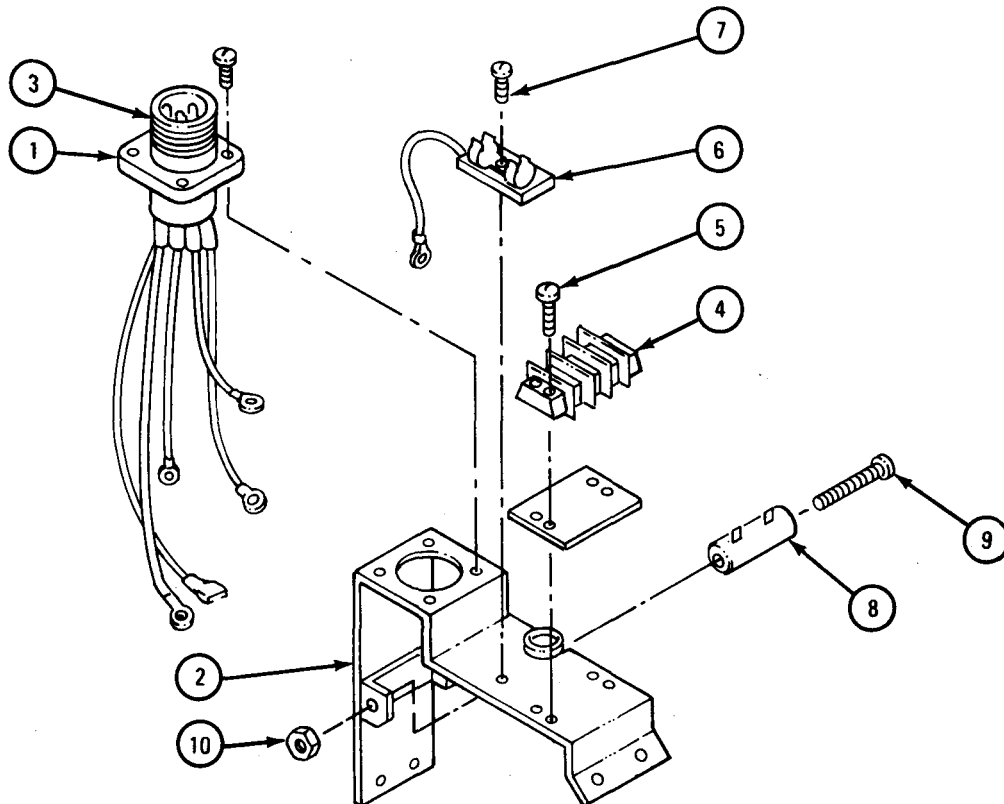

TA 104154

(7) Fuel standpipe and preheat resistor.

FRAME 1

WARNING

Dry cleaning solvent is flammable. Do not use near an open flame. Keep a fire extinguisher nearby when solvent is used. Use only in well-ventilated places. Failure to do this may result in injury to personnel and damage to equipment.

1. Clean fuel standpipe (1) with cloth dipped in dry cleaning solvent. Wipe fuel standpipe dry.
2. Check continuity through preheat resistor (2) with an ohmmeter. Place ohmmeter leads on terminals (3 and 4). If circuit is open, get new preheat resistor (2).
3. Check compression fitting (5) and union nut (6) for damage.

IF ANY PARTS ARE DAMAGED, GO TO FRAME 2.
END OF TASK

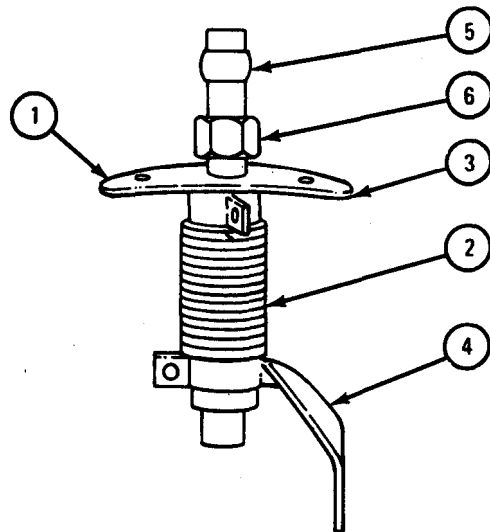

TA 104155

FRAME 2

CAUTION

Use care in grinding or cutting compression fitting (1) from fuel standpipe (2). Damage to other parts of fuel standpipe could result.

1. Cut or grind compression fitting (1) from standpipe (2).
2. Slide off union nut (3), flange (4), and preheat resistor (5) from standpipe (2).

GO TO FRAME 3

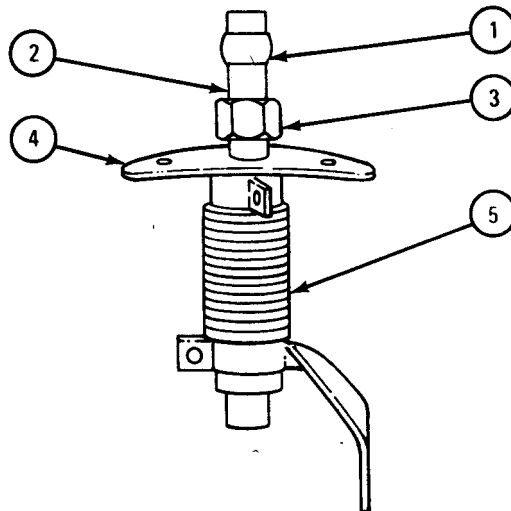

TA 104156

FRAME 3

1. Slide preheat resistor (1), flange (2), and union nut (3) on standpipe (4).
2. Slide new compression fitting (5) on standpipe (4).

END OF TASK

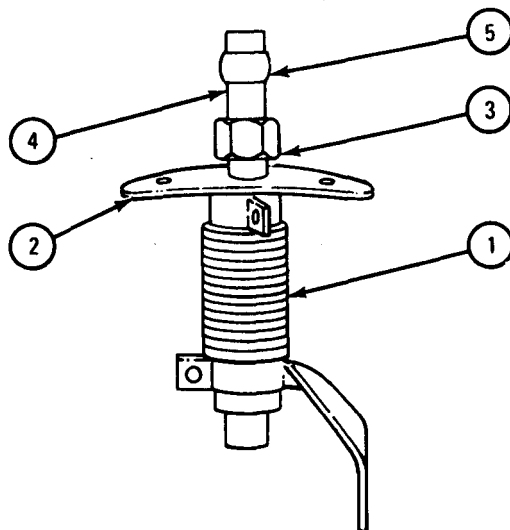

TA 104157

e. Assembly.

FRAME 1

CAUTION

Do not spread housing (1) apart any more than is needed to slide heat exchanger (2) into housing. Overspreading will make permanent bends in housing.

1. Spread housing (1) apart. Slide in heat exchanger (2).
2. Screw in and tighten three screws (3) along seam of housing (1).

GO TO FRAME 2

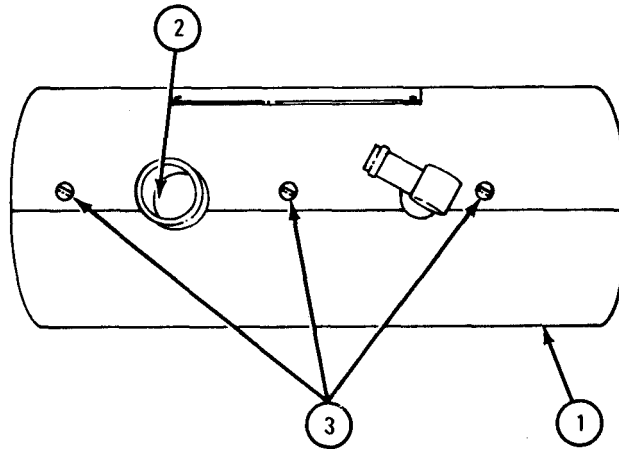

TA 104158

FRAME 2

NOTE

Match tags on electrical leads with tags on terminals when connecting electrical leads to terminals.

1. Put bracket (1) with electrical leads on housing (2). Screw in and tighten four screws (3), two on each end of bracket (1).
2. Put two restriction thermostat electrical leads (4) through grommets hole (5).

NOTE

Diode (6) must be put back in exactly as it was taken out. Diode has an arrow on it; the arrow points to the end of the holder (7) that has the mark.

3. Snap diode (6) into holder (7).

GO TO FRAME 3

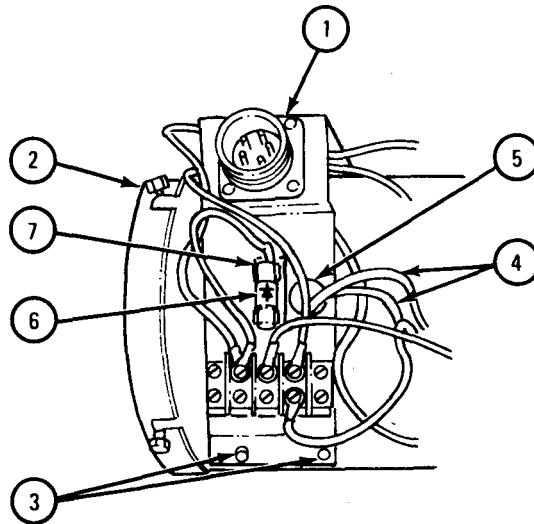

TA 104159

FRAME 3

1. Put one spacer (1) on each stud (2). Put on restriction thermostat (3) and two lockwashers (4). Screw on and tighten two nuts (5).
 2. Slide two electrical leads (6) on terminals of restriction thermostat (3).
- GO TO FRAME 4

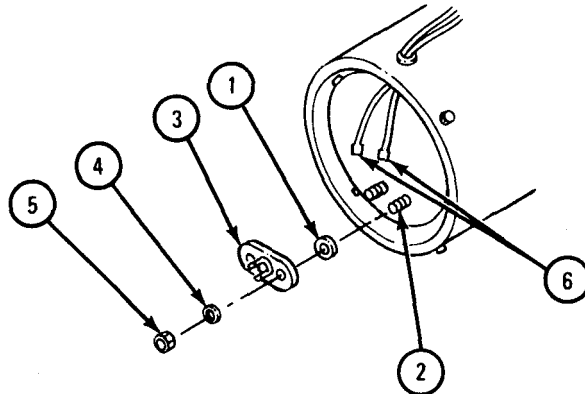

TA 104160

FRAME 4

1. Put new preformed packing (1) and gasket (2) on burner (3).
 2. Put burner assembly (3) on heat exchanger (4) as shown. Turn tie-downs (5) and tighten nuts (6).
 3. Screw in and tighten new igniter (7).
- GO TO FRAME 5

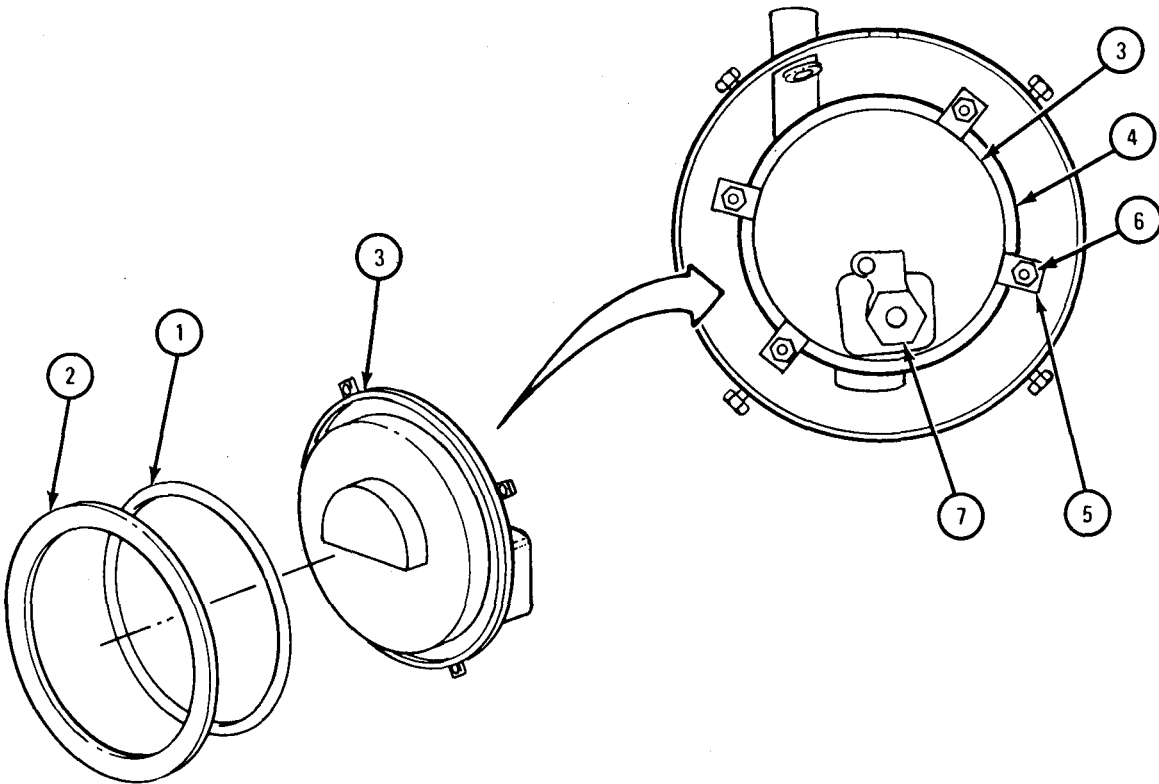

TA 104161

FRAME 5

1. Put fuel standpipe assembly (1) on burner (2). Screw on and tighten fitting (3).
2. Put strap (4) on igniter (5). Screw on and tighten two nuts (6).
3. Slide plate (7) around fuel standpipe (1), Screw in and tighten two screws (8).
4. Put preheat resistor electrical lead (9) through grommets hole (10).

GO TO FRAME 6

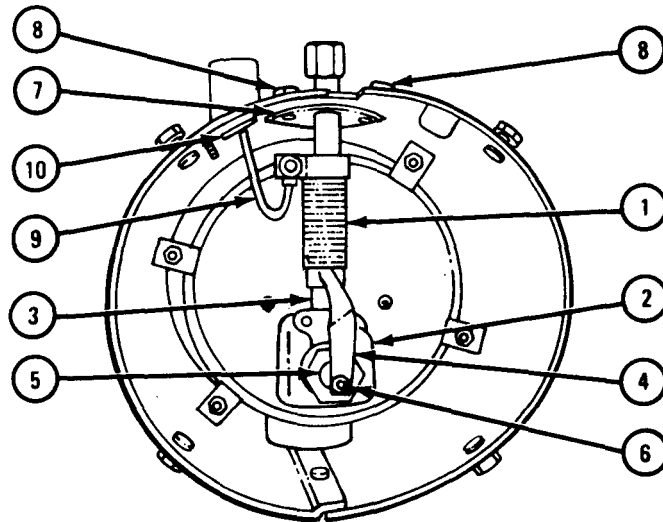

TA 104162

FRAME 6

1. Put igniter ground wire (1) and ground strap (2) in place on burner (3). Screw in and tighten screw, lockwasher, and nut (4).
2. Put ground strap (2) on stud (5). Screw on and tighten nut and lockwasher (6).
3. Put preheat resistor electrical lead (7) on preheat resistor terminal (8). Screw in and tighten screw, lockwasher, and nut (9).

GO TO FRAME 7

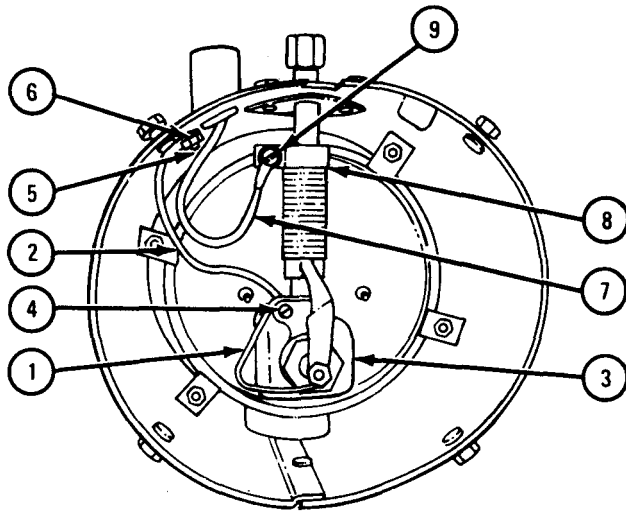

TA 104163

FRAME 7

1. Put end plate (1) on housing (2) as shown. Be sure four slots (3) engage four studs (4).
2. Turn end plate (1) so studs (4) engage bayonet slots (5). Tighten four nuts (6).

GO TO FRAME 8

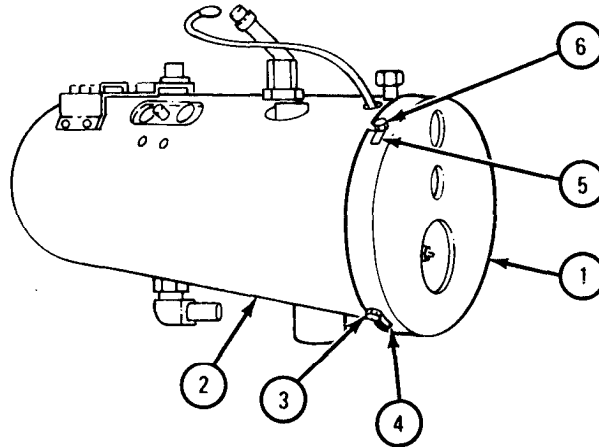

TA 104164

FRAME 8

1. Put new preformed packing (1) on overheat thermostat (2). Put overheat thermostat (2) and cover (3) on heater (4).
2. Put lockwasher (5) on stud (6). Screw on and tighten nut (7).
3. Put fuel control valve (8) on fuel standpipe (9). Screw on and tighten fitting (10).

GO TO FRAME 9

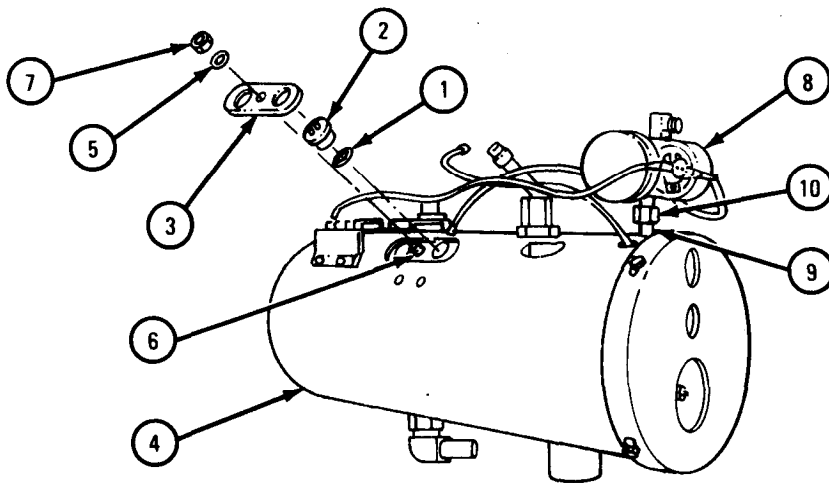

TA 104165

FRAME 9

1. Take out terminal screw (1) on overheat thermostat (2). Put on two overheat thermostat electrical leads (3 and 4). Screw in and tighten terminal screw (1).
2. Do step 1 again for terminal screw (5) on overheat thermostat (2) and electrical leads (6 and 7).
3. Take out terminal screw (8) on terminal strip (9). Put on fuel control valve electrical lead (10) on terminal strip (9). Screw in and tighten terminal screw (8).

GO TO FRAME 10

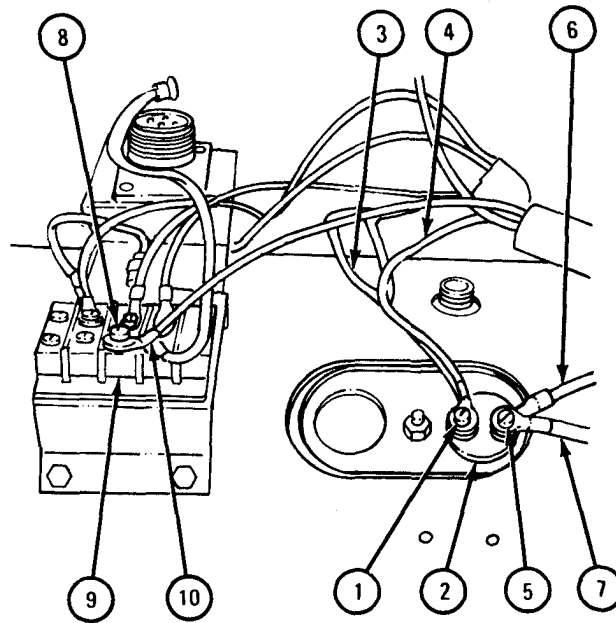

TA 104166

FRAME 10

CAUTION

Use care in putting flame detector switch (1) back into housing (2). Quartz rod in switch (1) may break if you are not careful.

1. Put flame detector switch (1) into housing (2). Screw on and tighten fitting (3) under flame detector switch (1).
2. Unscrew and take out terminal screw (4). Put flame detector switch common electrical lead (5) on common terminal of flame detector switch (1). Screw in and tighten terminal screw (4).
3. Do step 2 again for middle terminal screws (6 and 7) and end terminal screws (8 and 9) on flame detector switch (1).

GO TO FRAME 11

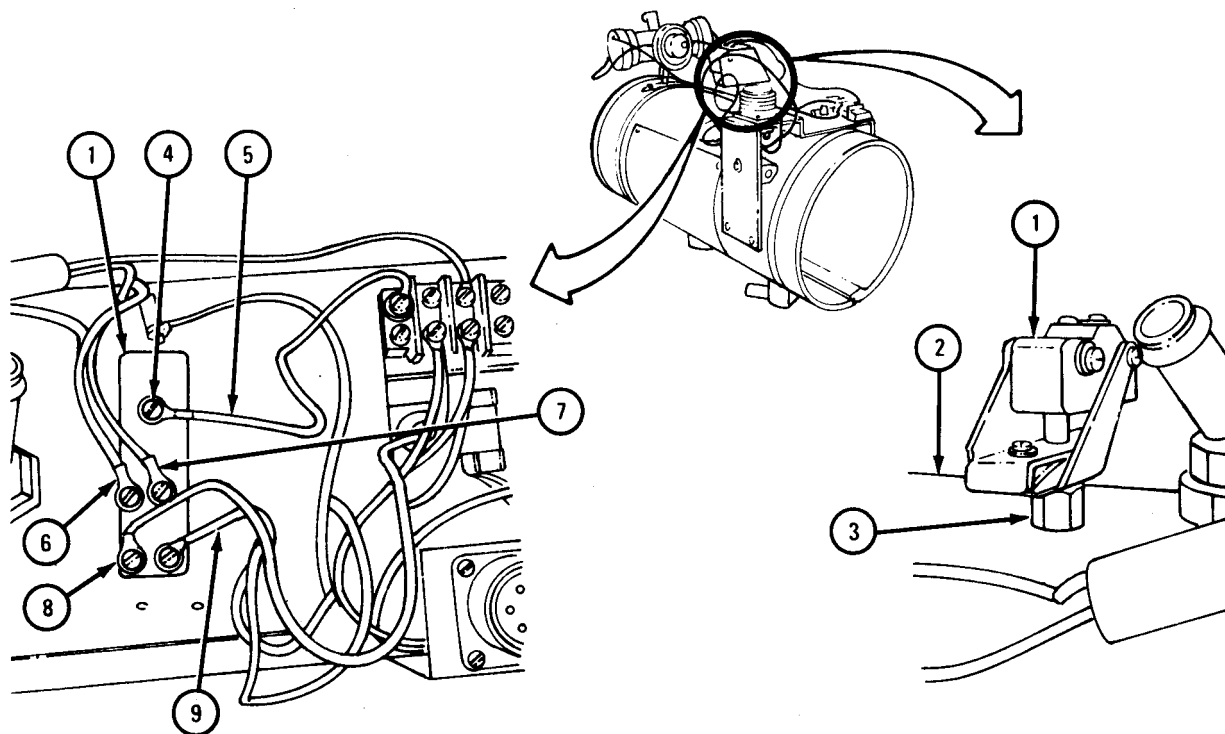

TA 104167

FRAME 11

1. Align scratch marks (1) on blower assembly (2) and housing (3). Put blower assembly (2) on housing (3).
2. Turn blower assembly (2) so studs (4) engage slots (5). Tighten nuts (6).
3. Unscrew and take out terminal screw (7). Put on blower motor electrical lead (8). Screw in and tighten terminal screw (7).

GO TO FRAME 12

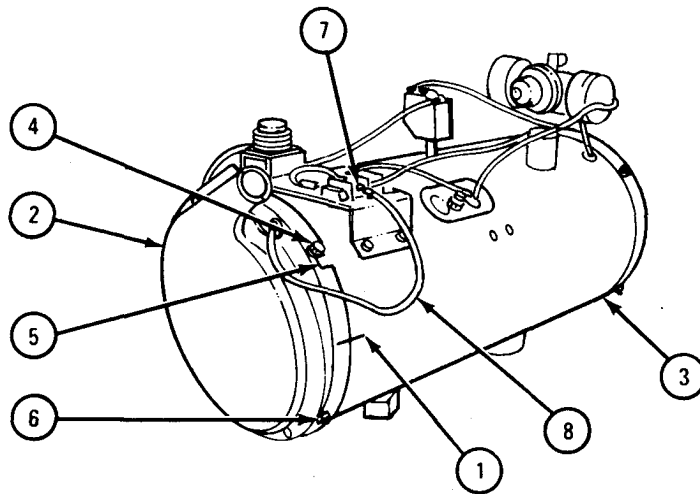

TA 104169

FRAME 12

1. Put on air inlet tube and elbows (1). Put on ground electrical lead (2). Screw on and tighten nut (3).
2. Put on guard (4). Screw in and tighten four screws (5), two on each end of guard (4).

END OF TASK

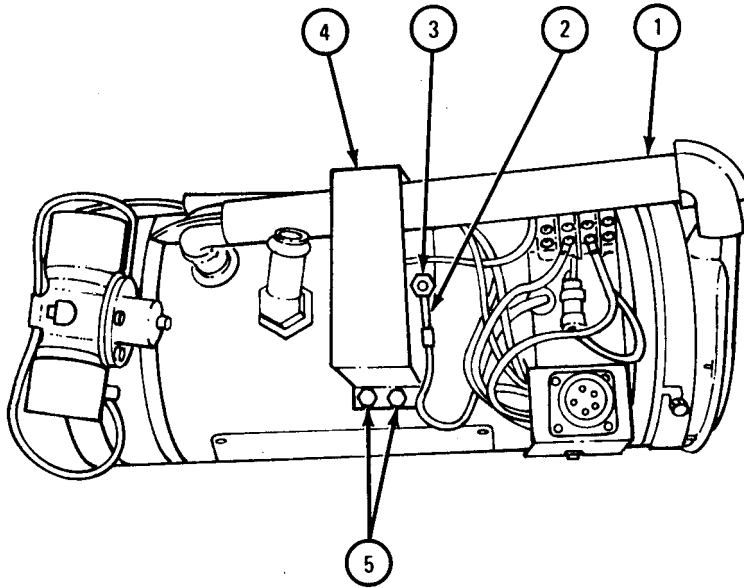

TA 104170

f. Replacement.

FRAME 1

WARNING

Smoking, sparks or open flames are not allowed within 50 feet of work area during this task. Fuel can explode, causing injury to personnel and damage to equipment.

1. Working in battery box, put heater assembly (1) into two retainer clamps (2). Close and screw tight two retainer clamps (2).
2. Plug in and screw on tight electrical connector (3).
3. Slide exhaust pipe elbow (4) onto heater (1). Put in cotter pin (5). Bend over ends of cotter pin (5).
4. Put fuel line (6) on fuel control valve (7). Screw on and tighten fitting (8).
5. Turn on fuel cock (9).

NOTE

Follow-on Maintenance Action Required:

1. Put on coolant hoses at heater. Refer to TM 9-2320-209-20.
2. Connect battery ground cable. Refer to TM 9-2320-209-20.
3. Check all fuel lines and coolant hoses for coolant and fuel leaks.

END OF TASK

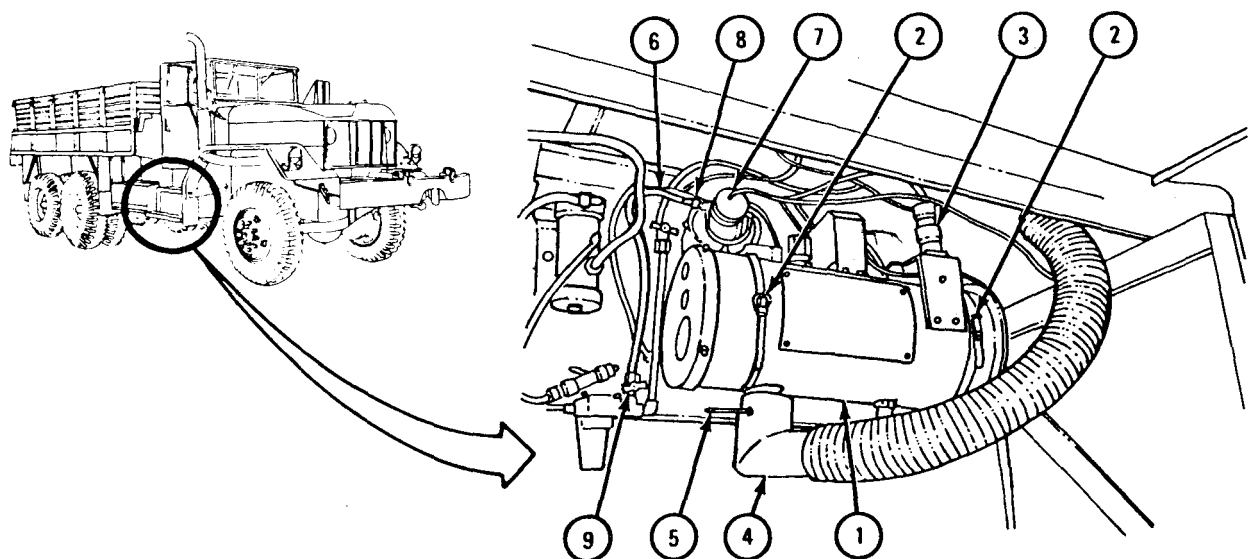

TA 104171

21-7. FUEL BURNING PERSONNEL HEATER INSTALLATION. Install fuel burning personnel heater using instructions that come with kit.

21-8. FUEL BURNING PERSONNEL HEATER TEST. For procedures to test the fuel burning personnel heater, refer to ST 9-914.

21-9. FUEL BURNING PERSONNEL HEATER REMOVAL, REPAIR, TEST, AND REPLACEMENT.

TOOLS: No special tools required

SUPPLIES: Solvent, dry cleaning, type II (SD-2), Fed. Spec P-D-680
Compressed air source, 30 psi max
Tags
Clean rags
Fuel control valve cover plate gasket
Fuel control valve orifice plate gasket

PERSONNEL: One

a. Preliminary Procedures.

(1) Open hood and side panels. Refer to TM 9-2320-209-10.

(2) Disconnect battery ground. Refer to TM 9-2320-209-20.

(3) Shut off personnel heater fuel cock. Refer to Operating the Fuel Burning Personnel Heater, TM 9-2320-209-10.

b. Removal.

FRAME 1

1. Take off harness lead (1).
2. Take off fuel line (2).
3. Loosen two screws (3).

NOTE

One of two screws (3) is under cover (4) and can be seen through hole in cover.

4. Take off cover (4).
5. Loosen hose clamp (5).
6. Take off two hose clamps (6).
7. Take off heater (7).

END OF TASK

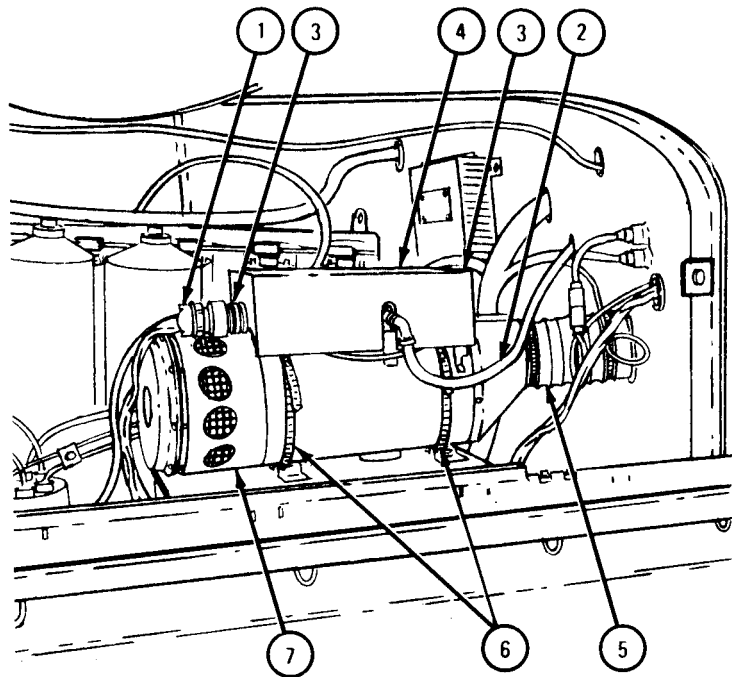
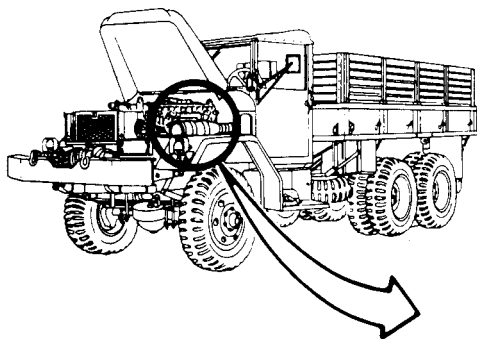

TA 118473

c. Disassembly.

NOTE

Tag all wires before taking them off so they can be put back the same way.

FRAME 1

1. Take out four screws (1).
2. Pull blower (2) away from body (3).
3. Take out screw (4).
4. Take out four screws (5).
5. Takeoff outlet duct (6) from body (3).

GO TO FRAME 2

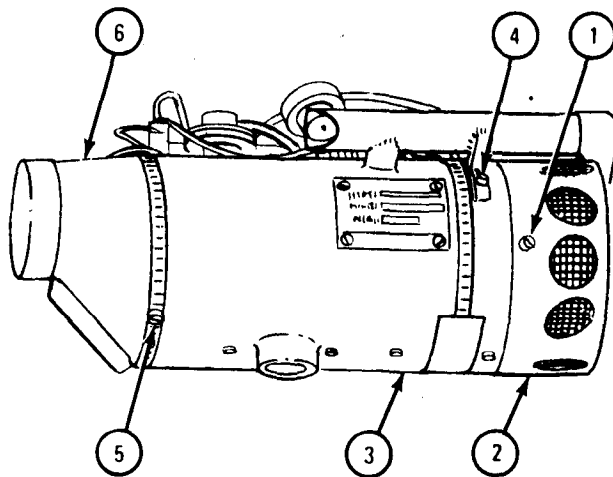

TA 118474

FRAME 2

1. Take out screw (1). Take off wires (2) and (3).
 2. Take off screw and nut (4).
 3. Take off wire (5).
 4. Take out screw (6) and take off wire (7).
 5. Set blower assembly (8) to one side. It will be taken apart later.
- GO TO FRAME 3

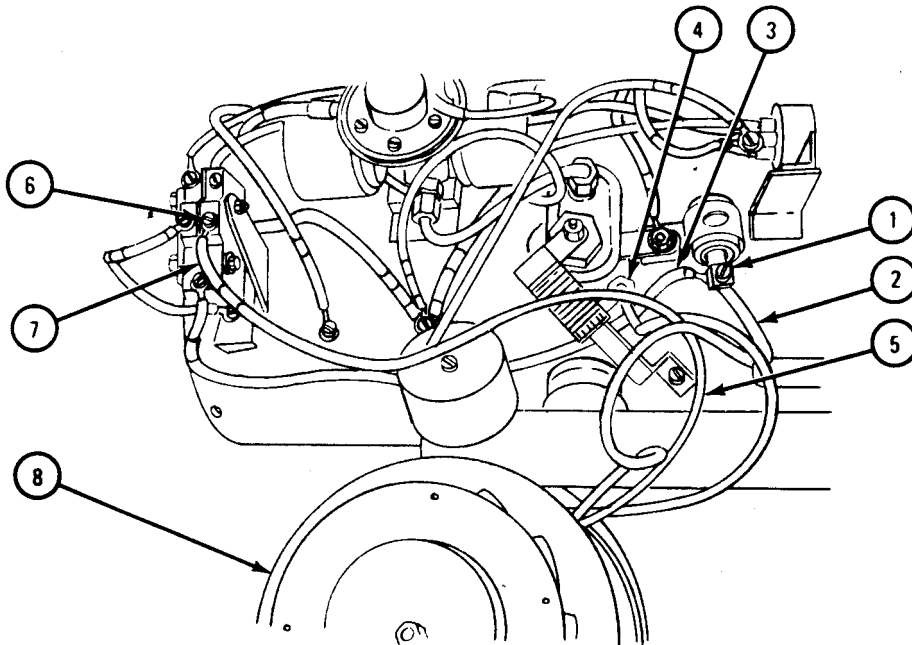

TA 118475

FRAME 3

1. Take out screw (1). Take off wire (2).
2. Take off tube (3).
3. Loosen two tube nuts (4). Take off fuel line (5).
4. Take off nut (6).
5. Take off resistor (7).
6. Unscrew and take out glow plug (8).

GO TO FRAME 4

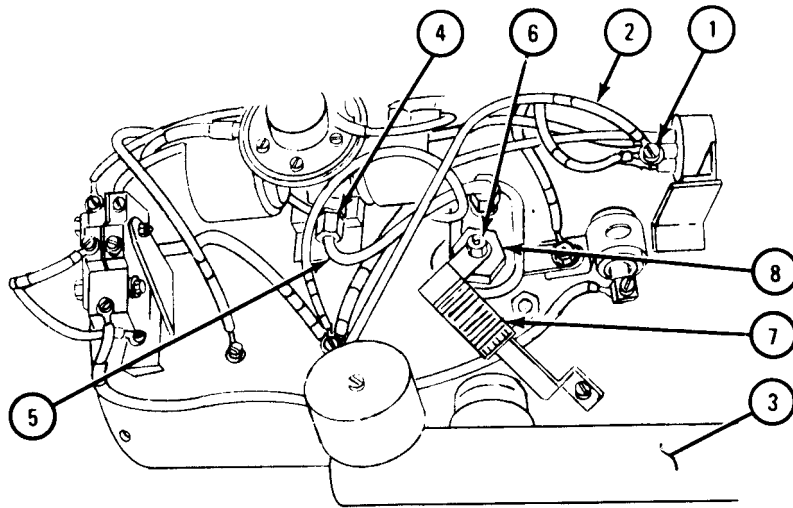

TA 118476

FRAME 4

1. Take off two nuts (1).
2. Take off four wires (2).
3. Take out screw (3). Take off wire (4).
4. Take out three screws (5). Take off three wires (6).
5. Take out two screws (7). Take off overtemperature switch (8).

GO TO FRAME 5

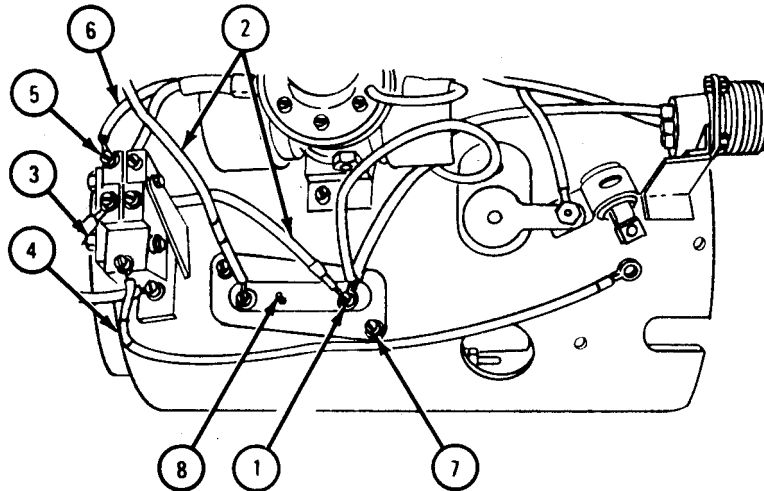

TA 118477

FRAME 5

1. Takeoff nut (1). Takeoff condenser (2) and tab (3).
2. Take out screw (4). Take off bracket (5).
3. Take out four screws (6).
4. Takeoff fuel control valve (7).
5. Take out four screws (8).
6. Take off connector plug (9).

GO TO FRAME 6

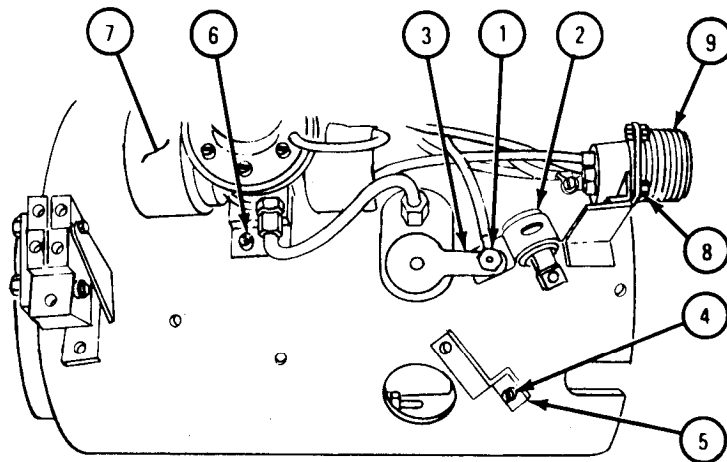

TA 118478

FRAME 6

1. Take out three screws (1).
2. Spring open but do not bend shell (2).
3. Take out chamber (3) from shell (2).

GO TO FRAME 7

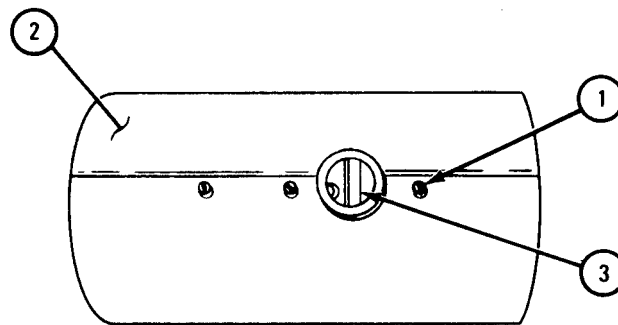

TA 118479

FRAME 7

1. Take out flame detector switch assembly (1).
2. Scribe a line on cover (2), end plate (3), and body (4) so they can be put back the same way.
3. Take out pipe nipple (5).
4. Loosen four nuts (6), Take off four clamps (7).
5. Take off cover (2).
6. Take off end plate (3).

GO TO FRAME 8

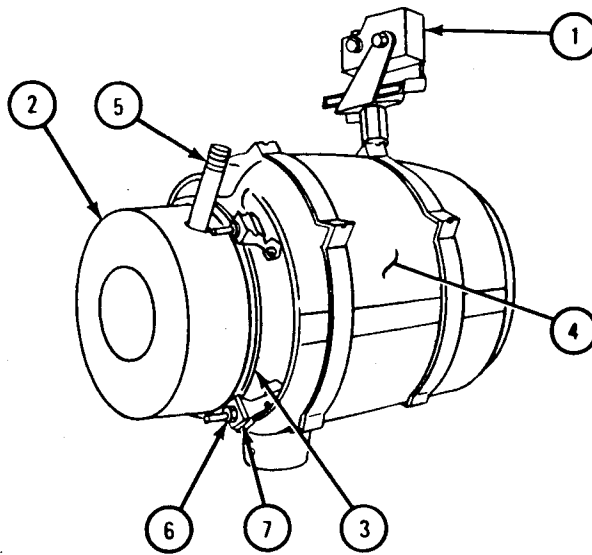

TA 118480

FRAME 8

1. Take off eight screws (1) and nuts (2).
2. Take off elbow (3).
3. Take off blower cover (4).
4. Loosen setscrew (5) and take off blade (6).
5. Take off two nuts (7) and frame (8).

GO TO FRAME 9

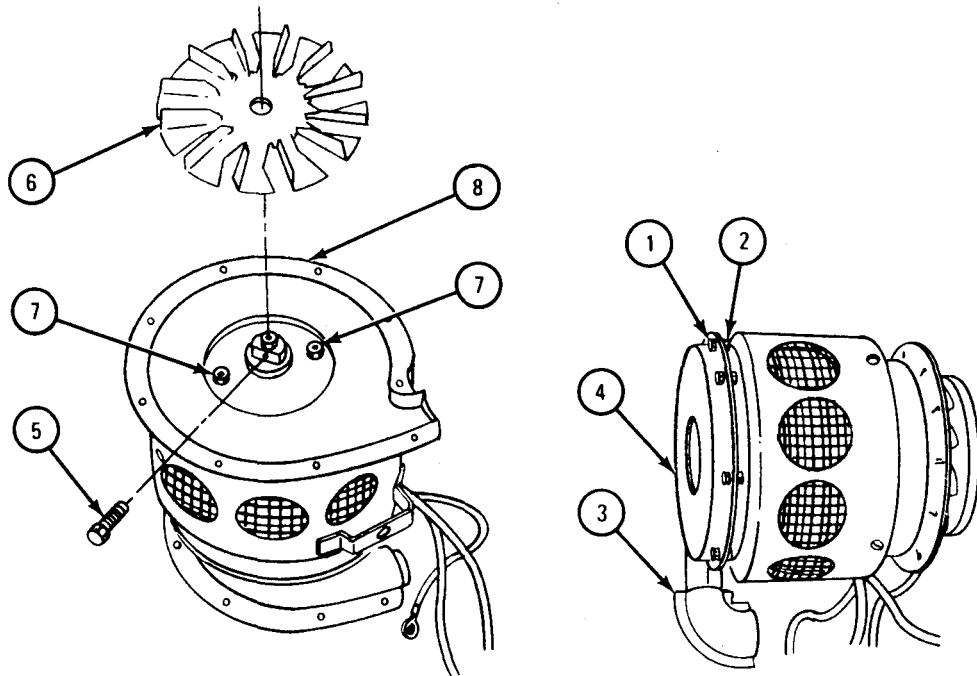

TA 118701

FRAME 9

1. Looking at end of blower, find flat side of shaft (1).
2. Put hex socket wrench (2) through hole in fan (3) opposite flat spot and loosen setscrew (4).
3. Take off fan (3).

GO TO FRAME 10

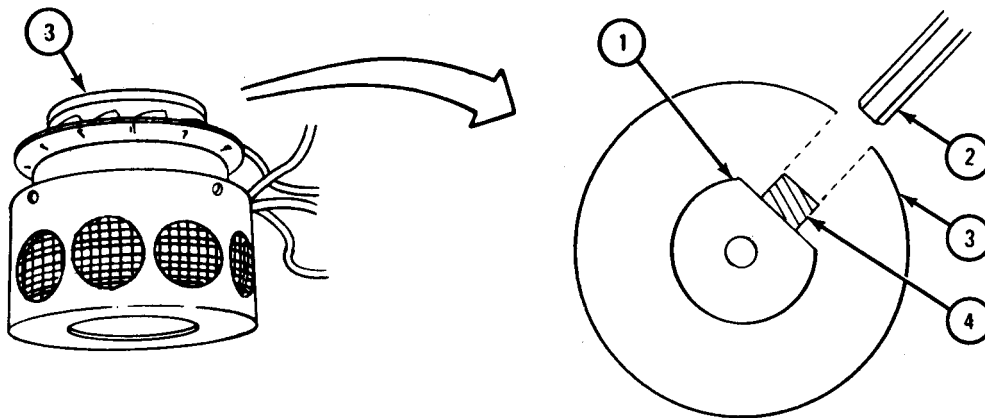

TA 118702

FRAME 10

1. Take out four screws (1).
 2. Take motor (2) out of frame (3).
- END OF TASK

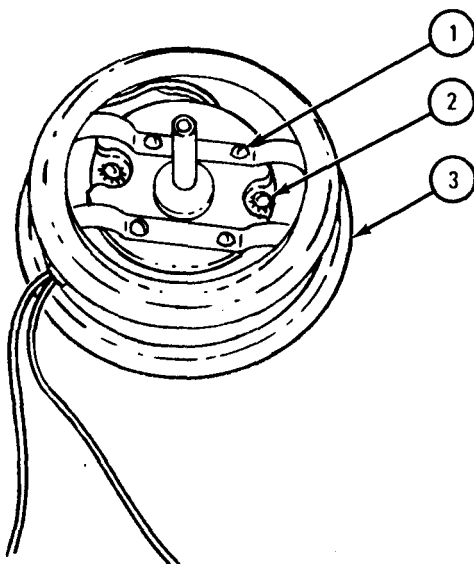

TA 118703

d. Disassembly, Inspection, Assembly, and Adjustment of Flame Detector Switch.

FRAME 1

CAUTION

Do not dip flame detector switch (1) in solvent.
Electrical parts may be damaged by doing so.

1. Wipe flame detector switch (1) with cloth dipped in dry cleaning solvent. Wipe flame detector switch dry.
2. Unscrew and take out adjusting screw and washer (2). Loosen screws (3).
3. Flip up microswitch (4) and take off bow spring (5).

CAUTION

Do not let quartz rod (6) fall out of flame detector switch (1). Do not drop quartz rod. Letting it fall or dropping it may break or chip quartz rod.

4. Turn flame detector switch (1) over and let quartz rod (6) slide out of tube (7). Tap bottom of tube to get out any broken pieces of quartz rod.

GO TO FRAME 2

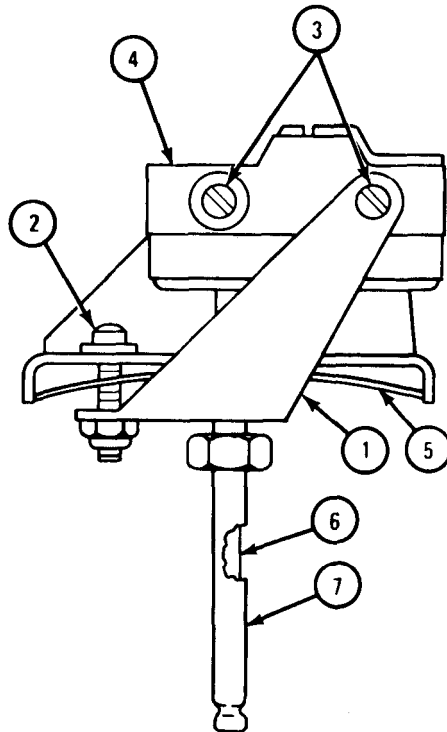

TA 118705

FRAME 2

1. Clean tube (1) of flame detector switch (2) with wire brush. Check that tube is straight. Get new flame detector switch (2) if tube is not straight.
2. Clean bow spring (3) with wire brush. Check that bow spring is straight. Get new flame detector switch (2) if bow spring is bent.
3. Check that microswitch (4) clicks by pressing in on shaft (5). Microswitch should also click when shaft is let out. Get new flame detector switch (2) if microswitch does not click.
4. Check that quartz rod (6) is not broken or shipped. Get new quartz rod if it is broken or chipped.

GO TO FRAME 3

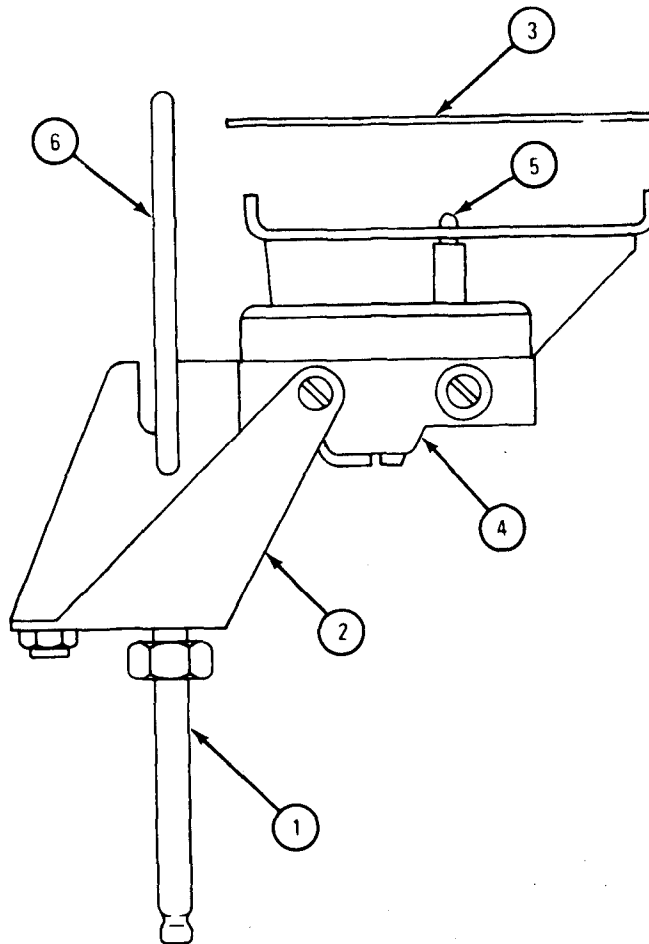

TA 118706

FRAME 3

1. Slide quartz rod (1) into tube (2) of flame detector switch (3). Place bow spring (4) on microswitch frame (5). Flip microswitch (6) down into place.
2. Screw in adjusting screw and washer (7) and push up on bow spring (4) while tightening adjusting screw.
3. Tighten screws (8) just enough so microswitch (6) is held in place.
4. Slowly unscrew adjusting screw (7) until microswitch (6) clicks. Slowly screw in adjusting screw until microswitch clicks. Screw in adjusting screw exactly three-quarters turn more.
5. Tighten screws (8).

END OF TASK

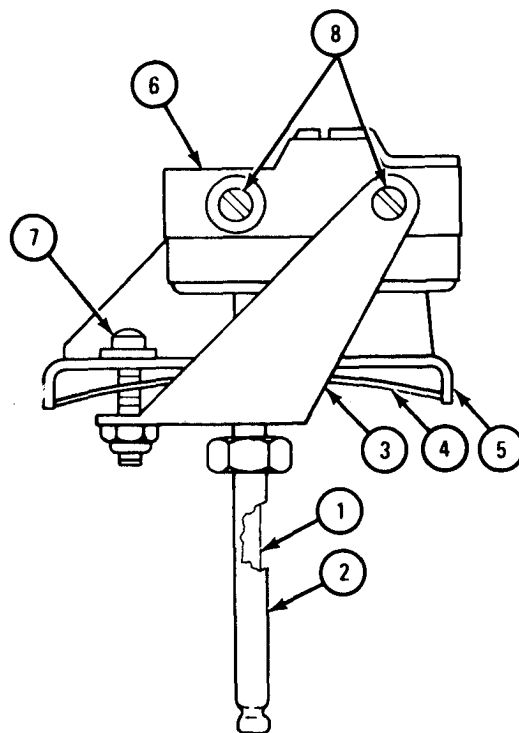

TA 118707

e. Disassembly, Inspection, Repair, Assembly, and Test of Fuel Control Valve.

FRAME 1

CAUTION

Do not dip fuel control valve (1) in dry cleaning solvent. Electrical parts may be damaged by doing so.

1. Wipe fuel control valve (1) clean with a clean cloth dipped in dry cleaning solvent, wipe fuel control valve dry.
2. Check that fuel control valve (1) has no cracked or broken parts. If cracks or breaks are found, do step 6.
3. Check that electrical leads (2, 3, 4, 5, 6, and 7) have no broken or frayed insulation or damaged connectors on ends. If any electrical leads or connectors are damaged, do step 6.
4. Using ohmmeter, check continuity through heater by placing one ohmmeter lead on terminal (8) and other ohmmeter lead on terminal (9). Circuit should be closed. If circuit is open, do step 6.
5. If fuel control valve (1) passes tests, go to frame 2. If you must get new fuel control valve, do step 6.

NOTE

Electrical leads (2 and 7) must be used on new fuel control valve (1).

6. Unscrew and take off nut (10). Take off electrical lead (2) and slide off electrical lead (7). Get new fuel control valve (1).

END OF TASK

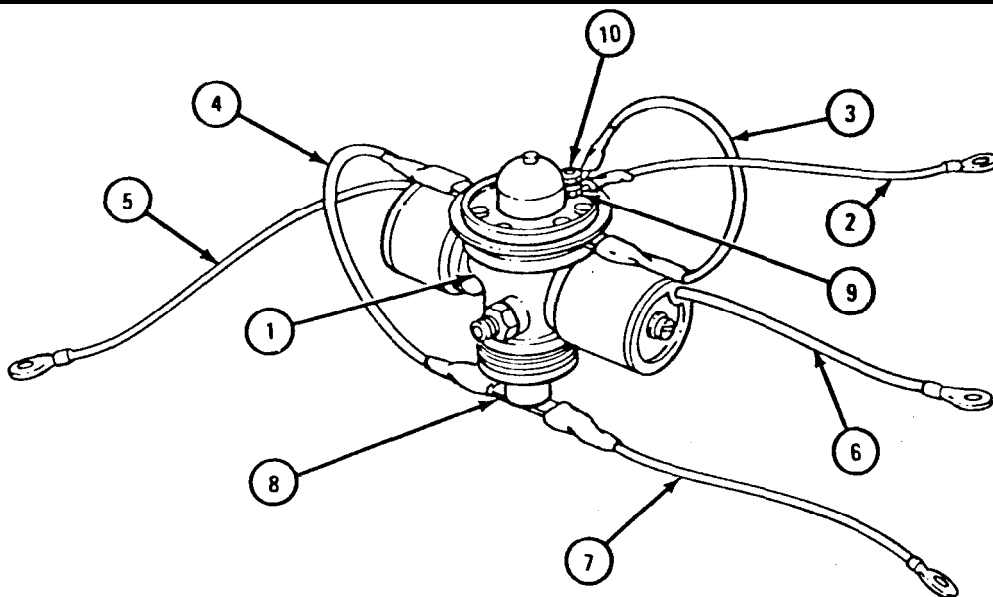

TA 118708

FRAME 2

1. Heat thermostat (1) to between 75°F and 80°F.
2. Using ohmmeter, check continuity through thermostat (1) by placing one lead on terminal (2) and other lead on terminal (3).

IF CIRCUIT IS OPEN, GO TO FRAME 3.

IF CIRCUIT IS CLOSED, THROW PART AWAY AND GET NEW ONE. END OF TASK

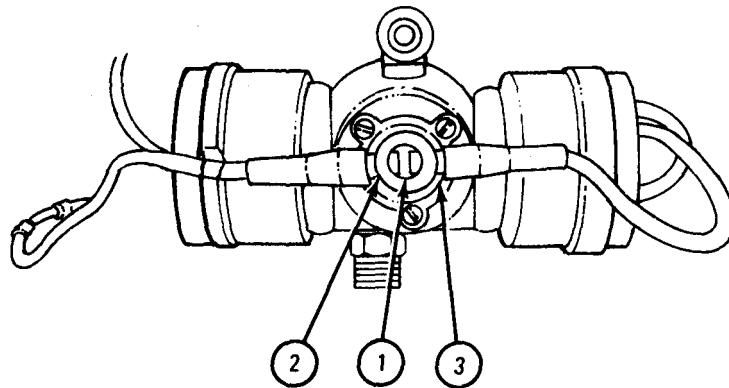

TA 118711

FRAME 3

1. Cool thermostat (1) at 20°F for 30 minutes.
2. Using ohmmeter, check continuity through thermostat (1) by placing one lead on terminal (2) and other lead on terminal (3).

IF CIRCUIT IS CLOSED, GO TO FRAME 4.

IF CIRCUIT IS OPEN, THROW PART AWAY AND GET NEW ONE. END OF TASK

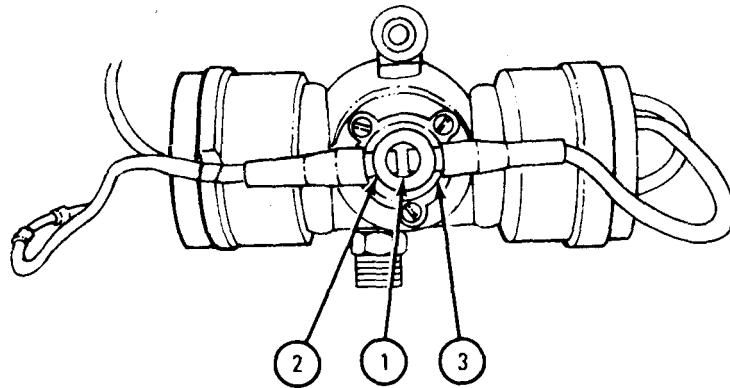

TA 118711

FRAME 4

1. Take out fuel inlet fitting (1).
2. Check that screen (2) is not dirty or clogged.
3. If screen (2) is dirty or clogged, throw away fuel control valve (3) and get a new one. If new fuel control valve is needed, END OF TASK.
4. If screen (2) is not dirty or clogged, put in fuel inlet fitting (1).

GO TO FRAME 5

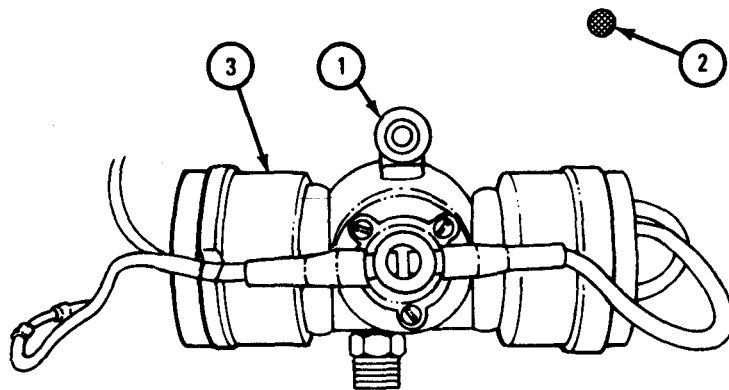

TA 118712

FRAME 5

1. Take off two leads (1).
2. Take out three screws (2). Take off clamp (3) and thermostat (4).
3. Take off cover plate (5), gasket (6), orifice plate (7), and gasket (8). Throw away gaskets.

WARNING

Eye shields must be worn when using compressed air.
Eye injury can occur if **eye shields are not used**.

CAUTION

Do not force anything through openings in orifice plate (7). Damage to orifice plate can cause over-heating.

4. Clean orifice plate (7) and cover plate (5) with compressed air.
5. Check that orifice plate (7) and cover plate (5) have no cracks or burrs. If parts are damaged, throw parts away and get new ones.

GO TO FRAME 6

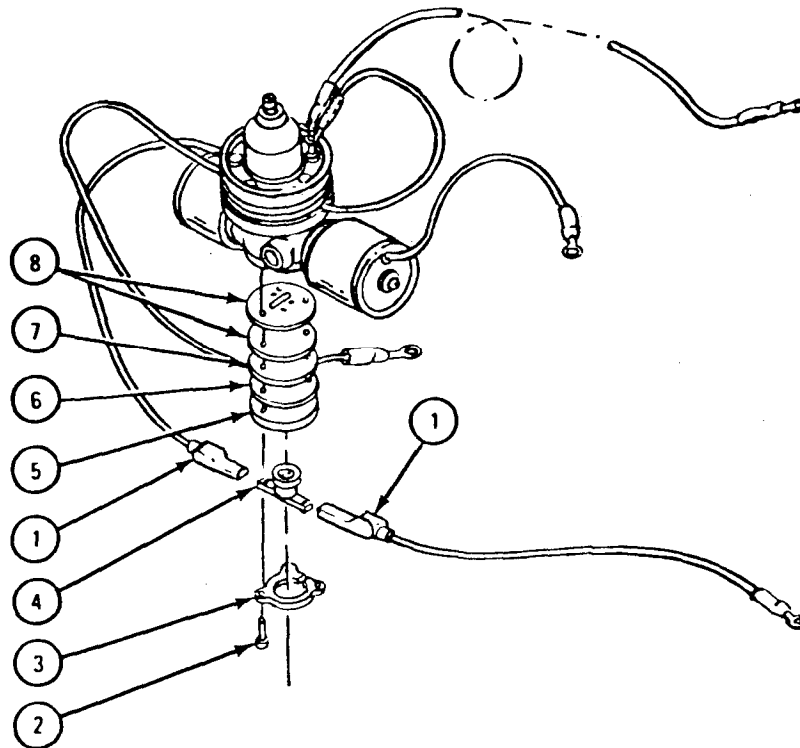

TA 118713

FRAME 6

NOTE

Put gasket (1), orifice plate (2), and gasket (3) on cover plate (4) as shown. Put orifice plate and gasket assembly (5) on fuel control valve (6) as shown.

1. Put gasket (1), orifice plate (2), and gasket (3) on cover plate (4).
2. Put orifice plate and gasket assembly (5) on fuel control valve body (6).
3. Put thermostat (7) and clamp (8) on orifice plate and gasket assembly (5).
4. Screw in and finger tighten three screws (9). Tighten three screws evenly, tightening each one a little at a time.
5. Slide two electrical leads (10) on terminals.

GO TO FRAME 7

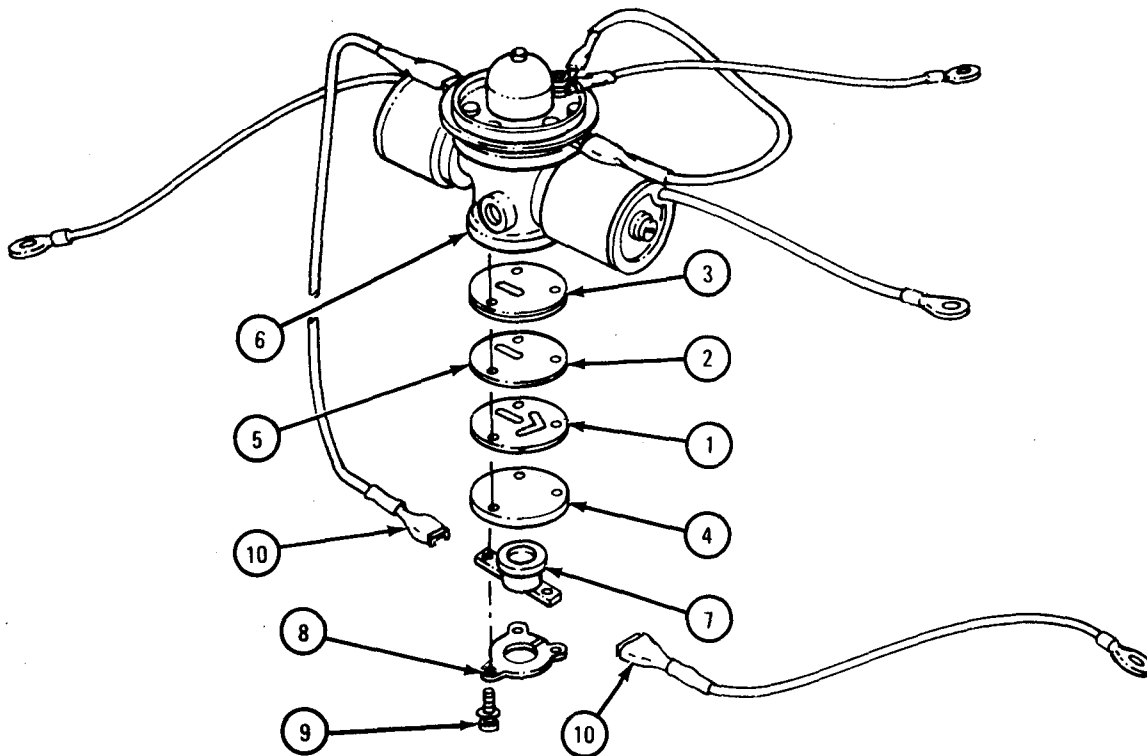

TA 118714

FRAME 7

CAUTION

Fuel flow and leak tests must be done with fuel control valve in position it normally works in. Fuel used must be of type normally used. Failure to do this could result in a wrong measurement, causing serious damage to equipment.

1. Join fuel supply line (1) to fuel inlet fitting (2).
2. Using suitable electrical lead (3), join shutoff electrical lead (4) and restrictive electrical lead (5) together. Join other end of lead (3) to pin B (6) of wiring harness connector (7).
3. Using suitable electrical lead (8), join body of fuel control valve (9) to pin A (10) of wiring harness connector (7).

GO TO FRAME 8

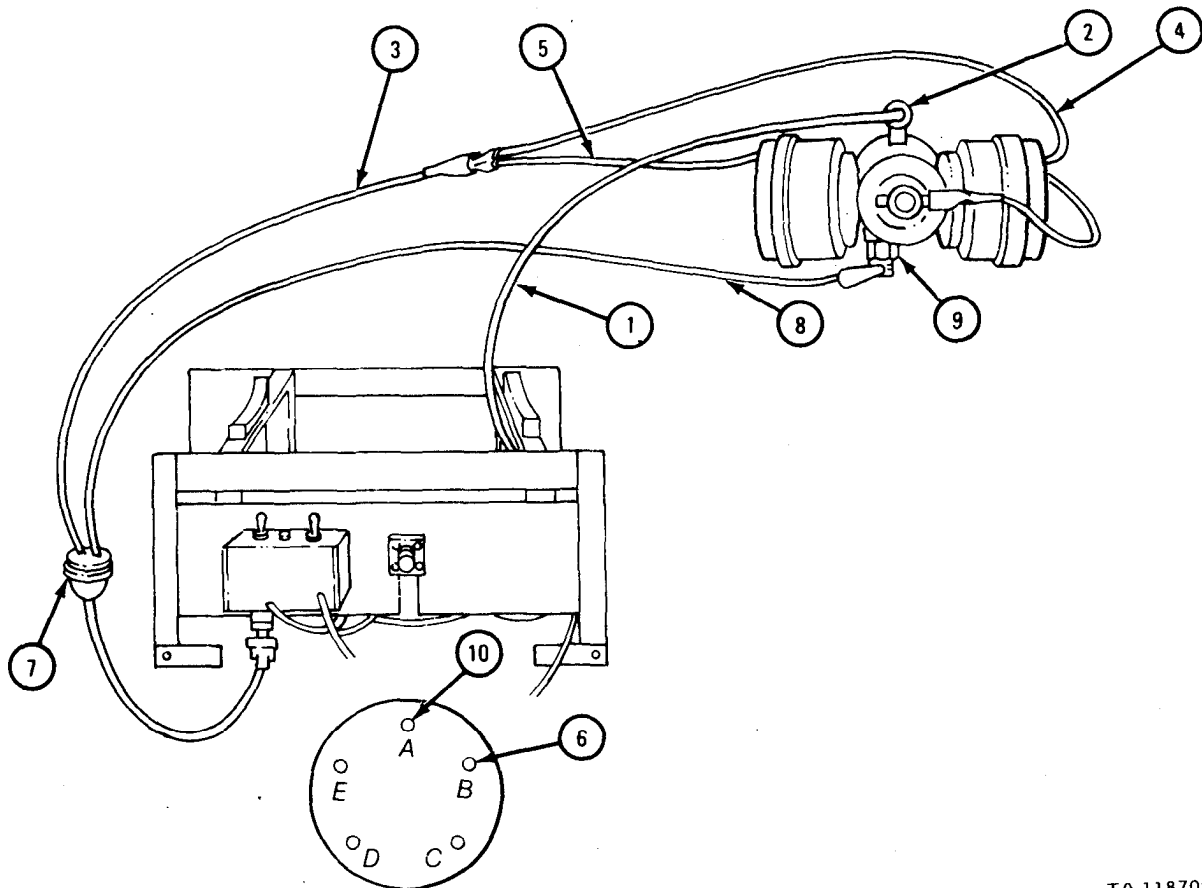

TA 118709

FRAME 8

1. Put control switch (1) in OFF position. Put HI-LO switch (2) in LO position.
2. Join power supply lead (3) to position (+) battery terminal (4). Join ground lead (5) to negative (-) battery terminal (6).

GO TO FRAME 9

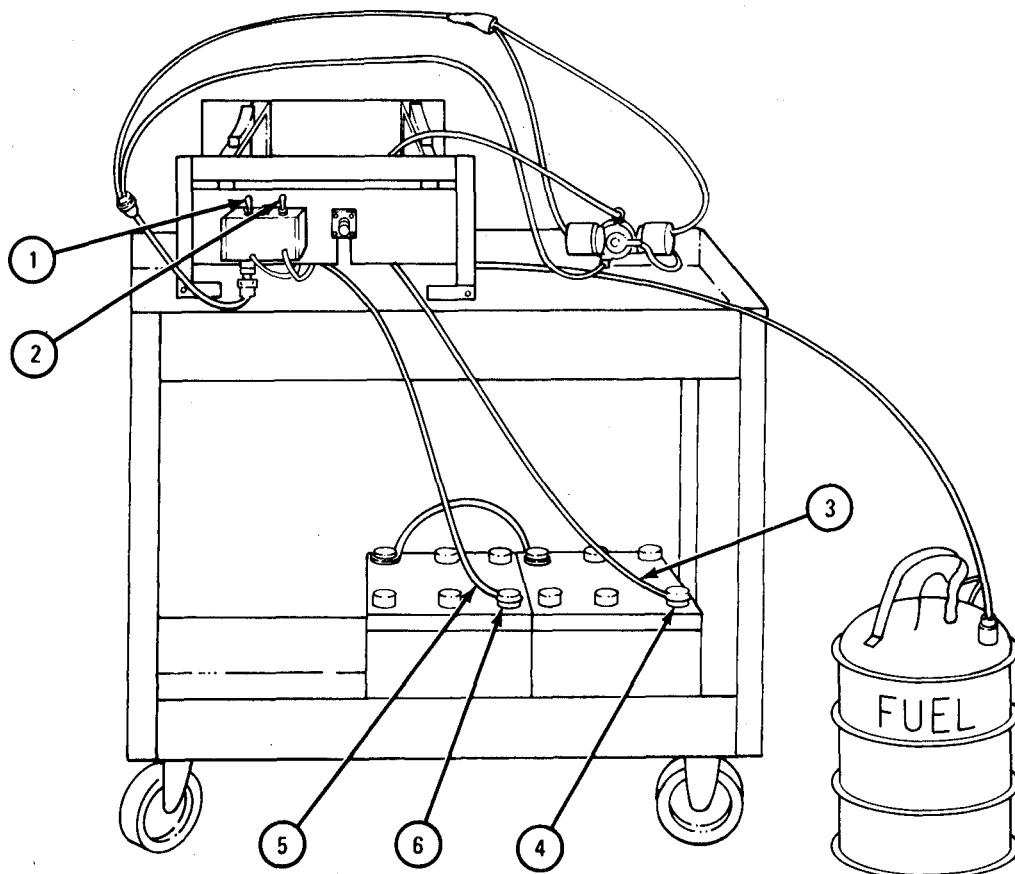

TA 104175

FRAME 9

NOTE

Use container (3) to catch overflow for this test.

1. Hold fuel outlet (1) of fuel control valve (2) over overflow container (3).
2. Make sure HI-LO switch (4) is in LO position. Flip control switch (5) to RUN position. Fuel pump should be pumping.
3. Flip HI-LO switch (4) to HI. Let fuel flow into overflow container (3) for a few seconds. Flip HI-LO switch (4) to LO position.
4. Look at fuel outlet (1) for one minute. One or two drops may form, but fuel flow must be completely stopped.
5. Do steps 1 through 4 again. Flip control switch (5) to OFF position.
6. If fuel flow does not stop completely when HI-LO switch (4) is flipped to LO position, get new fuel control valve (2).

IF FUEL CONTROL VALVE PASSES TEST, GO TO FRAME 10.

IF FUEL CONTROL VALVE FAILS TEST, GET A NEW ONE. END OF TASK

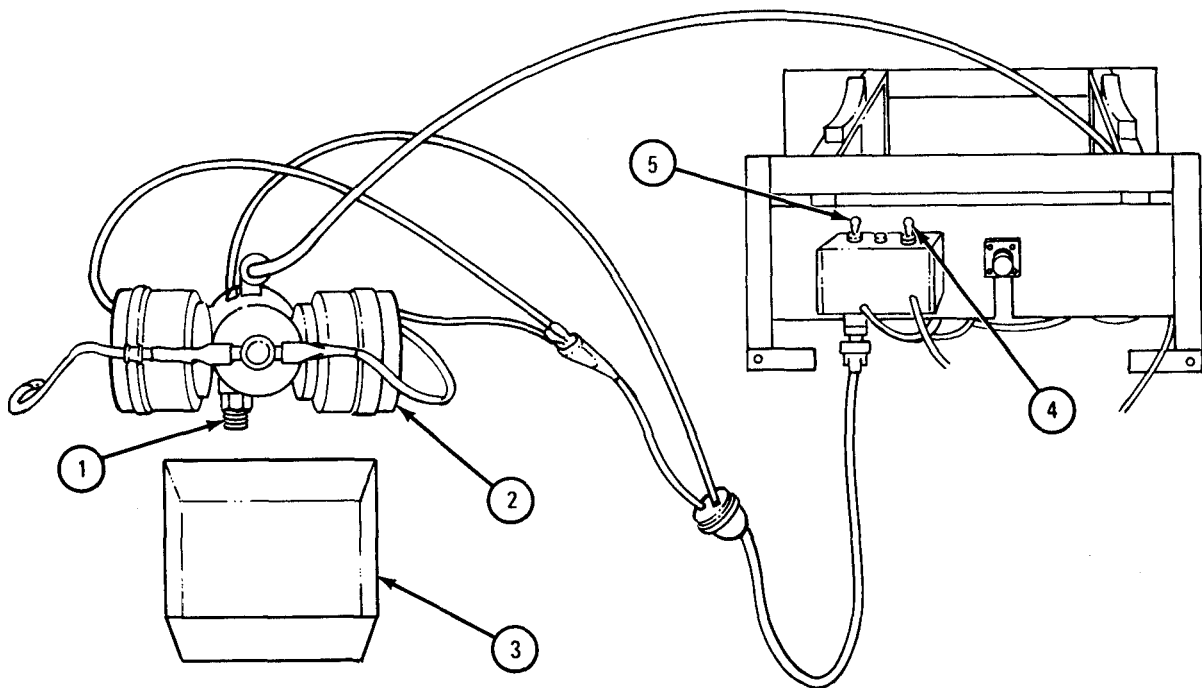

TA 104177

FRAME 10

NOTE

Fuel flow test and adjustment should be done even on new fuel control valve. Fuel control valve must be set for use with different fuels. A stopwatch or watch with a second hand is needed for this test.

1. Hold fuel outlet (1) of fuel control valve (2) over overflow container (3).
2. Make sure HI-LO switch (4) is in LO position. Flip control switch (5) to RUN position. Fuel pump should be pumping.
3. Flip HI-LO switch (4) to HI. Let fuel flow into overflow container (3) for a few seconds.
4. Let fuel flow into graduate (6) for exactly one minute. Flip HI-LO switch (4) to LO position. Flip control switch (5) to OFF position.
5. Place graduate (6) on a level surface. Read level of fuel (7) as shown. Level of fuel should be within limits given in table for type of fuel used.

Fuel Type	Diesel Fuel			Combat Gasoline
	DFA	DF1	DF2	
Flow Rate (cc/min)	14 to 18	14 to 18	15 to 19	15 to 19

IF FUEL FLOW IS WITHIN GIVEN LIMITS, GO TO FRAME 11.
 IF FUEL FLOW IS NOT WITHIN GIVEN LIMITS, GET NEW FUEL CONTROL VALVE.
 END OF TASK

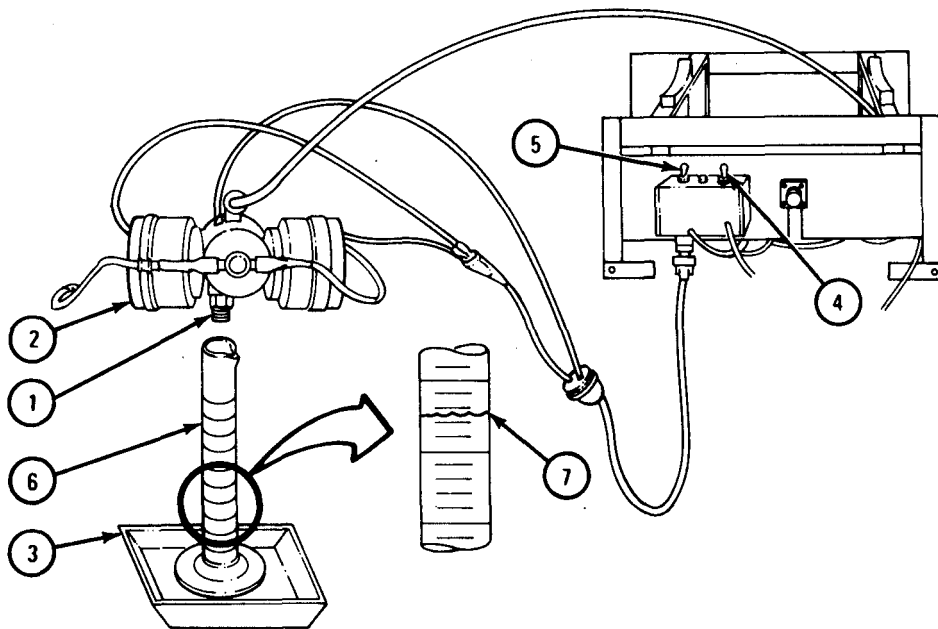

TA 104178

FRAME 11

1. Take restriction electrical lead (1) out of clip (2).
2. Hold fuel outlet (3) of fuel control valve (4) over overflow container (5).
3. Make sure HI-LO switch (6) is in LO position. Flip control switch (7) to RUN position. Fuel pump should be pumping.
4. Flip HI-LO switch (6) to III position. Let fuel flow into overflow container (5) for a few seconds.
5. Let fuel flow into graduate (8) for exactly one minute. Flip HI-LO switch (6) to LO position. Flip control switch (7) to OFF position.
6. Place graduate (8) on a level surface. Read level of fuel (9) as shown. Level of fuel should be within limits given in table for type of fuel used.

Fuel Type	Diesel Fuel			Combat Gasoline
	DFA	DF1	DF2	
Flow Rate cc/min)	6 to 8	6.5 to 8.5	6.5 to 8.5	7 to 9

IF FUEL FLOW IS WITHIN GIVEN LIMITS, GO TO FRAME 12.
 IF FUEL FLOW IS NOT WITHIN GIVEN LIMITS, GET NEW FUEL CONTROL VALVE.
 END OF TASK

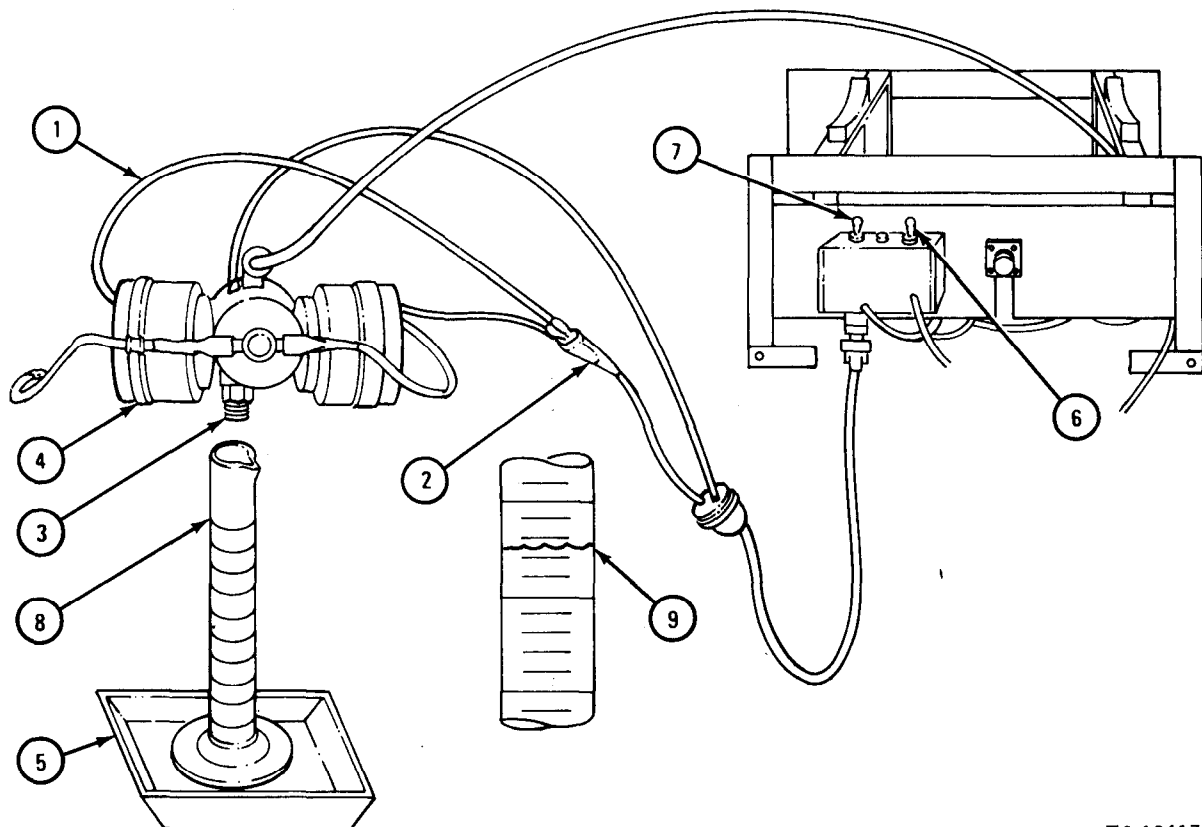

TA 104179

FRAME 12

1. Take off electrical lead (1) from fuel control valve body (2) and from pin A (3) of wiring harness connector (4).
2. Take off electrical lead (5) from fuel control valve leads (6) and from pin B (7) of wiring harness connector (4).
3. Take off fuel supply line (8) from fuel inlet fitting (9).

END OF TASK

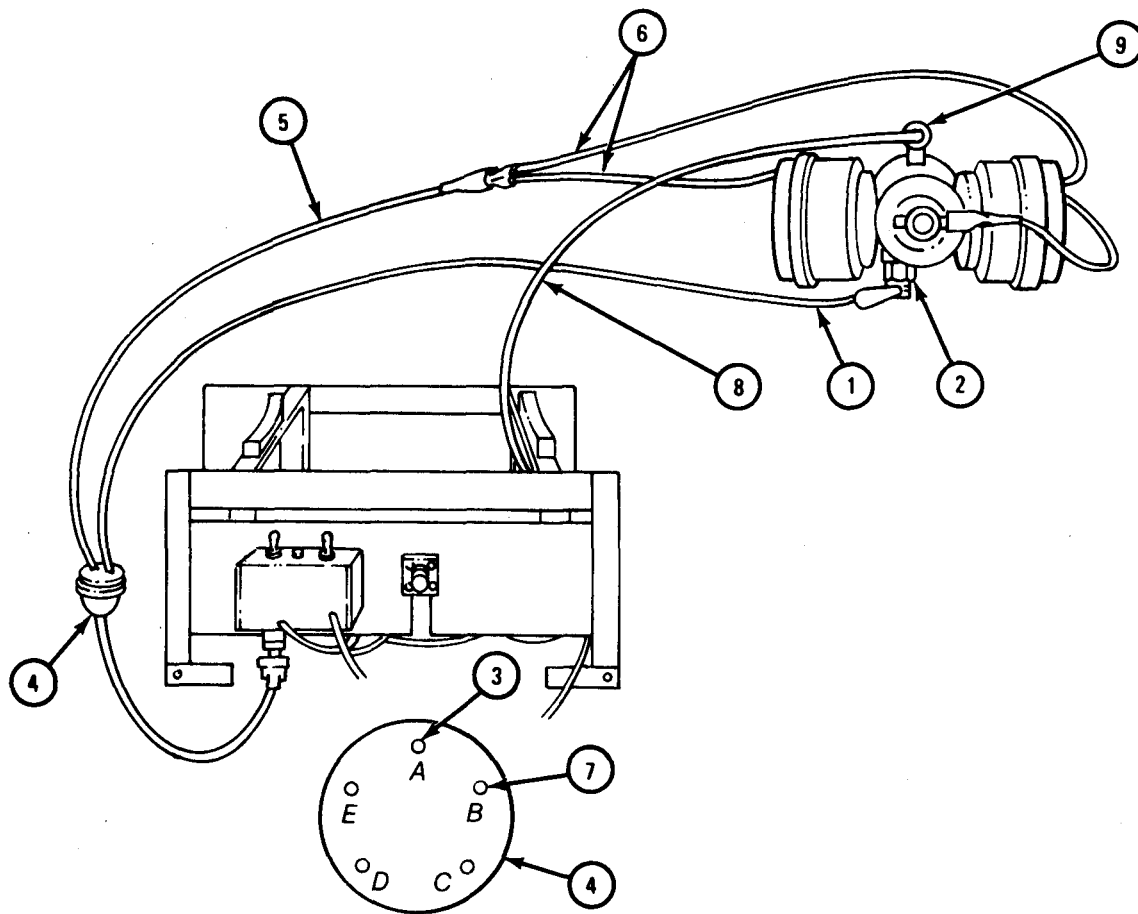

TA 118710

f. General Cleaning, Inspection, and Repair.WARNING

Dry cleaning solvent is flammable. Do not use near an open flame. Keep a fire extinguisher nearby when solvent is used. Use only in well-ventilated places. Failure to do this may result in injury to personnel and damage to equipment.

Eye shields must be worn when using compressed air. Eye injury can occur if eye shields are not used.

- (1) Clean all parts with dry cleaning solvent. Dry with compressed air.
- (2) Check that all parts are not damaged.
- (3) If parts are damaged, throw parts away and get new ones.

g. Assembly.

FRAME 1

1. Put motor (1) in frame (2).
 2. Put in four screws (3).
- GO TO FRAME 2

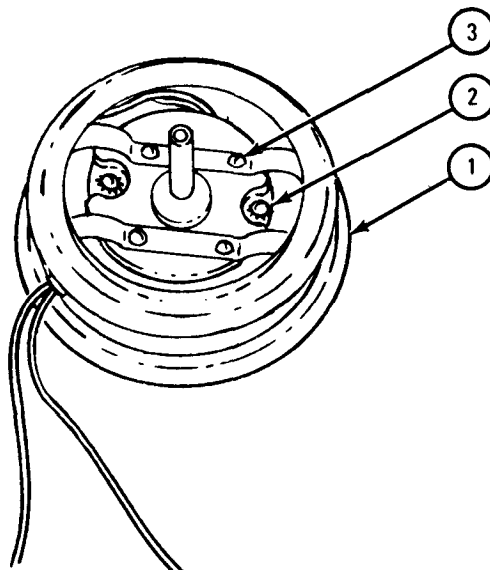

TA 118704

FRAME 2

1. Put fan (1) on blower shaft (2). Align setscrew (3) with flat side of shaft (2).

2. Tighten setscrew (3).

GO TO FRAME 3

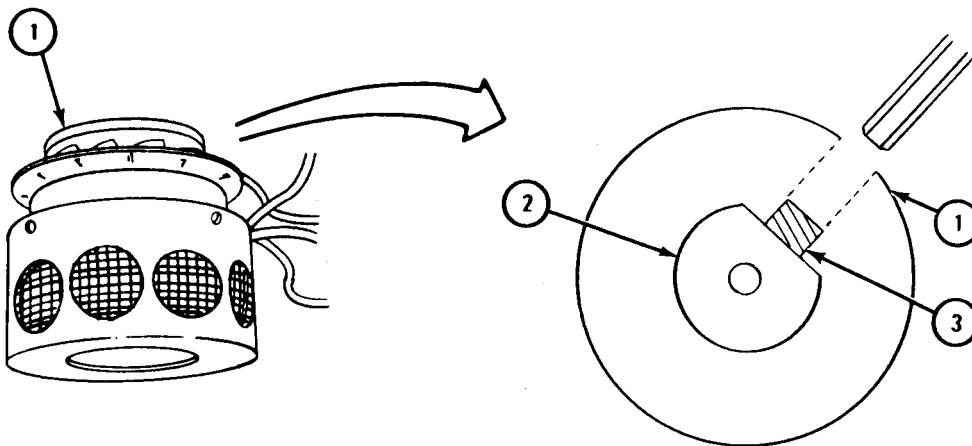

TA 118715

FRAME 3

1. Put on frame (1).
2. Put on two nuts (2).
3. Put fan blade (3) on motor shaft (4) and align setscrew (5) with flat side on motor shaft (4).
4. Tighten setscrew (5).
5. Put cover (6) in place on frame (1).
6. Put on elbow (7).
7. Put in eight screws (8) and nuts (9).

GO TO FRAME 4

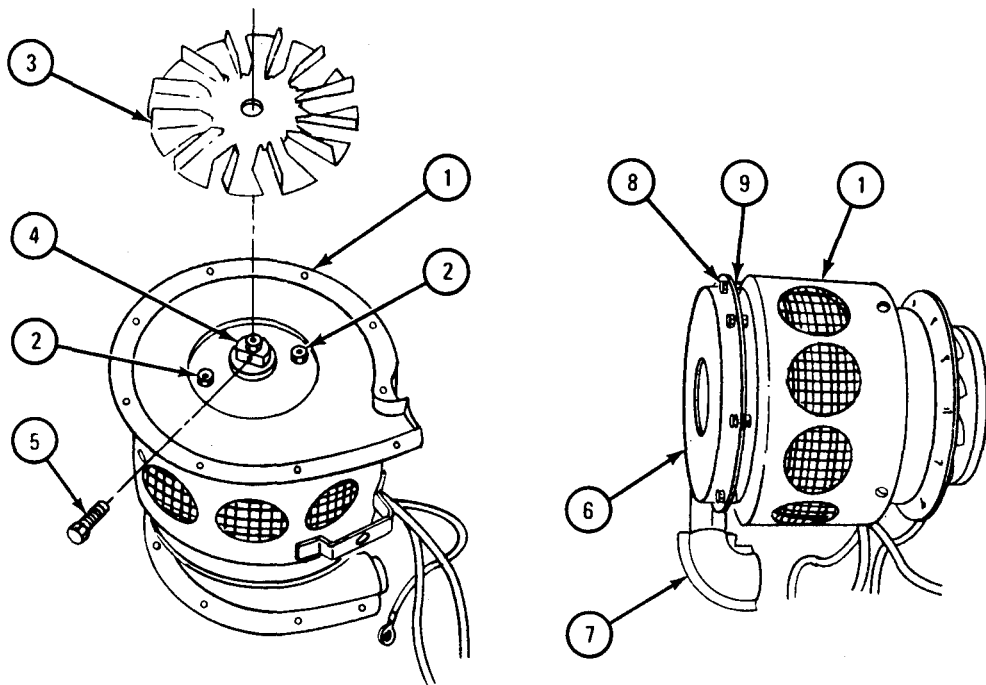

TA 118716

FRAME 4

1. Put cover (1) on end plate (2) and align scribe marks.
2. Put on four clamps (3) and tighten four nuts (4).
3. Put on pipe nipple (5).
4. Put on flame detector switch (6).

GO TO FRAME 5

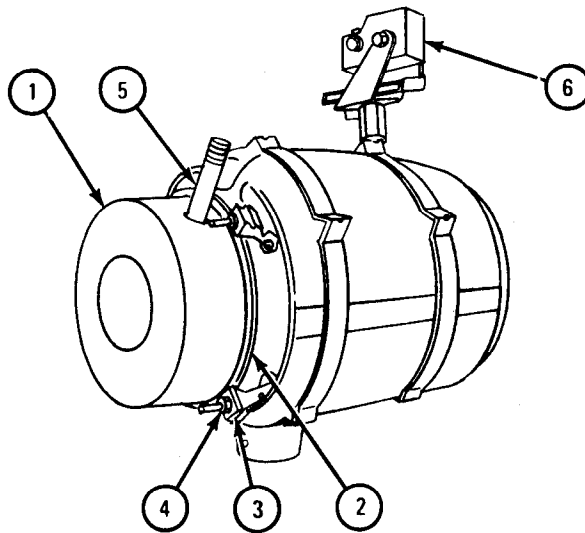

TA 118717

FRAME 5

1. Spread open, but do not bend shell (1). Put chamber (2) in shell.
2. Screw in and tighten three screws (3).

GO TO FRAME 6

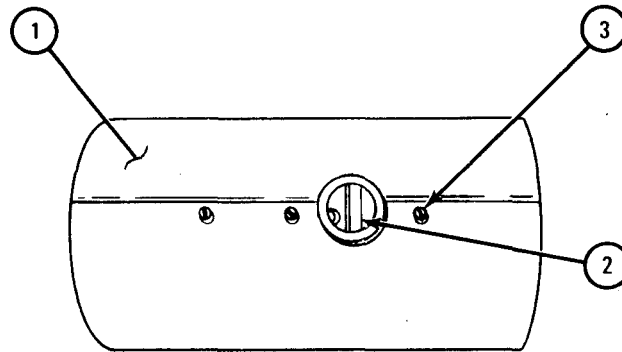

TA 118718

FRAME 6

1. Put on connector plug (1). Screw in and tighten four screws (2).
2. Put on fuel control valve (3). Screw in and tighten three screws (4).
3. Put on bracket (5). Screw in and tighten screw (6).
4. Put on tab (7) and condenser (8). Screw on and tighten nut (9).

GO TO FRAME 7

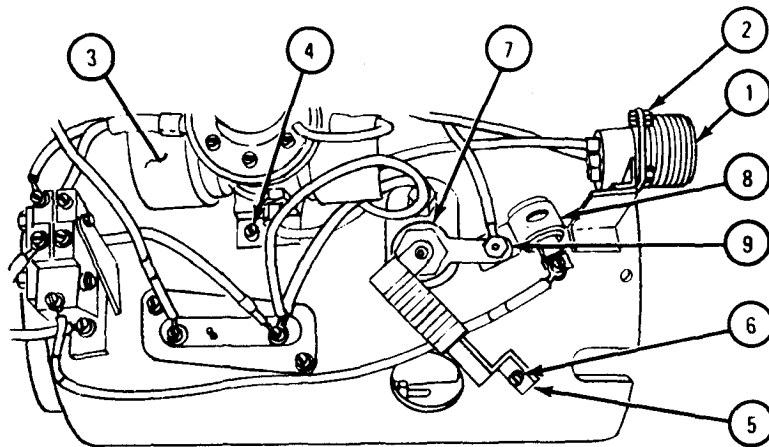

TA 118719

FRAME 7

1. Put on overtemperature switch (1). Screw in and tighten two screws (2).
2. Put on three wires (3). Screw in and tighten three screws (4).
3. Put on wire (5). Screw in and tighten screw (6).
4. Put on four wires (7). Screw on and tighten two nuts (8).

GO TO FRAME 8

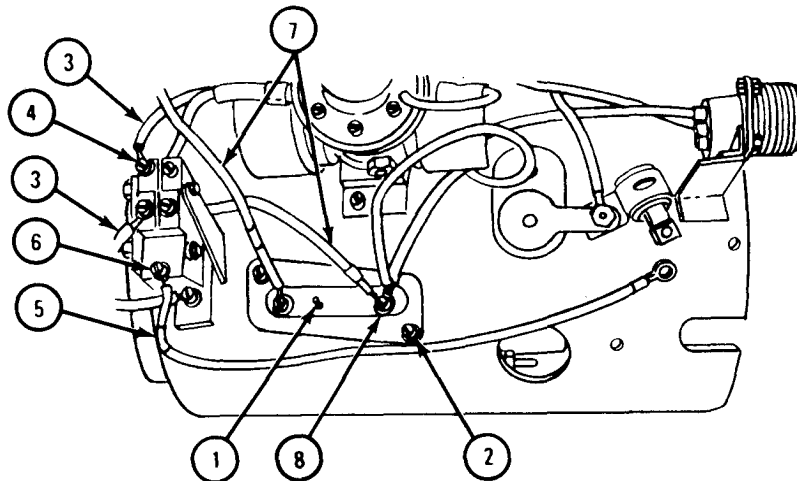

TA 118720

FRAME 8

1. Screw in and tighten glow plug (1).
2. Put on resistor (2). Screw on and tighten nut (3).
3. Put on fuel line (4). Tighten two tube nuts (5).
4. Put on tube (6).
5. Put on wire (7). Screw in and tighten screw (8).

GO TO FRAME 9

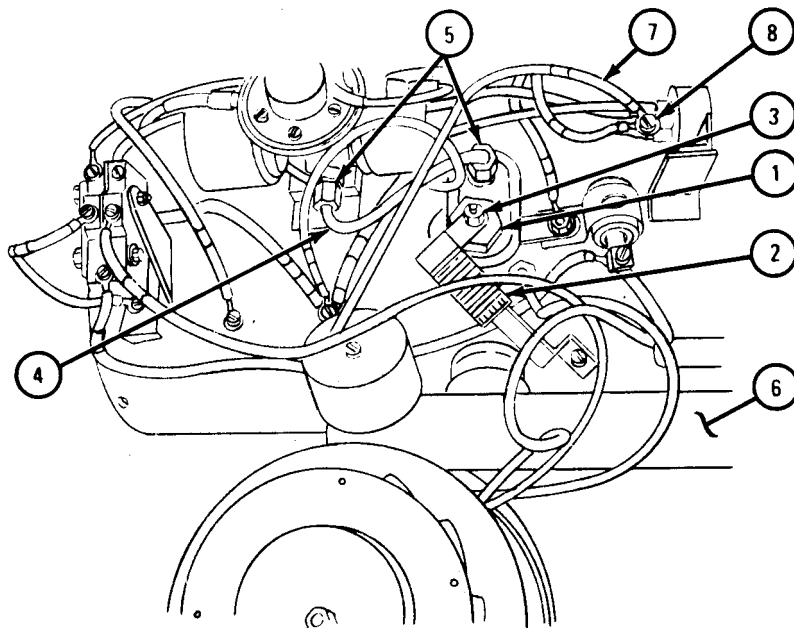

TA 118721

FRAME 9

1. Put on wire (1) of blower assembly (2). Screw in and tighten screw (3).
2. Put on wire (4). Screw on and tighten screw and nut (5).
3. Put on two wires (6 and 7). Screw in and tighten screw (8).

GO TO FRAME 10

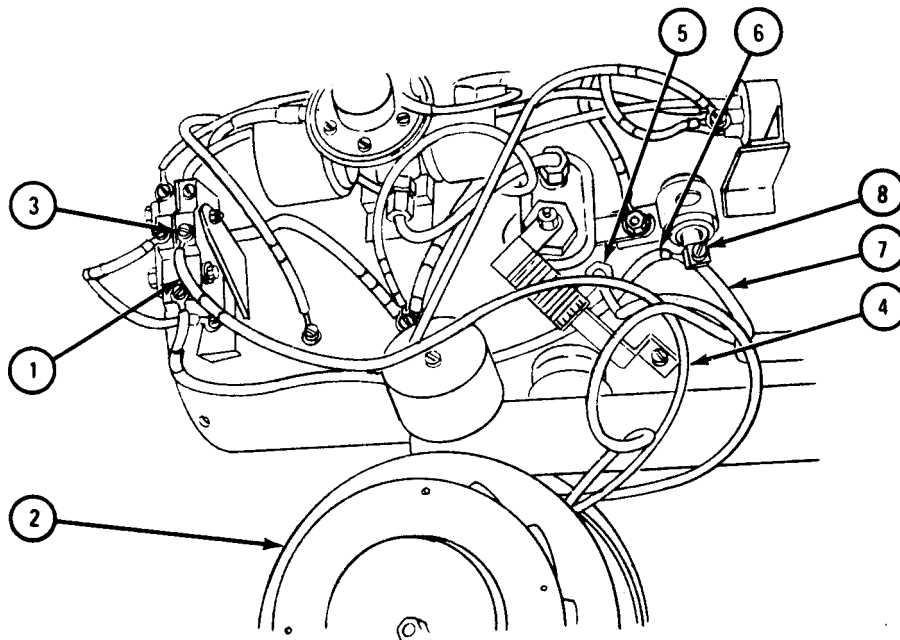

TA 118722

FRAME 10

1. Put outlet duct (1) on body (2).
2. Screw in and tighten four screws (3) and screw (4).
3. Put blower assembly (5) on body (2).
4. Screw in and tighten four screws (6).

END OF TASK

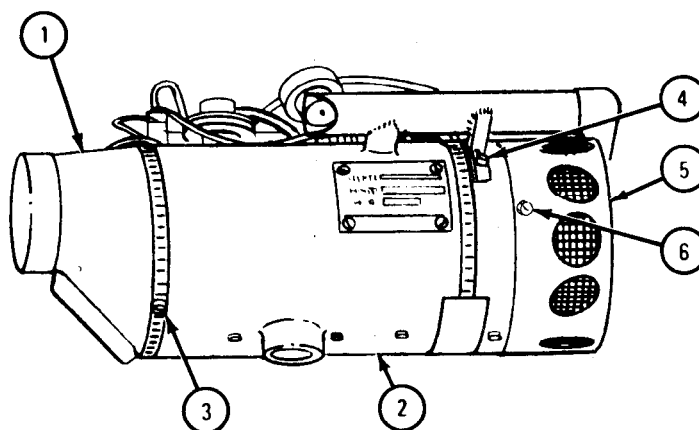

TA 118723

h. Replacement.

FRAME 1

1. Working in engine compartment, put on heater (1). Tighten two clamps (2).
2. Tighten hose clamp (3).
3. Put on cover (4).

NOTE

One of two screws (5) in under cover (4) can be seen through hole in cover.

4. Tighten two screws (5).
5. Screw on and tighten fuel line (6).
6. Screw on wiring harness connector (7).

NOTE

Follow-on Maintenance Action Required:

1. Reconnect battery ground. Refer to TM 9-2320-209-20.
2. Close hood and side panels. Refer to TM 9-2320-209-10.
3. Turn on personnel heater fuel cock. Refer to Operating the Fuel Burning Personnel Heater, TM 9-2320-209-10.

END OF TASK

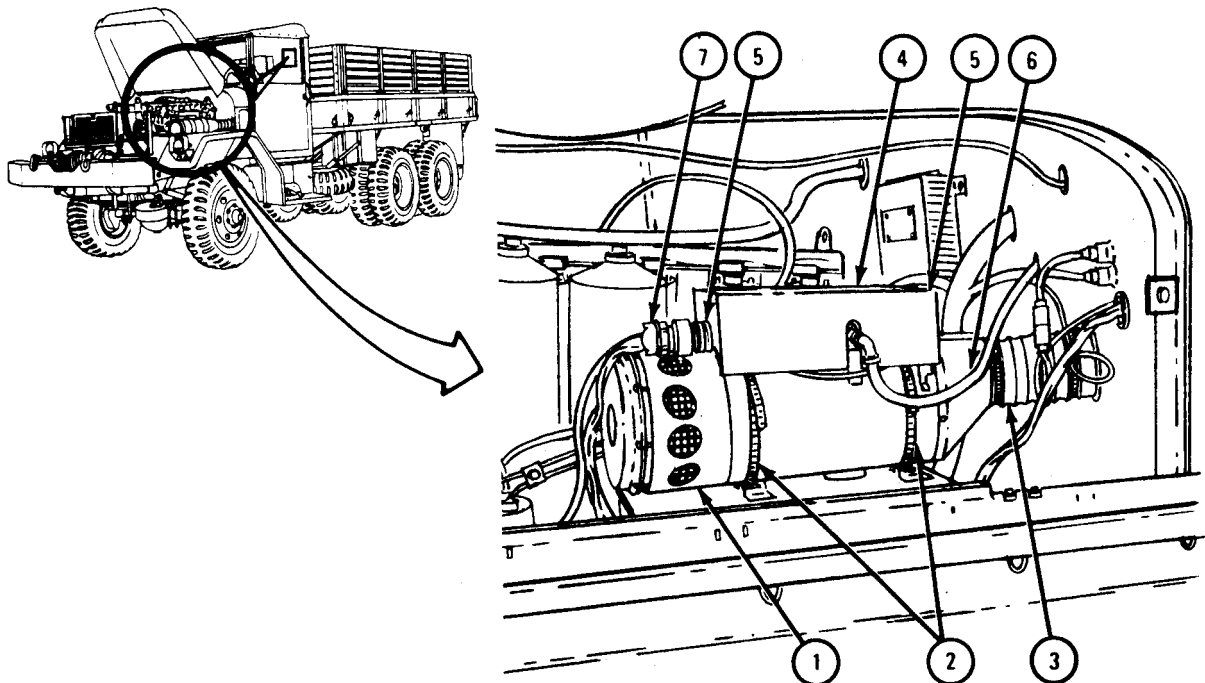

TA 118724

21-10. VAN BODY PERSONNEL HEATER INSTALLATION. Install the van body personnel heater using the instructions that come with the kit.

21-11. VAN BODY PERSONNEL HEATER TEST. Refer to Fuel Burning Personnel Heater Test, para 21-8 for procedure to test van body personnel heater.

21-12. VAN BODY PERSONNEL HEATER OPERATING TEST (TRUCKS M109A2, M109A3, M185A2, AND M185A3).

TOOLS: No special tools required

SUPPLIES: None

PERSONNEL: Two

EQUIPMENT CONDITION: Truck parked, engine off, handbrake set.

WARNING

Dripping fuel is highly flammable. Do not allow smoking, sparks or open flame within 50 feet of work area during this test.

a. Primary Van Body Personnel Heater.

(1) 24-volt test.

(a) Bleeding fuel line.

FRAME 1

- | | | |
|---------------------|----|---|
| Soldiers
A and B | 1. | Open van doors and mount access ladder. Refer to TM 9-2320-209-10. |
| Soldier A | 2. | Turn shut-off cock (1) to ON position. Tell soldier B when ready. |
| Soldier B | 3. | Turn power converter selector switch (2) to 24 VOLT position. |
| | 4. | Loosen line connector (3). |
| | 5. | Turn heater switch (4) to START position. |
| | 6. | Turn heater switch (4) to OFF position when fuel starts to drip from fuel line (5). |
| | 7. | Tighten line connector (3). |

GO TO FRAME 2

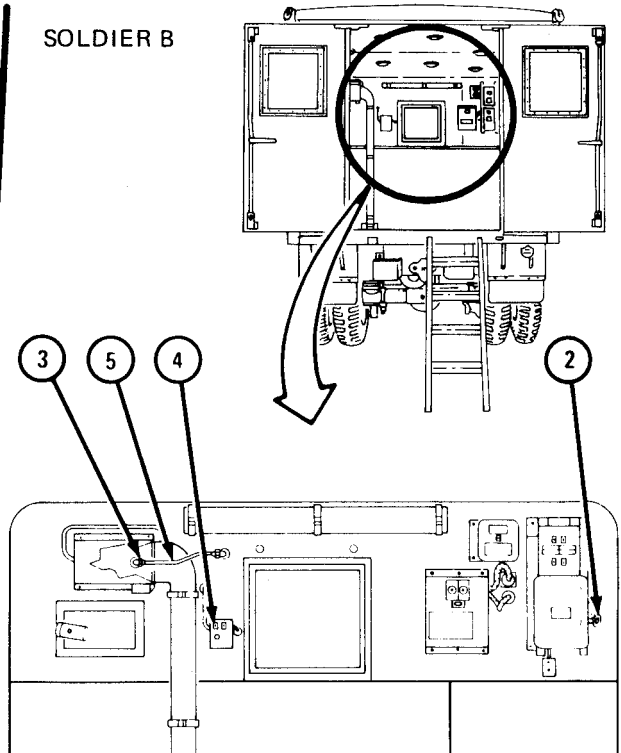
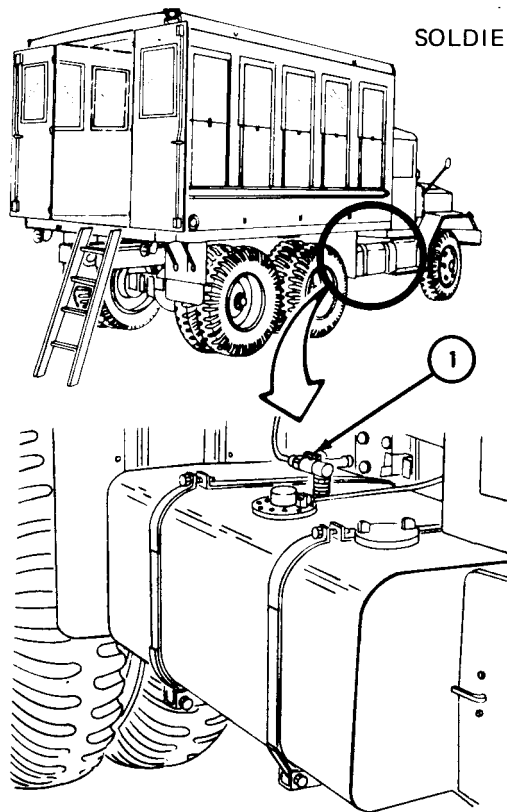

TA 103443

FRAME 2

- Soldier A 1. Loosen line connector (1). Tell soldier B when ready.
- Soldier B 2. Turn heater switch (2) to START position.
- Soldier A 3. Tell soldier B when fuel starts to drip from fuel line (3).
- Soldier B 4. Turn heater switch (2) to OFF position.
- Soldier A 5. Tighten line connector (1). If fuel does not drip from fuel line, refer to para 21-13 for repair.

END OF TASK

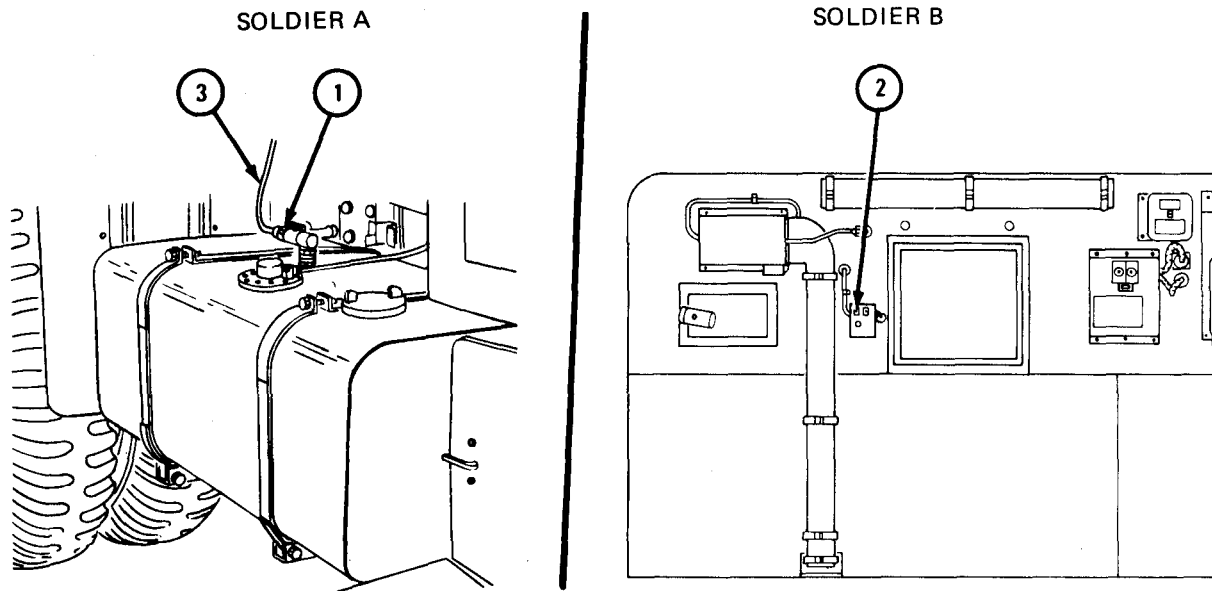

TA 103444

(b) Starting and stopping heater.

FRAME 1

1. Turn heater HI-LO switch (1) to HI position.
2. Turn heater switch (2) to START position. Blower should start at once and heater should ignite within 1 minute, with warm air in 2 to 3 minutes.
3. Turn HI-LO switch (1) to LO position. Burning should decrease and heat should be less than at HI position. If heater does not work properly, refer to para 21-13 for repair.

GO TO FRAME 2

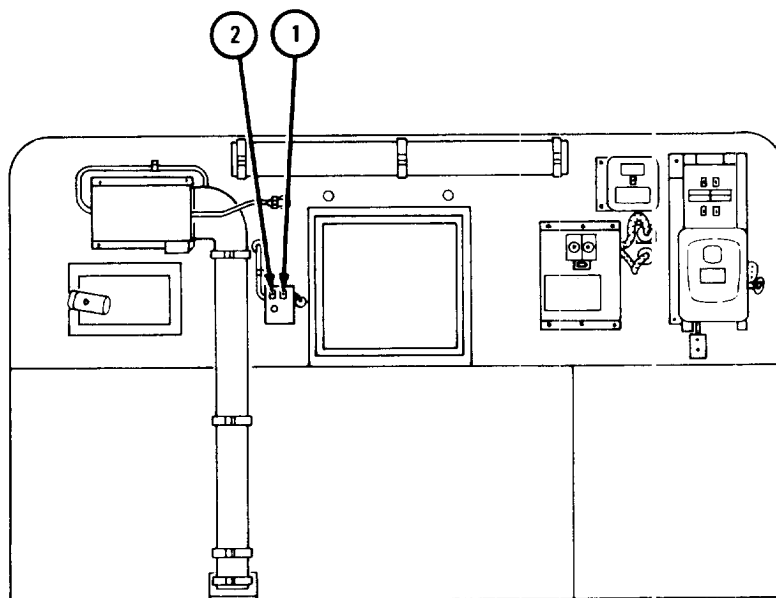

TA 103445

FRAME 2

Soldier A 1. Turn heater switch (1) to OFF position. Burning should stop within a few seconds. Blower will continue to run for 2 or 3 minutes. If heater does not work properly, refer to para 21-13 for repair.

Soldier B 2. Turn shut-off cock (2) to OFF position.

END OF TASK

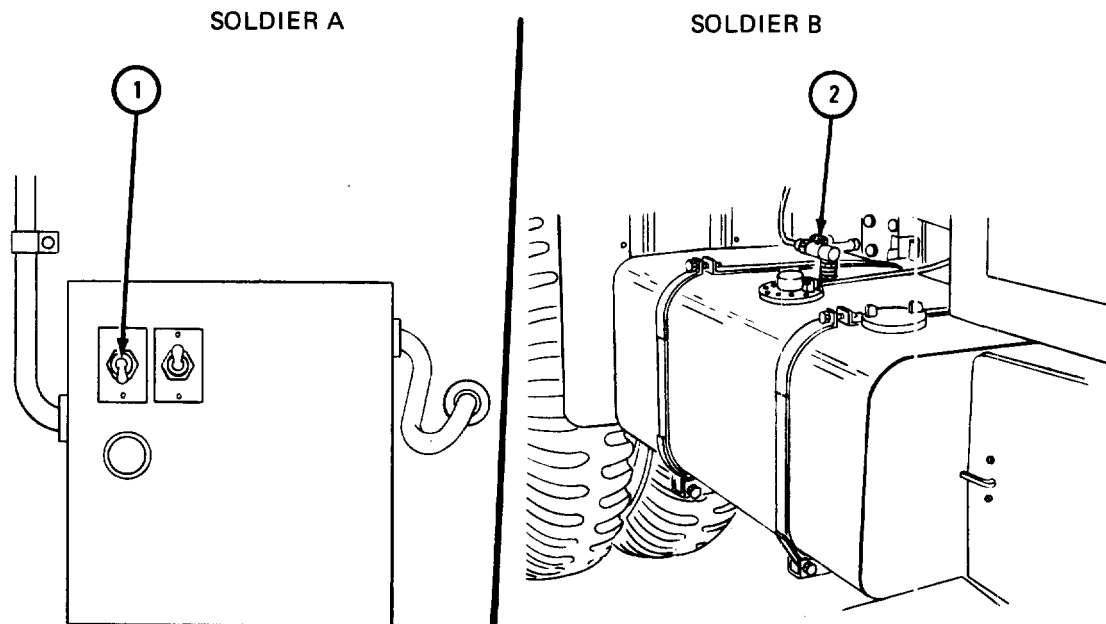

TA 103446

- (2) 115-volt test.
 - (a) Bleeding fuel lines.

FRAME 1

1. Connect 115-volt line. Refer to TM 9-2320-209--10.
- Soldier A 2. Turn shut-off cock (1) to ON position. Tell soldier B when ready.
- Soldier B 3. Turn power converter selector switch (2) to 115-VOLT position.
4. Loosen line connector (3).
5. Turn heater switch (4) to START positior..
6. When fuel starts to drip from fuel line (5) turn heater switch (4) to OFF position.
7. Tighten line connector (3).

GO TO FRAME 2

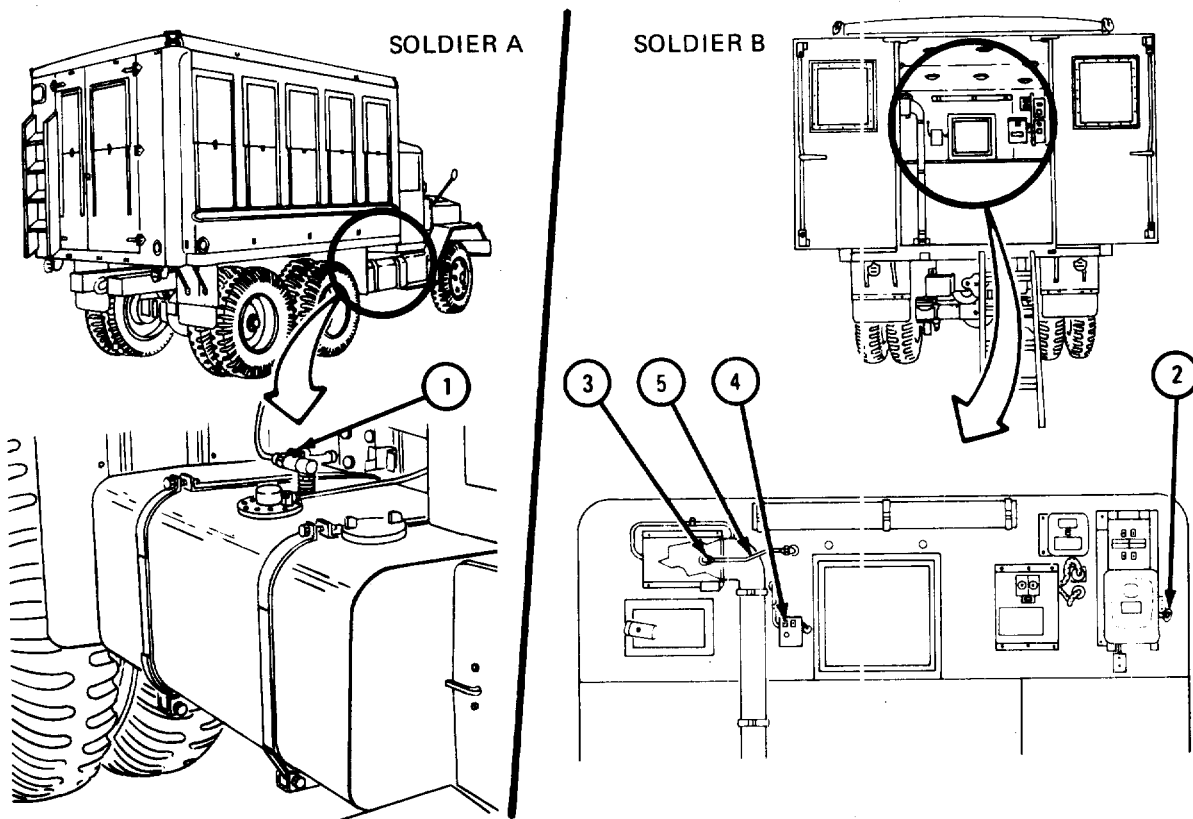

TA 103447

FRAME 2

- Soldier A 1. Loosen line connector (1). Tell soldier B when ready,
Soldier B 2. Turn heater switch (2) to START position.
Soldier A 3. Tell soldier B when fuel starts to drip from fuel line (3) .
Soldier B 4. Turn heater switch (2) to OFF position.
5. Tighten line connector (1) . If fuel does, not drip from fuel line,
refer to para 21-13 for repair.

END OF TASK

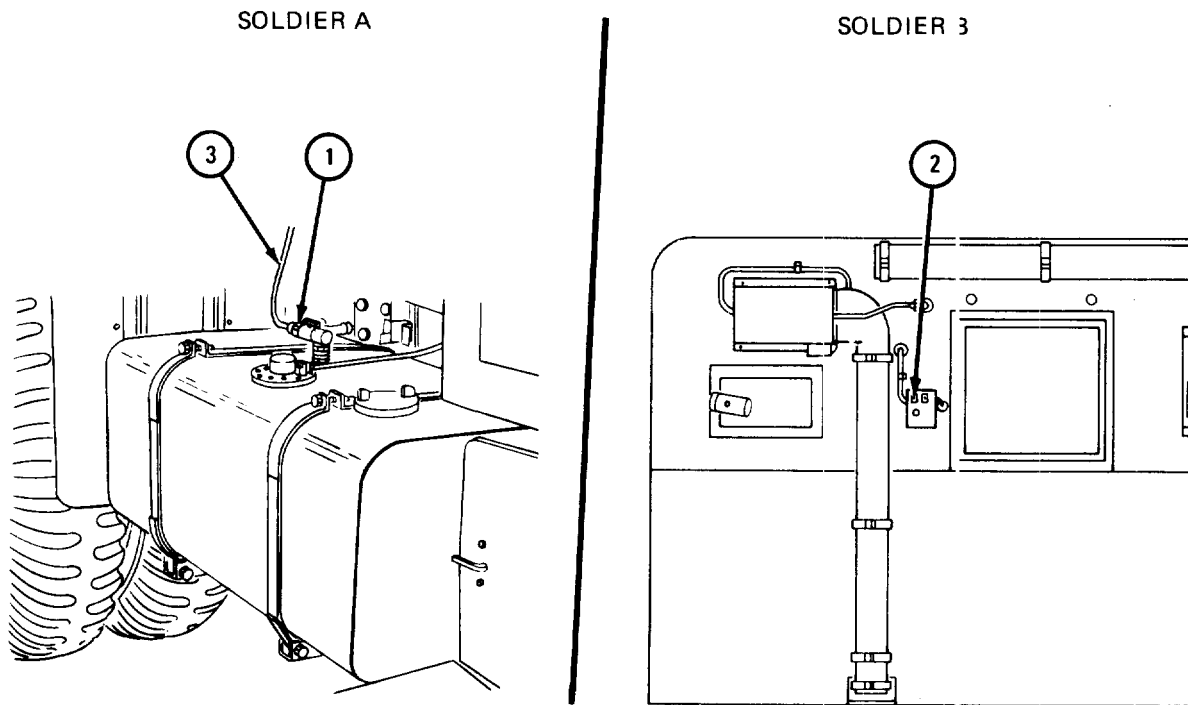

TA 103448

(b) Starting and stopping heater.

FRAME 1

1. Turn heater HI-LO switch (1) to HI position.
2. Turn heater switch (2) to START position. Blower should start at once and heater should ignite within 1 minute, with warm air in 2 to 3 minutes.
3. Turn HI-LO switch (1) to LO position. Burning should decrease and heat should be less than at HI position. If heater does not work properly, refer to para 21-13 for repair.

GO TO FRAME 2

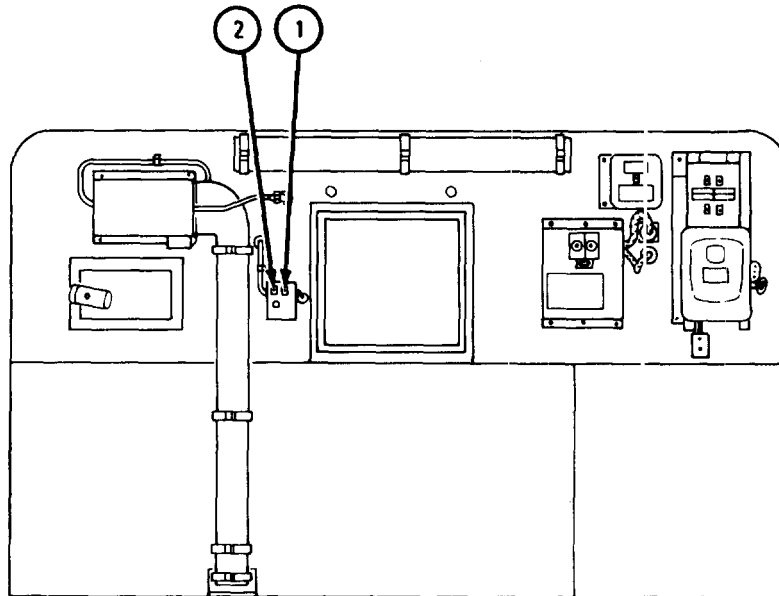

TA 103445

FRAME 2

Soldier A 1. Turn heater switch (1) to OFF position. Burning should stop within a few seconds. Blower will continue to run for 2 or 3 minutes. If heater does not work properly, refer to para 21-13 for repair.

Soldier B 2. Turn shut-off cock (2) to OFF position.
3. Disconnect 115 volt line. Refer to TM 9-2320-209-10.

Soldiers A and B 4. Close van doors and mount access ladder. Refer to TM 9-2320-209-10.

END OF TASK

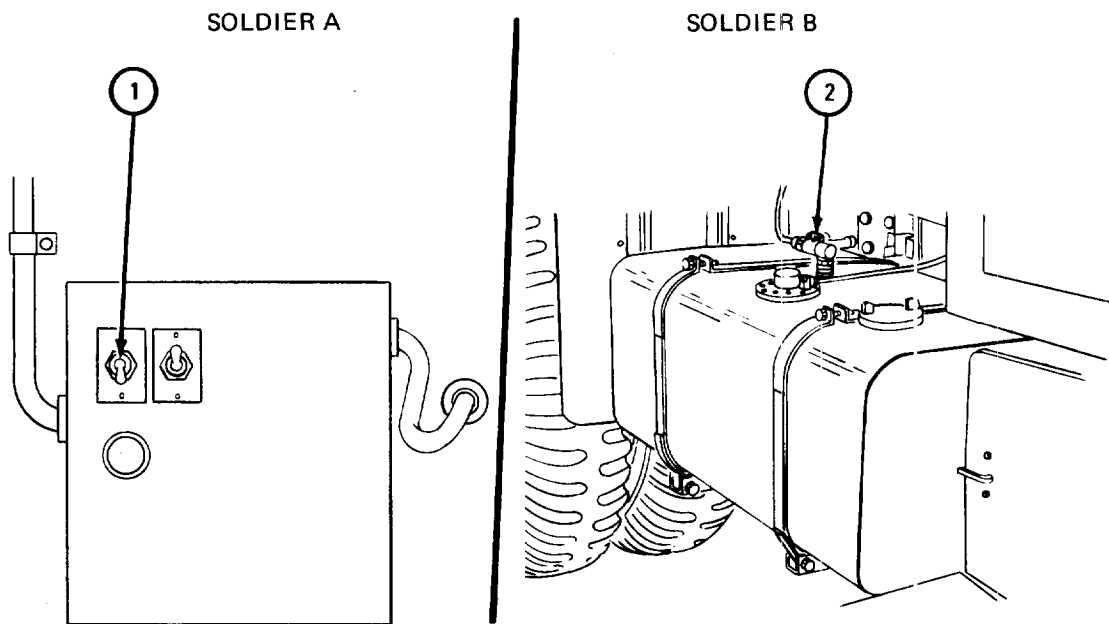

TA 103446

b. Secondary Van Body Personnel Heater.

(1) 24-volt test.

(a) Bleeding fuel line.

FRAME 1

- Soldiers A and B 1. Open van doors and mount access ladder. Refer to TM 9-2320-209-10.
- Soldier A 2. Turn shut-off cock (1) to ON position. Tell soldier B when ready.
- Solder B 3. Turn power converter selector switch (2) to 24-volt position.
4. Loosen line connector (3).
5. Turn heater switch (4) to START position.
6. Turn heater switch (4) to OFF position when fuel starts to drip from fuel line (5) .
7. Tighten line connector (3) .

GO TO FRAME 2

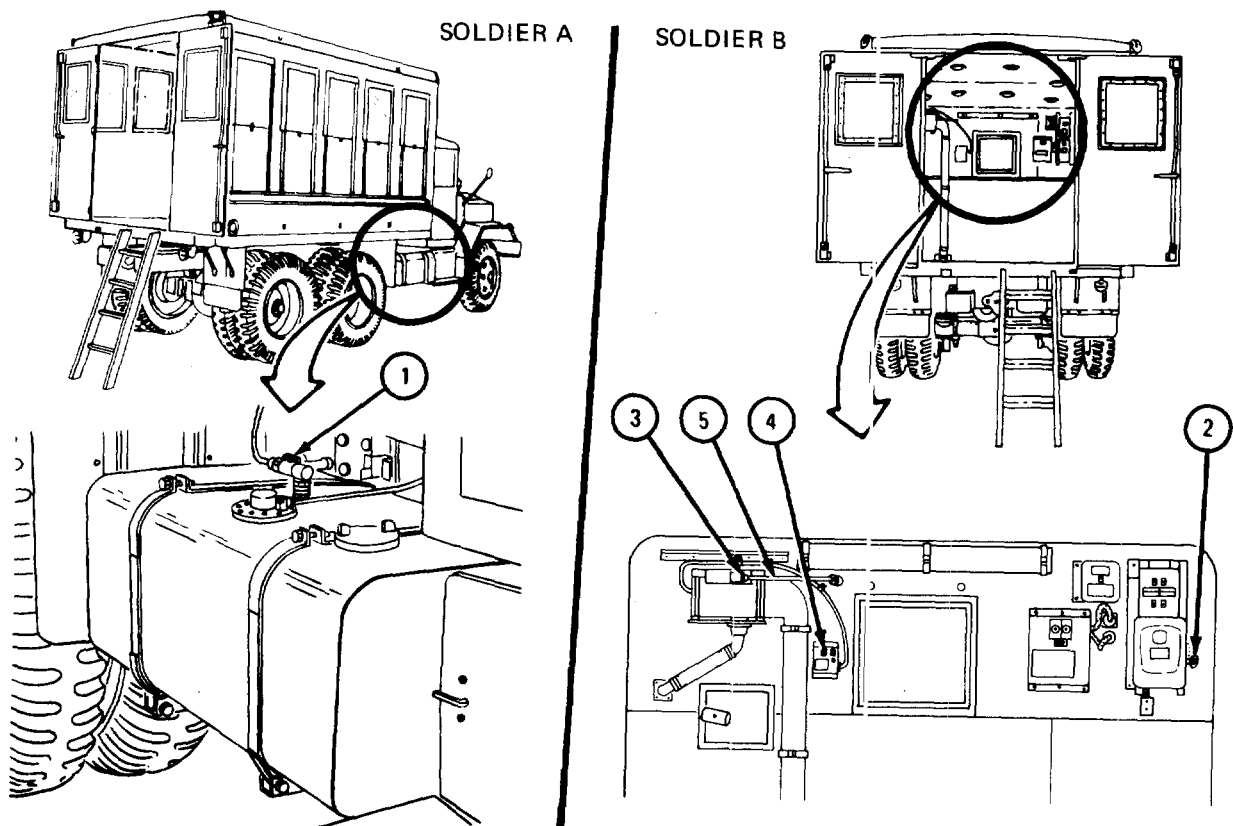

TA 103449

FRAME 2

- Soldier A 1. Loosen line connector (1). Tell soldier B when ready.
Soldier B 2. Turn heater switch (2) to START position.
Soldier A 3. Tell soldier B when fuel starts to drip from fuel line (3).
Soldier B 4. Turn heater switch (2) to OFF position.
Soldier A 5. Tighten line connector (1). If fuel does not drip from fuel line, refer to para 21-13 for repair.

END OF TASK

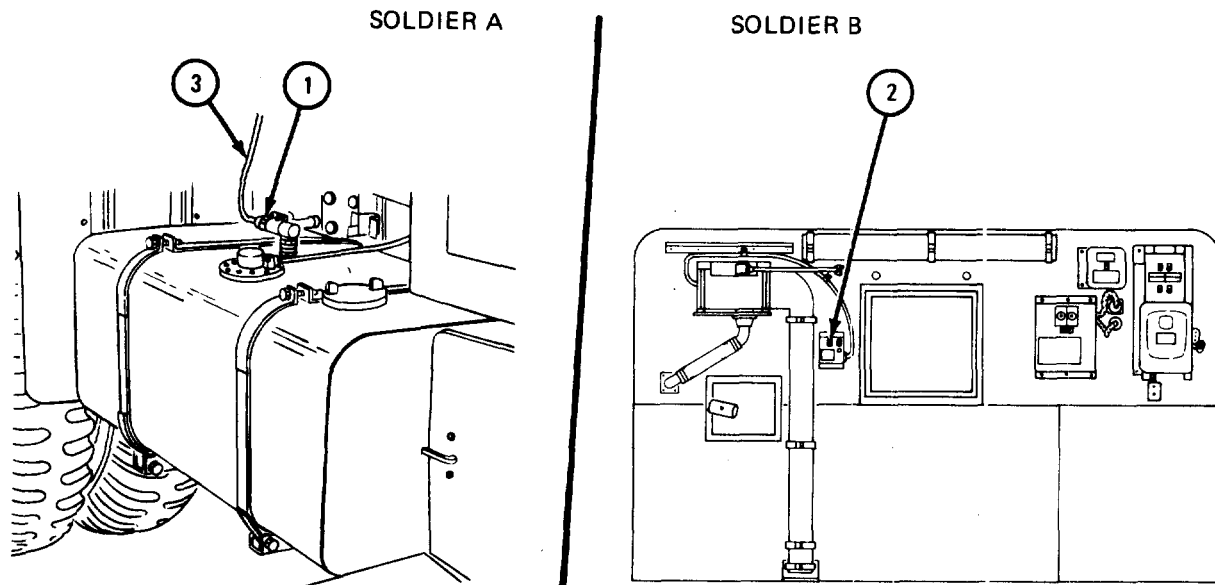

TA 103450

(b) Starting and stopping heater.

FRAME 1

1. Turn heater HI-LO switch (1) to HI position.
2. Turn heater switch (2) to START position. Blower should start at once and heater should ignite within 1 minute, with warm air in 2 to 3 minutes.
3. Turn HI-LO switch (1) to LO position. Burning should decrease and heat should be less than at HI position. If heater does not work properly, refer to para 21-13 for repair.

GO TO FRAME 2

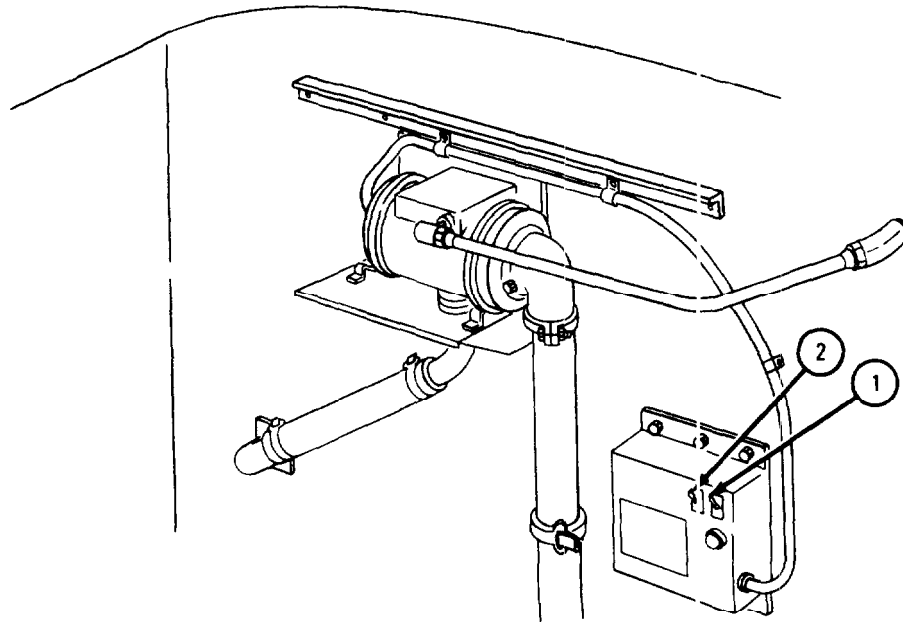

TA 103451

FRAME 2

Soldier A 1. Turn heater switch (1) to OFF position. Burning should stop within a few seconds. Blower will continue to run for 2 or 3 minutes. If heater does not work properly, refer to para 21-13.

Soldier B 2. Turn shut-off cock (2) to OFF position.

END OF TASK

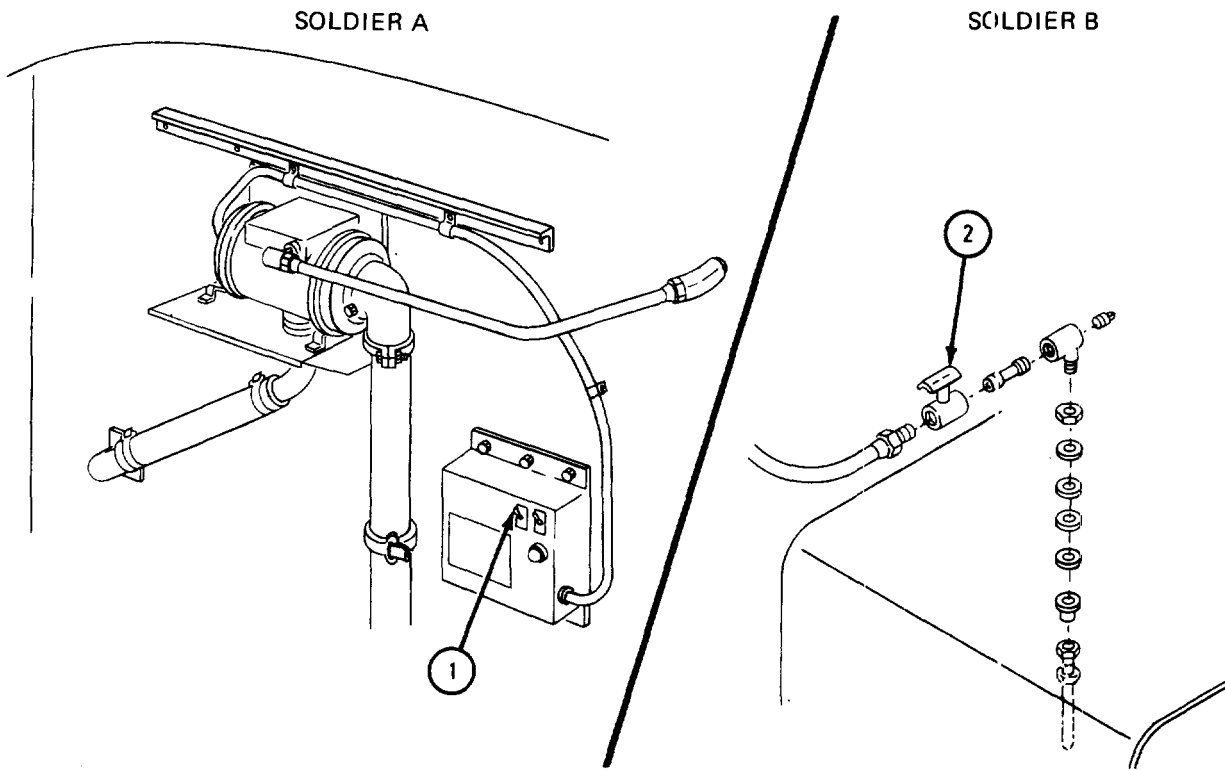

TA 103452

(2) 115-volt test.

(a) Bleeding fuel lines.

1. Connect 115-volt line. Refer to TM 9-2320-209-10.
- Soldier A 2. Turn shut-off cock (1) to ON position. Tell soldier B when ready.
- Soldier B 3. Turn power converter selector switch (2) to 115-VOLT position.
4. Loosen line connector (3).
5. Turn heater switch (4) to START position.
6. Turn heater switch (4) to OFF position when fuel starts to drip from fuel line (5) .
7. Tighten line connector (3) .

GO TO FRAME 2

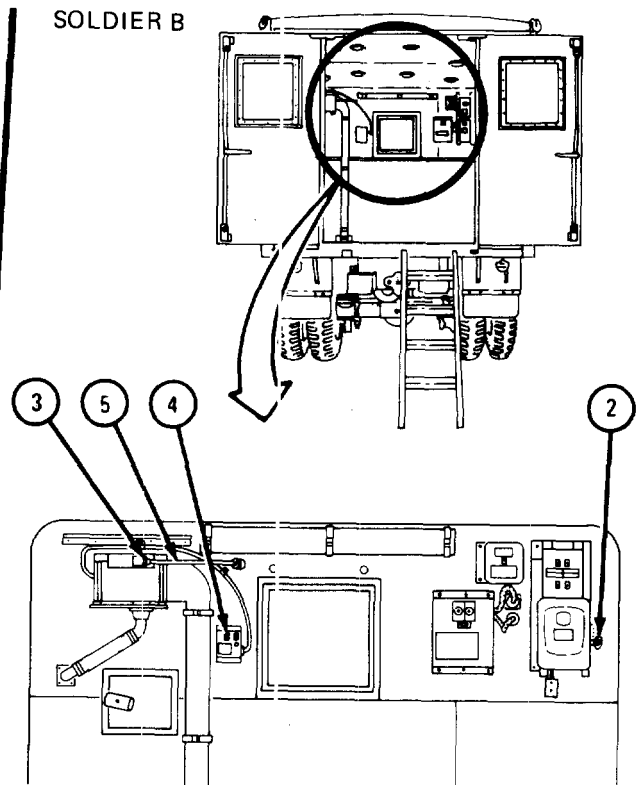
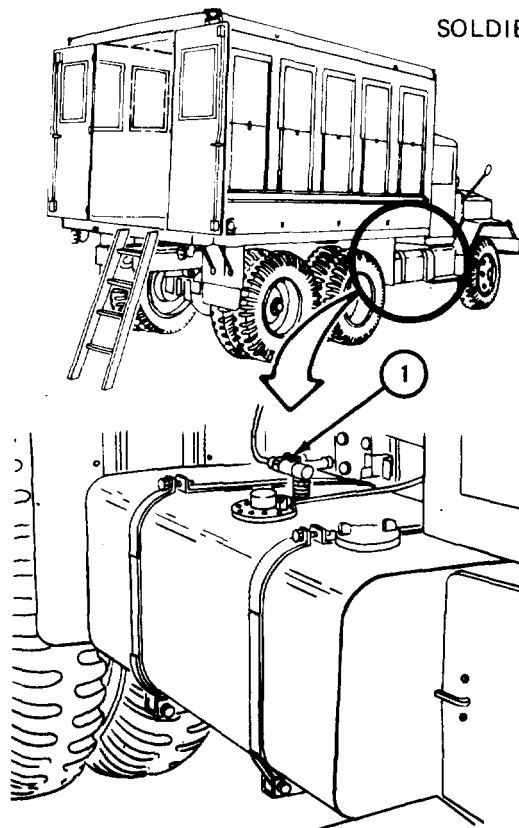

TA 103449

FRAME 2

- Soldier A 1. Loosen line connector (1). Tell soldier B when ready.
- Soldier B 2. Turn heater switch (2) to START position.
- Soldier A 3. Tell soldier B when fuel starts to drip from fuel line (3).
- Soldier B 4. Turn heater switch (2) to OFF position.
5. Tighten line connector (1) . If fuel does not drill from fuel line, refer to para 21-13 for repair.

END OF TASK

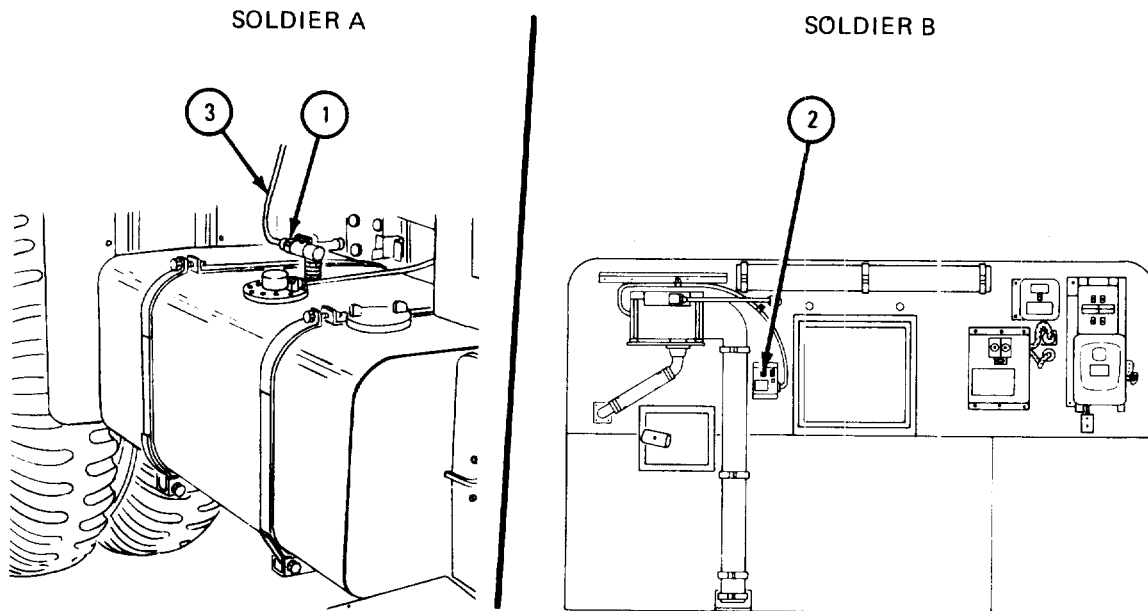

TA 103453

(b) Starting and stopping heater.

FRAME 1

1. Turn heater HI-LO switch (1) to HI position.
2. Turn heater switch (2) to START position. Blower should start at once and heater should ignite within 1 minute, with warm air in 2 to 3 minutes.
3. Turn HI-LO switch (1) to LO position. Burning should decrease and heat should be less than at HI position. If heater does not work properly, refer to para 21-13 for repair.

GO TO FRAME 2

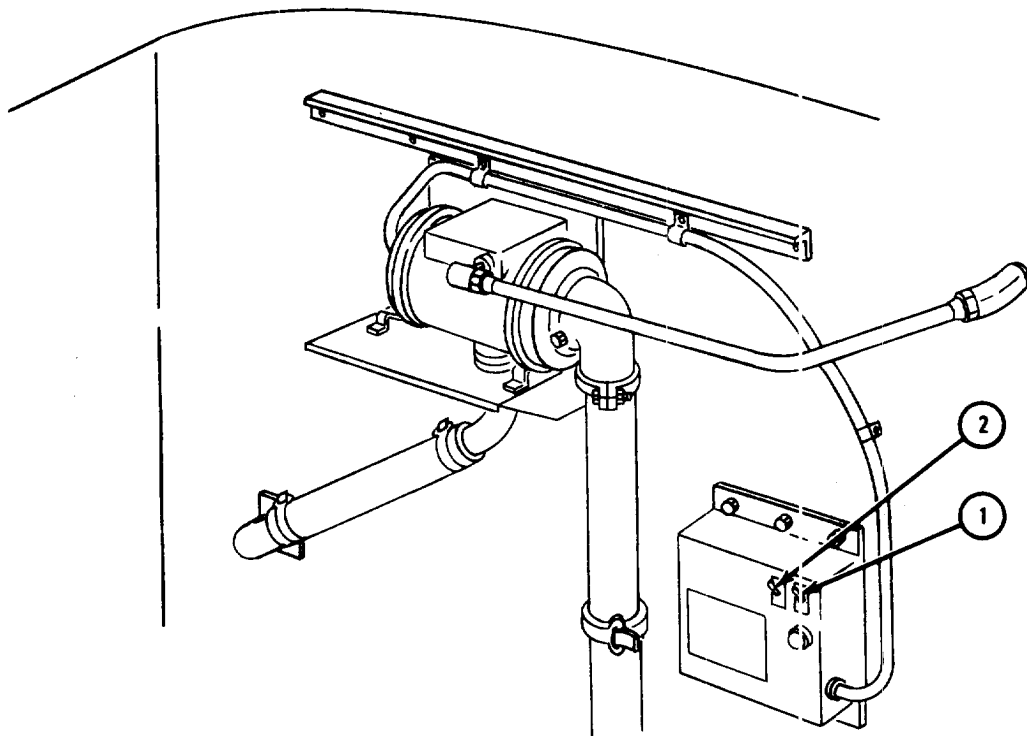

TA 103451

FRAME 2

Soldier A 1. Turn heater switch (1) to OFF position. Burning should stop within a few seconds. Blower will continue to run for 2 or 3 minutes. If heater does not work properly, refer to para 21-13 for repair.

Soldier B 2. Turn shut-off cock (2) to OFF position.
3. Disconnect 115-volt line. Refer to TM 9-2320-209-10.

Soldiers A and B 4. Close van doors and mount access ladder. Refer to TM 9-2320-209-10.

END OF TASK

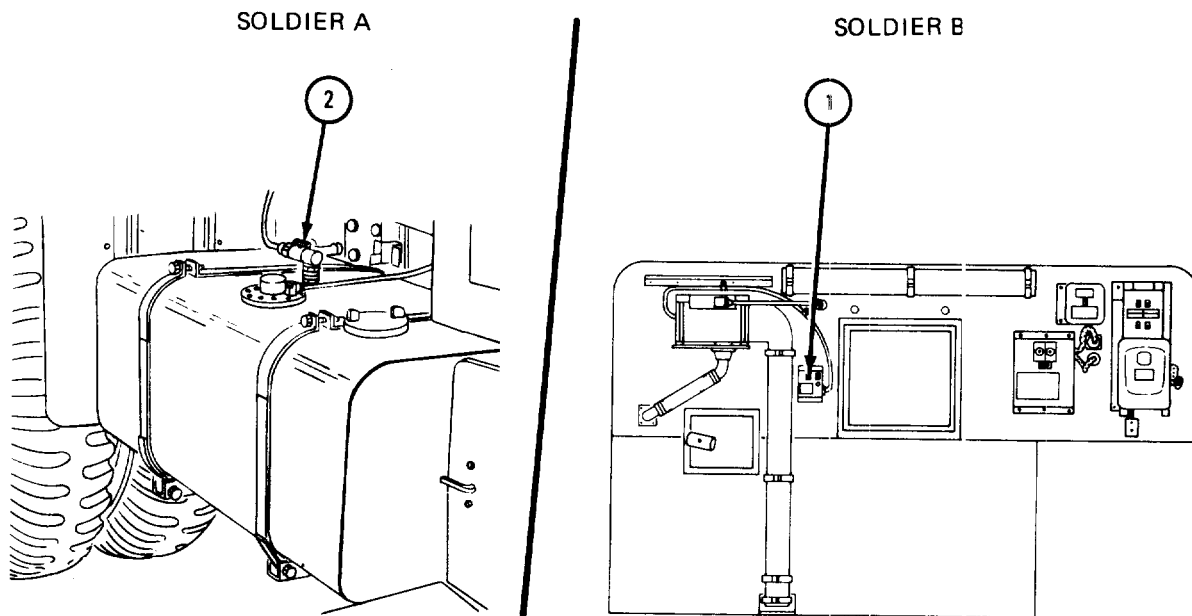

TA 103455

21-13. VAN BODY PERSONNEL HEATER REPAIR. Refer to Fuel Burning Personnel Heater Removal, Repair, and Replacement, para 21-9, for procedure to repair van body personnel heater.

21-14. VAN BODY SECONDARY HEATER REPAIR. Refer to Fuel Burning Personnel Heater Removal, Repair, and Replacement, para 21-9, for procedure to repair van body secondary heater.

21-15. HARD TOP CLOSURE KIT INSTALLATION.

TOOLS : No special tools required

SUPPLIES : Hard top closure kit, NSN 2540-00-570-1443

PERSONNEL: One

EQUIPMENT CONDITION: Truck parked, engine off, handbrake set.

Preliminary Procedures. Remove cab top paulin. Refer to Bow and Tarp Kits Installation and Removal, TM 9-2320-209-10.

b. Installation.

FRAME 1

1. Take out two buttons (1).
2. Find and mark center of top of windshield frame (2) .
3. Mark points (3 and 4) 21 7/8 inches from center of windshield frame (2).
4. Drill 7/16-inch hole at points (3 and 4).

NOTE

No other work on truck is necessary. Installation can be finished by following replacement procedure for cab hard top . Refer to para 21-6.

END OF TASK

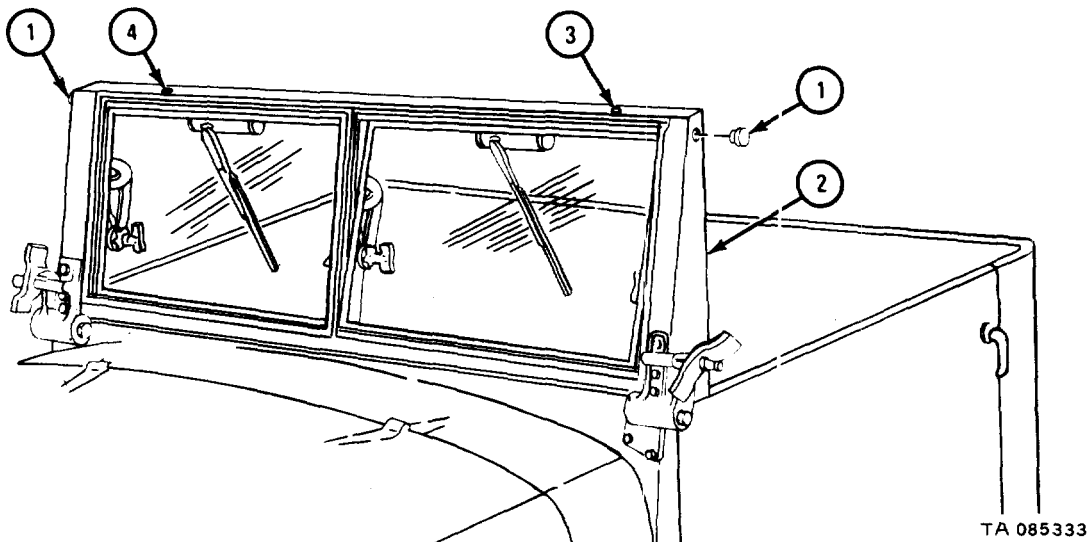

TA 085333

21-16. HARD TOP CLOSURE KIT REMOVAL, REPAIR, AND REPLACEMENT.

TOOLS : No special tools required

SUPPLIES : Adhesive, type II, MIL-A-5092
Back panel seal
Rear roof panel seal
Front roof panel seal

PERSONNEL: Two

EQUIPMENT CONDITION : Truck parked, engine off, handbrake set.

a. Removal.

FRAME 1

1. Take out two screws (1) and washers (2) , one on each side of roof panel (3) .
2. Take out capscrew (4) , clamp (5) , and nut (6) , one on each side of roof panel (3).
3. Take out 14 screws (7) , 14 nuts (8) , and 28 washers (9).

Soldiers 4. Lift off roof panel (3).
A and B

GO TO FRAME 2

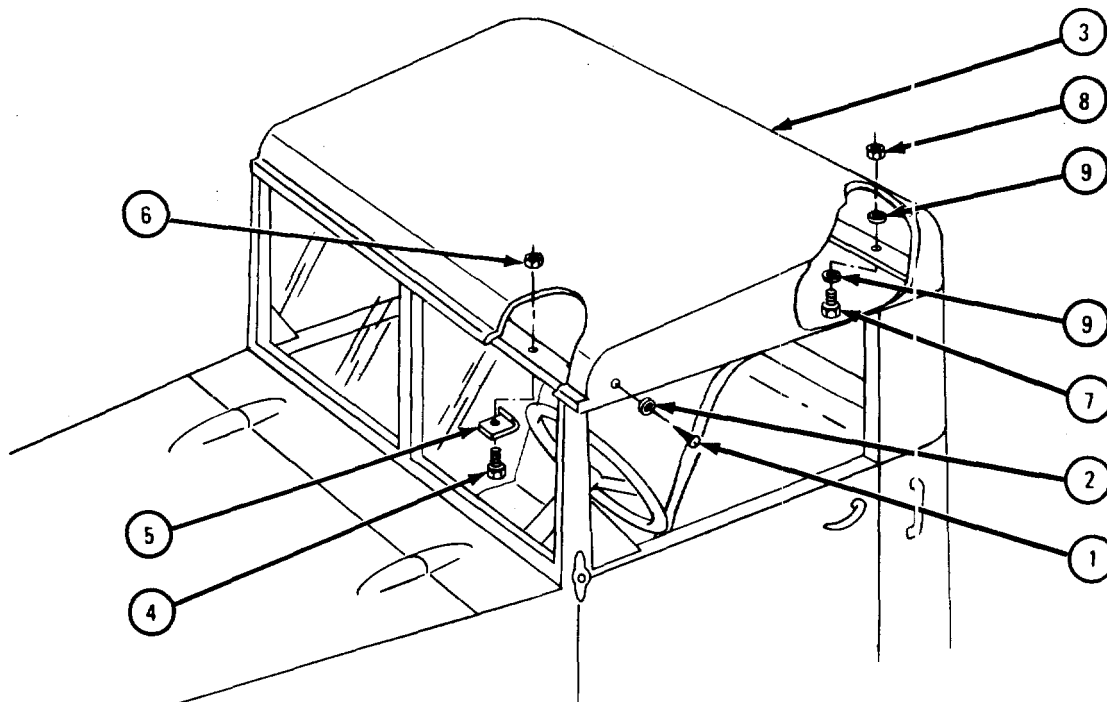

TA 102676

FRAME 2

1. Take off and throw away rear roof panel seal (1).
2. Take out two screws (2) and two retainers (3) .
3. Take out 14 capscrews (4), 14 nuts (5), and 14 washers (6).
- Soldiers A and B 4. Take off back panel (7) .
5. Take off and throw away back seal (8) .

END OF TASK

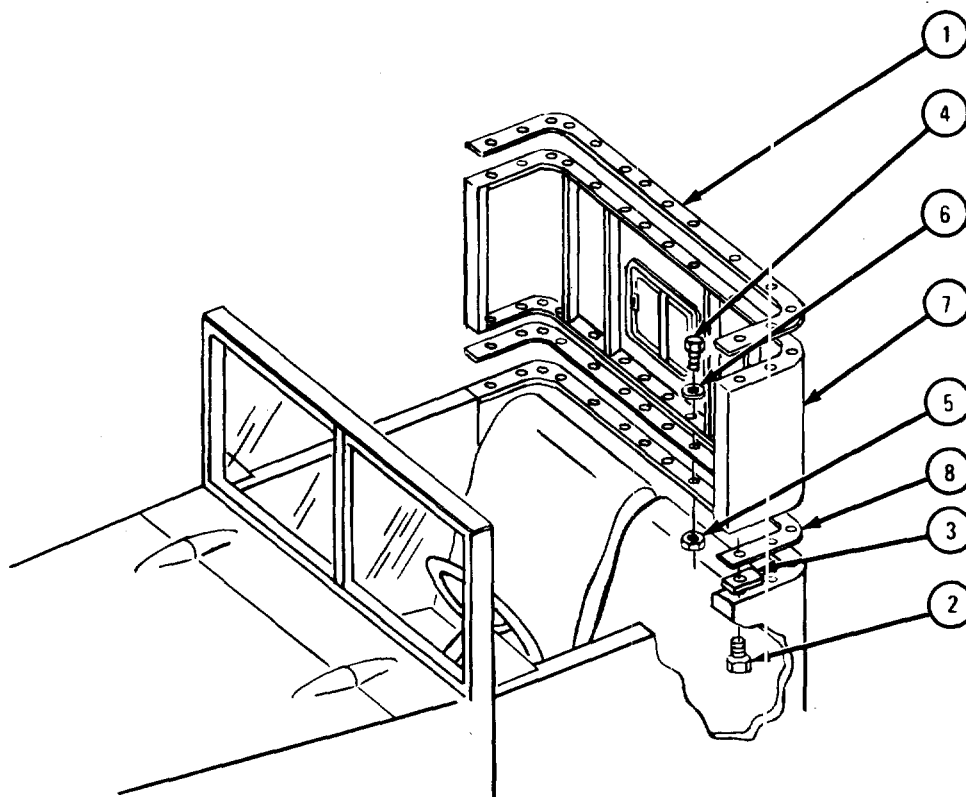

TA 102677

b. Disassembly.

FRAME 1

- Soldier A 1. Working from outside back panel (1) , hold eight screws (2).
- Soldier B 2. Working inside back panel (1) , take off eight nuts (3) and eight washers (4). Tell soldier A to take off frame cap (5) and eight screws (2).
- Soldier A 3. Working outside back panel (1) , hold 14 screws (6) .
- Soldier B 4. Working inside back panel (1) , take off 14 nuts (7) and 14 washers (8). Tell soldier A to take out glass frame assembly (9) and 14 screws (6).

3 TO FRAME 2

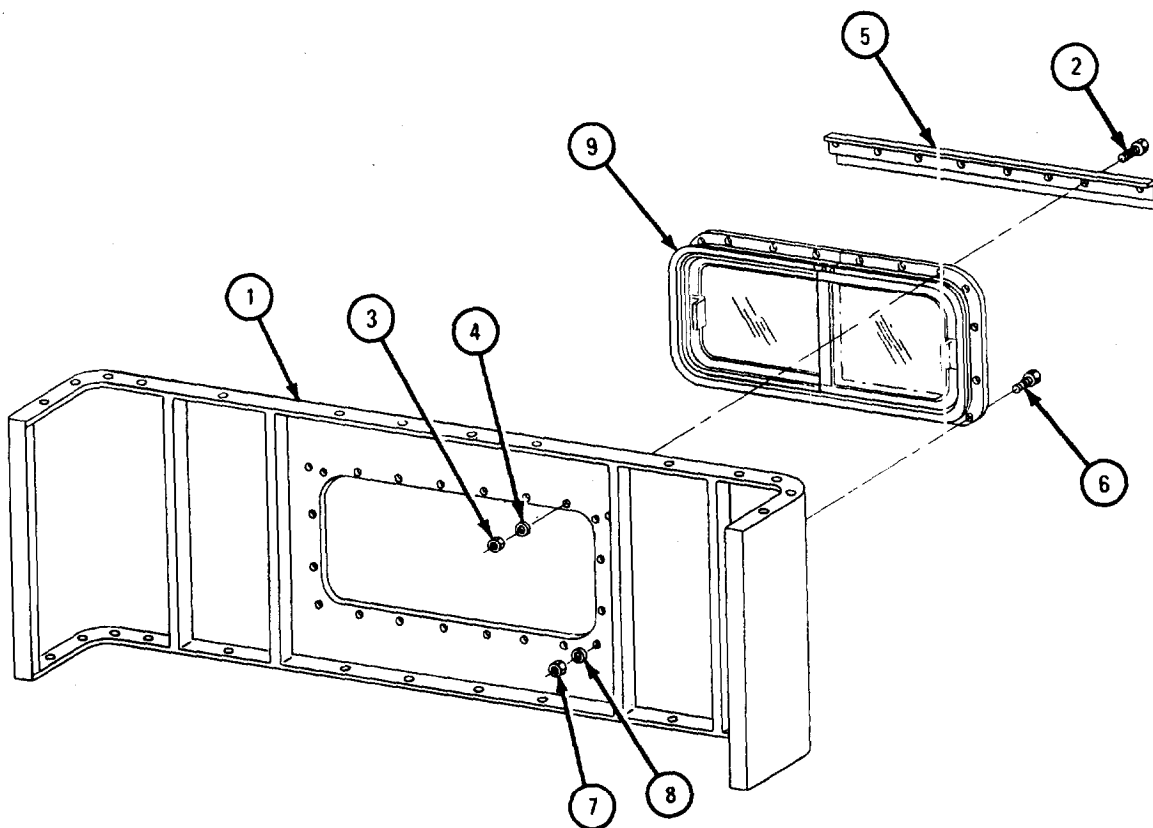

TA 102678

FRAME 2

1. Takeout five screws (1) and nuts (2). Take off and throw away front roof panel seal (3).

END OF TASK

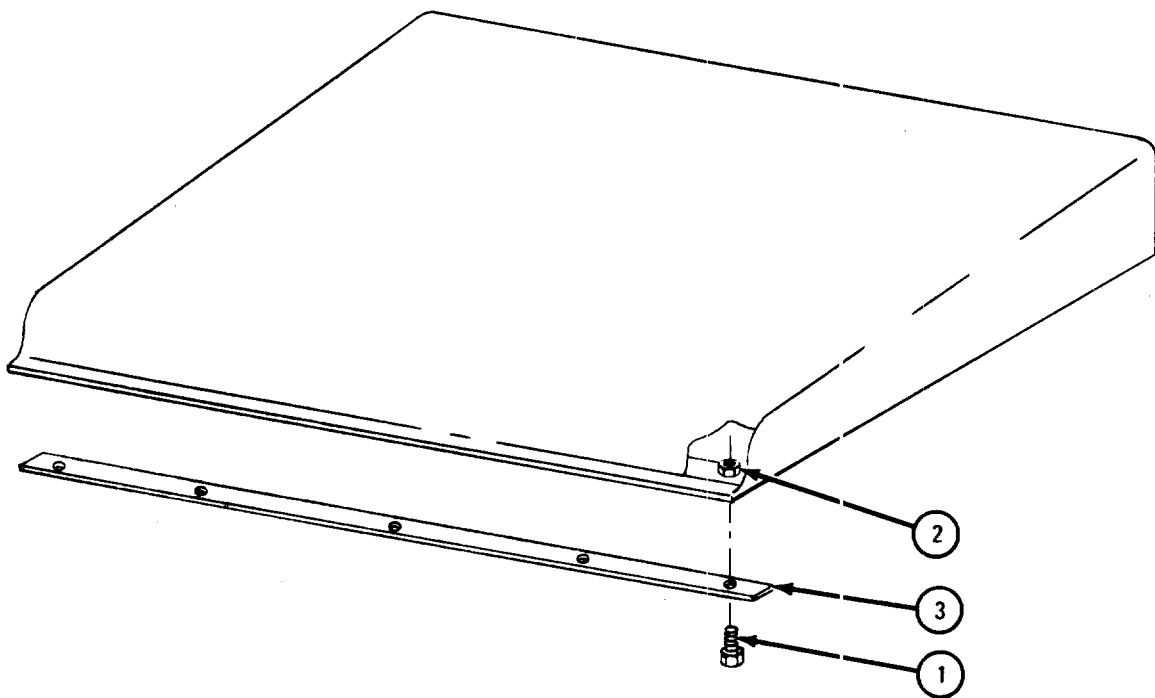

There are no special cleaning procedures needed. Refer to cleaning procedures given in Part 1, para 1-3.

d. Inspection and Repair.

1. Check that all threaded parts are not damaged. If threads are damaged, get new parts.
2. Check that roof panel (1) and back panel (2) are not dented or cracked. If panels are damaged, refer to FM 43-2.
3. If glass frame (3) is damaged in any way, get a new one.

END OF TASK

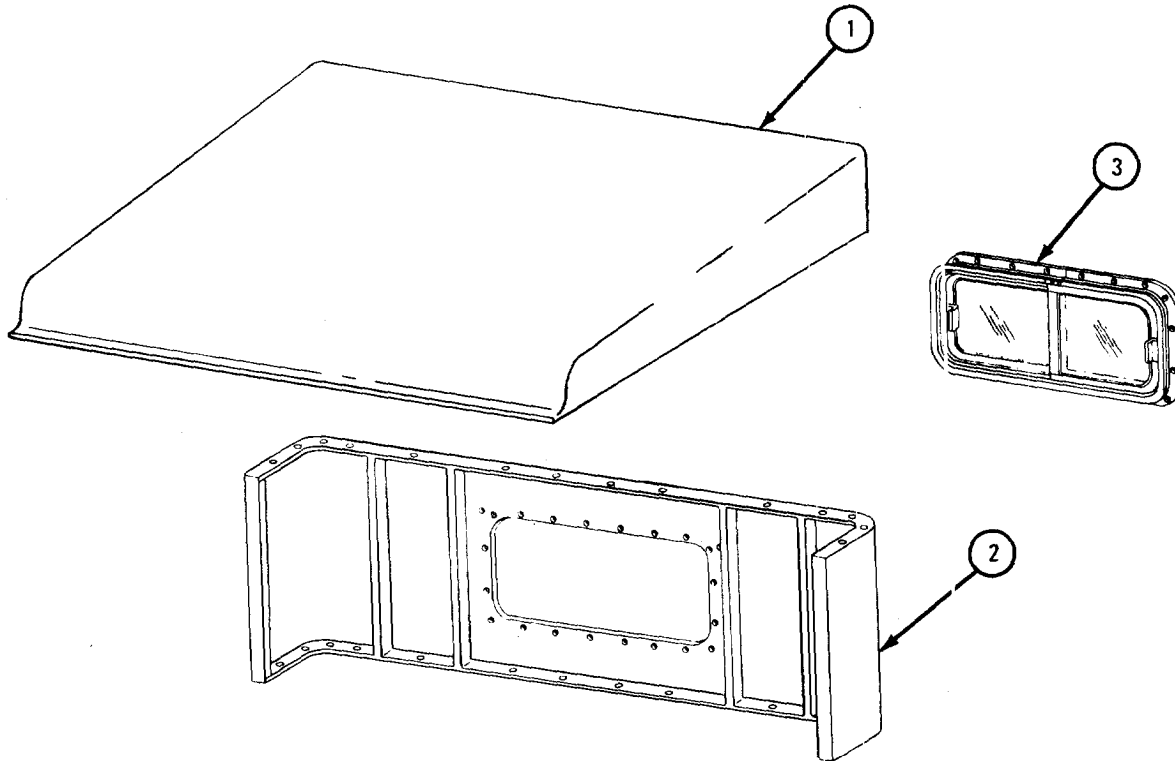

TA 102679

e. Assembly.

FRAME 1

Soldier A 1. Working outside back panel (1), put glass frame assembly (2) and frame cap (3) in place.

Soldier A 2. Aline screw holes and put in and hold 22 screws (4) .

Soldier B 3. Working inside back panel (1) , put on 22 washers (5) and 22 nuts (6).

GO TO FRAME 2

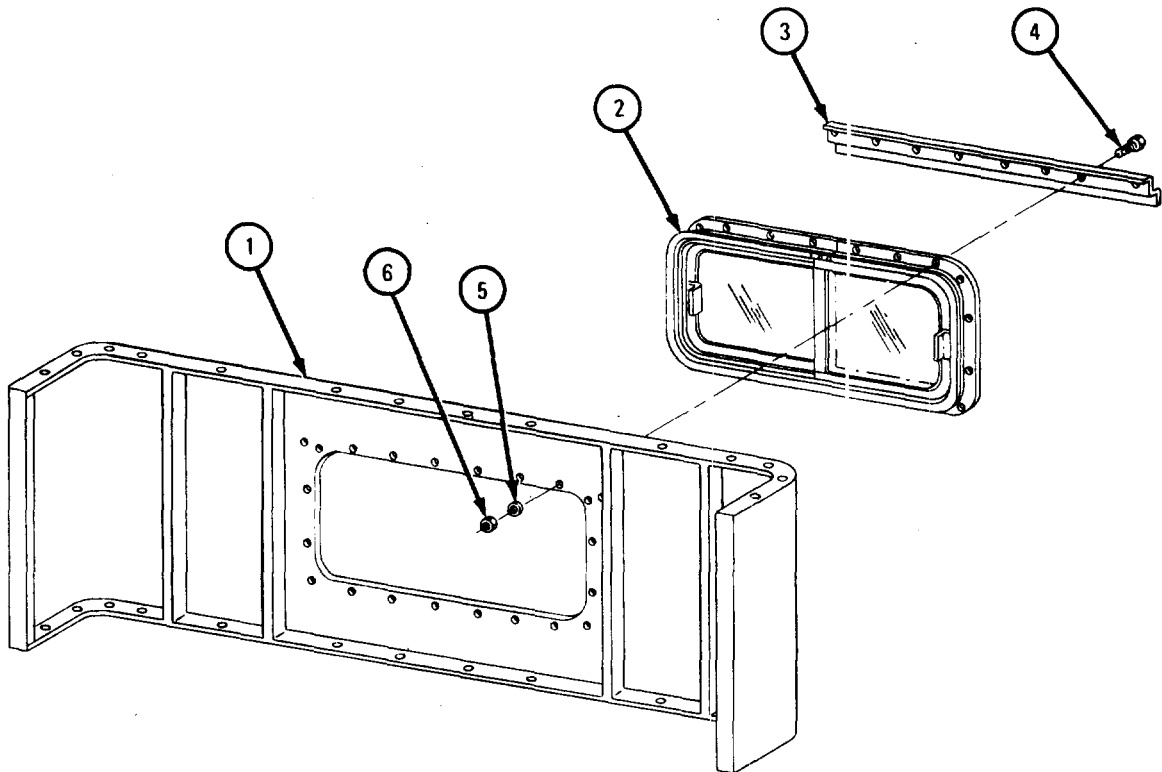

TA 102680

FRAME 2

1. Put adhesive on front roof panel seal (1).
2. Put front roof panel seal (1) in place and aline screw holes. Put in five screws (2) and nuts (3).

END OF TASK

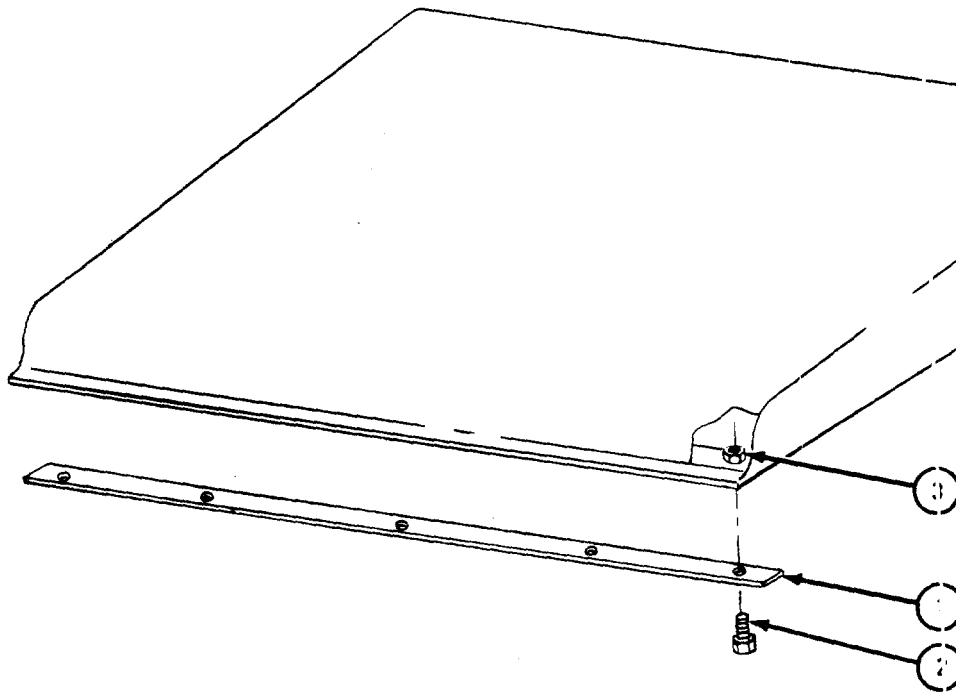

TA 103997

f. Replacement.

FRAME 1

1. Put adhesive on back panel seal (1). Place seal on cab (2) and align screw holes.

Soldiers A and B 2. Put back panel (3) in place on cab (2) and align screw holes.

Soldier A 3. Hold back panel (3) in place.

NOTE

Do not tighten capscrews until all capscrews are in place.

Soldier B 4. Put in 14 capscrews (4), 14 washers (5), and 14 nuts (6).

GO TO FRAME 2

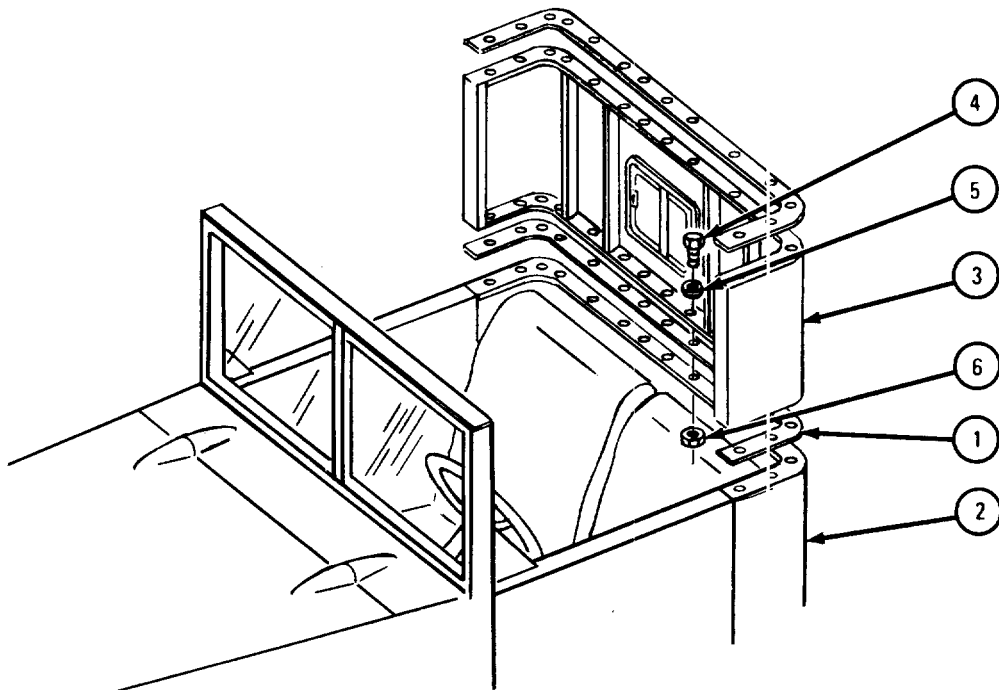

TA 102681

FRAME 2

1. Put in two capscrews (1) with two retainers (2).
2. Tighten all capscrews and nuts.
3. Glue rear roof panel seal (3) in place and aline screw holes.

GO TO FRAME 3

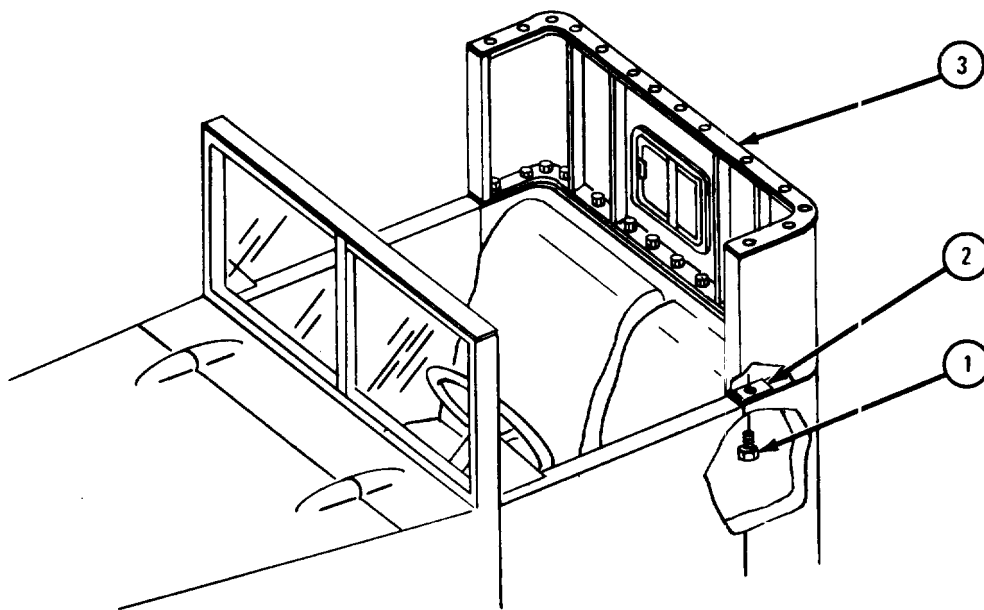

TA 104922

FRAME 3

Soldiers
A and B

1. Put roof panel (1) in place and align all screw holes.

NOTE

Do not tighten screws until all screws are in place.

2. Put in 14 capscrews (2), 28 washers (3), and 14 nuts (4).
3. Put in two capscrews (5), two clamps (6), and two nuts (7).
4. Put in two screws (8) and two washers (9), one on each side of roof panel (1). Tighten all screws.

END OF TASK

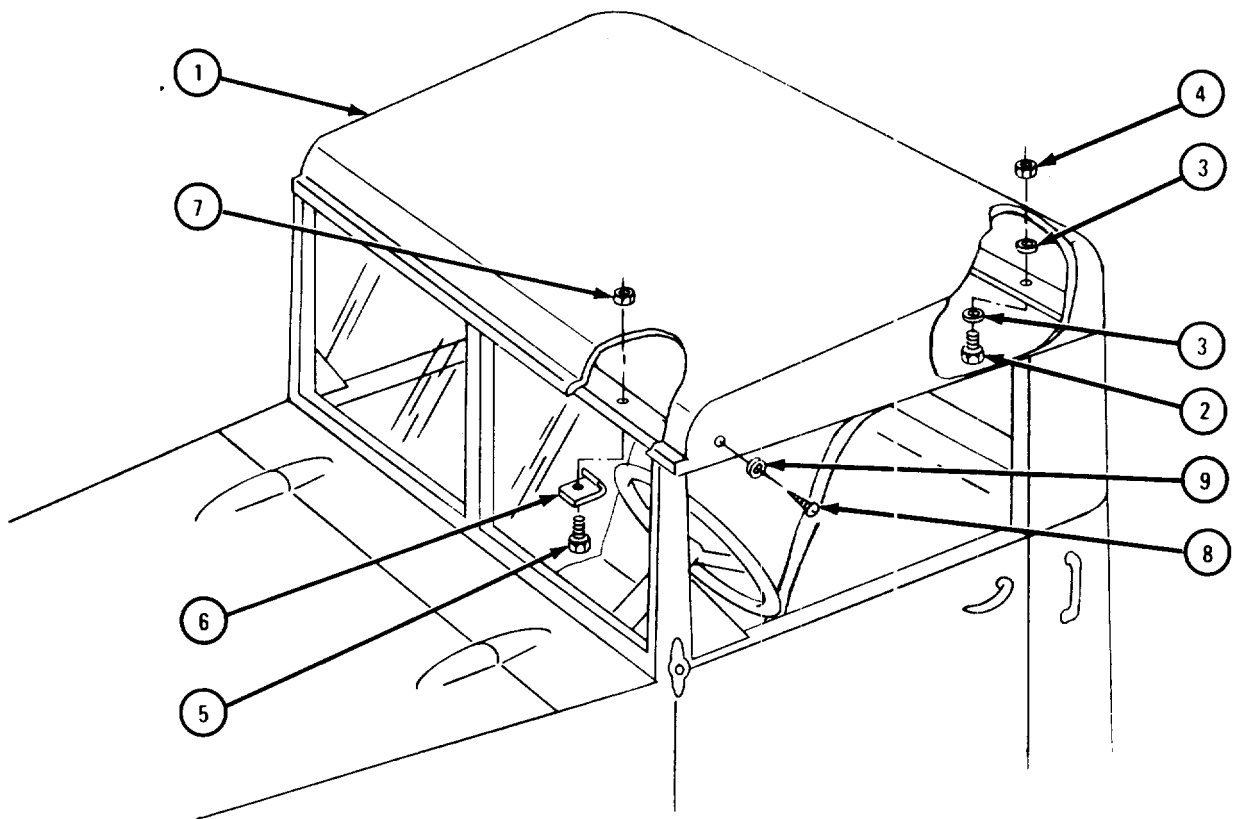

TA 102682

21-17. HEATER CONTROL BOX ASSEMBLY REMOVAL, REPAIR, REPLACEMENT,
AND TEST.

TOOLS: No special tools required

SUPPLIES : None

PERSONNEL: One

EQUIPMENT CONDITION: Truck parked, engine off, handbrake set.

a. Removal.

FRAME 1

1. Unplug electrical lead sockets (1) . Unscrew and unplug electrical connector (2).
2. Take out two screws (3).
3. Slide out control box panel (4).
4. Take out two capscrews with lockwashers (5) and two nuts and washers (6). Take out control box case assembly (7).

END OF TASK

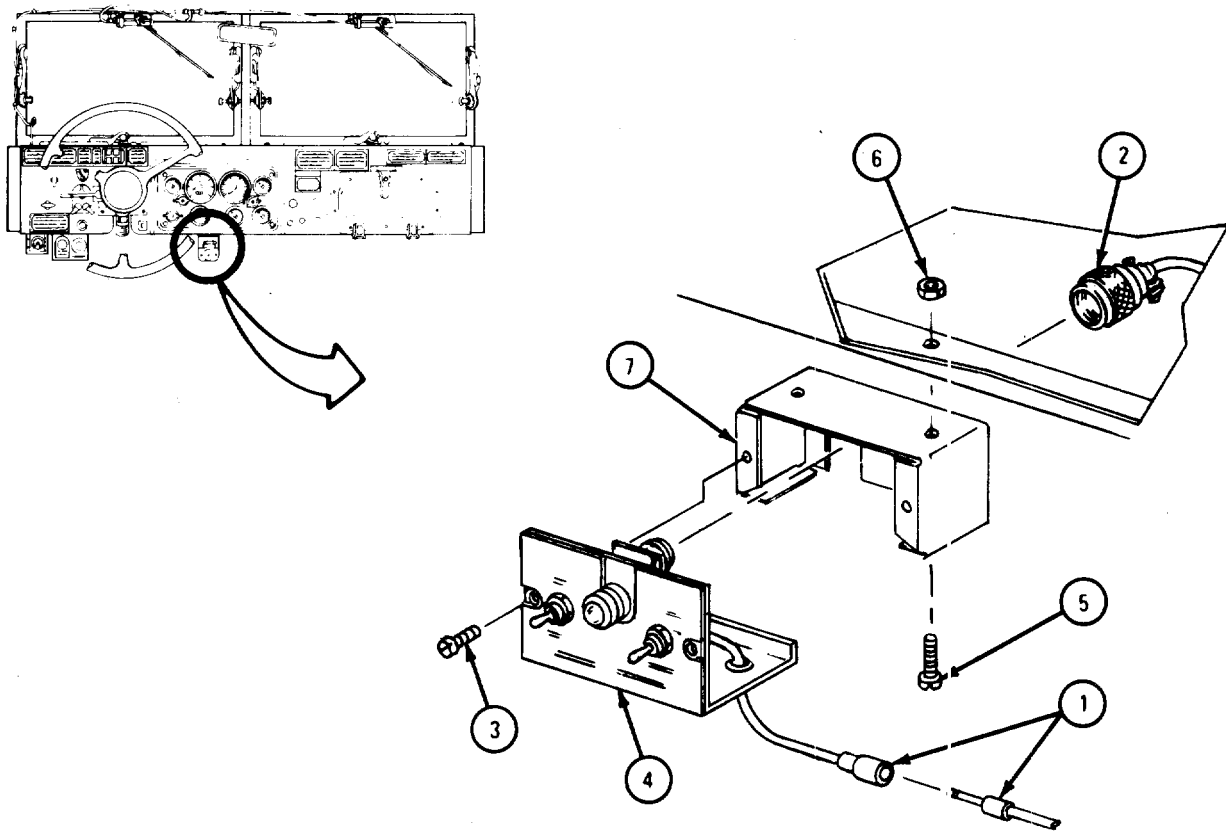

TA 118025

b. Disassembly.

NOTE

Tag all wires before taking them off so they will be put back in their right place.

FRAME 1

1. Take off two nuts (1) with washers (2).
2. Take out heater motor switch (3) and blower switch (4).
3. Take off six screws (5) from back of heater motor switch (3).
4. Take off connector jumper (6), connector (7), and six wires (8).
5. Take off two screws (9) from back of blower switch (4).
6. Take off two wires (10).

GO TO FRAME 2

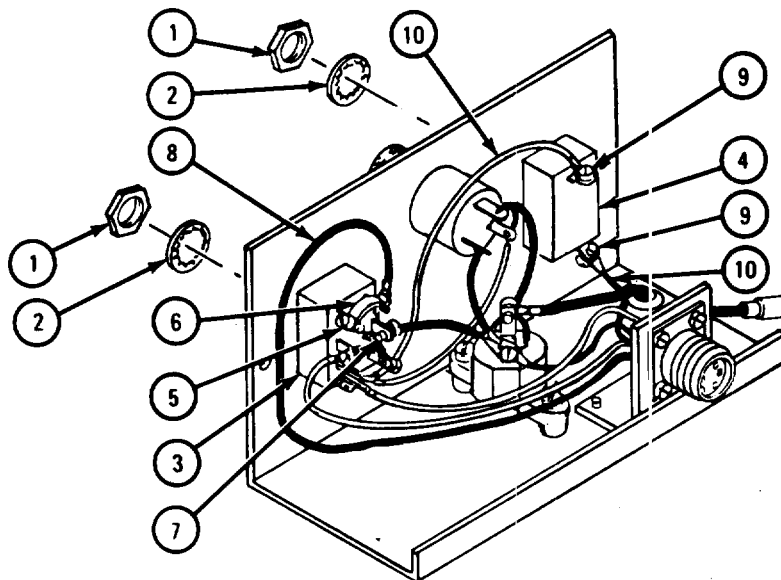

TA 105682

FRAME 2

1. Takeout two screws (1).
2. Take off wires (2 and 3) and push out grommet (4).
3. Take out two screws (5).
4. Take off electrical assembly (6) with angle bracket (7).
5. Unscrew four screws (8) and take electrical assembly (6) off angle bracket (7).

GO TO FRAME 3

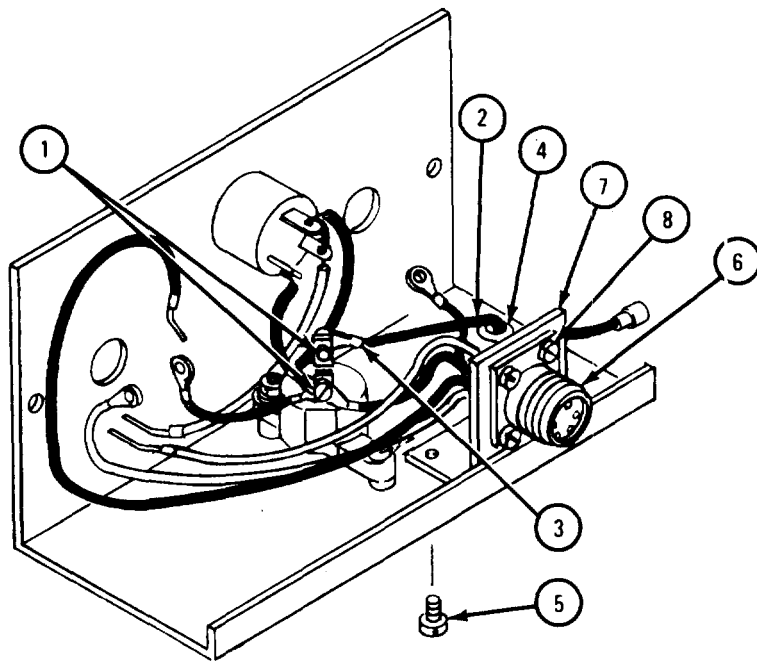

TA 103683

FRAME 3

1. Take off two screws (1) and two nuts (2).
2. Take off two spacers (3) and circuit breaker (4).
3. Unscrew and take off lens cap (5) and take out lamp (6).
4. Take off nut (7).
5. Take out indicator lamp assembly (8) and washer (9).
6. Take off data plate (10).

END OF TASK

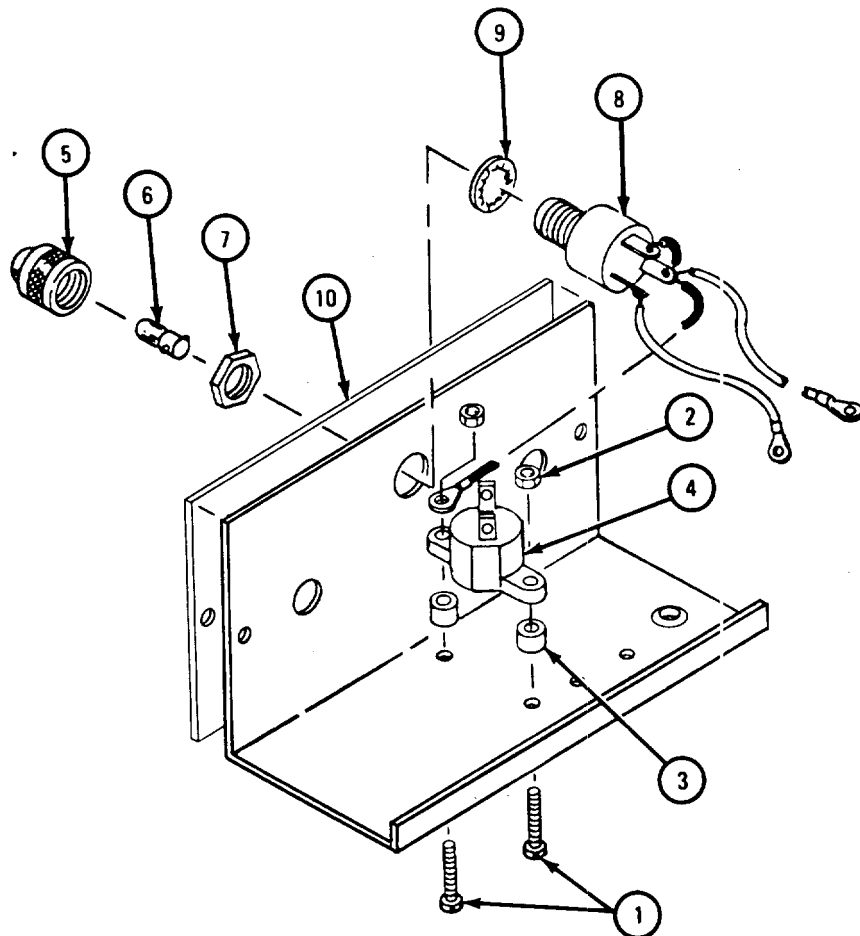

TA 105684

c. Inspection and Repair.

- (1) Check that all threaded parts have no stripped or damaged threads.
- (2) Check that all wires have no cracked, burned or worn insulation.
- (3) Check that switches have no damaged, burned or cracked terminals.
- (4) Check that lamp is not burned out.
- (5) Replace any damaged parts with new parts.

d. Assembly.

FRAME 1

1. Put indicator lamp assembly (1) with washer (2) into hole in center of control box panel (3).
2. Put data plate (4) in place.
3. Put on nut (5).
4. Put in lamp (6) and put on lens cap (7).

GO TO FRAME 2

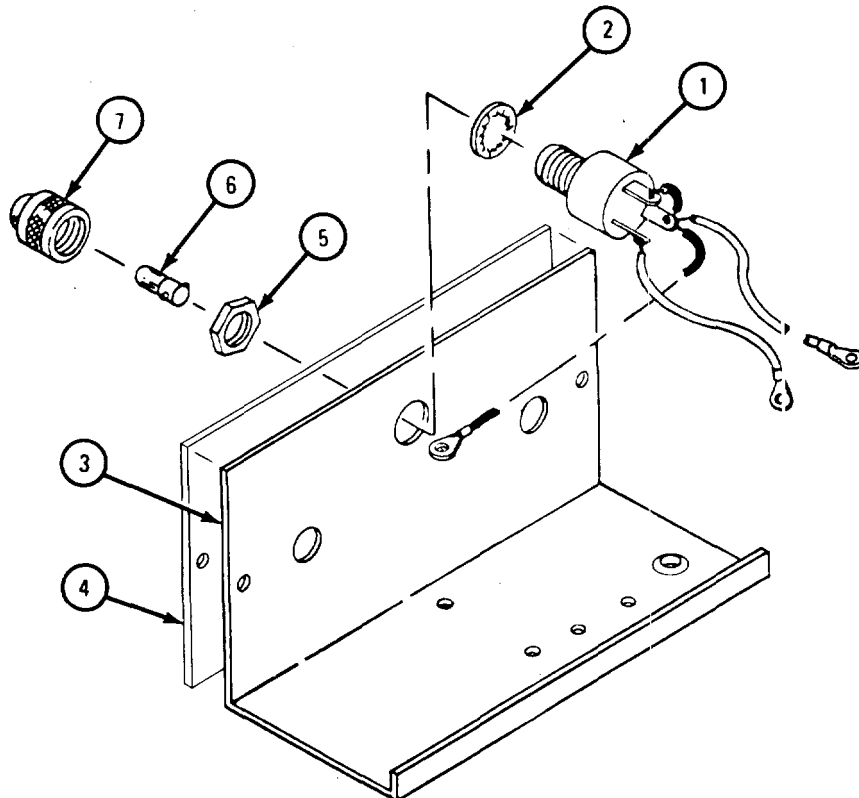

TA 105686

FRAME 2

1. Line up holes in circuit breaker (1), two spacers (2) and lug (3) with holes in control box panel (4).
2. Put in two screws (5) and two nuts (6).

GO TO FRAME 3

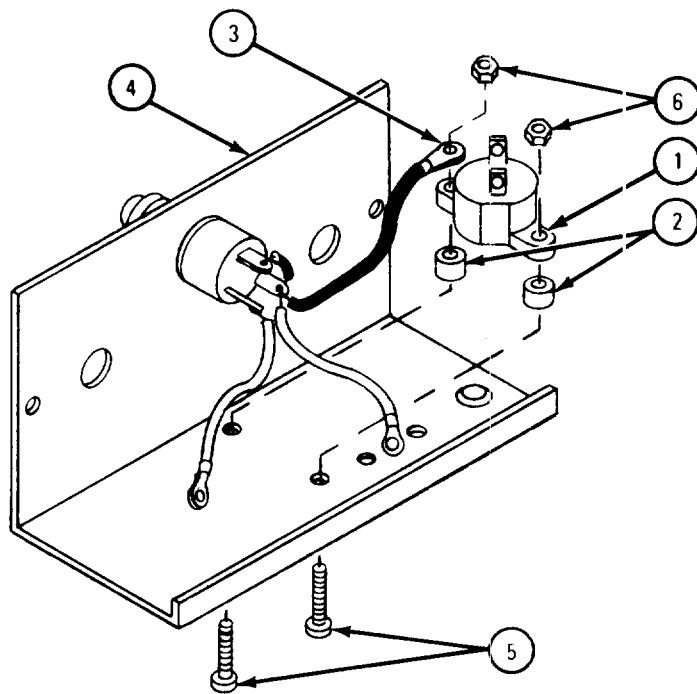

TA 105697

FRAME 3

1. Put electrical assembly (1) into angle bracket (2) and line up holes.
 2. Put in four screws (3).
 3. Put angle bracket (2) in place as shown, and line up holes.
 4. Put in two screws (4).
 5. Put grommet (5) in hole as shown and put wire (6) through grommet.
 6. Put in screw (7) with lug (8).
 7. Put in screw (9) with three wires (10) as tagged. Take off tags,
- GO TO FRAME 4

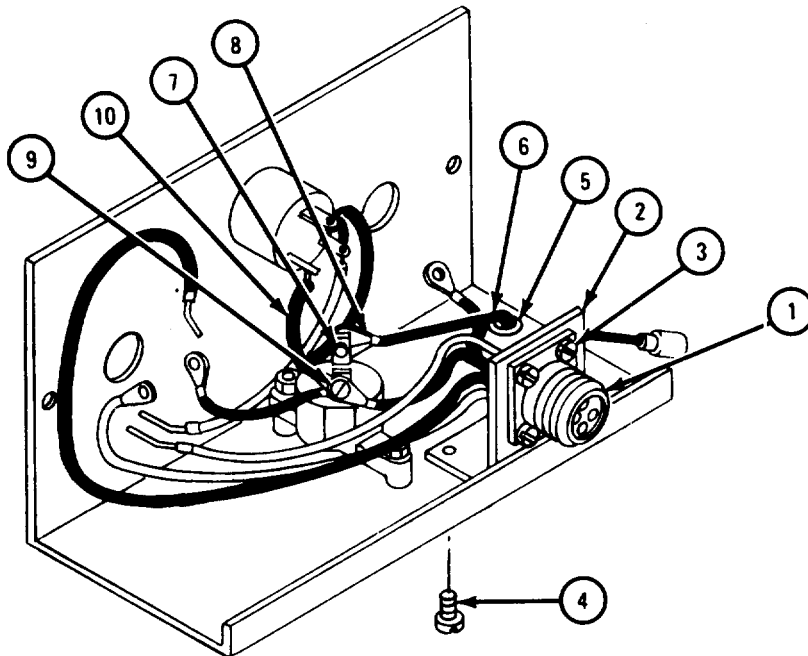

TA 105687

FRAME 4

1. Put in two screws (1) with two wires (2) as tagged.
2. Put connector jumper (3) and connector (4) on back of heater motor switch (5) as shown.
3. Put in six screws (6) with six wires as tagged.
4. Put blower switch (7) through hole in control box panel (8) marked HI-LOW.
5. Put heater motor switch (5) through hole in control box panel (8) marked RUN-OFF-START .
6. Put on two nuts (9) with washers (10).
7. Take off tags.

END OF TASK

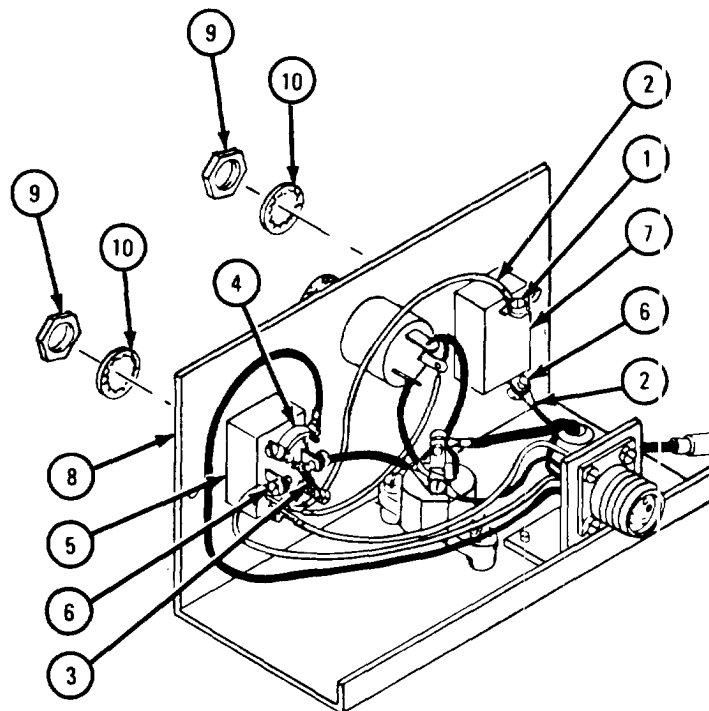

TA 105688

e. Replacement.

FRAME 1

1. Aline screw holes in control box assembly (1) with screw holes in instrument panel (2).
2. Put in two capscrews and lockwashers (3) and two nuts and washers (4).
3. Slide in control box panel (5). Put in two screws (6).
4. Plug in electrical lead sockets (7).
5. Aline pins on electrical plug (8) and plug it into socket (9) on back of control box assembly (1). Put in nut (9).

END OF TASK

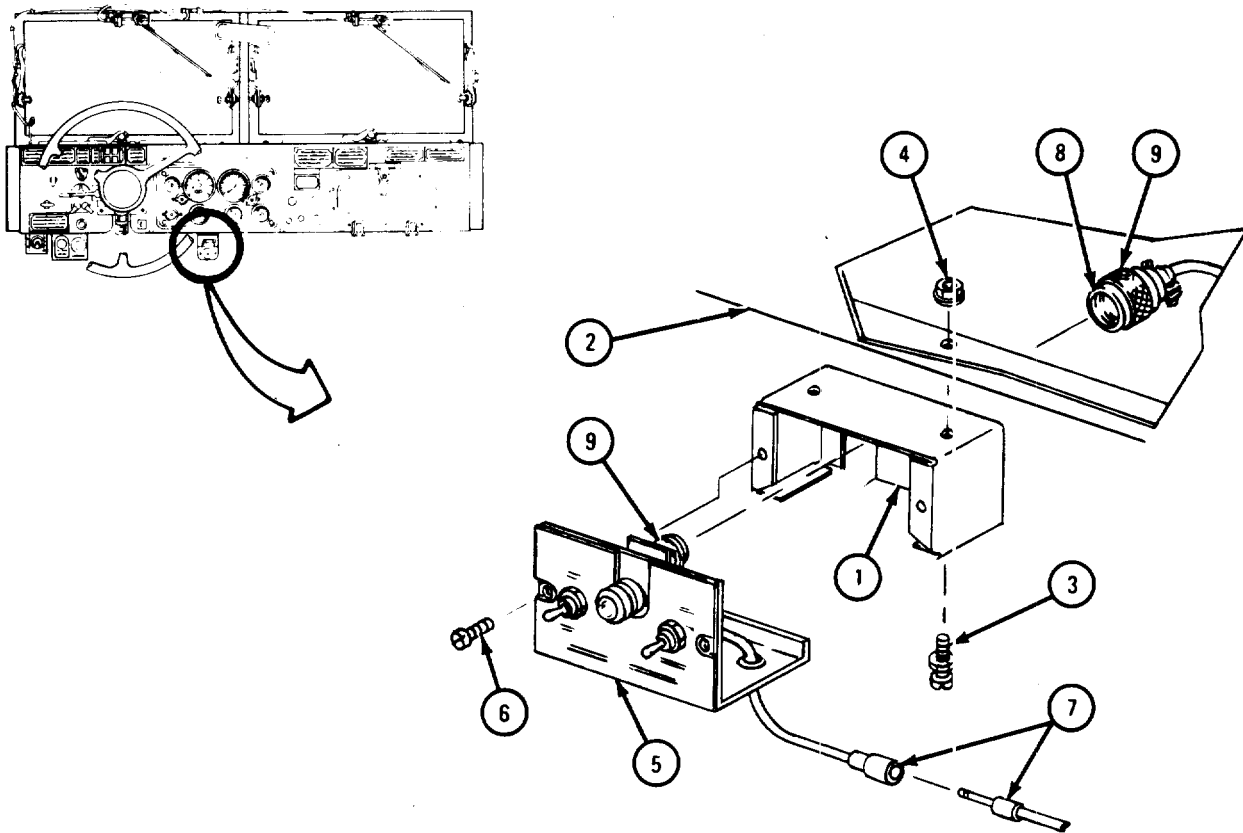

TA 118026

f. Functional Test.

FRAME 1

1. Make sure emergency switch (1) is in ON position.
2. Pull AIR control knob (2) all the way out.
3. Set heater motor switch (3) to START position,. Hold switch in this position for at least 10 seconds or until indicator lamp (4) lights.
4. Set heater motor switch (3) to RUN position.

NOTE

If heater motor switch (3) is moved to RUN position before indicator lamp (4) lights, heater will not work.

5. Set blower switch (5) to LO position, then set switch to HI position.
6. A change in blower speed should be noted. Air coming from heater should be very warm.
7. Set heater motor switch (3) to OFF position.
8. Push in AIR control knob (2).

END OF TASK

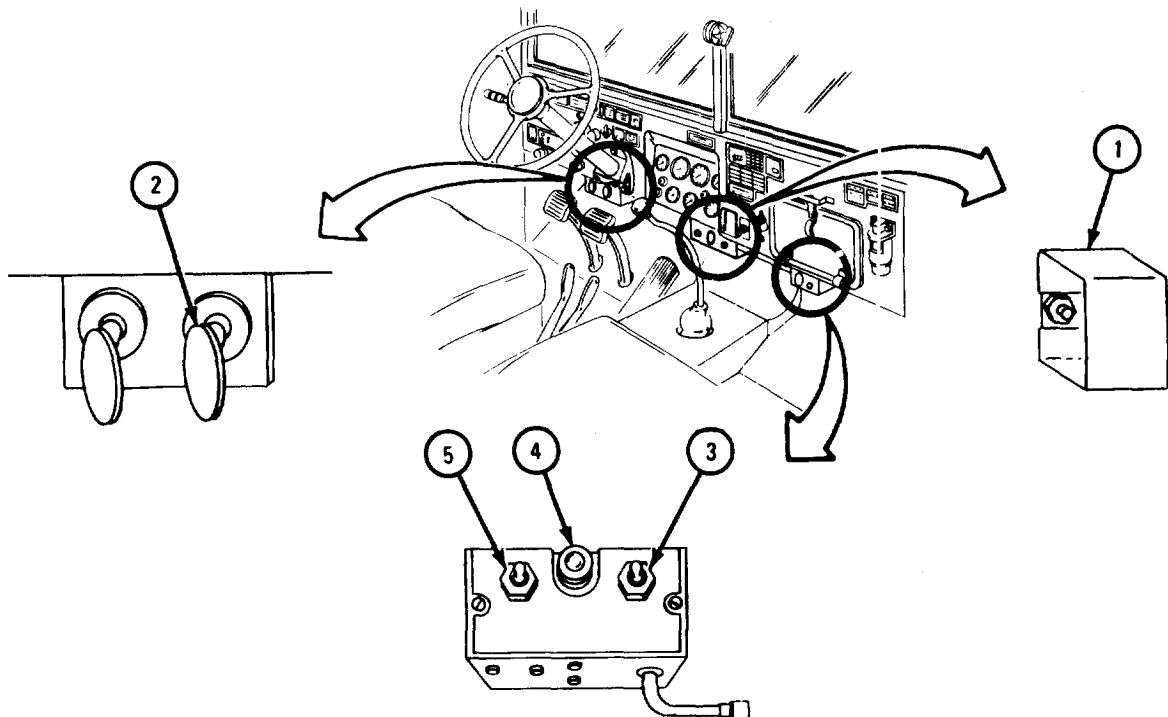

TA 105689

21-18. SLAVE RECEPTACLE KIT INSTALLATION. Install kit using instructions that come with kit.

Section III. DEEP WATER FORDING KIT

21-19. DEEP WATER FORDING KIT INSTALLATION. Install deep water fording kit using instructions that come with the kit.

21-20. DEEP WATER FORDING KIT OPERATING TESTS .

TOOLS : No special tools required

SUPPLIES : Soapy water

PERSONNEL : Two

EQUIPMENT CONDITION : Truck parked, handbrake set, transmission in neutral position, fording control handle pulled out, engine off.

a. Preliminary Procedure. Open hood. Refer to Engine Equipment Items Maintenance, TM 9-2320-209-10.

b. Intake Operating Test.

WARNING

If engine is running indoors, make sure that truck is in a well-ventilated area and exhaust fumes are vented directly outdoors. Breathing in of fumes will cause injury to personnel.

FRAME 1

1. Take out flywheel housing drain plug (1) and put it into drain port hole (2).
 2. Start engine. Refer to General Operating Procedures, TM 9-2320-209-10.
- GO TO FRAME 2

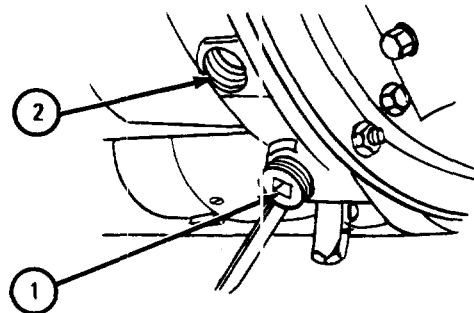
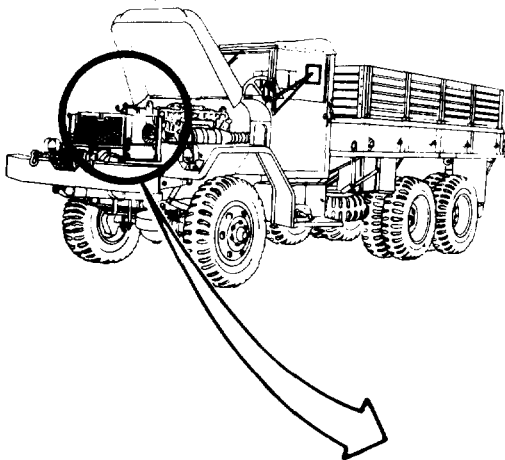

TA 103281

FRAME 2

1. Take off intake extension cap (1) and cover the opening of the intake extension tube (2) .
2. Uncover extension tube before engine stalls.

IF ENGINE DOES NOT BEGIN TO STALL, GO TO FRAME 3.
IF ENGINE BEGINS TO STALL, END OF TASK

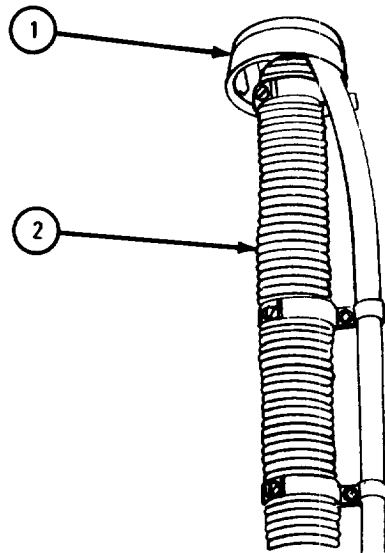

TA 103282

FRAME 3

1. Check that intake extension tube clamp (1) is not loose. If clamp is loose, tighten clamp screw (2).
2. Check that air cleaner-to-air compressor hose clamps (3 and 4) are not loose. If clamps are loose, tighten clamp screw (2). If more repair is needed, refer to para 21-21.

END OF TASK

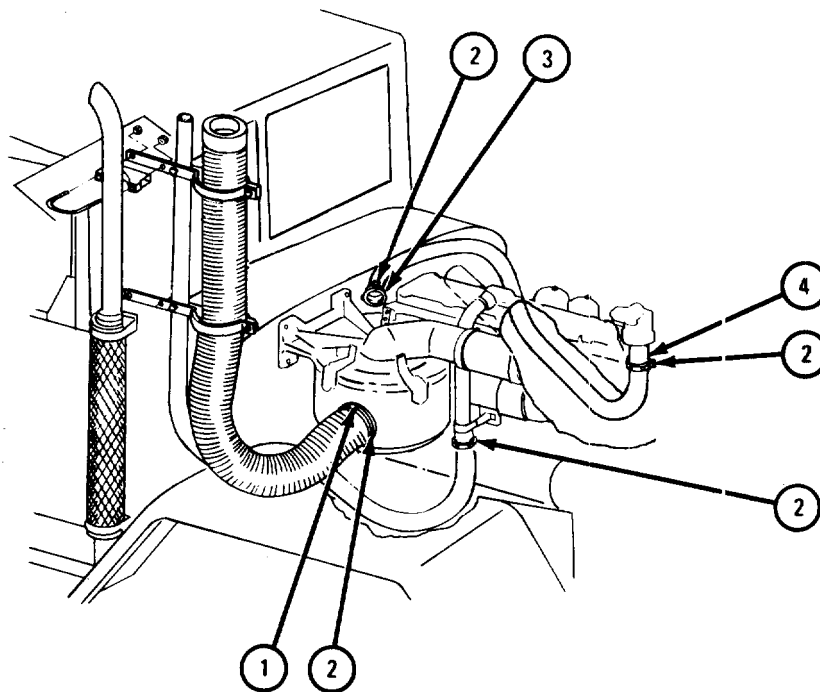

TA 103283

c. Vent Operating Test.

FRAME 1

Soldier A 1. Cover opening in tube (1).

Soldier B 2. Using soapy water, check that there are no pressure leaks around connection (2). If bubbles appear, tighten clamp screw (3). If more repair is needed, refer to para 21-21.

END OF TASK

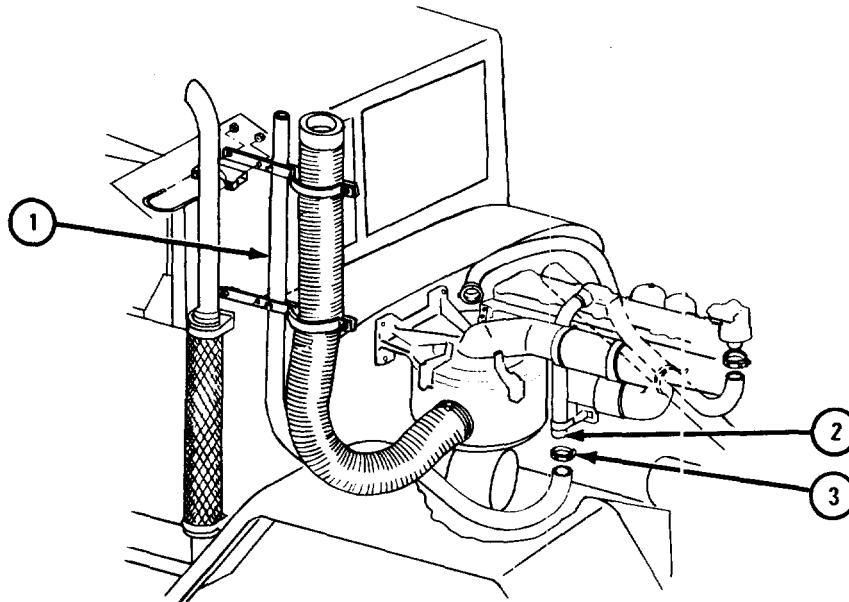

TA 103284

d. Exhaust Operating Test.

FRAME 1

1. Hold upper exhaust extension weathercap (1) closed.
 2. Release weathercap before engine stalls.
- IF ENGINE DOES NOT BEGIN TO STALL, GO TO FRAME 2.
IF ENGINE BEGINS TO STALL, END OF TASK

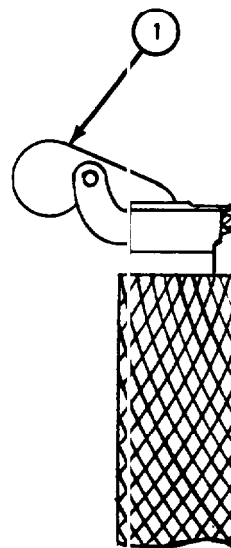
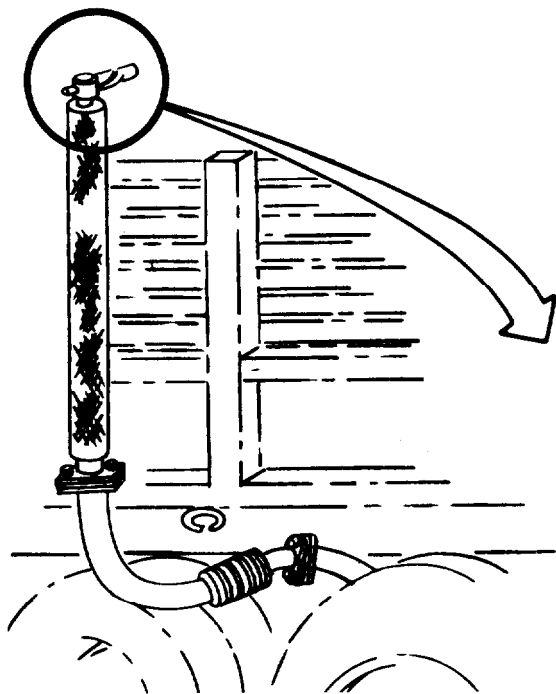

TA 103285

FRAME 2

1. Check that five screws (1) are not loose. If screws are loose, tighten them. If more repair is needed, refer to para 21-21.

GO TO FRAME 3

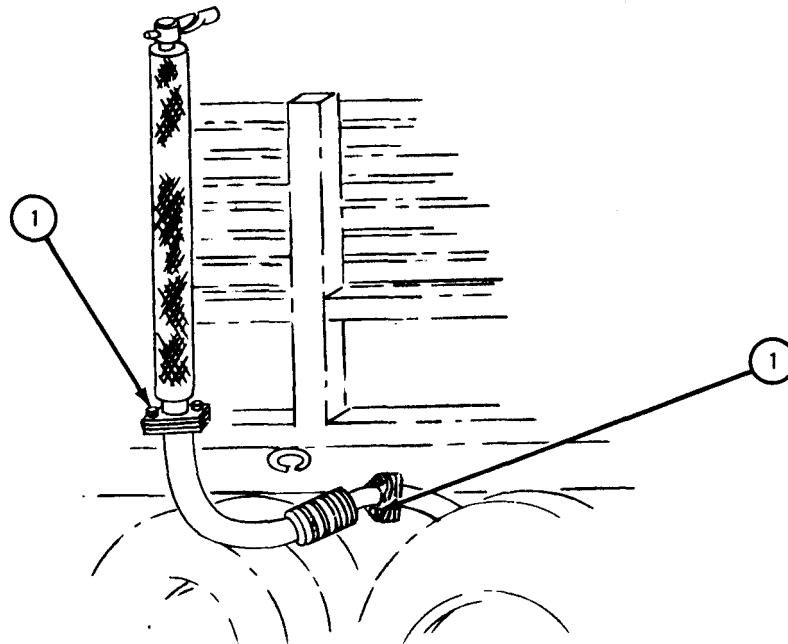

TA 103286

FRAME 3

1. Test air pressurizing system with air system leak test. Refer to TM 9-2320-209-20.
2. Turn off engine. Refer to General Operating Procedures, TM 9-2320-209-10.
3. Take out flywheel housing drain plug (1) and put it into storage boss hole (2).

NOTE

Follow-on Maintenance Action Required:

Close hood. Refer to Engine Equipment General Maintenance, TM 9-2320-209-10.

END OF TASK

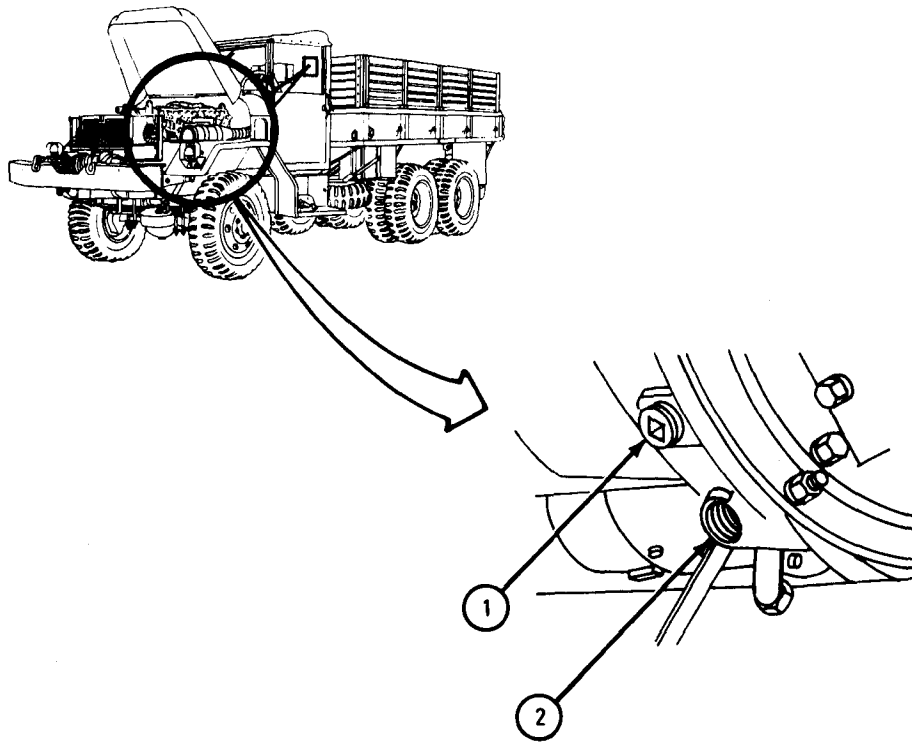

TA 103287

21-21. DEEP WATER FORDING KIT REMOVAL, REPAIR, AND REPLACEMENT.

TOOLS: No special tools required

SUPPLIES: Cotter pin
Tie down strap (2)
Exhaust extension gasket (2)
Lubricating oil, ICE, OE/HDO 30, MIL-L-2104
Clean rags
Solvent, dry cleaning, type II (SD-2), Fed. Spec P-D-680

PERSONNEL: Two

EQUIPMENT CONDITION: Truck parked, engine off, handbrake set.

a. Preliminary Procedures.

- (1) Open hood and left side panel. Refer to TM 9-2320-209-10.
- (2) Remove control valve. Refer to TM 9-2320-209-20.
- (3) Remove transmission breather. Refer to TM 9-2320-209-20.

b. Removal.

FRAME 1

1. Unscrew four connecting nuts (1) and take out tube (2).
2. Cut strap (3) and takeout hose (4).
3. Take off elbow (5).
4. Take off two nuts (6).
5. Take out two screws (7) and angle bracket (8).
6. Do steps 4 and 5 again for shutoff control (9).

GO TO FRAME 2

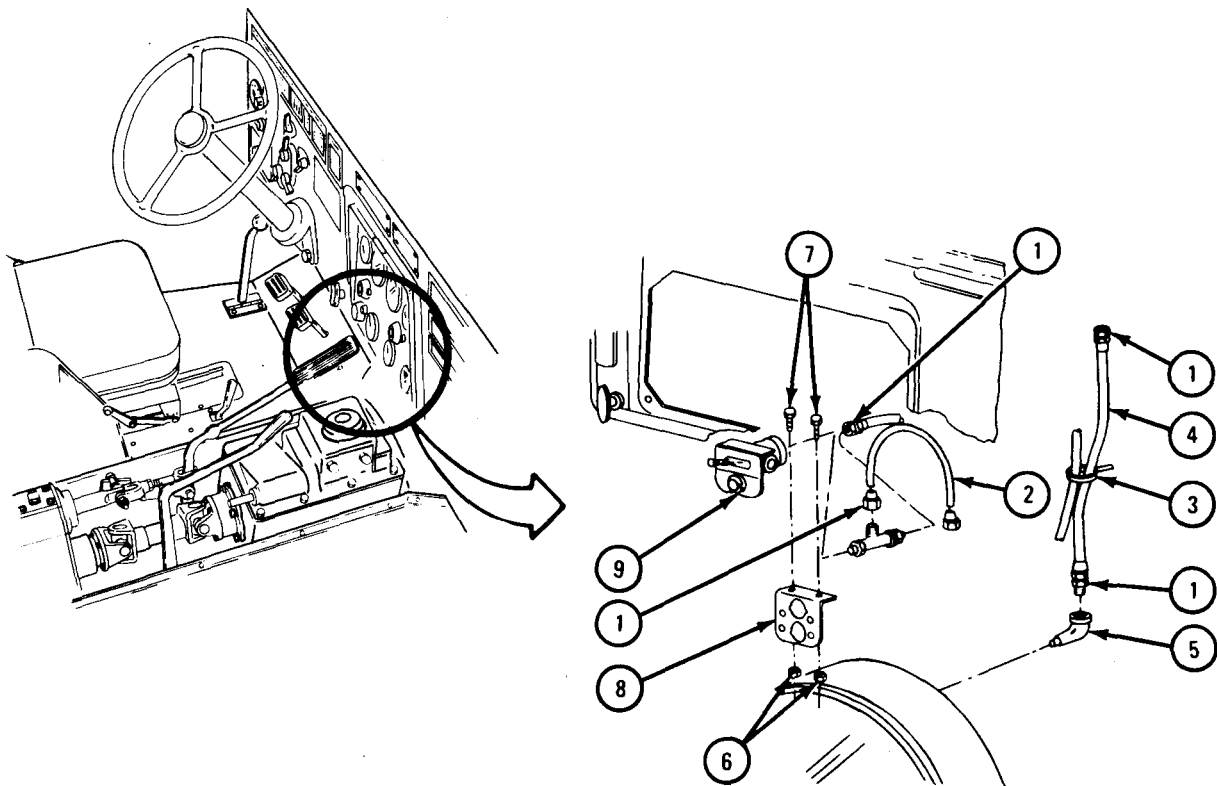

TA 103288

FRAME 2

Soldier A 1. Working under instrument panel, take off tube (1).

Soldier B 2. Working underwood, takeoff elbow (2), nipple (3), nut (4), and washer (5).

Soldier A 3. Takeout valve assembly (6) and washer (7).

IF WORKING ON TRUCKS M35A1 OR M35A2, GO TO FRAME 3.

IF WORKING ON ALL OTHER TRUCKS, GO TO FRAME 10

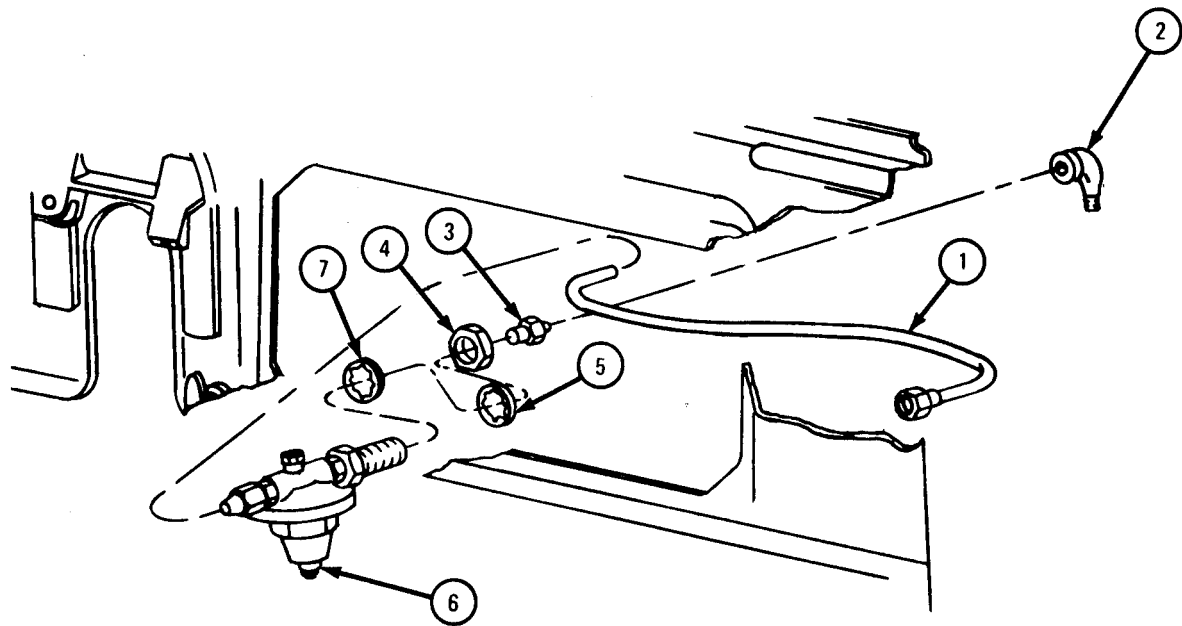

TA 103289

FRAME 3

1. Loosen clamp screw (1) and take out air tube (2).
 2. Turn two side panel latches (3) to the up position and lower right side panel (4).
- GO TO FRAME 4

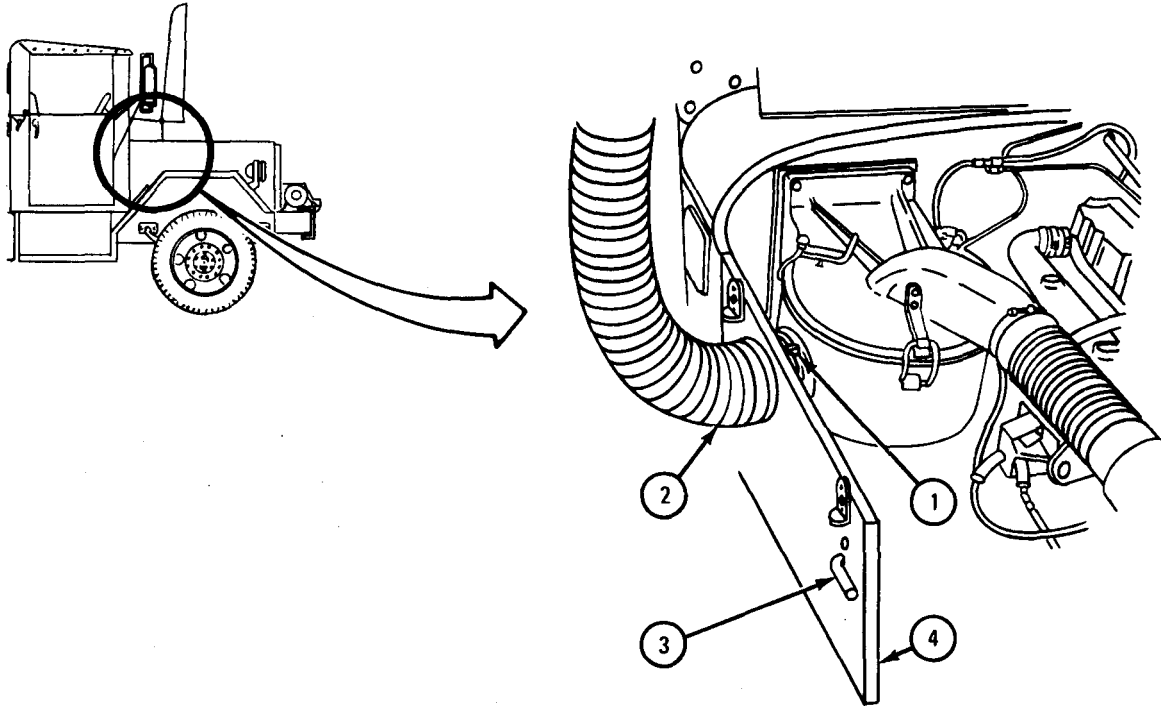

TA 103290

FRAME 4

1. Take off cap (1).
2. Loosen three clamp screws (2).
3. Cut strap (3) and takeout hose (4) and two clamps (5).
4. Take off two nuts (6) and washers (7).
5. Take off hose (8) with clamp (9) and two clamps (10).

GO TO FRAME 5

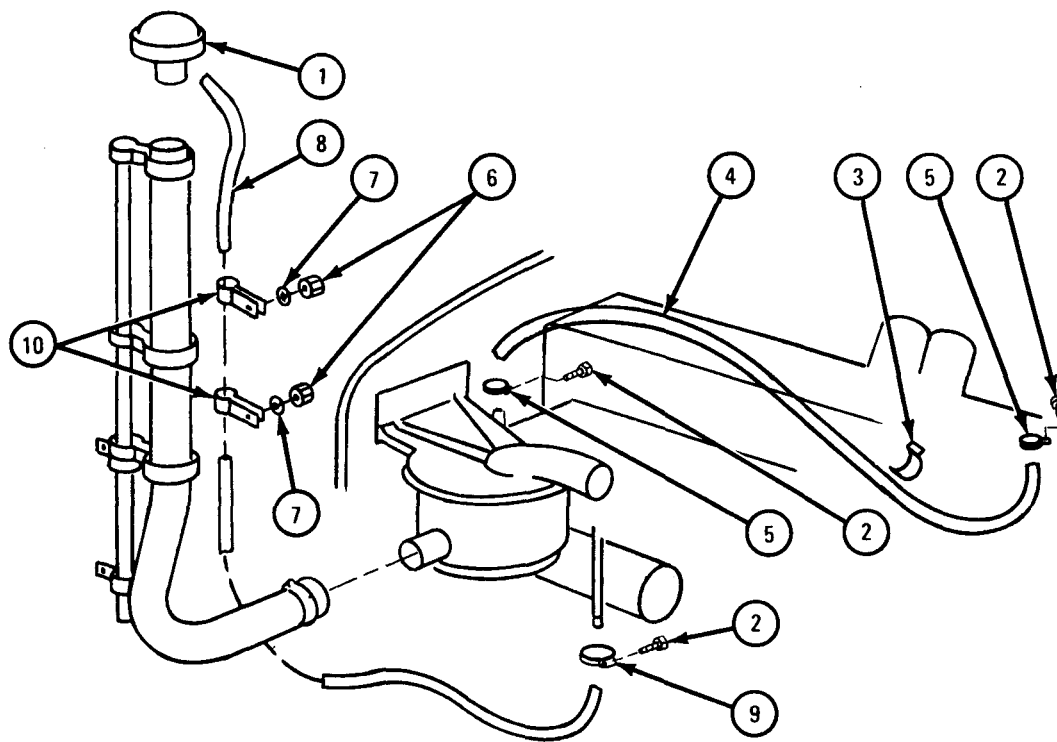

TA 103291

FRAME 5

1. Take off three nuts (1) and washers (2).
2. Take out three screws (3).
3. Take off tube (4) and three clamps (5).
4. Take out and throw away cotter pin (6).
5. Take out two screws (7) and take off rod (8).

GO TO FRAME 6

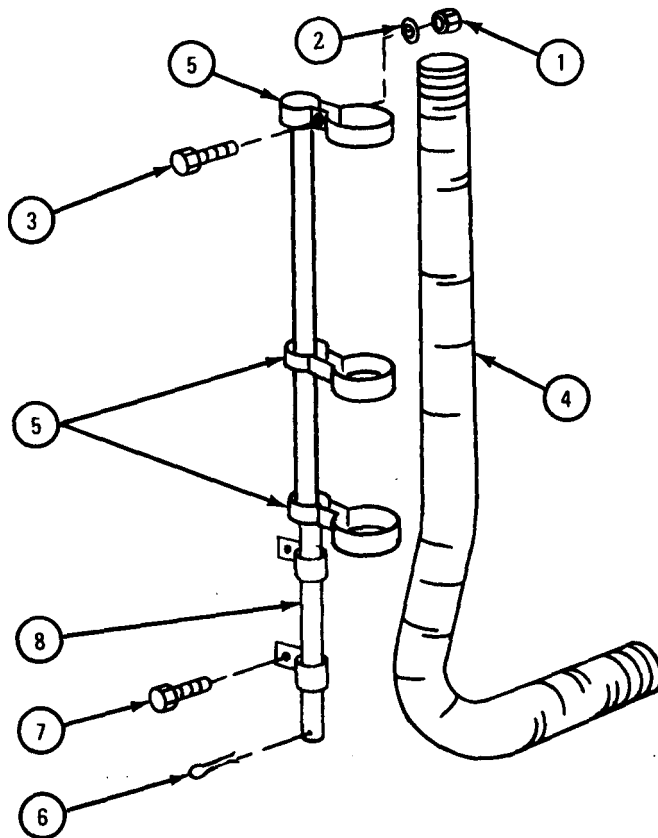

TA 103292

FRAME 6

1. Takeoff three nuts (1) and take out screws (2).
 2. Take off nut (3), washer (4), and take out screw (5).
 3. Take off upper exhaust extension (6) and gasket (7). Throw away gasket.
- GO TO FRAME 7

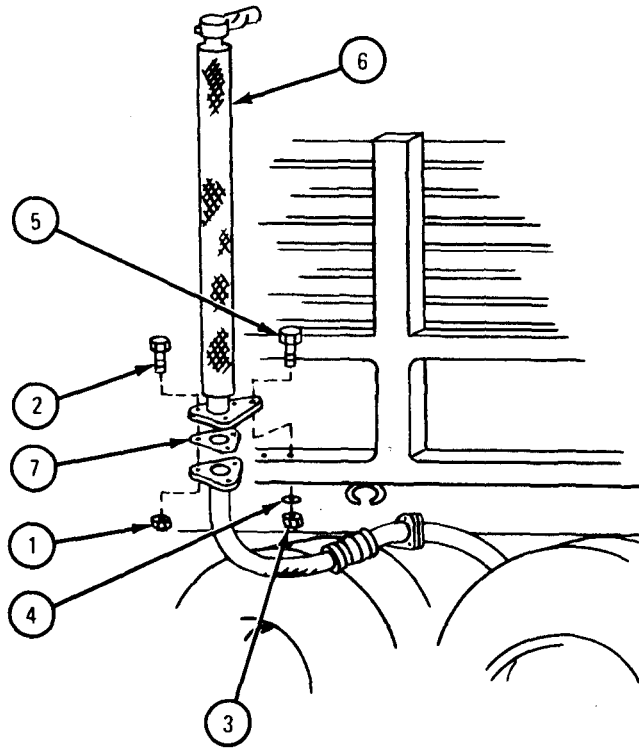

TA 103293

FRAME 7

1. Take off three nuts (1).
2. Take out three screws (2).
3. Take off lower exhaust extension (3) and gasket (4). Throw away gasket.

GO TO FRAME 8

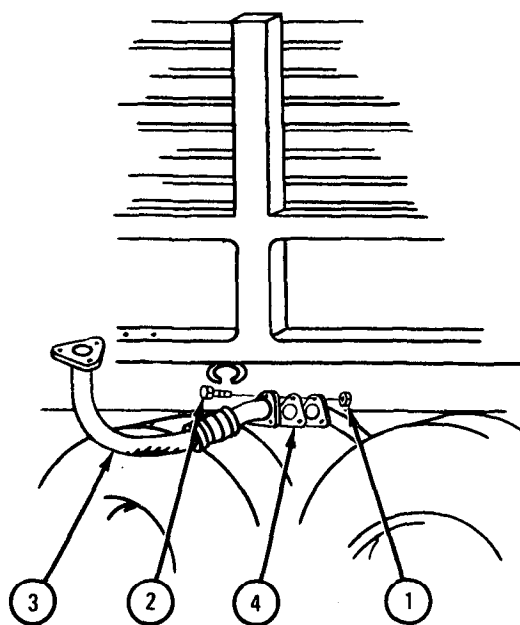

TA 103294

FRAME 8

1. Unscrew two coupling nuts (1).
2. Take off elbow pipe (2).
3. Unscrew two coupling nuts (3) and takeoff tube (4).
4. Take off two elbows (5).
5. Take out screw (6).
6. Unscrew coupling nut (7) and take out line (8).

GO TO FRAME 9

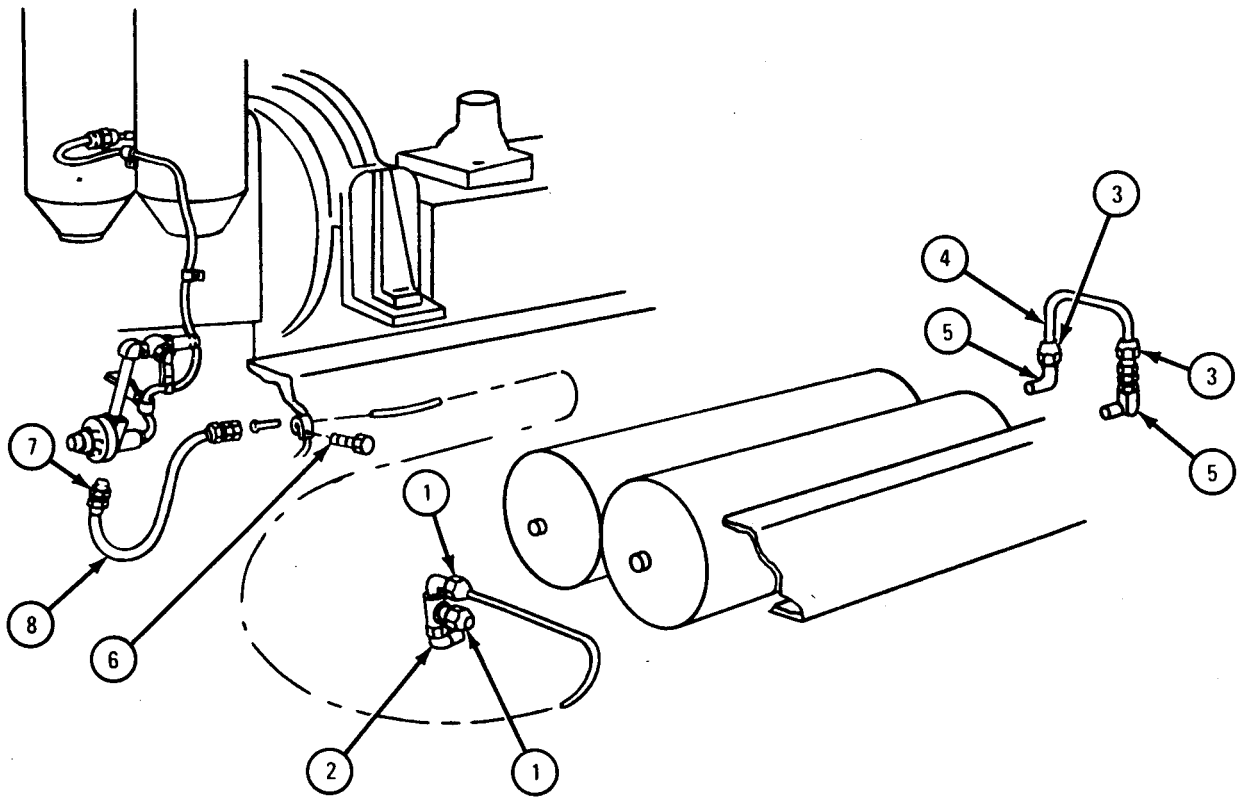

TA 103295

FRAME 9

1. Take cable (1) out of control switch (2).
2. Take off nut (3) and lockwasher (4).
3. Take off rubber grommet (5) and control switch (2).
4. Take screw (6) out of three clips (7).
5. Takeout cable (1) and three clips (7).
6. Take out pipe nipple (8) and valve (9).

END OF TASK

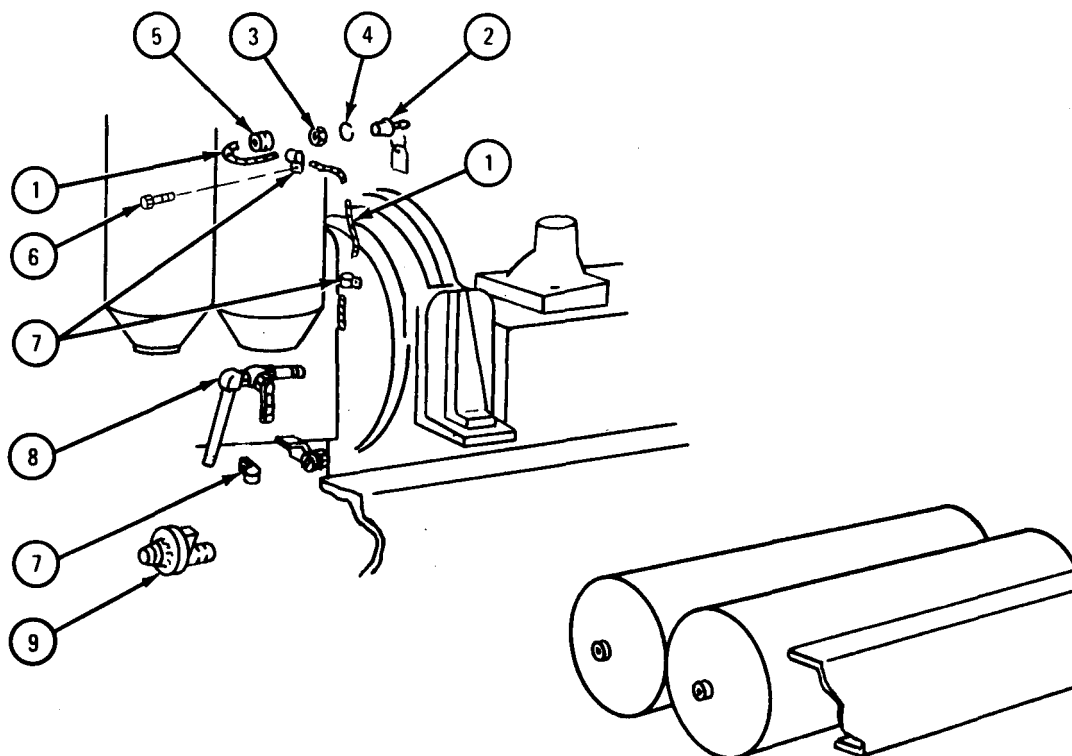

TA 103296

FRAME 10

1. Loosen clamp screw (1) and take out air tube (2).
2. Turn two side panel latches (3) to the up position and lower right side panel (4).

GO TO FRAME 11

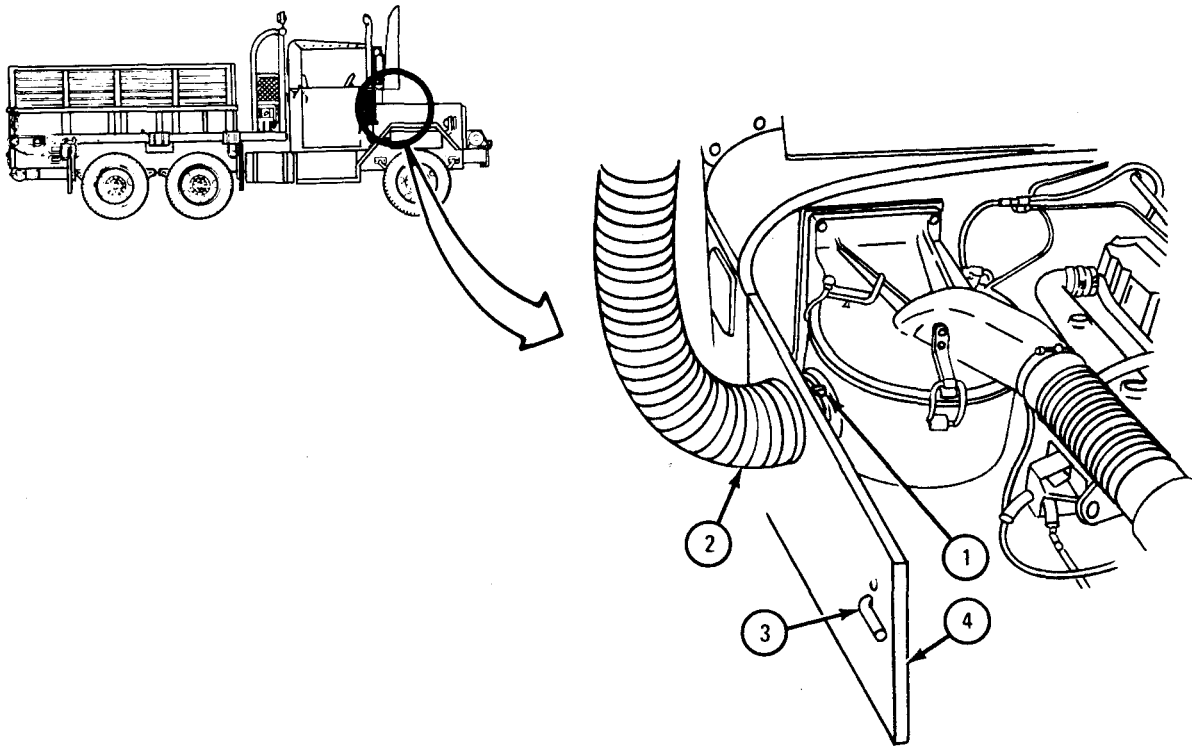

TA 103297

1. Take off cap (1).
2. Loosen three clamp screws (2).
3. Cut strap (3) and take out hose (4) and two clamps (5).
4. Take off four nuts (6).

GO TO FRAME 12

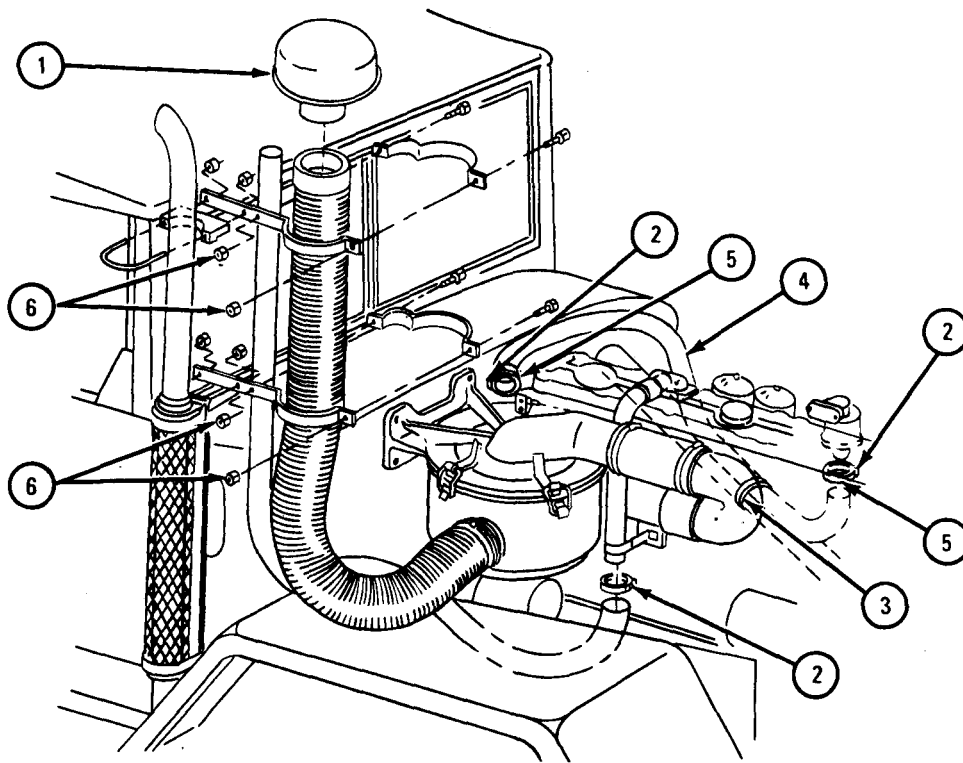

TA 103298

FRAME 12

1. Take out four screws (1).
2. Take off both halves of two clamps (2).
3. Take off hoses (3 and 4).
4. Take off four nuts (5).
5. Take off two other halves of two clamps (2).
6. Take off clamp (6).

END OF TASK

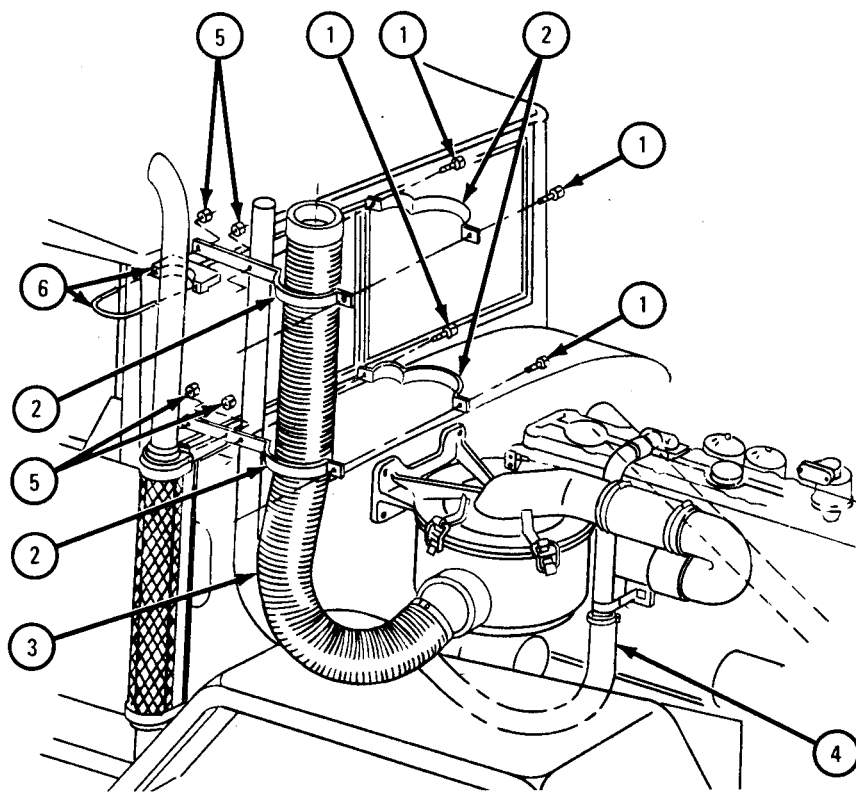

TA 103299

c. Cleaning. There are no special cleaning procedures needed. Refer to cleaning procedures given in Part 1, para 1-3.

d. Inspection and Repair.

FRAME 1

1. Check that two tubes (1) are not bent, cracked or have any holes. If tubes are damaged, get new ones.
2. Check that hose (2) is not cracked or has any holes. If hose is damaged, get a new one.
3. Check that valve assembly (3) and shutoff (4) work properly and are not damaged. If parts are damaged, get new ones.
4. Check that all threaded parts are not stripped or crossthreaded. If parts are damaged, get new ones.

IF WORKING ON TRUCKS M35A1 OR M35A2, GO TO FRAME 2.

IF WORKING ON OTHER TRUCKS, GO TO FRAME 5

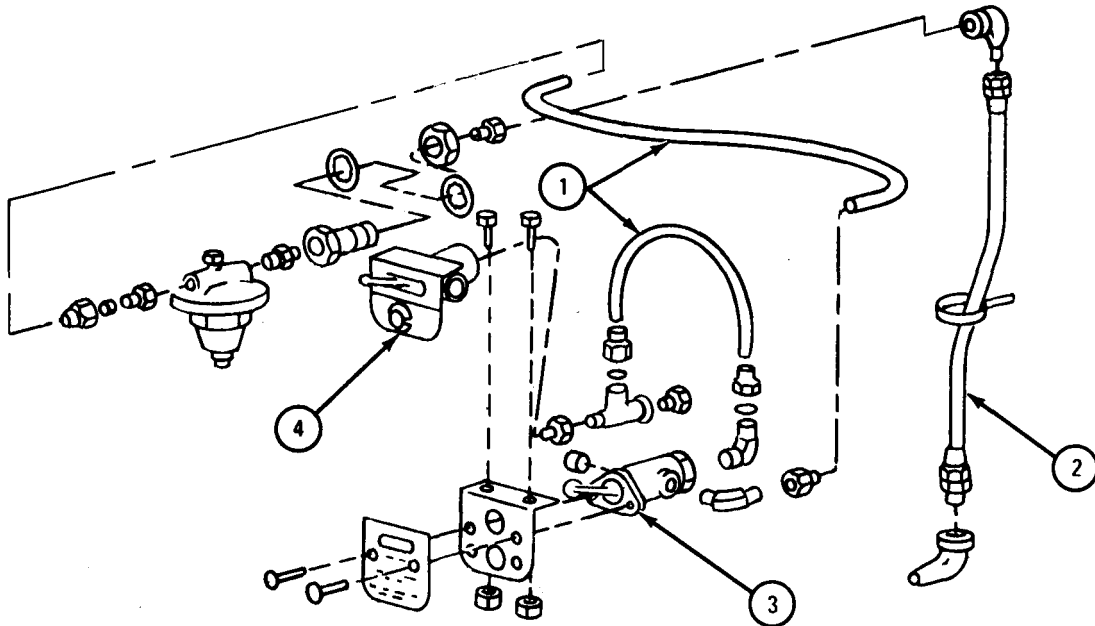

NOTE: CHECK ONLY THOSE PARTS WHICH ARE CALLED OUT IN THIS FRAME. PARTS WITHOUT CALLOUTS ARE SHOWN ONLY FOR REFERENCE PURPOSES OR ARE CHECKED IN ANOTHER FRAME.

TA 103300

FRAME 2

1. Check that two tubes (1) are not bent, cracked or have any holes. If tubes are damaged, get new ones.
2. Check that hose (2) is not cracked or has any holes. If hose is damaged, get a new one.
3. Check that valves (3 and 4) are not binding or worn. If valves are damaged, get new ones.
4. Check that cable (5) is not frayed, worn or kinked. If cable is damaged, get a new one.
5. Check that switch (6) works properly and is not damaged. If switch is damaged, get a new one.
6. Check that all threaded parts are not stripped or crossthreaded. If parts are damaged, get new ones.

GO TO FRAME 3

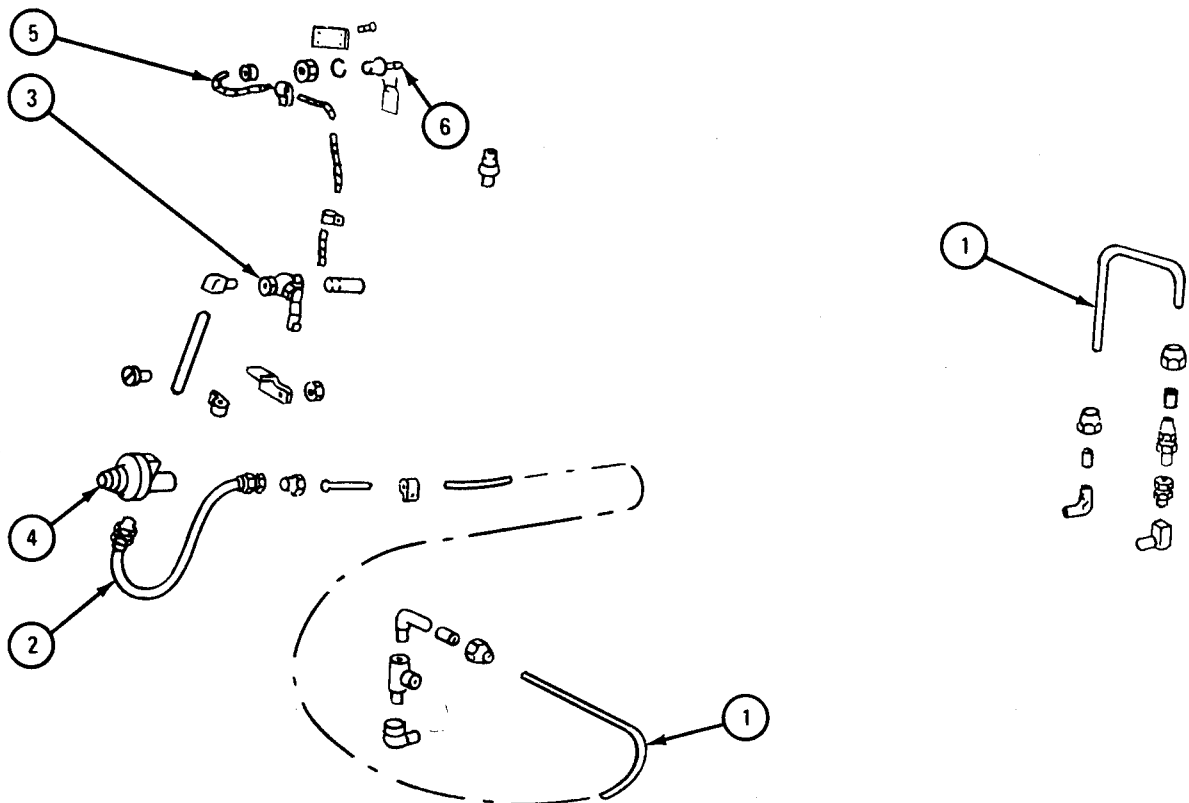

NOTE: CHECK ONLY THOSE PARTS WHICH ARE CALLED OUT IN THIS FRAME. PARTS WITHOUT CALLOUTS ARE SHOWN ONLY FOR REFERENCE PURPOSES OR ARE CHECKED IN ANOTHER FRAME.

TA 103301

FRAME 3

1. Check that all threaded parts are not stripped or crossthreaded. If parts are damaged, get new parts.
2. Check that upper exhaust extension (1) has no dents, bends, cracks or holes. If part is dented or bent, refer to FM 43-2. If parts has cracks or holes, refer to TM 9-237.
3. Check that weathercap (2) opens freely. If it does not, put on a coat of lubrication oil. If more repair is needed, get a new part.

GO TO FRAME 4

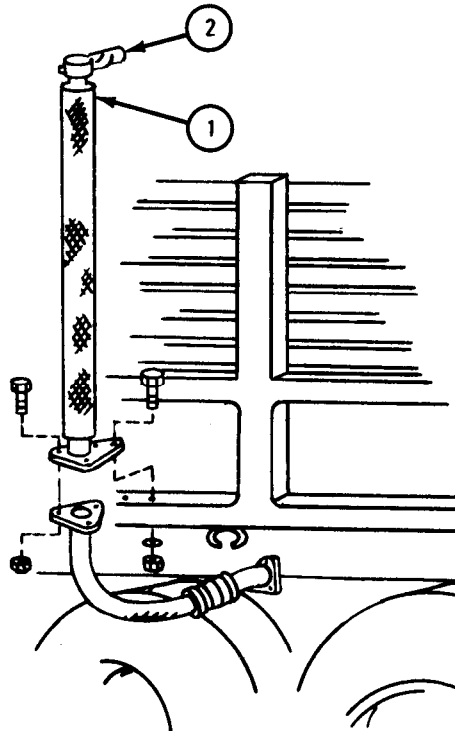

NOTE: CHECK ONLY THOSE PARTS WHICH ARE CALLED OUT IN THIS FRAME. PARTS WITHOUT CALLOUTS ARE SHOWN ONLY FOR REFERENCE PURPOSES OR ARE CHECKED IN ANOTHER FRAME.

TA 103302

FRAME 4

1. Check that cap (1), two clamps (2), two clamps (3), three clamps (4), and support (5) are not bent or dented. If parts are bent or dented, refer to FM 43-2. If more repair is needed, get a new part.
2. Check that hose (6) and two hoses (7) are not cracked or have any holes. If parts are damaged, get new parts.
3. Check that all threaded parts are not stripped, crossthreaded or damaged. If parts are damaged, get new parts.

END OF TASK

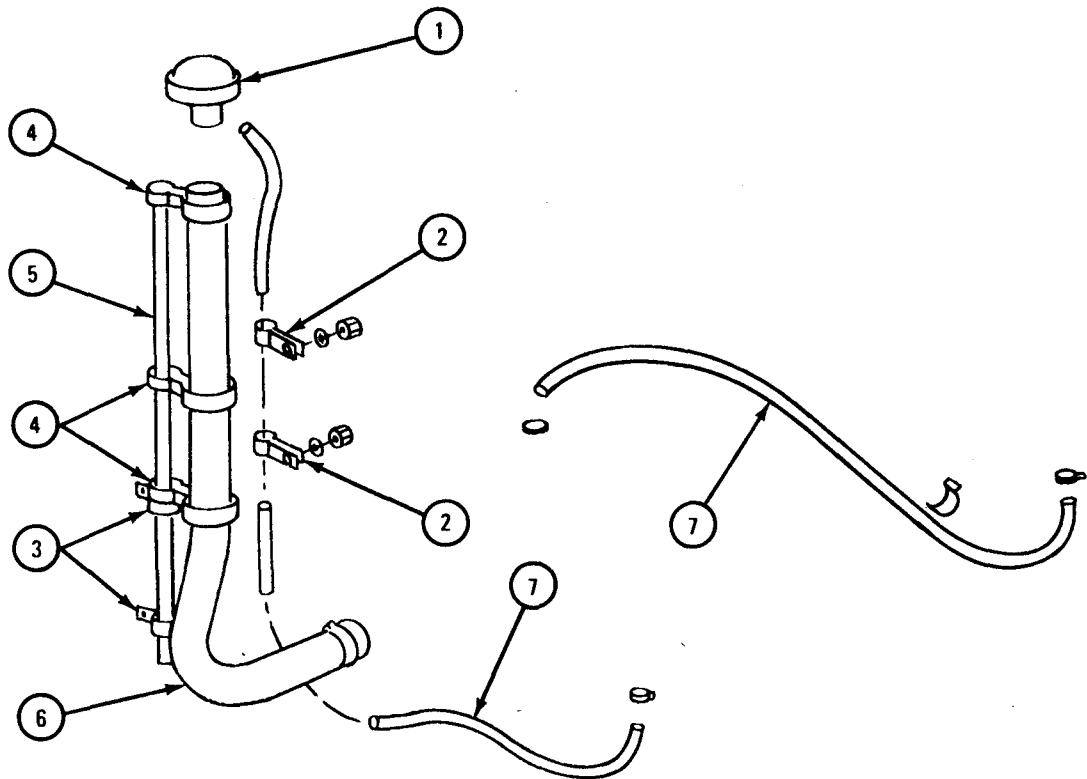

NOTE: CHECK ONLY THOSE PARTS WHICH ARE CALLED OUT IN THIS FRAME. PARTS WITHOUT CALLOUTS ARE SHOWN ONLY FOR REFERENCE PURPOSES OR ARE CHECKED IN ANOTHER FRAME.

TA 103303

FRAME 5

1. Check that cap (1), two halves of clamps (2), and two halves of clamp (3) are not bent or dented. If parts are bent or dented, refer to FM 43-2. If more repair is needed, get new parts.
2. Check that hose (4) and two hoses (5) are not cracked or have any holes. If parts are damaged, get new parts.
3. Check that all threaded parts are not stripped, crossthreaded or damaged. If parts are damaged, get new parts.

END OF TASK

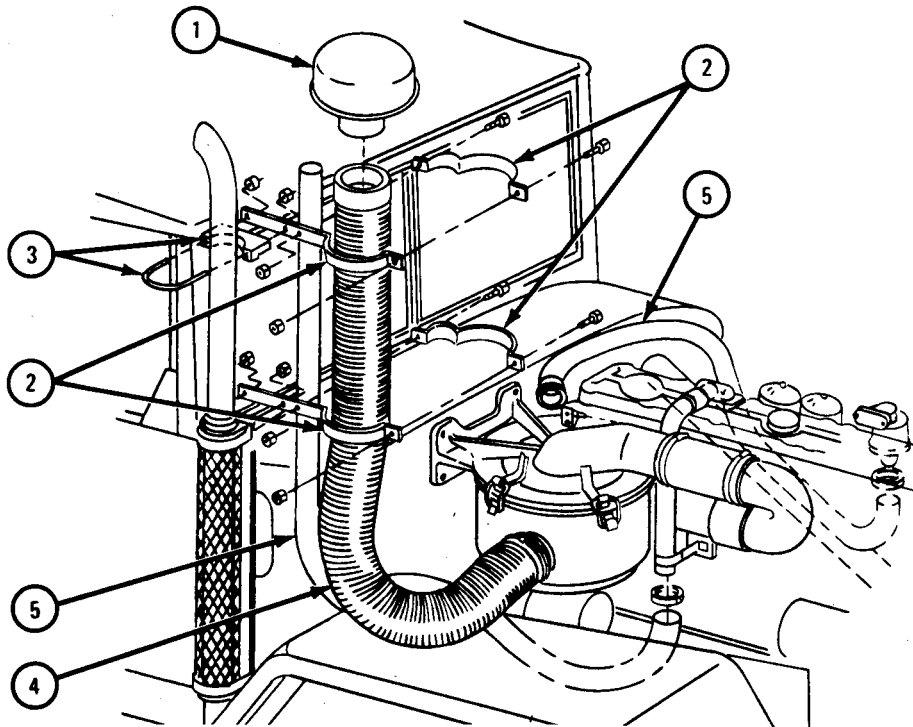

TA 103304

e. Replacement.

FRAME 1

- 1. Put in two screws (1).
- 2. Put on angle bracket (2) and two nuts (3).
- 3. Put in two screws (4).
- 4. Put on fording valve control lever (5) and two nuts (6).
- 5. Put in reducer (7), tee pipe (8), and reducer (9).
- 6. Put on tube (10).

GO TO FRAME 2

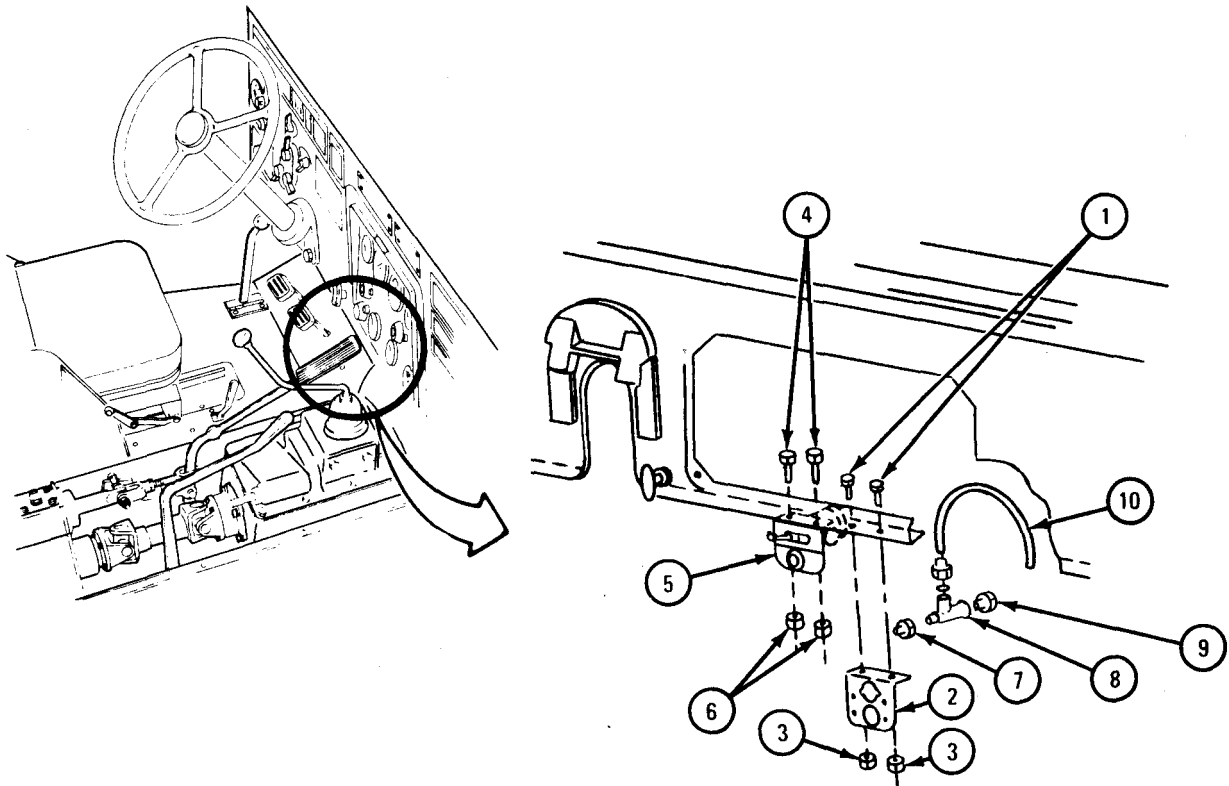

TA 103305

FRAME 2

1. Put on adapters (1 and 2).
2. Put on coupling (3) and washer (4).
3. Put on washer (5), nut (6), and nipple (7).
4. Put on tube (8) and elbow (9).

GO TO FRAME 3

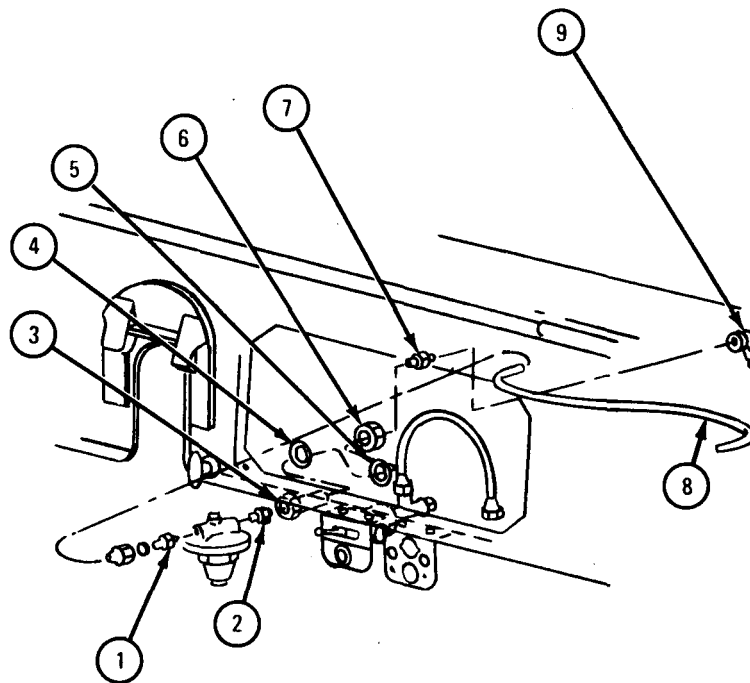

TA 103306

FRAME 3

1. Put on elbow (1), hose (2), band (3), and hose (4).

IF WORKING ON TRUCKS M35A1, OR M35A2, GO TO FRAME 4.

IF WORKING ON OTHER TRUCKS, GO TO FRAME 11

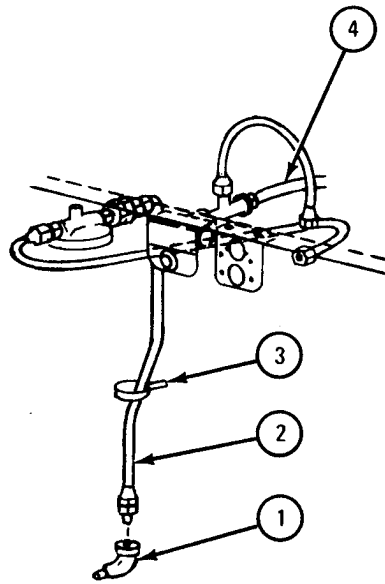

TA 103307

FRAME 4

1. Put in control switch (1).
2. Put on lockwasher (2), nut (3), and rubber grommet (4).
3. Put in pipe nipple (5), shutoff valve (6), elbow (7), nipple (8), and bracket (9).

GO TO FRAME 5

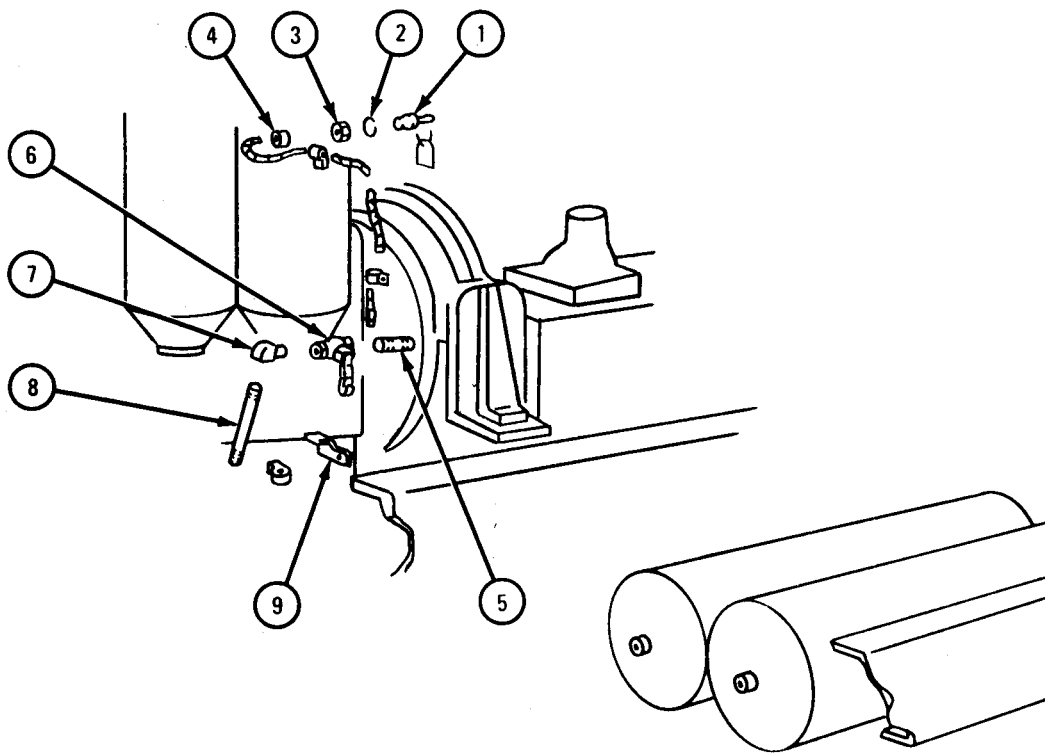

TA 103308

FRAME 5

1. Put in valve (1).
2. Put in three brackets (2) and control cable (3).
3. Put in screw (4) and put on nut (5).
4. Put on hose (6), tube (7), and bracket (8).

GO TO FRAME 6

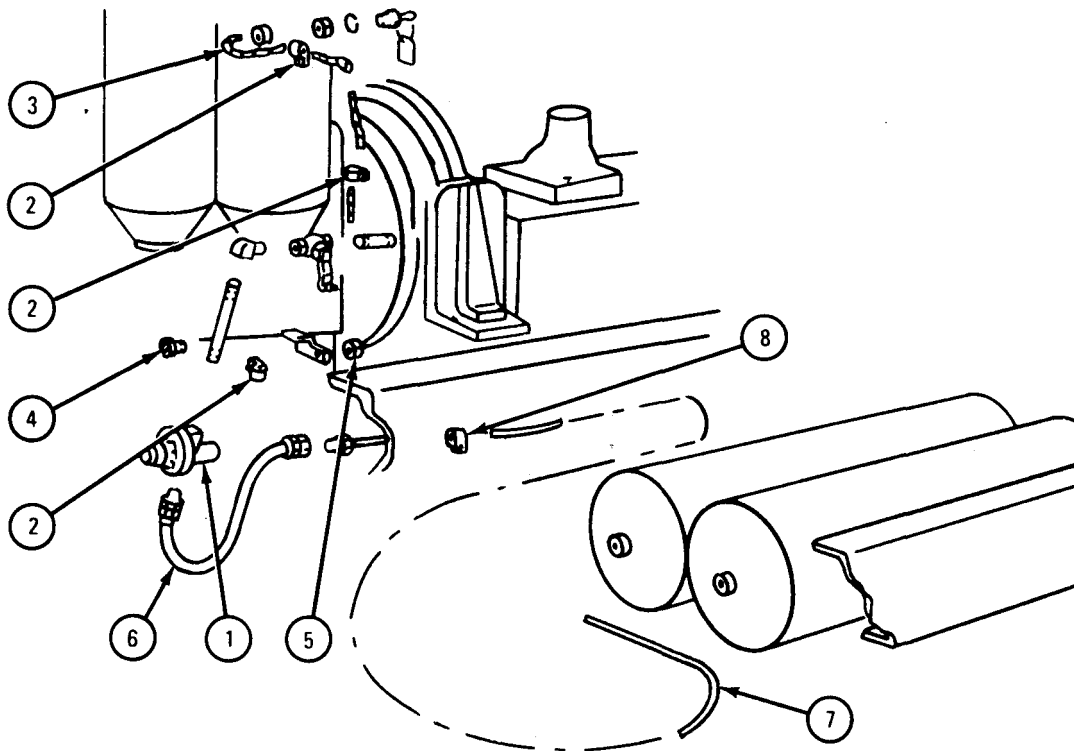

TA 103309

FRAME 6

1. Put on elbow (1), tee connection (2), elbow (3), and fitting (4).
2. Put on two line nuts (5).
3. Put on two elbows (6).
4. Put on valve (7) and connector (8).
5. Put in two fittings (9).
6. Put on two line nuts (10).

GO TO FRAME 7

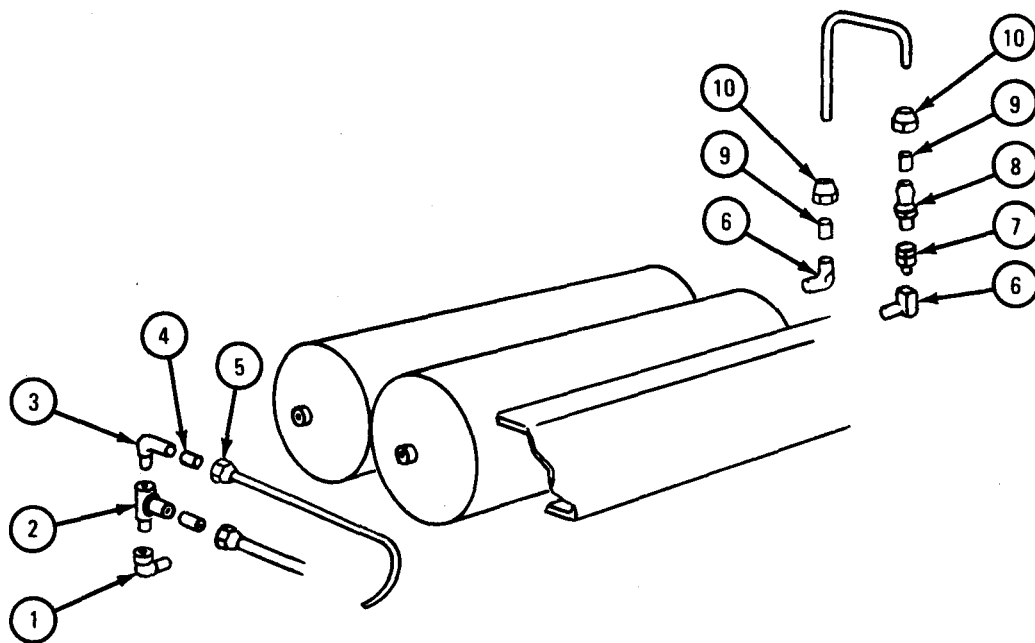

TA 103310

FRAME 7

1. Align gasket (1) with lower exhaust extension (2) and exhaust pipe (3).
2. Put in three screws (4) and put on three nuts (5).
3. Align gasket (6) with lower exhaust extension (2) and upper exhaust extension (7).
4. Put in four screws (8) and put on four nuts (9).

GO TO FRAME 8

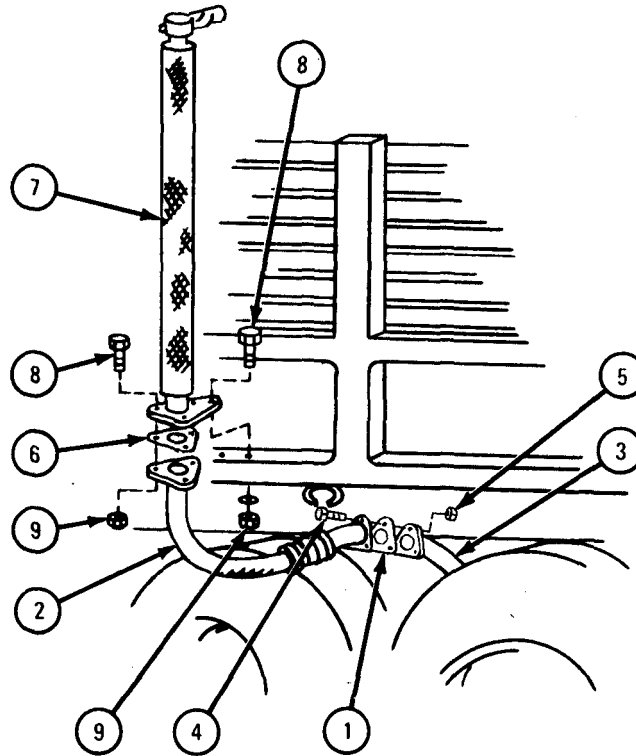

TA 103311

FRAME 8

1. Align holes in two brackets (1) with truck and put in two screws (2) and cotter pin (3).
 2. Put on three brackets (4) and tube (5).
 3. Put in three screws (6) and put on three washers (7) and nuts (8).
- GO TO FRAME 9

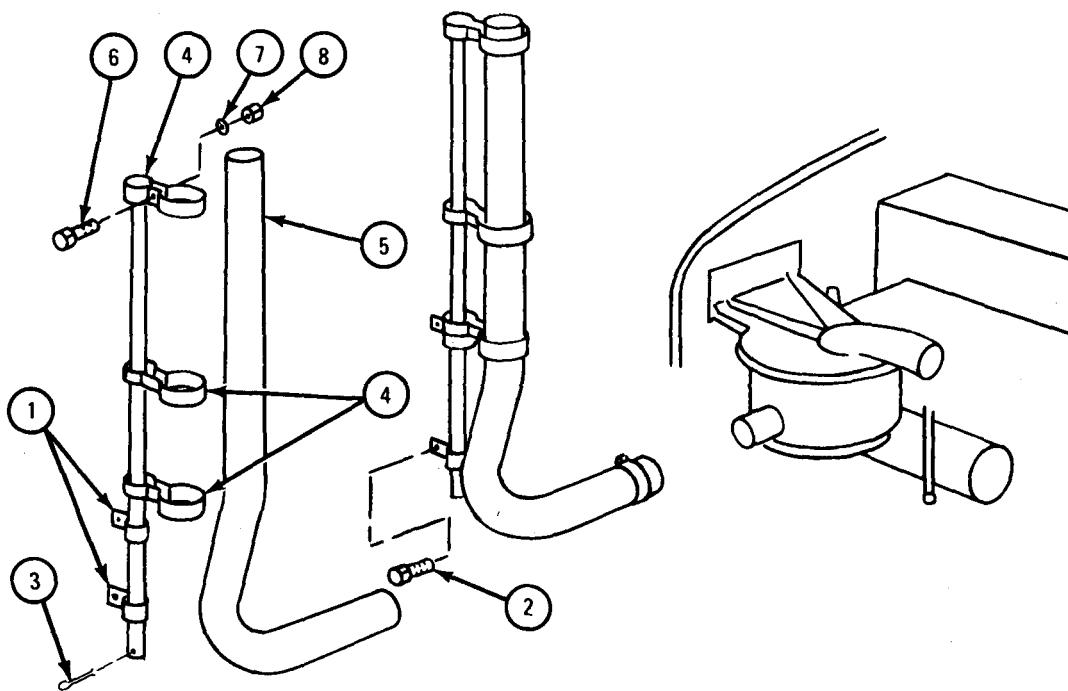

TA 103312

FRAME 9

1. Put two clamps (1) around hose (2).
2. Put on two clamps (1), washers (3), and nuts (4).
3. Put on hose (2) and clamp (5).
4. Put on hose (6) and two clamps (7).
5. Put on strap (8).

GO TO FRAME 10

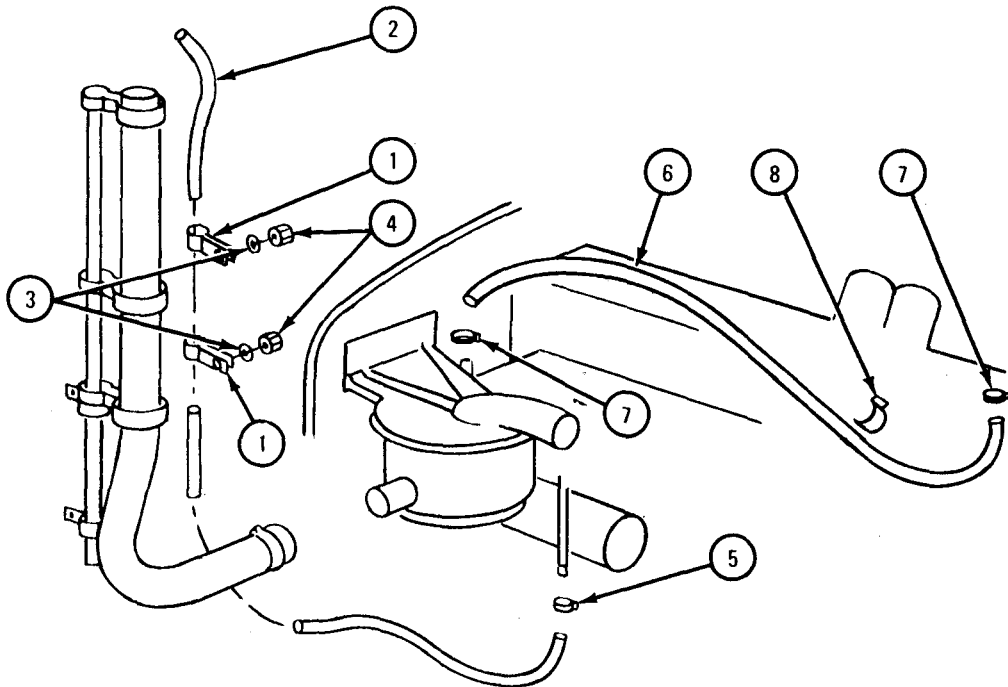

TA 103313

FRAME 10

Put tube (1) through side panel (2).

Put clamp (3) on tube (1) and put on tube.

Put on cap (4).

NOTE

Follow-on Maintenance Action Required:

1. Put in transmission breather. Refer to TM 9-2320-209-20.
2. Put in control valve. Refer to TM 9-2320-209-20.
3. Close hood and left side panel. Refer to TM 9-2320-209-10.

END OF TASK

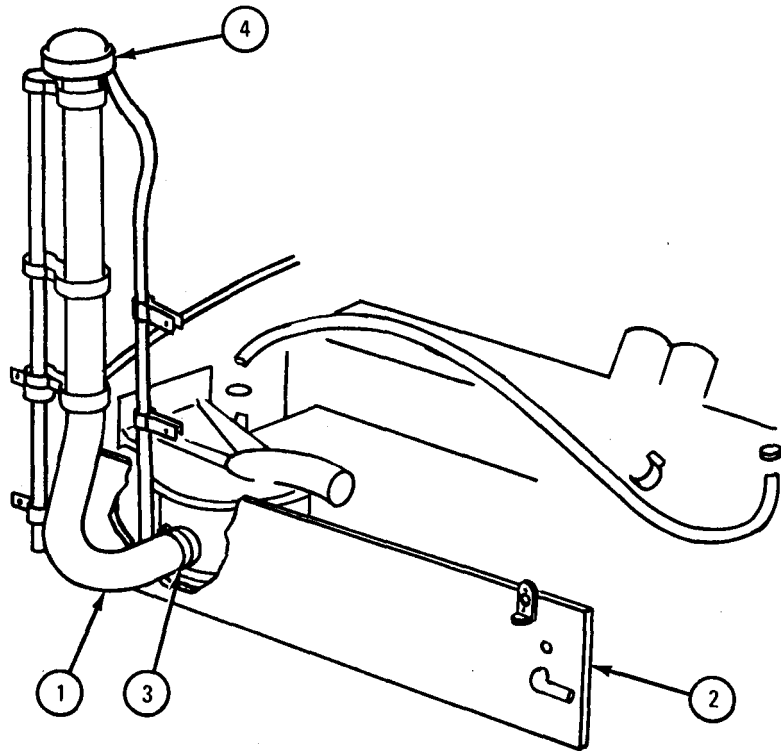

TA 103314

FRAME 11

- 1. Put on hose (1), two clamps (2), and strap (3).
- 2. Put on clamp (4), two halves of two clamps (5), and four nuts (6).
- 3. Put two tubes (7 and 8) and both halves of two clamps (5) in place and put in four screws (9).
- 4. Put on four nuts (10).

GO TO FRAME 12

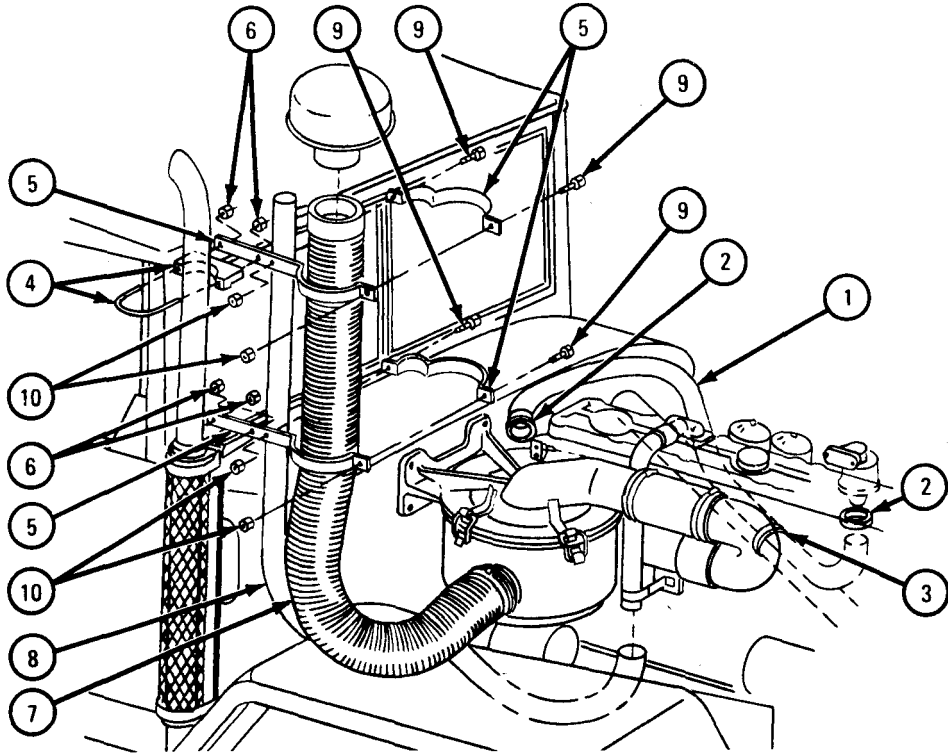

TA 103315

FRAME 12

1. Put on tube (1) and clamp (2).
2. Put on cap (3).

NOTE

Follow-on Maintenance Action Required

1. Put in transmission breather. Refer to TM 9-2320-209-20.
2. Put in control valve. Refer to TM 9-2320-209-20.
3. Close hood and left side panel. Refer to TM 9-2320-209-10.

END OF TASK

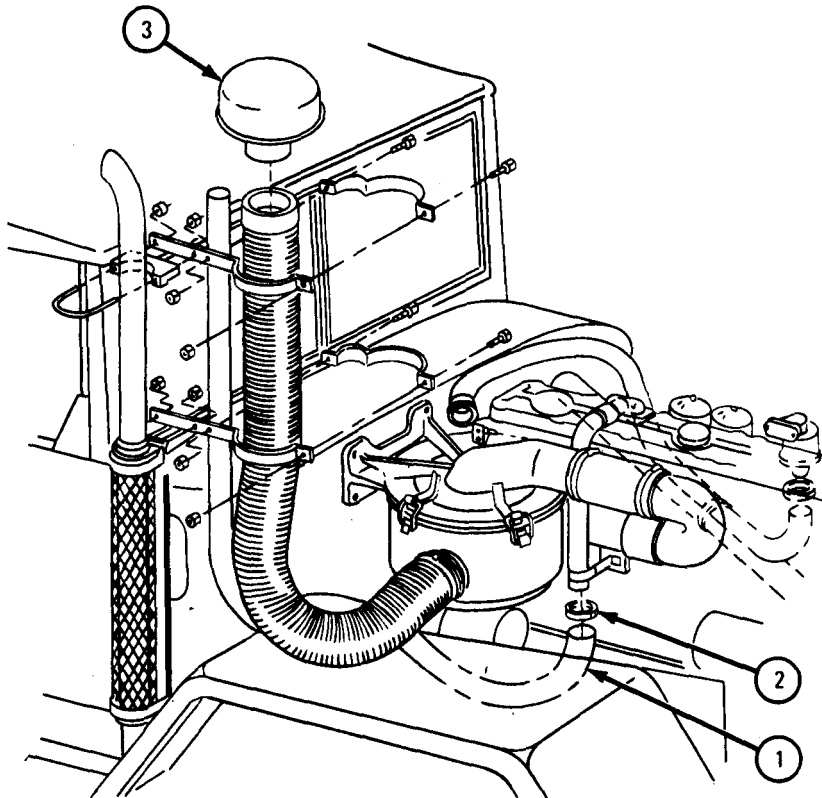

TA 103316

21-22. DEEP WATER FORDING AIR PRESSURIZING SYSTEM SHUTOFF VALVE
REMOVAL AND REPLACEMENT.

TOOLS: No special tools required

SUPPLIES: None

PERSONNEL: One

EQUIPMENT CONDITION: Truck parked, engine off and cool, handbrake set.

a. Removal.

FRAME 1

1. Pull up on each hood hold down latch (1) until it clears each hood catch (2).
2. Push and hold in hood latch (3).
3. Lift hood (4) and let go of hood latch (3).

GO TO FRAME 2

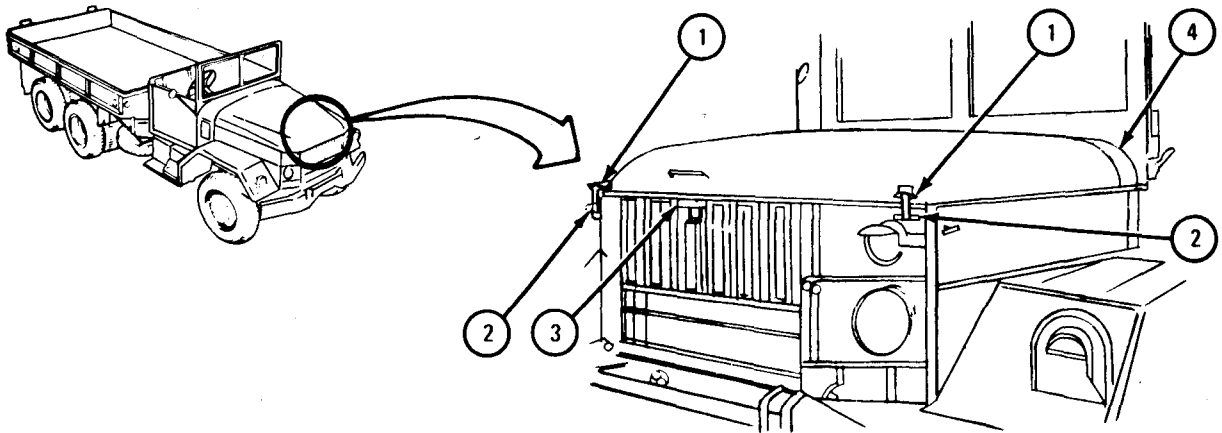

TA 089048

FRAME 2

1. Raise hood (1) to position shown.
 2. Pull hood support hook (2) out of storage clip (3).
 3. Swing hood support hook (2) up and join support hook with latch (4) as shown.
- GO TO FRAME 3

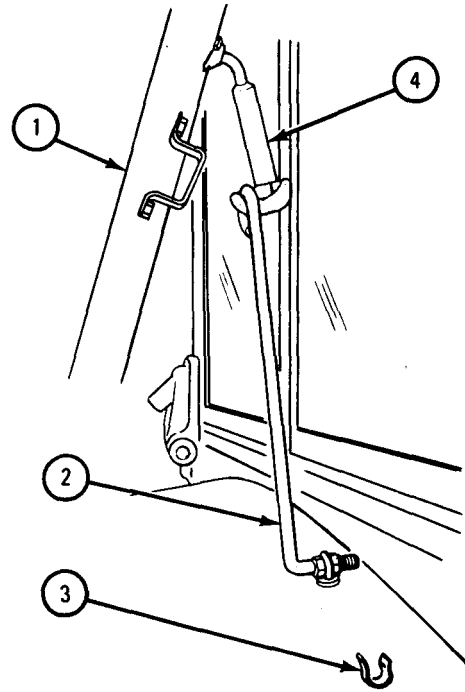
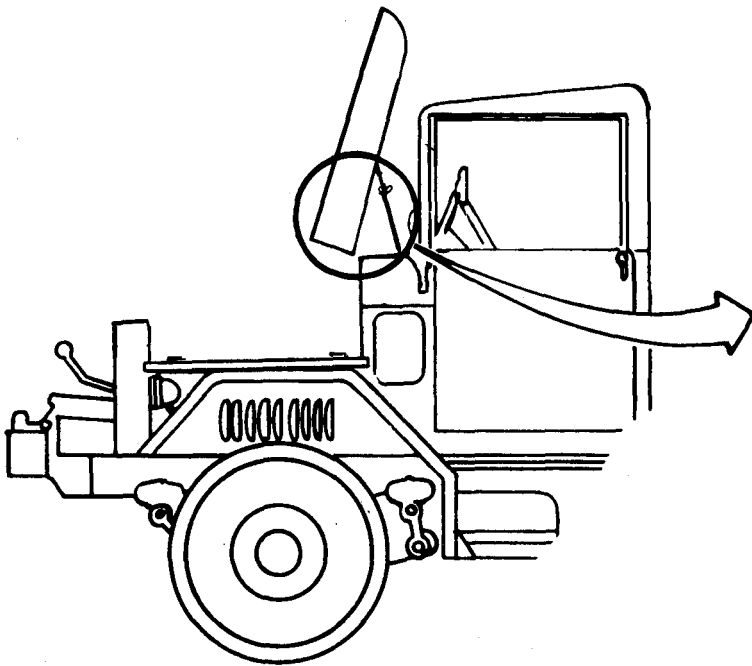

TA 089049

FRAME 3

1. Take off nut (1).
 2. Take hose (2) off valve (3).
 3. Take valve (3) off nipple (4).
- GO TO FRAME 4

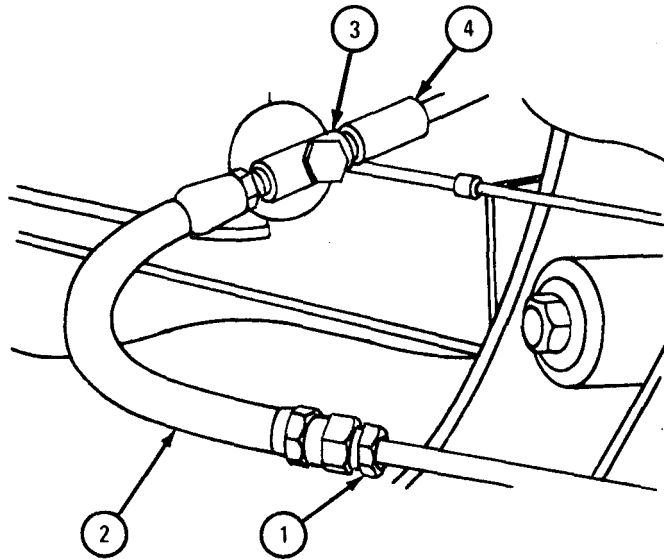

TA 089059

FRAME 4

1. Take off control cable (1).
2. Take off nut (2) and take out screw (3) with washer (4).
3. Take clamp (5) off nipple (6).
4. Take nipple (6) out of inlet elbow (7).
5. Take inlet elbow (7) off shutoff valve (8).
6. Take shutoff valve (8) off flywheel housing nipple (9).

END OF TASK

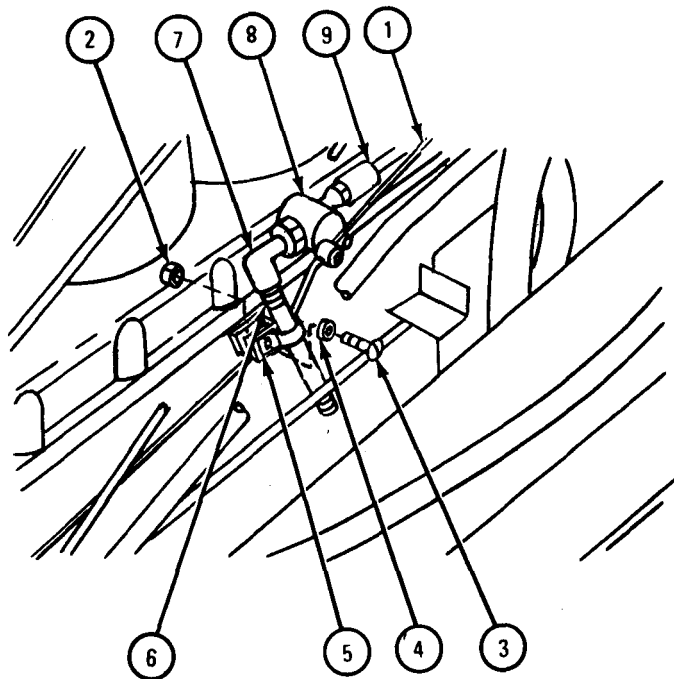

TA 089060

b. Replacement.

FRAME 1

1. Put shutoff valve (1) on nipple (2) with operating arm (3) facing down.
2. Put inlet elbow (4) in shutoff valve (1).
3. Put nipple (5) in inlet elbow (4).
4. Put clamp (6) on nipple (5).
5. Put screw (7) and washer (8) through clamp (6) and bracket (9). Put on nut (10).

GO TO FRAME 2

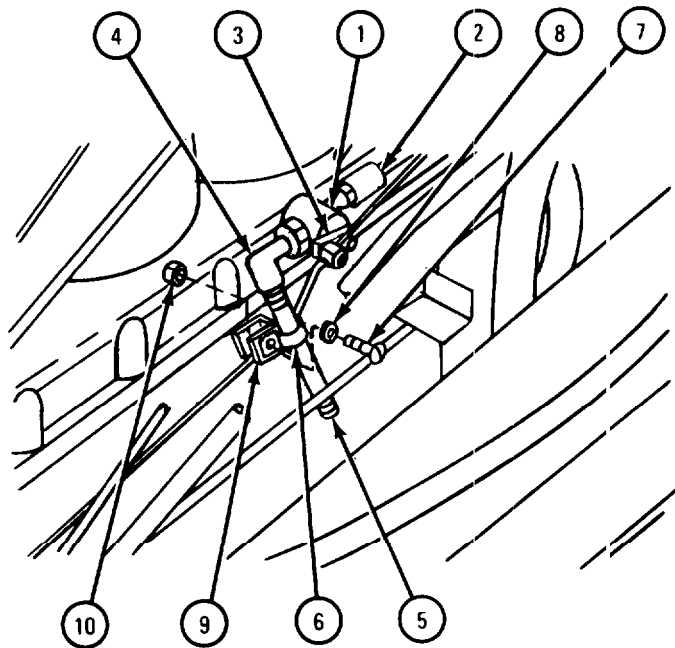

TA 089061

FRAME 2

1. Put control cable (1) through hole in nut (2).
2. Pull cable (1) taut and put in locking screw (3).

GO TO FRAME 3

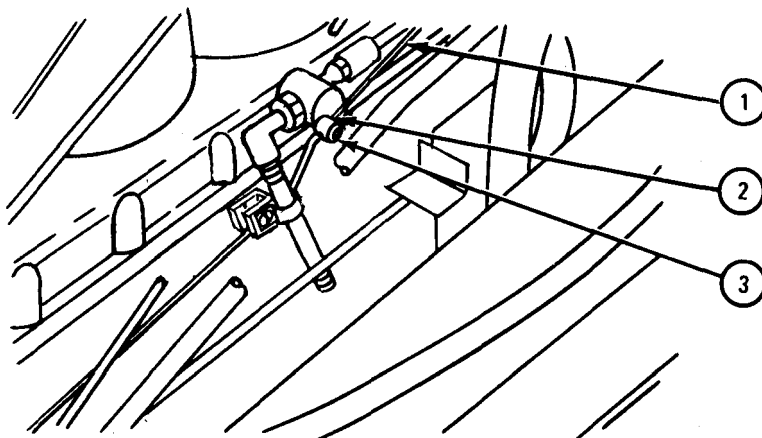

TA 089062

FRAME 3

1. Put regulator valve (1) onto nipple (2).
2. Put hose (3) on valve (1).
3. Put hose (3) on tube (4) and tighten nut (5).

GO TO FRAME 4

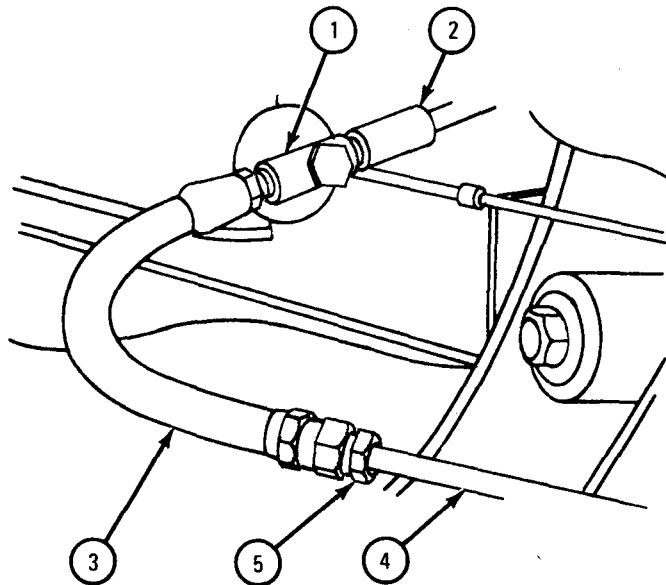

TA 089063

FRAME 4

1. Push back on hood (1) so that latch (2) clears support hook (3).
 2. Hold hood (1) and swing support hook (3) down into storage clip (4).
 3. Lower hood (1).
- GO TO FRAME 5

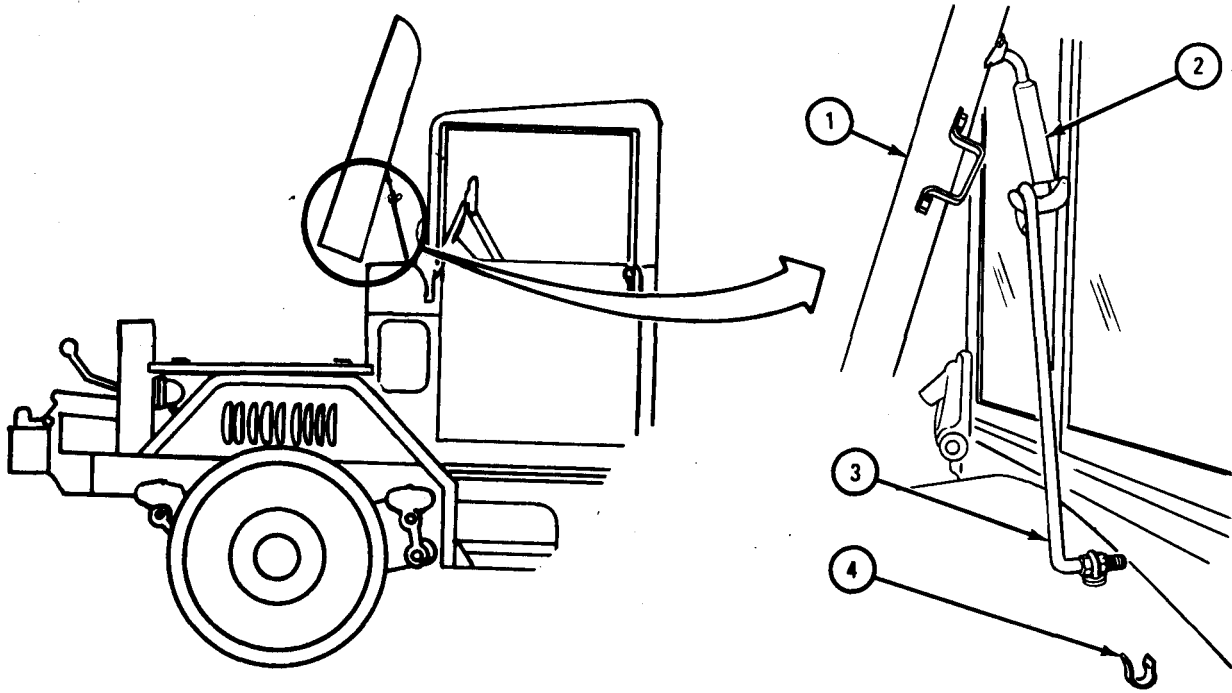

TA 089055

FRAME 5

1. Push down on hood (1) to lock hood latch (2).
2. Pull up on each hood hold down latch (3) and join them to hood catches (4).

END OF TASK

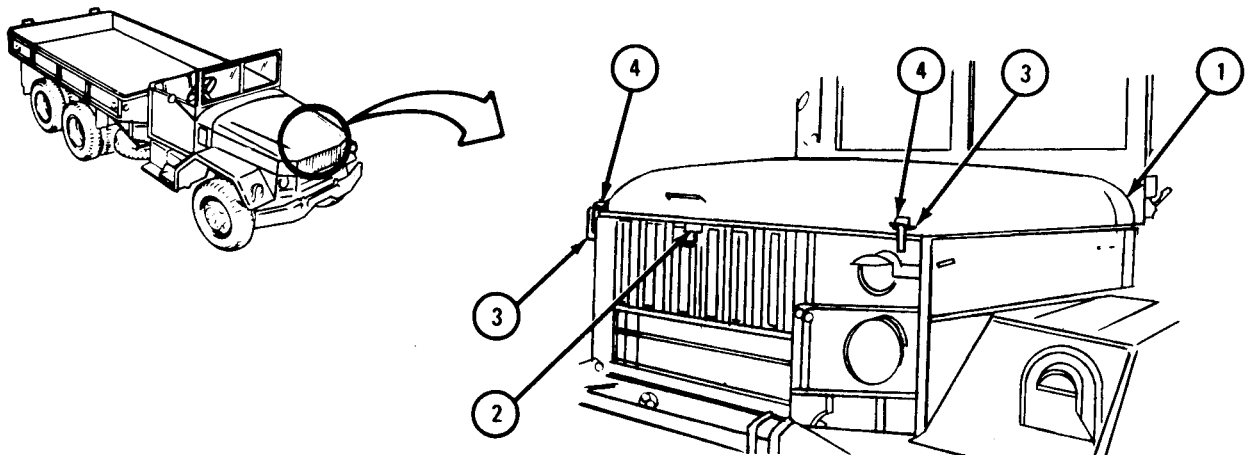

TA 089056

21-23. DEEP WATER FORDING AIR PRESSURIZING SYSTEM REGULATOR VALVE
REMOVAL AND REPLACEMENT.

TOOLS: No special tools required

SUPPLIES: None

PERSONNEL: One

EQUIPMENT CONDITION: Truck parked, engine off and cool, handbrake set.

- a. Preliminary Procedure. Open hood. Refer to TM 9-2320-209-10.
- b. Removal.

FRAME 1

- 1. Unscrew nut (1).
- 2. Take off hose (2) from valve inlet,(3).
- 3. Take out valve outlet (4) from nipple (5).

GO TO FRAME 2

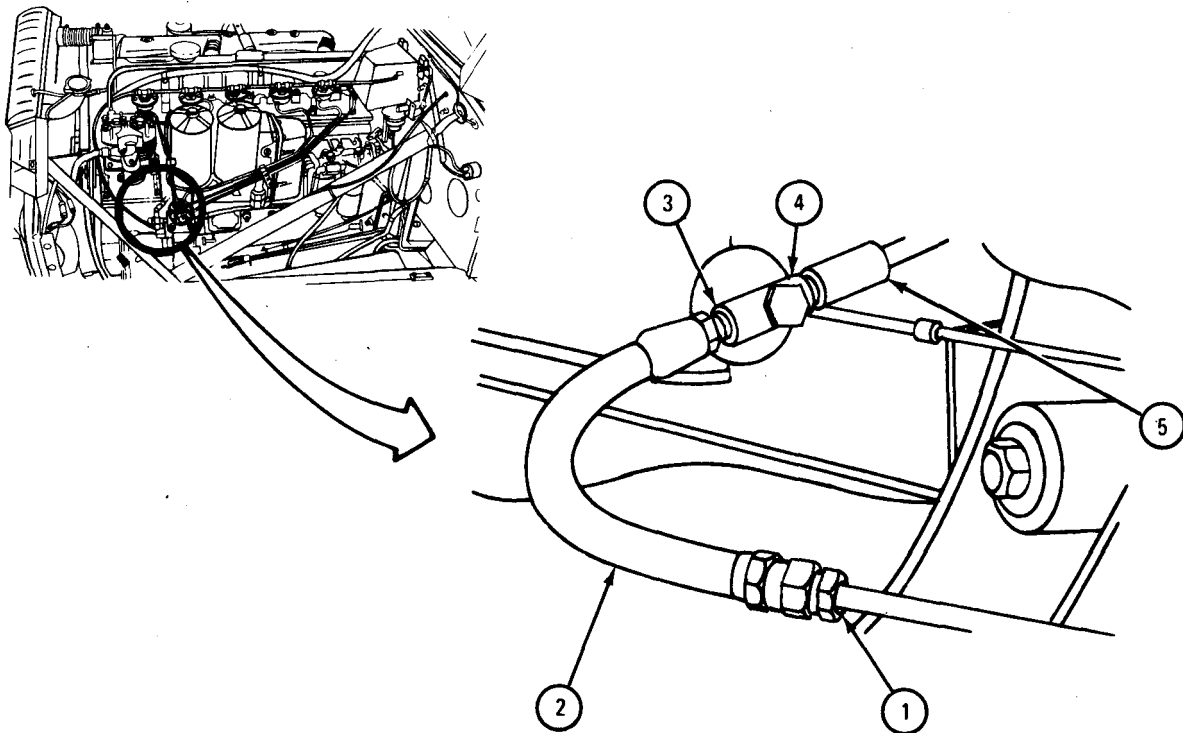

TA 089050

FRAME 2

1. Take off nut (1) and take out screw (2) and washer (3) from bracket (4) and clamp (5).
2. Take clamp (5) off nipple (6).
3. Take nipple (6) out of valve elbow (7).

END OF TASK

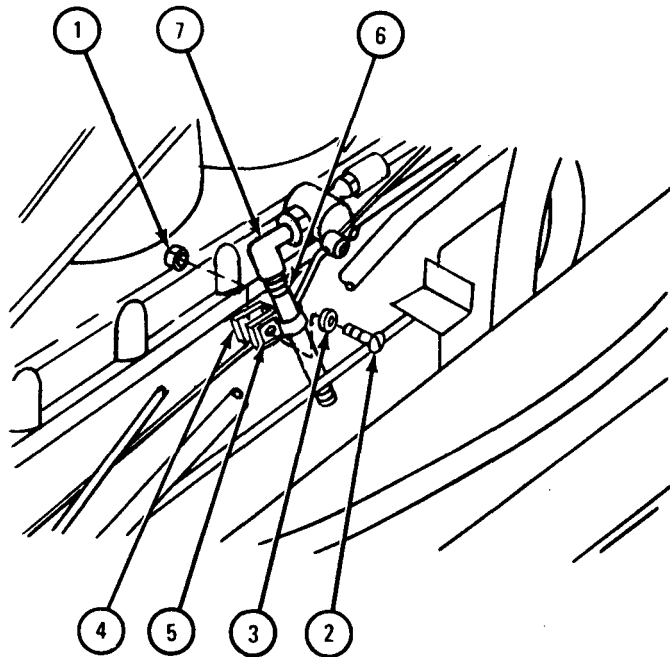

TA 089051

c. Replacement.

FRAME 1

1. Put nipple (1) into valve elbow (2).
2. Put clamp (3) over nipple (1).
3. Put screw and washer (4) through clamp (3) and bracket (5). Put on nut (6).

GO TO FRAME 2

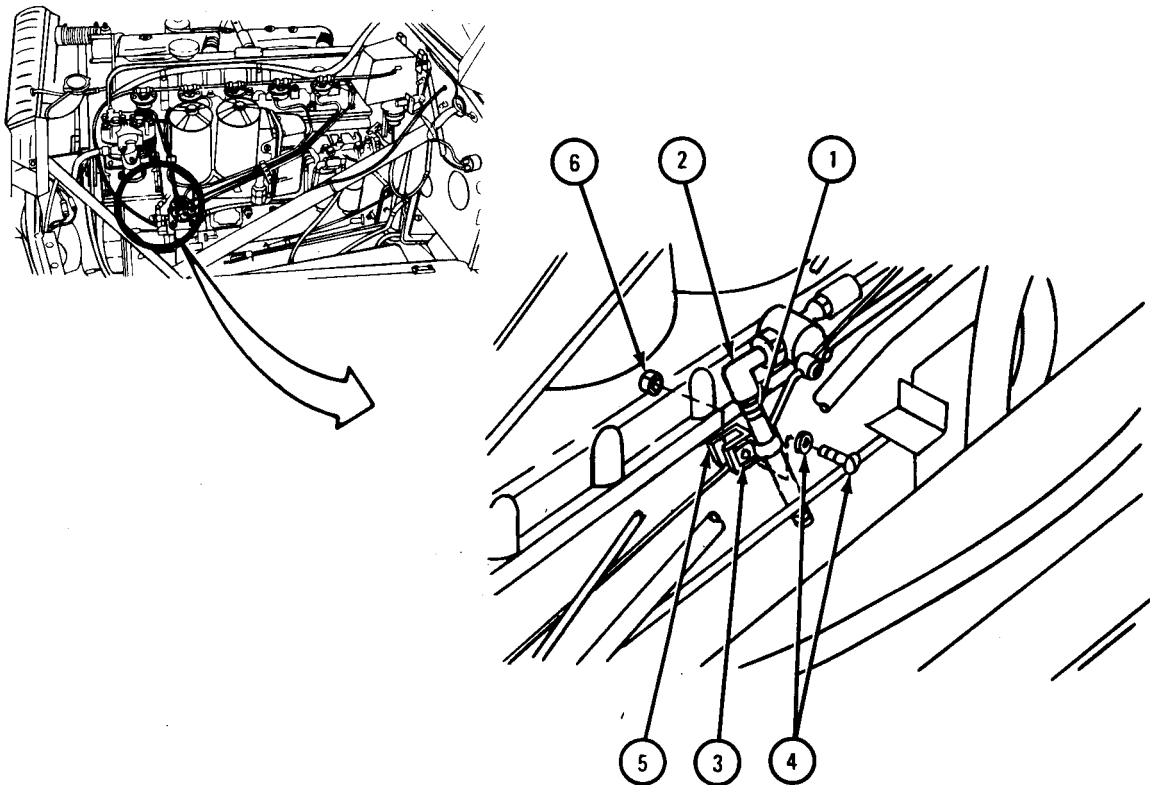

TA 089052

FRAME 2

1. Loosen jamnut (1) and unscrew adjusting screw (2) until it is free of spring seat (3).
2. Slowly tighten adjusting screw (2) until it touches spring seat (3). Tighten adjusting screw 1/4 turn more and tighten jamnut (1).

GO TO FRAME 3

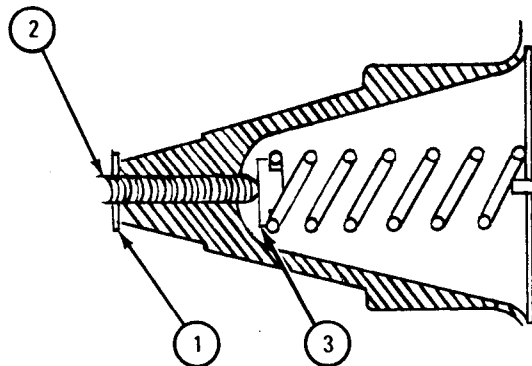

TA 089053

FRAME 3

1. Put regulator valve (1) onto nipple (2).
2. Put hose (3) into valve inlet (4).
3. Tighten nut (5).

NOTE

Follow-on Maintenance Action Required:
Close hood. Refer to TM 9-2320-209-10.

END OF TASK

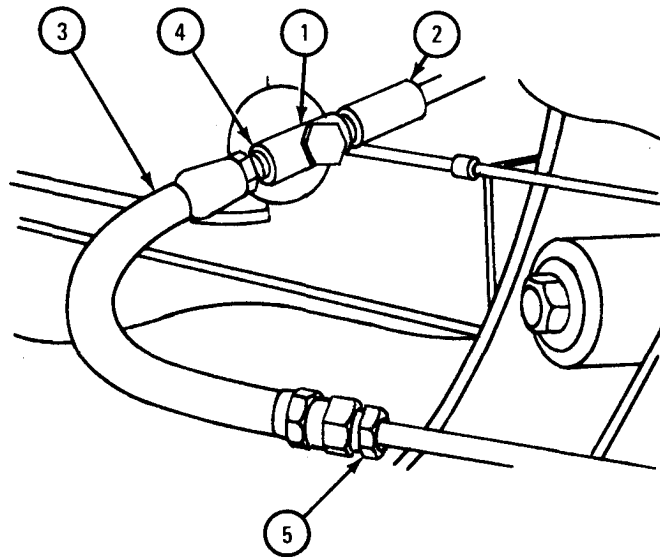

TA 089054

21-24. DEEP WATER FORDING AIR PRESSURIZING SYSTEM HOSE REMOVAL AND REPLACEMENT (TRUCKS M35A1 AND M35A2).

TOOLS: No special tools required

SUPPLIES: None

PERSONNEL: One

EQUIPMENT CONDITION: Truck parked, engine off and cool, handbrake set.

a. Removal.

FRAME 1

1. Pull up on each hood holddown latch (1) until they clear each hood catch (2).
2. Push and hold in hood latch (3).
3. Lift hood (4) and let go of hood latch (3).

GO TO FRAME 2

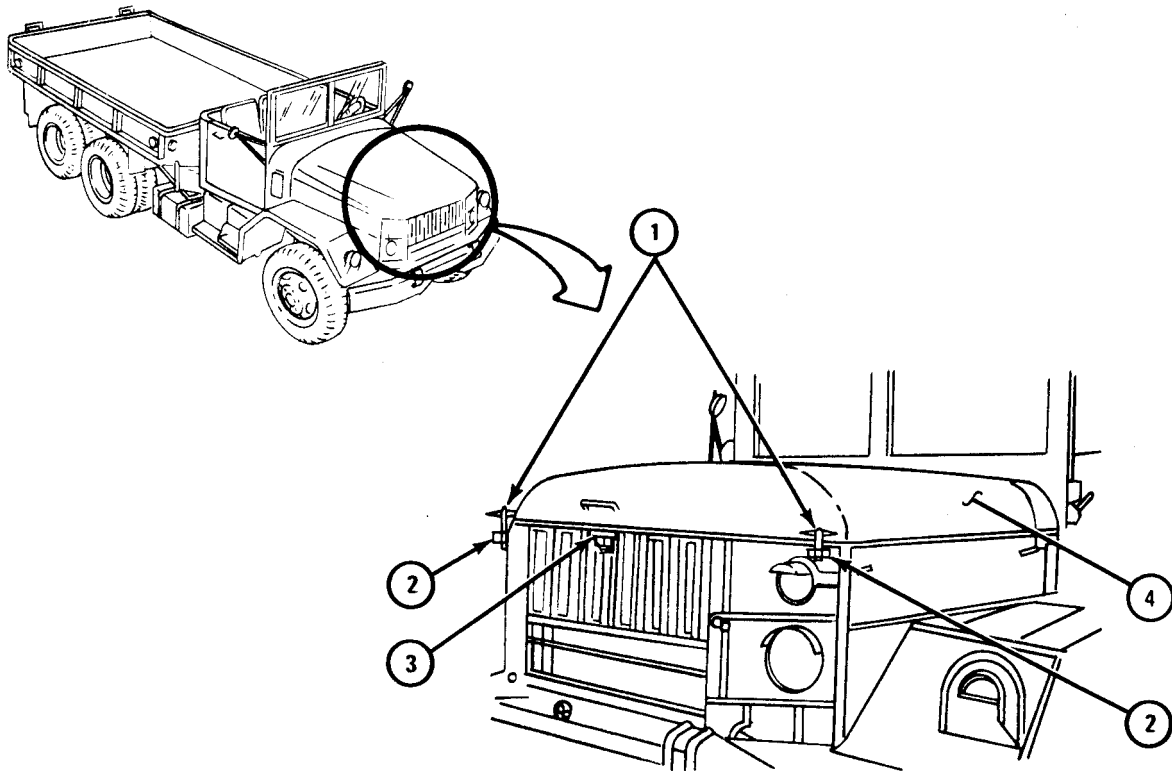

TA 089042

FRAME 2

1. Raise hood (1) to position shown.
2. Pull hood support hook (2) out of storage clip (3).
3. Swing hood support hook (2) up and join support hook with latch (4) as shown.

GO TO FRAME 3

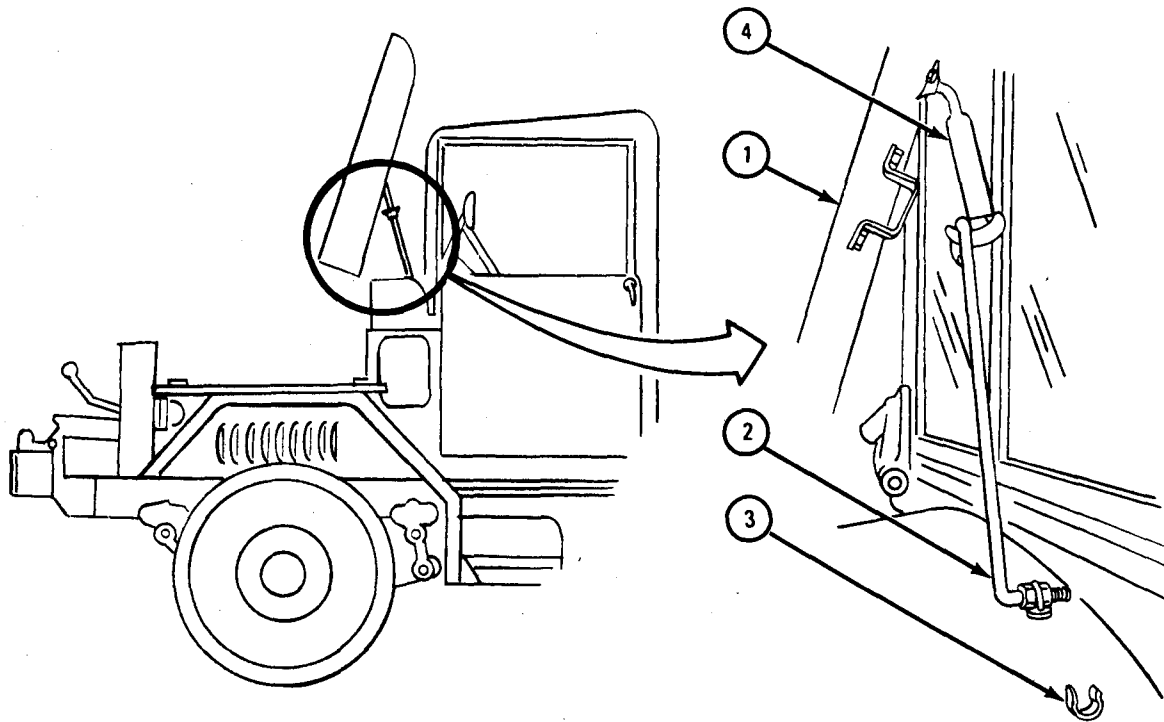

TA 089043

FRAME 3

1. Take off nut (1).
2. Unscrew hose (2) from valve inlet (3).

END OF TASK

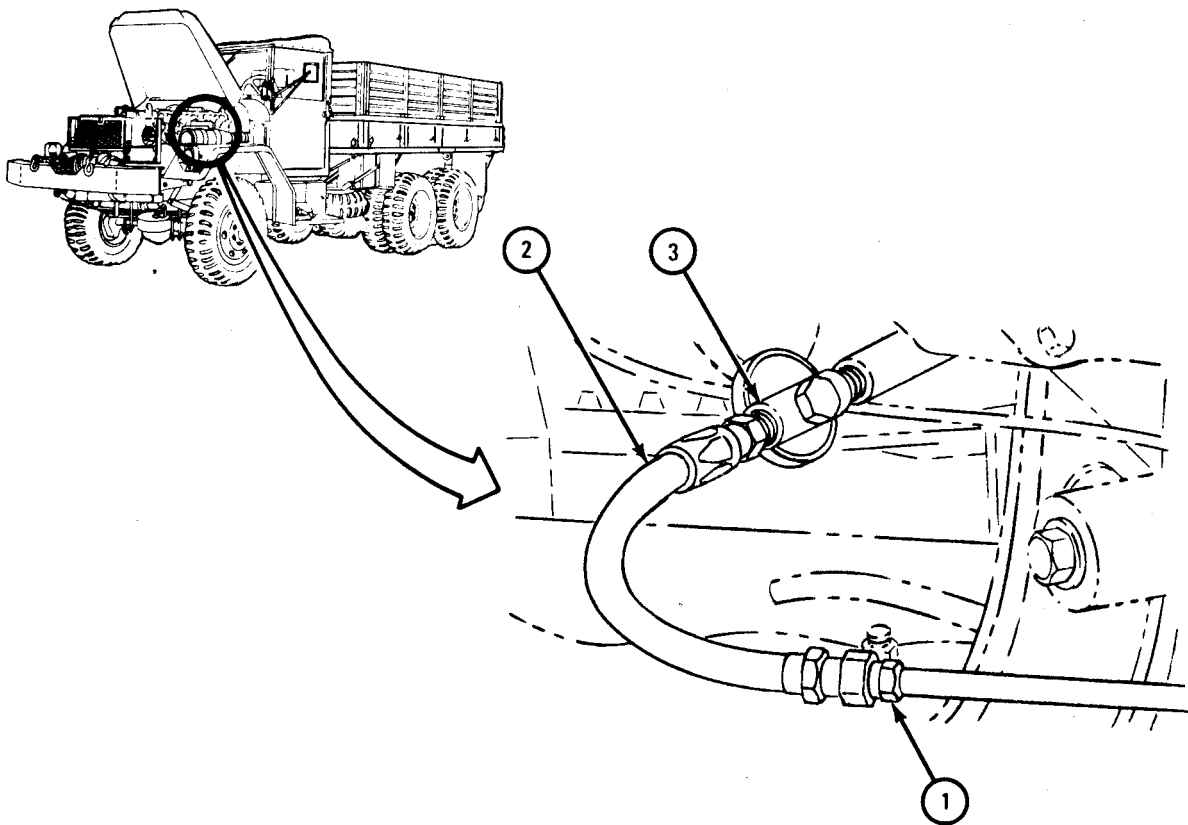

TA 089044

b. Replacement.

FRAME 1

1. Screw hose (1) into valve inlet (2).
 2. Tighten nut (3).
- GO TO FRAME 2

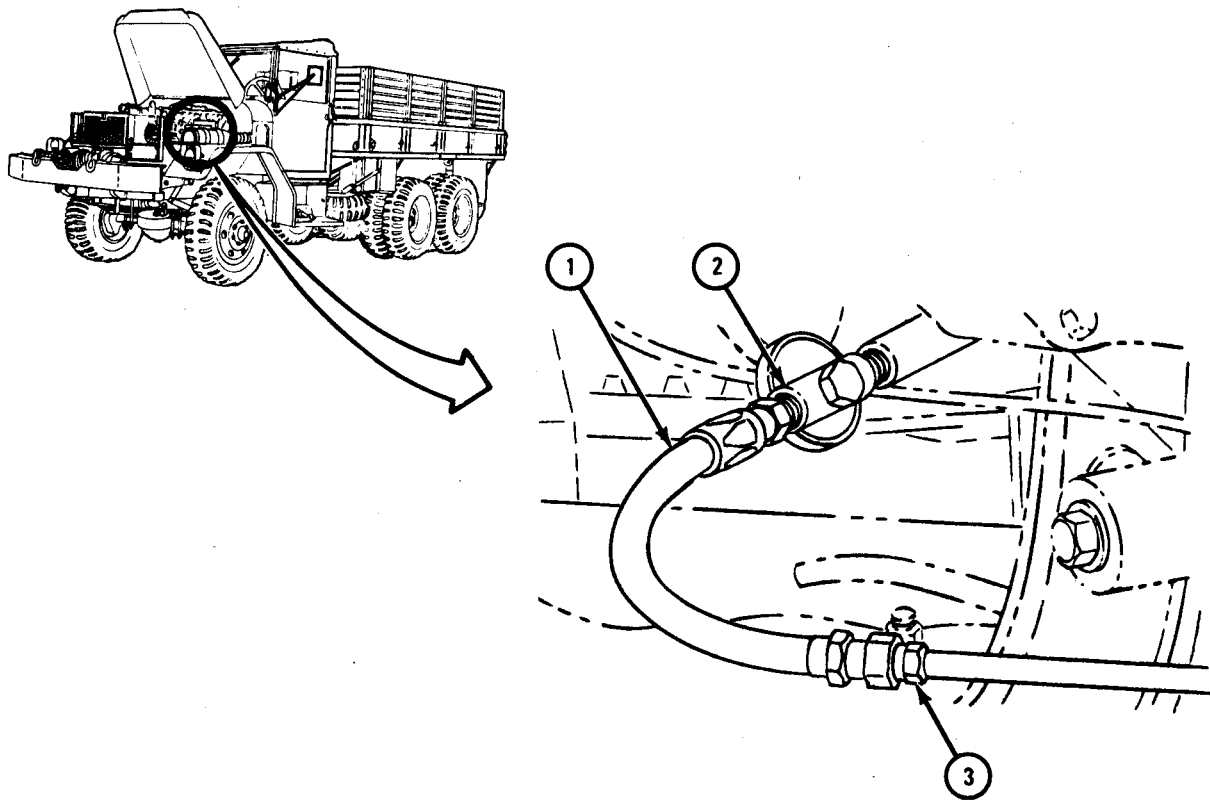

TA 089045

FRAME 2

1. Push back on hood (1) so that latch (2) clears support hook (3).
 2. Hold hood (1) and swing support hook (3) down into storage clip (4).
 3. Lower hood (1).
- GO TO FRAME 3

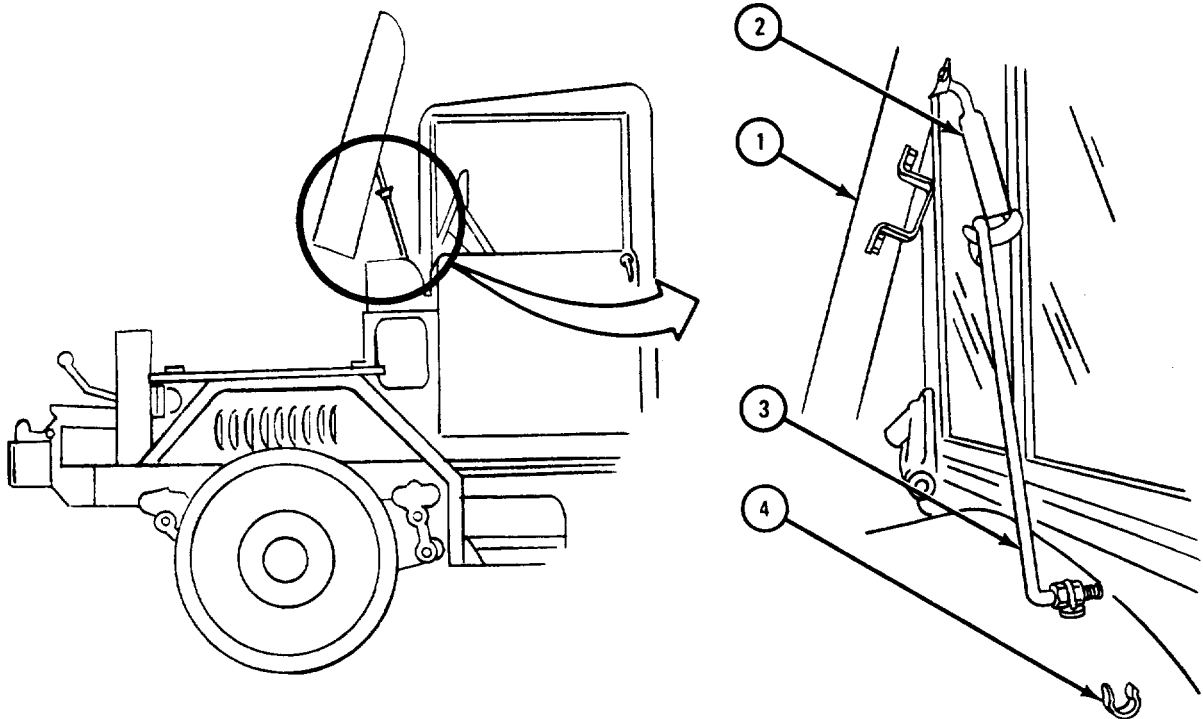

TA 089046

FRAME 3

1. Push down on hood (1) to lock hood latch (2).
 2. Pull up on each hood hold down latch (3) and join them to hood catches (4).
- END OF TASK

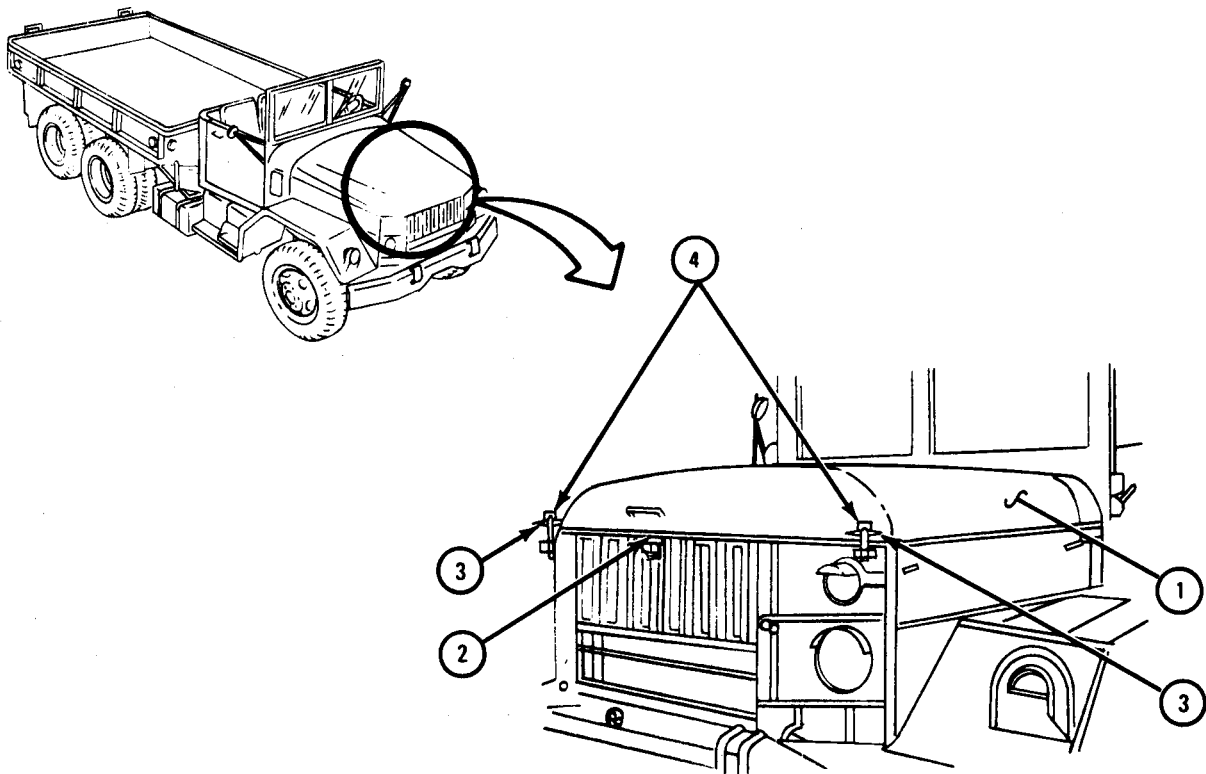

TA 089047

21-25. DEEP WATER FORDING EXHAUST EXTENSION GASKET REMOVAL AND REPLACEMENT.

TOOLS: No special tools required

SUPPLIES: Exhaust extension gasket

PERSONNEL: One

EQUIPMENT CONDITION: Truck parked, engine off, handbrake set.

a. Removal.

FRAME 1

1. Take off three nuts (1) and three screws with washers (2).
 2. Take off lower exhaust extension (3) and gasket (4). Throw away gasket.
- END OF TASK

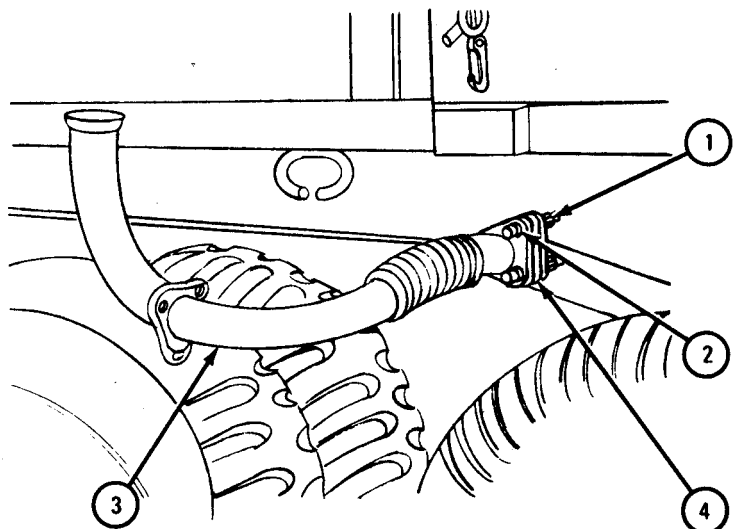
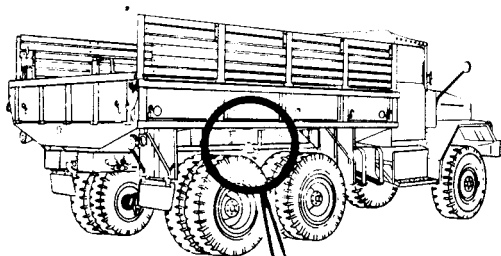

TA 089066

b. Replacement.

FRAME 1

1. Put in gasket (1) and put on lower exhaust extension (2).
2. Put in three screws with washers (3) and put on three nuts (4).

END OF TASK

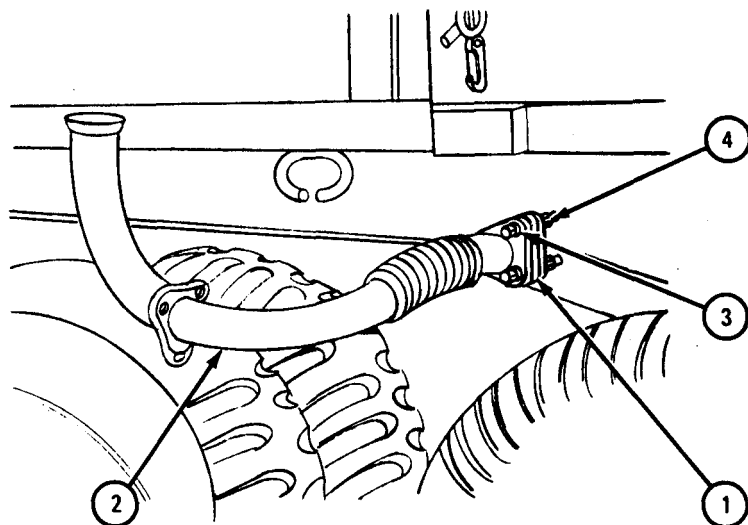
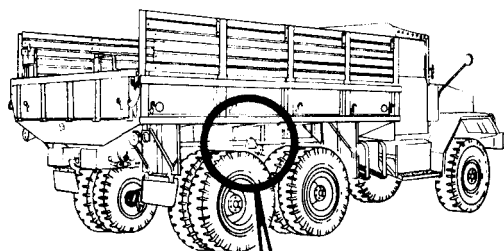

TA 089067

Section IV. SPECIAL PURPOSE KITS

21-26. DECONTAMINATION APPARATUS MOUNTING BRACKET INSTALLATION.

TOOLS: No special tools required

SUPPLIES: None

PERSONNEL: One

EQUIPMENT CONDITION: Truck parked, engine off, handbrake set.

FRAME 1

1. Slide rubber boot (1) up gearshift lever (2) as shown.
2. Take off nut with flat washer (3). Take out bolt (4) and lift off gearshift lever (2).

GO TO FRAME 2

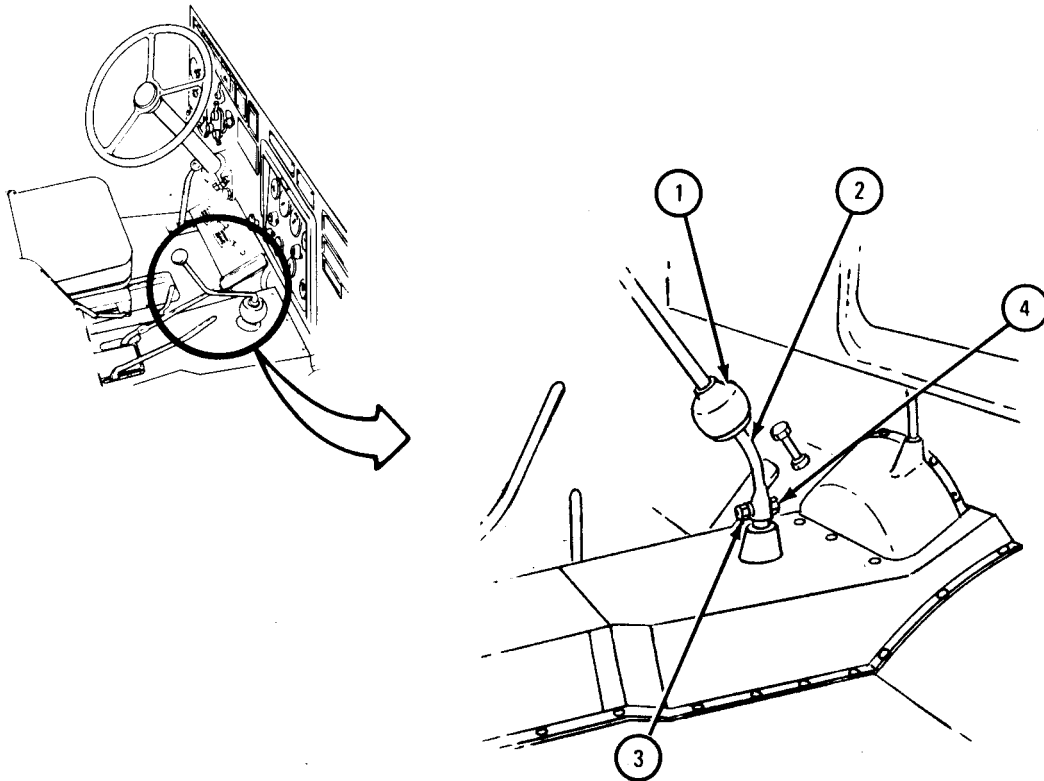

TA 103456

FRAME 2

1. Take out 13 screws (1) holding intermediate tunnel (2) to front tunnel (3), cab floor (4), and rear tunnel (5).
 2. Lift off intermediate tunnel (2) and take it out of cab.
- GO TO FRAME 3

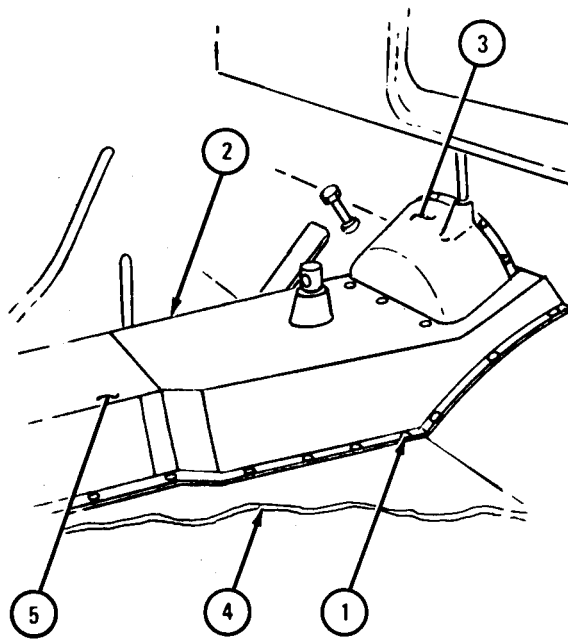

TA 103457

FRAME 3

1. Find center of transmission gearshift lever hole (1).
2. Measure 3.25 inches from center of transmission gear shift lever hole (1) to point A and mark as shown.
3. Measure 1.75 inches from point A to point B and mark as shown.
4. Measure 2.75 inches from point B to point C and mark as shown.
5. Measure 4.00 inches from center of transmission gearshift lever hole (1) to point D and mark as shown.
6. Measure 3.25 inches from point D to point E and mark as shown.
7. Measure 2.50 inches from point E to point F and mark as shown.
8. Drill 0.218 inch diameter hole at points, B, C, E, and F.

GO TO FRAME 4

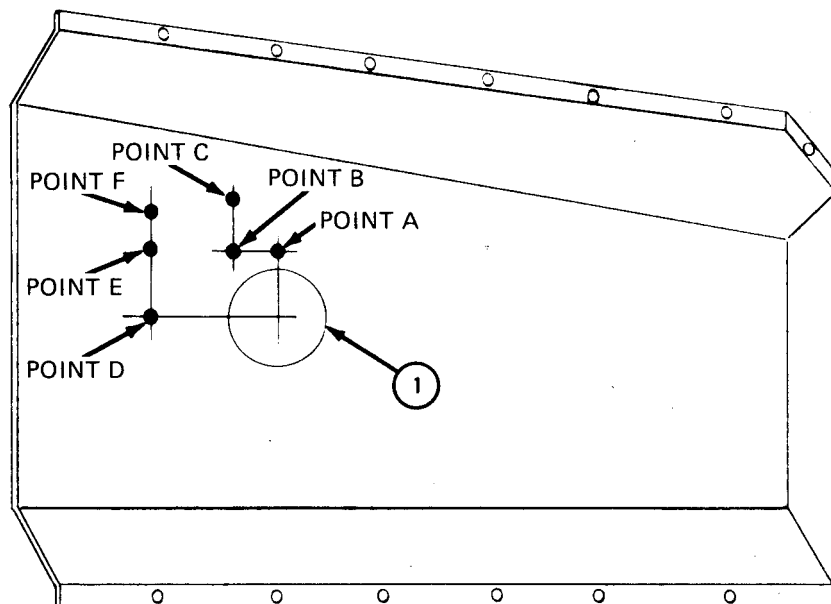

TA 103458

FRAME 4

1. Put decontamination apparatus bracket (1) on intermediate tunnel (2), alining screw holes as shown. Put in four capscrews (3) and put on nuts (4).

GO TO FRAME 5

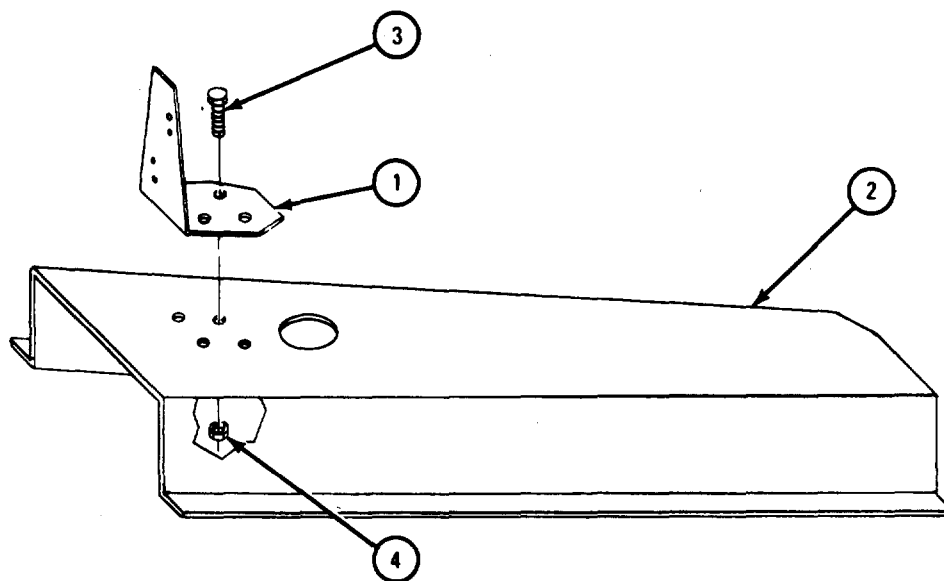

TA 104940

FRAME 5

1. Place intermediate cover (1) over front tunnel (2) and rear tunnel (3) as shown. Align mounting holes and put in 13 screws (4).

GO TO FRAME 6

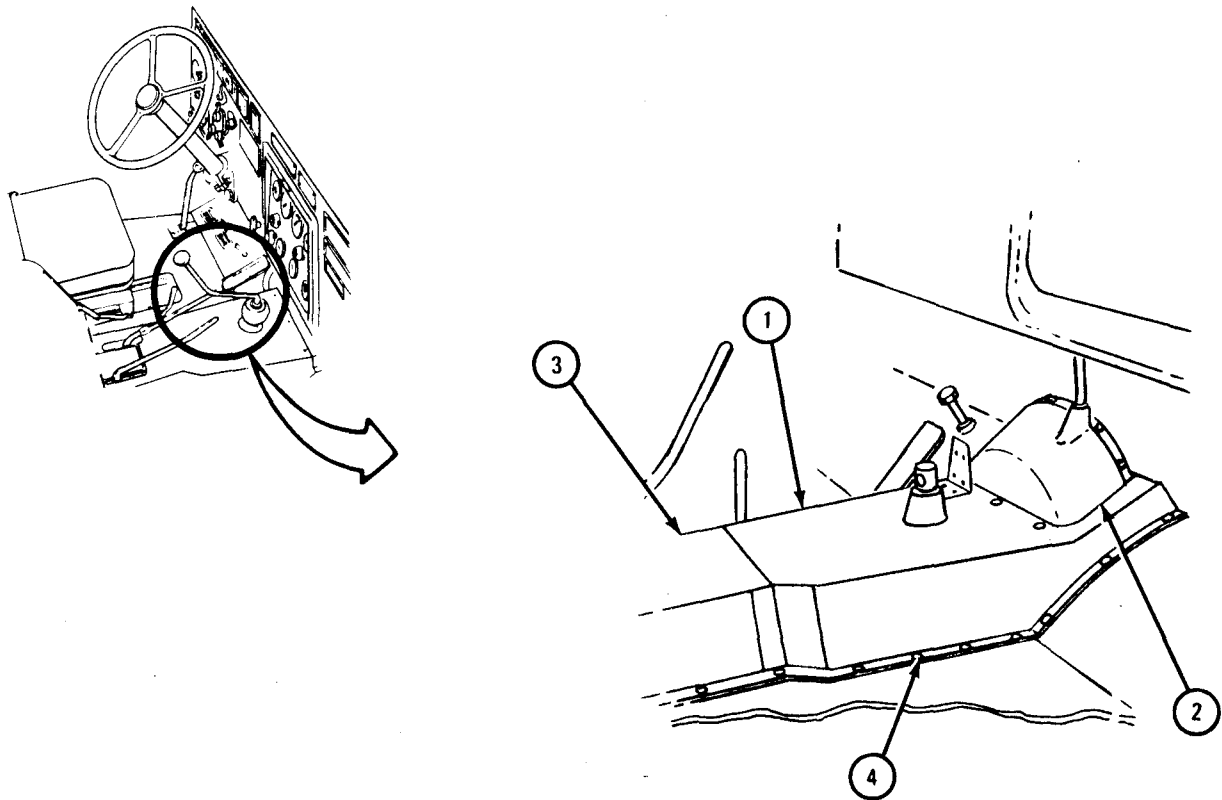

FRAME 6

1. Put gearshift lever (1) over stub shaft (2).
2. Put bolt (3) through split flange holes at bottom of gearshift lever (1).
3. Put on locknut and flat washer (4).
4. Slide rubber boot (5) down over end of gearshift lever (1).

END OF TASK

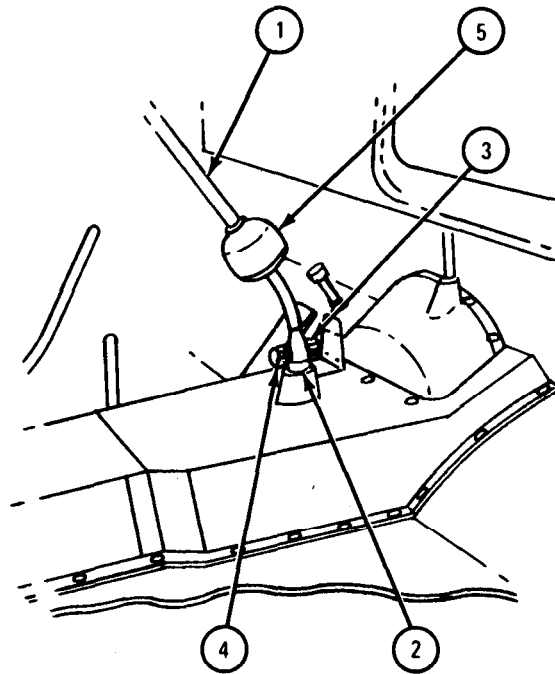

TA 104941

21-27. DECONTAMINATION APPARATUS MOUNTING KIT INSTALLATION. Install decontamination apparatus kit using instructions that come with the kit.

21-28. A-FRAME INSTALLATION. Install kit using instructions that come with the kit.

21-29. A-FRAME KIT REPAIR.

- a. Refer to TM 9-2320-209-20 for procedure to remove A-frame kit.
- b. Repair. Throw away damaged parts and get new ones.
- c. Refer to TM 9-2320-209-20 for procedure to replace A-frame kit.

21-30. ELECTRIC BRAKE KIT INSTALLATION. Install electric brake kit using instructions that come with the kit.

21-31. ENGINE SHIPPING AND STORAGE CONTAINER REPAIR.

TOOLS: Dial indicating pressure gage, pn 7541305

SUPPLIES: Soapy water
Sealing compound, MIL-S-8660

PERSONNEL: Two

EQUIPMENT CONDITION: Engine out of container.

a. Cleaning. There are no special cleaning procedures needed. Refer to cleaning procedures given in Part 1, para 1-3.

b. Disassembly.

FRAME 1

1. Take out humidity indicator (1).
2. Take out safety relief valve (2).
3. Take out pneumatic tank valve (3).
4. Take off rubber seal (4).

GO TO FRAME 2

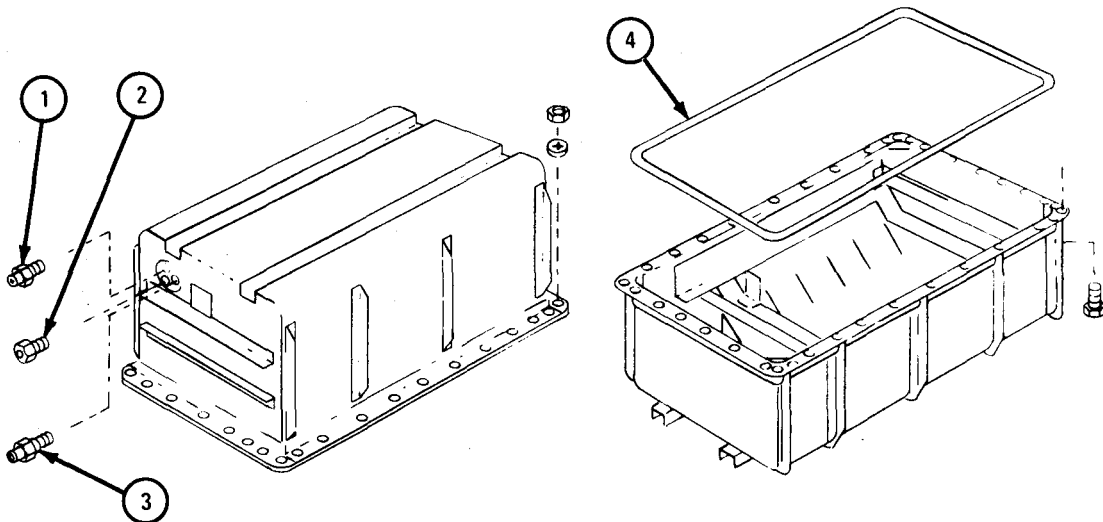

TA 103988

FRAME 2

Soldiers A and B

1. Take off four screws (1) at four mounting plates (2), two on each side.

2. Take cradle (3) out of container (4).

END OF TASK

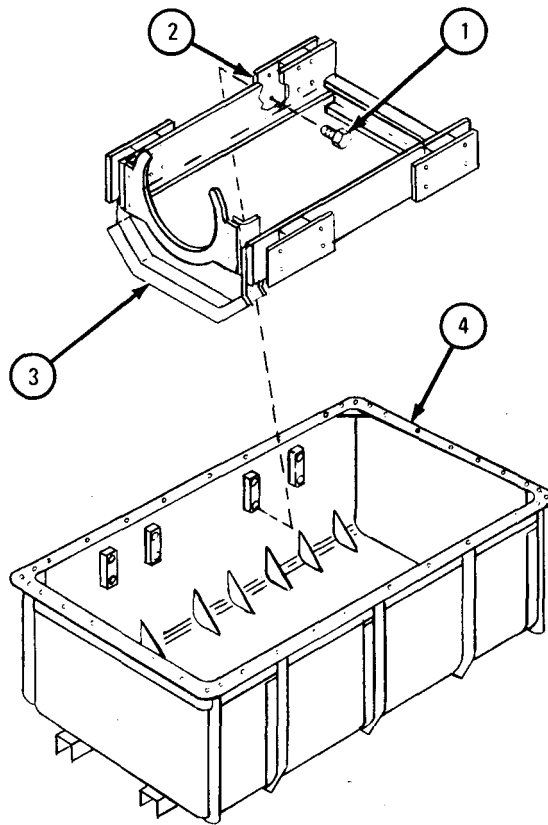

1A 103989

c. Inspection and Repair.

FRAME 1

1. Check that upper and lower parts of container (1) are not bent, dented, cracked or torn.
2. Check that cradle (2) is not bent, dented, cracked, or torn.
3. To repair bent or dented parts, refer to FM 43-2. To weld tears or cracks, refer to TM 9-237. If more repair is needed, get a new part.

GO TO FRAME 2

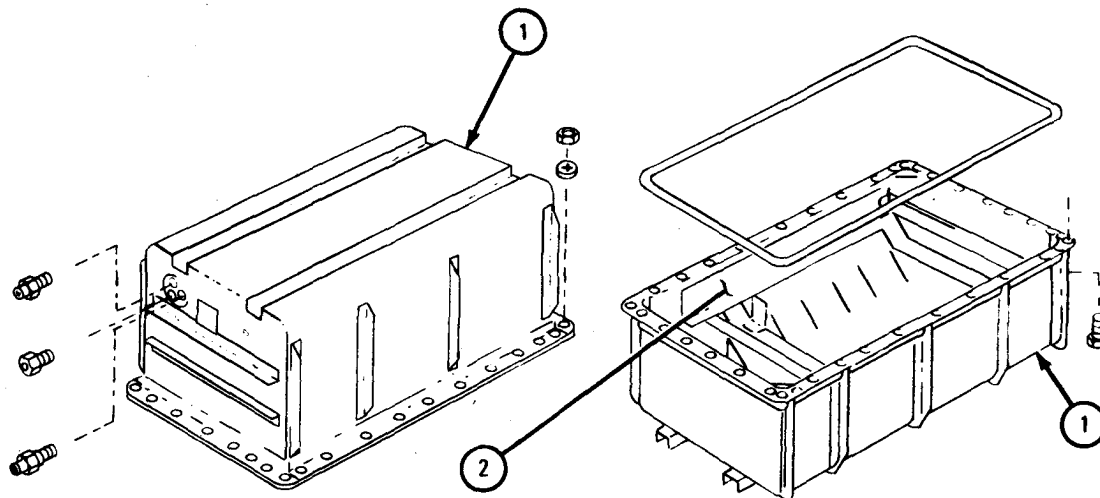

NOTE: CHECK ONLY THOSE PARTS WHICH ARE CALLED OUT IN THIS FRAME. PARTS WITHOUT CALLOUTS ARE SHOWN ONLY FOR REFERENCE PURPOSES OR ARE CHECKED IN ANOTHER FRAME.

TA 103990

FRAME 2

1. Check that rubber seal (1) is not torn or damaged. If damaged, get a new part.
2. Check that humidity indicator (2), safety relief valve (3), and pneumatic tank valve (4) are not damaged. If damaged, get a new part.
3. Check that all threaded parts are not stripped or crossthreaded. If damaged, get a new part.

END OF TASK

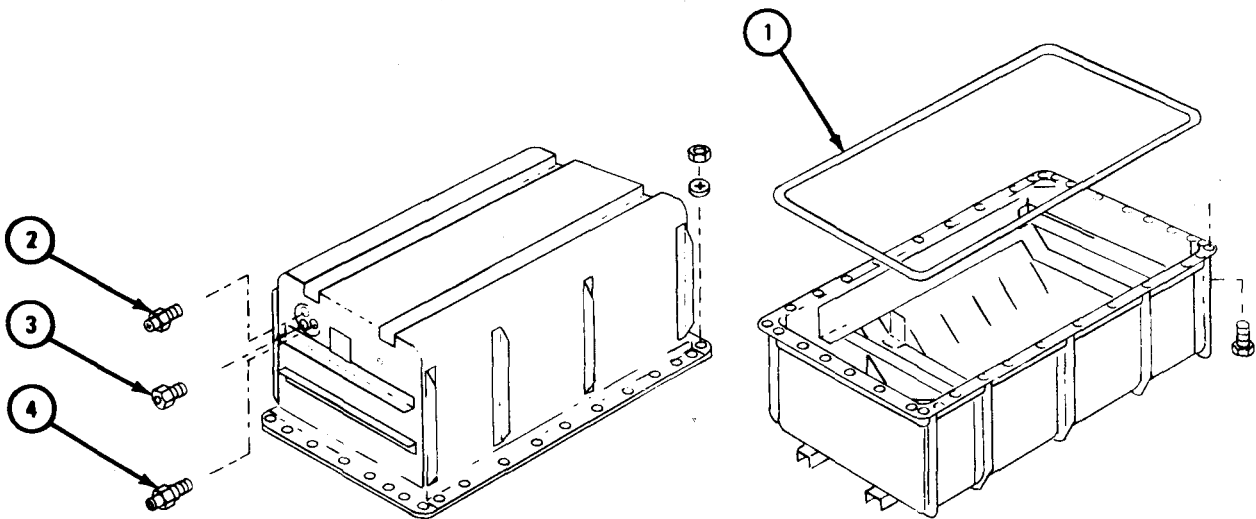

NOTE: CHECK ONLY THOSE PARTS WHICH ARE CALLED OUT IN THIS FRAME. PARTS WITHOUT CALLOUTS ARE SHOWN ONLY FOR REFERENCE PURPOSES OR ARE CHECKED IN ANOTHER FRAME.

TA 103991

d. Assembly.

FRAME 1

Soldiers A and B 1. Put cradle (1) in container (2).

Soldier A 2. Align holes of mounting plate (3) with holes in container (2).

Soldier B 3. Put in four screws (4).

Soldiers A and B 4. Do steps 2 and 3 again for three other mounting plates (3).

GO TO FRAME 2

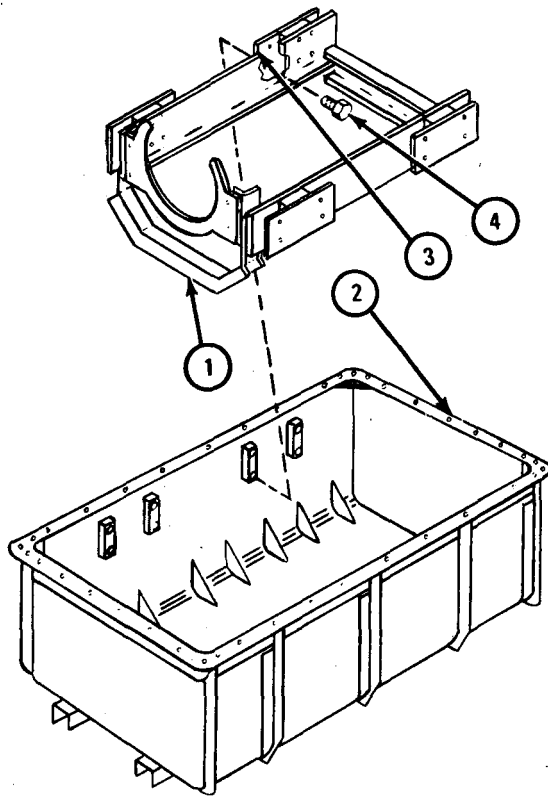

TA 103992

FRAME 2

1. Put on rubber seal (1).
2. Put in pneumatic tank valve (2).
3. Put in safety relief valve (3).
4. Put in humidity indicator (4).

END OF TASK

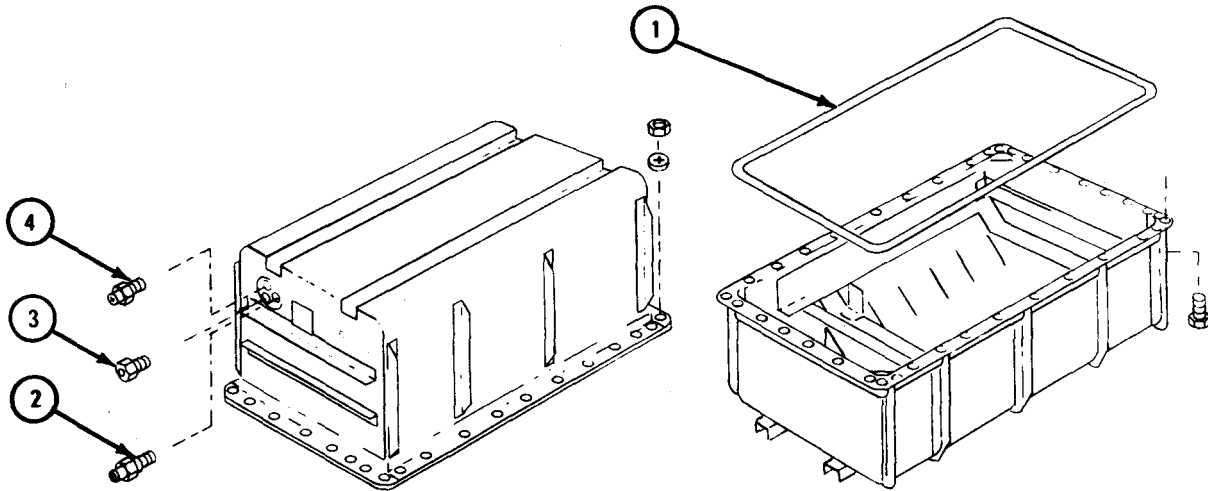

TA 103993

e. Pressure Check.

FRAME 1

- Soldier A 1. Coat rubber seal (1) with sealing compound.
- Soldiers A and B 2. Put upper part of container (2) on lower part of container.
- Soldier A 3. Put in 40 screws (3).
- Soldier B 4. Put on 40 lockwashers (4) and nuts (5).
5. Using clean, dry air, pressurize container (2), through valve (6), to 10 psi.

NOTE

Relief valve (7) should open between 7 to 10 psi.

6. If relief valve (7) does not open, replace relief valve.

GO TO FRAME 2

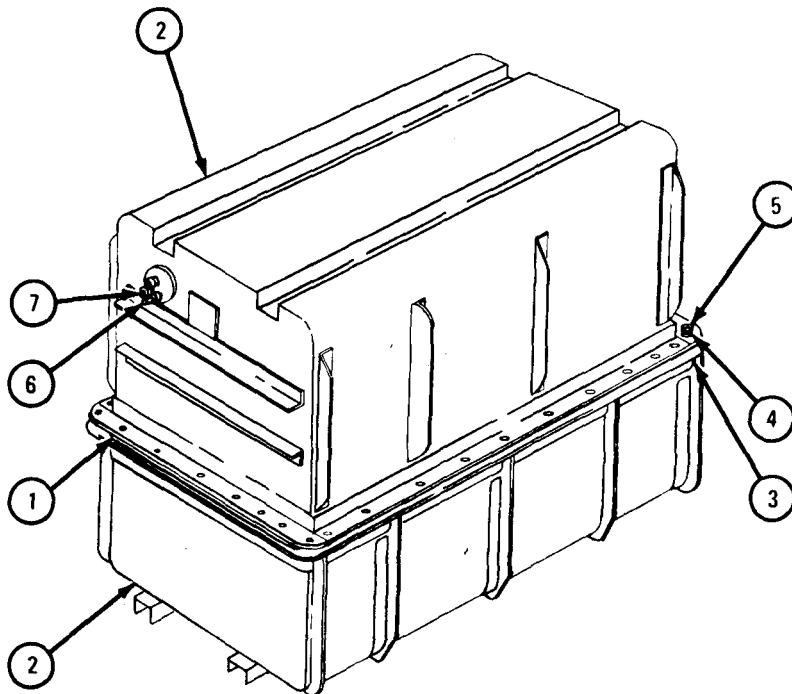

TA 103994

FRAME 2

1. Take out safety relief valve (1).
2. Put in air pressure gauge (2).
3. Using clean, dry air, pressurize container (3) to 10 psi.
4. Apply soapy water to container (3). Air bubbles or a drop in air pressure is a sign of air leak. To repair, refer to para 21-31c.
5. Take out air pressure gauge (2).
6. Put in safety relief valve (1).

END OF TASK

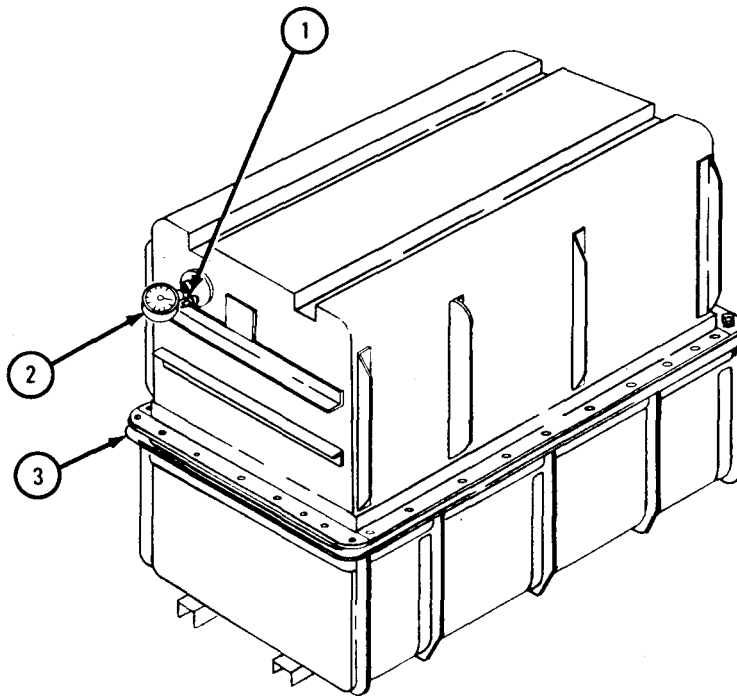

TA 103995

APPENDIX A

REFERENCES

A-1. PUBLICATION INDEXES AND GENERAL REFERENCES.

Indexes should be checked often for the latest changes or revisions of references given in this appendix and for new publications on material covered in this technical manual.

a. Military Publications Indexes.

- Index of Army Motion Pictures
and Related Audio-Visual Aids DA Pam 108-1
- Index of Administrative Publications DA Pam 310-1
- Index of Blank Forms. DA Pam 310-2
- Index of Doctrinal Training and
Organizational Publications DA Pam 310-3

Military Publications:

- Index of Technical Manuals, Technical
Bulletins, Supply Bulletins, and
Lubrications Orders DA Pam 310-4
- Index of Supply Catalogs and
Supply Manuals (excluding types
7,8, and 9) DA Pam 310-6
- Index of Modification Work Orders DA Pam 310-7
- Common Tools and Equipment
Supply Manuals DA Supply Manuals
SC-4910-95-CL-A01, A02,
A50, A63, A64, A65, A67,
A68, A72, A73, and A74.
SC-5180-90-CL-N-23,
SC-4910-95-CL-A31 and
-A32

b. General Reference.

- Authorized Abbreviations and Brevity
Codes AR 310-50
- Dictionary of United States Army Terms AR 310-25

A-2. FORMS.

The following forms are for this material (refer to DA pamphlet 310-2 for index of blank forms and to TM 38-750 for explanation of their use).

Recommended Changes to Publications	DA Form 2028
Maintenance Request - Continuation Sheet . . .	DA Form 2407-1
Equipment Log Assembly (Records)	DA Form 2408
Processing and Reprocessing Records for Shipment, Storage, and Issue of Vehicles and Spare Engines	DA Form 1397

A-3. OTHER PUBLICATIONS.

a. Vehicle Manuals

Lubrication Order	LO 9-2320-209-12/1
Operator's Manual	TM 9-2320-209-10
Organizational Maintenance Manual (Multifuel Engine)	TM 9-2320-209-20
Organizational Maintenance Repair Parts and Special Tool List.	TM 9-2320-209-20P
Direct Support and General Support Maintenance Repair Parts and Special Tool List	TM 9-2320-209-34P
Transportability Guidance ,	TM 55-2320-209-15-1

b. Engine Maintenance Manuals

Field and Depot Maintenance for Engine, Diesel (Multifuel): Turbosupercharged (LDS-427-2) and Clutch Assembly (ORD 7748995)	TM 9-2815-204-35
DS and GS Maintenance Repair Parts and Special Tools Lists (Including Depot Allowances) for Engine, Diesel (Multifuel): Turbosupercharged (LDS-427-2)	TM 9-2815-204-34P

DS, GS, and Depot Maintenance Manual:
 Engine, Diesel (Multifuel): Turbocharged
 (LD-465-1, LD-465-1C, LDS-465-1,
 LDT-465-1C, LDS-465-1A, LDS-465-2) TM 9-2815-210-34

DS and GS Maintenance Repair Parts
 and Special Tools List (Including Depot
 Maintenance Parts and Special Tools):
 Engine, Diesel (Multifuel): Turbocharged
 (LD-465-1, LD-465-1C, LDT-465-1C,
 LDS-465-1, LDS-465-1A) TM 9-2815-21-34P

c. Engine Equipment Maintenance Manuals

DS and GS Maintenance Manual (Including
 Repair Parts and Special Tools List):
 Pump, Fuel, Metering and Distributing
 Assembly NSN 2910-00-178-1185,
 NSN 2910-00-759-5410, NSN 2910-00-908-6320,
 NSN 2910-00-017-9778, and
 NSN 2910-00-116- 8241 TM 9-2910-226-34&P

GS Maintenance Manual (Including
 Repair Parts and Special Tools List):
 Turbocharger, Engine Assembly:
 Schwitzer Models 4-456, 4D-454C,
 4D-554, 4LE-354, 4LE456, 3LJ-319,
 and 3LD-305 TM 9-2990-201-40&P

d. Other Truck Equipment Maintenance Manuals

DS, GS, and Depot Maintenance Manual:
 Transmissions, Transfers, and
 Power Takeoffs TM 9-2520-246-34-1

Ordnance Maintenance: Winches, Power
 Takeoffs, Power Divider and Hydraulic
 Equipment (Gar Wood) TM 9-8617

Organizational Care, Maintenance and
 Repair of Pneumatic Tires and Inner Tubes TM 9-2610-200-20

Tactical Transport and Combat Vehicles:
 Troubleshooting for Instrument Cluster
 Gages, Switches, Circuit Breakers,
 Sending Units, and Related Wiring TB 9-2300-228-20

GS Maintenance Manual: Generator,
 Delco-Remy Model 1117495 TM 9-2920-214-34&P

GS Maintenance Manual: Generator,
 Prestolite Model GHA-4804JUT and
 Autolite Model GHA-4802UT TM 9-2920-247-34&P

GS Maintenance Manual: Generator, AC
 (Prestolite Model AMA-5102UT, Leece-
 Neville Models 3002AC and 3002AD,
 3002AE, 5504AA and 5504AB, 2184AC
 and 5300GP) TM 9-2920-225-34

DS and GS Maintenance Repair Parts
 and Special Tools Lists: (Including
 Depot Allowances) for Generator,
 AC (Prestolite Model AMA-5102UT,
 Leece-Neville Models 3002AC and
 3002AD, 3002AE, 5504AA, and
 5504AB, 2184AC, and 5300GP) TM 2920-225-34P

e. General Manuals

Administrative Storage of Equipment TM 740-90-1

The Army Maintenance Management
 System (TAMES). TM 38-750

Procedures for Destruction of Tank-
 Automotive Equipment to Prevent
 Enemy Use (US Army Tank-Automotive
 Command) TM 750-244-6

Use of Antifreeze Solutions and
 Cleaning Compounds in Engine
 Cooling Systems TB 750-651

Inspection, Care and Maintenance of
 Antifriction Bearings TM 9-214

Tactical Wheeled Vehicles, Repair of
 Frames TB 9-2300-247-40

Painting Instructions for Field Use TM 43-0139

Safety Inspection and Testing of
 Lifting Devices TB 43-0142

Operator's Manual: Welding Theory
 and Application (TO 34W4-1-5) TM 9-237

General Repair for Canvas and Webbing FM 43-3

Materials Used for Cleaning, Preserving,
 Abrading and Cementing Ordnance
 Material and Related Materials Including
 Chemicals TM 9-247

Metal Body Repair and Related Operations. . .	FM 43-2
Cooling Systems: Tactical Vehicles.	TB 750-254
Purging, Cleaning and Coating Interior Ferrous and Terne Sheet Vehicle Fuel Tanks	TB 43-0212
Color, Marking and Camouflage Painting of Military Vehicles, Construction Equip- ment, and Materials Handling Equipment . . .	TB 43-0209
Rustproofing Procedures	TB 43-0213
Security of Tactical Wheeled Vehicles	TB 9-2300-422-20

INDEX

Subject	Paragraph	Page
A		
A-frame kit installation	21-28	21-205
A-frame kit repair	21-29	21-205
Air intake and exhaust manifolds	2-21	2-205
Preliminary procedures	2-21a	2-205
Removal	2-21b	2-206
Repair	2-21c	2-231
Replacement	2-21d	2-231
Alternator and regulator repair	7-3	7-1
Axle assembly, forward-rear	11-3	11-1
Preliminary procedures	11-3a	11-1
Removal	11-3b	11-2
Replacement	11-3c	11-5
Axle assembly, rear-rear	11-4	11-8
Preliminary procedures	11-4a	11-8
Removal	11-4b	11-8
Replacement	11-4c	11-11
Axle drive flange, front, repair	10-6	10-38
Assembly	10-6e	10-40
Cleaning	10-6b	10-38
Disassembly	10-6c	10-38
Inspection and repair	10-6d	10-39
Preliminary procedure	10-6a	10-38
Axle housing, forward-rear and rear-rear, repair	11-5	11-14
Assembly	11-5e	11-16
Cleaning	11-5c	11-15
Disassembly	11-5b	11-14
Inspection and repair	11-5d	11-15
Preliminary procedures	11-5a	11-14
Axle, front, removal	10-3	10-1
Preliminary procedure	10-3a	10-1
Removal	10-3b	10-2
Replacement	10-3c	10-4
Axle, front, repair	10-4	10-8
Assembly	10-4e	10-19
Cleaning	10-4c	10-16
Disassembly	10-4b	10-9
Inspection and repair	10-4d	10-17
Preliminary procedures	10-4a	10-8
Axle, front, steering arm, repair	10-9	10-107
Axle, rear, hub, repair	11-6	11-17
Assembly	11-6f	11-21
Cleaning	11-6c	11-19
Disassembly	11-6b	11-17
Inspection	11-6d	11-20
Preliminary procedures	11-6a	11-17
Repair	11-6e	11-21

INDEX - CONT

Subject	Paragraph	Page
A - Cont		
Axle, rear, spring brackets and crossrod	11-8	11-41
Cleaning	11-8c	11-43
Inspection and repair	11-8d	11-43
Preliminary procedures	11-8a	11-41
Removal	11-8b	11-42
Replacement	11-8e	11-44
Axle shaft and universal joint, front, repair	10-5	10-27
Assembly	10-5e	10-35
Cleaning	10-5c	10-31
Disassembly	10-5b	10-27
Inspection and repair	10-5d	10-31
Preliminary procedure	10-5a	10-27
B		
Battery inspection, removal, service, and replacement	7-4	7-1
Bearing, clutch release, and yoke, throwout shaft	3-5	3-5
Bearings, connecting rod	2-12	2-132
Bearings, maintenance	10-8	10-99
Cleaning of bearings	10-8e	10-103
Inspection of bearings	10-8f	10-104
Removal of bearing from housing by pressing	10-8c	10-101
Removal of bearing from housing by pulling	10-8d	10-102
Removal of bearing from shaft by pressing	10-8a	10-99
Removal of bearing from shaft by pulling	10-8b	10-100
Replacement of bearing into housing	10-8h	10-106
Replacement of bearing into shaft	10-8g	10-105
Body Cover repair	20-3	20-1
Body curtain repair	20-4	20-1
Brake, air, hand control valve, trailer, repair	12-7	12-58
Assembly	12-7e	12-62
Cleaning	12-7c	12-62
Disassembly	12-7b	12-59
Inspection and repair	12-7d	12-62
Preliminary procedure	12-7a	12-58
Brake, air, hydraulic cylinder, repair	12-5	12-7
Air cylinder and air tube cleaning, inspection and repair	12-5d	12-23
Air cylinder piston assembly repair	12-5c	12-16
Assembly of air hydraulic cylinder assembly	12-5j	12-36
Disassembly into subassemblies	12-5b	12-8
Preliminary procedures	12-5a	12-7
Pushrod bushing assembly repair	12-5f	12-26
Slave cylinder body repair	12-5e	12-24

INDEX - CONT

Subject	Paragraph	Page
B - Cont		
Slave cylinder compensator assembly repair	12-5g	12-27
Slave cylinder compensator piston assembly repair	12-5h	12-32
Slave cylinder control valve piston assembly repair	12-5i	12-34
Brake, service and handbrake, repair	12-3	12-1
Assembly	12-3e	12-4
Cleaning	12-3c	12-3
Disassembly	12-3b	12-2
Inspection and repair	12-3d	12-3
Preliminary procedure	12-3a	12-1
Brake, trailer, hand control valve, repair	12-7	12-58
Brake drum, service, front and rear, repair	12-4	12-5
Cleaning	12-4b	12-5
Inspection and repair	12-4c	12-6
Preliminary procedure	12-4a	12-5
Brake, electric, kit	21-30	21-205
Brake hose, front	12-6	12-46
Preliminary procedures	12-6a	12-46
Removal	12-6b	12-47
Replacement	12-6c	12-51
Brake system items covered	12-1	12-1
Brake system items not covered	12-2	12-1
Bumper, front, and reinforcing gussets (all trucks with front winch)	19-4	19-7
Cleaning	19-4c	19-9
Inspection and repair	19-4d	19-9
Preliminary procedure	19-4a	19-7
Removal	19-4b	19-7
Replacement	19-4e	19-10
Bumper, front, and reinforcing gussets (all trucks without front winch)	19-3	19-1
Assembly	19-3f	19-5
Cleaning	19-3d	19-4
Disassembly	19-3c	19-3
Inspection and repair	19-3e	19-4
Preliminary procedures	19-3a	19-1
Removal	19-3b	19-2
Replacement	19-3g	19-6
Bumperettes, rear (all trucks except M275A1, M275A2, and M342A2)	19-7	19-21
Preliminary procedure	19-7a	19-21
Removal	19-7b	19-21
Replacement	19-7c	19-22

INDEX - CONT

Subject	Paragraph	Page
C		
Cab door repair	17-6	17-52
Assembly	17-6f	17-67
Cleaning	17-6c	17-65
Disassembly	17-6b	17-53
Inspection	17-6d	17-65
Removal	17-6a	17-52
Repair	17-6e	17-67
Replacement	17-6g	17-78
Cab Protector	17-61	17-742
Cleaning	17-61c	17-744
Inspection and repair	17-61d	17-744
Preliminary procedure	17-61a	17-742
Removal	17-61b	17-742
Replacement	17-61e	17-745
Cab repair.	17-5	17-14
Assembly	17-5f	17-33
Cleaning	17-5d	17-30
Disassembly	17-5c	17-18
Inspection and repair	17-5e	17-30
Preliminary procedures	17-5a	17-14
Removal	17-5b	17-15
Replacement	17-5g	17-47
Camshaft and crankshaft gears	2-16	2-157
Preliminary procedures	2-16a	2-157
Removal	2-16b	2-158
Replacement	2-16c	2-163
Camshaft assembly	2-15	2-148
Preliminary procedures	2-15a	2-148
Removal	2-15b	2-149
Replacement	2-15c	2-153
Cargo body	17-16	17-147
Cleaning	17-16c	17-151
Inspection and repair	17-16d	17-151
Preliminary procedure	17-16a	17-147
Removal	17-16b	17-148
Replacement	17-16e	17-152
Cargo body (truck M764)	17-60	17-735
Cargo body tailgate repair (truck M35A1)	17-17	17-156
Assembly	17-17e	17-158
Cleaning	17-17c	17-157
Disassembly	17-17b	17-156
Inspection and repair	17-17d	17-157
Preliminary procedure	17-17a	17-156

INDEX - CONT

Subject	Paragraph	Page
C - Cont		
Cargo body tailgate repair (truck M35A2C)	17-18	17-159
Assembly	17-18e	17-163
Cleaning	17-18c	17-162
Disassembly	17-18b	17-160
Inspection and repair	17-18d	17-162
Preliminary procedure	17-18a	17-159
Circuit breaker box	17-36	17-387
Cleaning	17-36c	17-390
Inspection and repair	17-36d	17-390
Preliminary procedure	17-36a	17-387
Removal	17-36b	17-388
Replacement	17-36e	17-391
Cleaning, general procedures	1-3	1-1
Clutch assembly	3-3	3-1
Preliminary procedure	3-3a	3-1
Removal	3-3b	3-2
Repair	3-4	3-5
Replacement	3-3c	3-3
Clutch release bearing and throwout shaft yoke	3-5	3-5
Preliminary procedure	3-5a	3-5
Removal	3-5b	3-5
Replacement	3-5c	3-7
Communication door.....	17-34	17-376
Assembly	17-34e	17-381
Cleaning	17-34c	17-379
Disassembly	17-34b	17-378
Inspection and repair	17-34d	17-380
Removal	17-34a	17-377
Replacement	17-34f	17-382
Companion seat (early model) repair	17-14	17-134
Assembly	17-14e	17-137
Cleaning	17-14c	17-136
Disassembly	17-14b	17-134
Inspection and repair	17-14d	17-136
Preliminary procedures	17-14a	17-134
Companion seat, (late model) repair.	17-15	17-139
Assembly	17-15e	17-144
Cleaning	17-15c	17-143
Disassembly	17-15b	17-140
Inspection and repair	17-15d	17-143
Preliminary procedures	17-15a	17-139
Connecting rod and piston assembly	2-13	2-132
Connecting rod bearings	2-12	2-132

INDEX - CONT

Subject	Paragraph	Page
C - Cont		
Container, engine, shipping and storage, repair	21-31	21-206
Assembly	21-31d	21-210
Cleaning	21-31a	21-206
Disassembly	21-31b	21-206
Inspection and repair	21-31c	21-208
Pressure check	21-31e	21-212
Control valve (truck M342A2)	18-10	18-214
Preliminary procedures	18-10a	18-214
Removal	18-10b	18-214
Replacement	18-10c	18-216
Converter	17-37	17-393
Removal	17-37a	17-393
Replacement	17-37b	17-395
Crankshaft, front, oil seal	2-10	2-120
Preliminary procedures	2-10a	2-120
Removal	2-10b	2-120
Replacement	2-10c	2-121
Crankshaft, main bearings	2-9	2-120
Crankshaft, vibration damper	2-8	2-106
Preliminary procedures	2-8a	2-106
Removal	2-8b	2-106
Replacement	2-8c	2-113
Crossrod and spring brackets	11-8	11-41
Cylinder head (engines LD 465-1, LD 465-1C, and LDT 465-1C)	2-6	2-42
Cleaning, inspection, and repair	2-6c	2-69
Preliminary procedure	2-6a	2-42
Removal	2-6b	2-43
Replacement	2-6d	2-69
Cylinder sleeve	2-7	2-106

D

Decontamination apparatus mounting bracket installation	21-26	21-199
Decontamination apparatus mounting kit installation	21-27	21-205
Delivery pump repair (trucks M49A1C, M49A2C, M50A1, M50A2, and M50A3)	17-26	17-230
Assembly	17-26f	17-242
Cleaning	17-26c	17-234
Disassembly	17-26b	17-230
Inspection	17-26d	17-235
Preliminary procedure	17-26a	17-230
Repair	17-26e	17-240
Test and adjustment	17-26g	17-250

INDEX - CONT

Subject	Paragraph	Page
D - Cont		
Differential carrier, repair	10-7	10-41
Assembly and adjustment	10-7f	10-69
Cleaning	10-7d	10-62
Disassembly	10-7c	10-44
Inspection and repair	10-7e	10-63
Preliminary procedures	10-7a	10-41
Removal	10-7b	10-43
Replacement	10-7g	10-97
Dome light (115 volt) repair	17-35	17-383
Assembly	17-35e	17-386
Cleaning	17-35c	17-384
Disassembly	17-35b	17-383
Inspection and repair	17-35d	17-385
Preliminary procedure	17-35a	17-383
Door hinges, rear (trucks M109A2 and M109A3)	17-38	17-397
Double sprag transmission, transfer, repair	9-5	9-8
Driver's seat assembly, floating, repair	17-12	17-122
Assembly	17-12e	17-127
Disassembly	17-12b	17-122
Inspection	17-12c	17-126
Preliminary procedure	17-12a	17-122
Repair	17-12d	17-127
Driver's seat (early model) repair	17-13	17-131
Assembly	17-13e	17-133
Cleaning	17-13c	17-132
Disassembly	17-13b	17-131
Inspection and repair	17-13d	17-132
Preliminary procedure	17-13a	17-131
Dump body tailgate assembly	17-66	17-773
Assembly	17-66f	17-776
Cleaning	17-66d	17-775
Disassembly	17-66c	17-774
Inspection and repair	17-66e	17-775
Preliminary procedure	17-66a	17-773
Removal	17-66b	17-773
Replacement	17-66g	17-777
Dump truck body	17-68	17-799
Assembly	17-68f	17-817
Cleaning	17-68d	17-813
Disassembly	17-68c	17-803
Inspection and repair	17-68e	17-814
Preliminary procedure	17-68a	17-799
Removal	17-68b	17-800
Replacement	17-68g	17-828
Tailgate linkage adjustment	17-68h	17-831

INDEX - CONT

Subject	Paragraph	Page
D - Cont		
Dump truck subframe	17-65	17-763
Preliminary procedures	17-65a	17-763
Removal	17-65b	17-763
Replacement	17-65c	17-768
E		
Earth boring machine assembly	17-45	17-479
Preliminary procedures	17-45a	17-479
Removal	17-45b	17-479
Replacement	17-45c	17-482
Earth boring machine, boring case and gears	17-46	17-485
Assembly	17-46g	17-504
Cleaning	17-46d	17-501
Disassembly	17-46c	17-493
Inspection	17-46e	17-501
Preliminary procedure	17-46a	17-485
Removal	17-46b	17-486
Repair	17-46f	17-504
Replacement	17-46h	17-514
Earth boring machine, cargo body	17-60	17-735
Cleaning	17-60c	17-738
Inspection and repair	17-60d	17-738
Preliminary procedures	17-60a	17-735
Removal	17-60b	17-736
Replacement	17-60e	17-739
Earth boring machine, derrick sheave assembly	17-57	17-715
Assembly	17-57e	17-721
Cleaning	17-57c	17-718
Disassembly	17-57b	17-716
Inspection and repair	17-57d	17-718
Preliminary procedure	17-57a	17-715
Earth boring machine, feed and drive clutch and brake assemblies and clutch shaft pinions	17-52	17-642
Assembly	17-52e	17-659
Cleaning	17-52c	17-657
Disassembly	17-52b	17-643
Inspection and repair	17-52d	17-657
Preliminary procedures	17-52a	17-642
Earth boring machine, integral derrick and snatch sheave assembly	17-56	17-708
Cleaning	17-56c	17-712
Inspection and repair	17-56d	17-712
Preliminary procedure	17-56a	17-708
Removal	17-56b	17-709
Replacement	17-56e	17-713

INDEX - CONT

Subject	Paragraph	Page
E - Cont		
Earth boring machine, intermediate case and gear assembly	17-47	17-530
Adjustment	17-47i	17-550
Assembly	17-47g	17-541
Cleaning	17-47d	17-540
Disassembly	17-47c	17-533
Inspection	17-47e	17-540
Preliminary procedure	17-47a	17-530
Removal	17-47b	17-531
Repair	17-47f	17-541
Replacement	17-47h	17-547
Earth boring machine, leveling worm gear, horizontal and housing assembly	17-49	17-586
Assembly	17-49g	17-597
Cleaning	17-49d	17-594
Disassembly	17-49c	17-590
Inspection	17-49e	17-594
Preliminary procedure	17-49a	17-586
Removal	17-49b	17-587
Repair	17-49f	17-597
Replacement	17-49h	17-604
Earth boring machine, leveling worm gear, vertical, and housing assembly	17-50	17-609
Adjustment	17-50g	17-627
Assembly	17-50f	17-622
Cleaning	17-50d	17-617
Disassembly	17-50c	17-613
Inspection and repair	17-50e	17-617
Preliminary procedure	17-50a	17-609
Removal	17-50b	17-610
Replacement	17-50h	17-628
Earth boring machine, main drive idler gear assembly	17-48	17-568
Assembly	17-48f	17-579
Cleaning	17-48d	17-576
Disassembly	17-48c	17-570
Inspection and repair	17-48e	17-576
Preliminary procedures	17-48a	17-568
Removal	17-48b	17-569
Replacement	17-48g	17-585
Earth boring machine, operation lever assembly	17-51	17-631
Assembly	17-51e	17-637
Cleaning	17-51c	17-636
Disassembly	17-51b	17-634
Inspection and repair	17-51d	17-636
Removal	17-51a	17-631
Replacement	17-51f	17-639

INDEX - CONT

Subject	Paragraph	Page
E - Cont		
Earth boring machine, operator's seat	17-44	17-472
Assembly	17-44e	17-476
Cleaning	17-44c	17-475
Disassembly	17-44b	17-473
Inspection and repair	17-44d	17-475
Removal	17-44a	17-472
Replacement	17-44f	17-478
Earth boring machine, outrigger legs	17-54	17-688
Assembly	17-54f	17-693
Cleaning	17-54d	17-692
Disassembly	17-54c	17-690
Inspection and repair	17-54e	17-692
Preliminary procedure	17-54a	17-688
Removal	17-54b	17-688
Replacement	17-54g	17-695
Earth boring machine, outrigger leg hydraulic cylinder	17-55	17-697
Assembly	17-55f	17-703
Cleaning	17-55d	17-702
Disassembly	17-55c	17-699
Inspection and repair	17-55e	17-702
Preliminary procedure	17-55a	17-697
Removal	17-55b	17-698
Replacement	17-55g	17-706
Test	17-55h	17-707
Earth boring machine, pioneer tool bracket	17-59	17-731
Assembly	17-59f	17-733
Cleaning	17-59d	17-733
Disassembly	17-59c	17-732
Inspection and repair	17-59e	17-733
Preliminary procedure	17-59a	17-731
Removal	17-59b	17-731
Replacement	17-59g	17-734
Earth boring machine, power leveler	17-53	17-672
Assembly	17-53f	17-681
Cleaning	17-53d	17-679
Disassembly	17-53c	17-675
Inspection and repair	17-53e	17-679
Preliminary procedures	17-53a	17-672
Removal	17-53b	17-672
Replacement	17-53g	17-685
Earth boring machine, snatch sheave assembly	17-58	17-724
Assembly	17-58e	17-729
Cleaning	17-58c	17-727
Disassembly	17-58b	17-725
Inspection and repair	17-58d	17-728
Preliminary procedure	17-58a	17-724

INDEX - CONT

Subject	Paragraph	Page
E - Cont		
Electric brake kit installation	21-30	21-205
Engine assembly, removal and replacement	2-3	2-1
Engine assembly, repair (LD 465-1, LD 465-1C, and LDT 465-1C)	2-4	2-42
Engine assembly, repair (LDS 427-2)	2-5	2-42
Engine heater kit	21-4	21-1
End gate control linkage	17-67	17-778
Cleaning and inspection	17-67c	17-785
Preliminary procedure	17-67a	17-778
Removal	17-67b	17-778
Repair	17-67d	17-789
Replacement	17-67e	17-789
Exhaust bypass fording valve (trucks M50A1 and M50A2)	5-3	5-1
Assembly	5-3f	5-6
Cleaning	5-3d	5-5
Disassembly	5-3c	5-3
Inspection and repair	5-3e	5-5
Preliminary procedure	5-3a	5-1
Removal	5-3b	5-2
Replacement	5-3g	5-8
F		
Fender, front	17-7	17-79
Assembly	17-7f	17-88
Cleaning	17-7d	17-88
Disassembly	17-7c	17-87
Inspection and repair	17-7e	17-88
Preliminary procedures	17-7a	17-79
Removal	17-7b	17-80
Replacement	17-7g	17-89
Fender, rear (trucks M275A1 and M275A2)	17-8	17-97
Cleaning	17-8b	17-99
Inspection and repair	17-8c	17-99
Removal	17-8a	17-97
Replacement	17-8d	17-100
Fifth wheel assembly	15-6	15-57
Assembly	15-6f	15-66
Cleaning	15-6c	15-65
Disassembly	15-6b	15-57
Inspection	15-6d	15-65
Preliminary procedure	15-6a	15-57
Repair	15-6e	15-66

INDEX - CONT

Subject	Paragraph	Page
F - Cont		
Filter separator (truck M49A2C)	17-23	17-197
Assembly	17-23f	17-202
Cleaning	17-23d	17-202
Disassembly	17-23c	17-202
Inspection and repair	17-23e	17-202
Preliminary procedure	17-23a	17-197
Removal	17-23b	17-197
Replacement	17-23g	17-202
Floodlight harness	7-10	7-33
Floor boards	17-62	17-747
Cleaning	17-62c	17-749
Inspection and repair	17-62d	17-749
Preliminary procedures	17-62a	17-747
Removal	17-62b	17-748
Replacement	17-62e	17-750
Flywheel	2-11	2-123
Cleaning	2-11c	2-126
Inspection and repair	2-11d	2-126
Preliminary procedures	2-11a	2-123
Removal	2-11b	2-123
Replacement	2-11e	2-126
Test	2-11f	2-128
Folding step	17-42	17-451
Cleaning	17-42c	17-455
Inspection and repair	17-42d	17-455
Preliminary procedure	17-42a	17-451
Removal	17-42b	17-452
Replacement	17-42e	17-456
Fording, deep water, air pressurizing system regulator valve	21-23	21-185
Preliminary procedure	21-23a	21-185
Removal	21-23b	21-185
Replacement	21-23c	21-187
Fording, deep water, air pressurizing system hose (trucks M35A1 and M35A2)	21-24	21-190
Removal	21-24a	21-190
Replacement	21-24b	21-193
Fording, deep water, air pressurizing system shutoff valve	21-22	21-176
Removal	21-22a	21-176
Replacement	21-22b	21-180
Fording, deep water, exhaust extension gasket	21-25	21-196
Removal	21-25a	21-196
Replacement	21-25b	21-197

INDEX - CONT

Subject	Paragraph	Page
F - Cont		
Fording kit, deep water, installation	21-19	21-139
Fording kit, deep water, operating tests	21-20	21-139
Exhaust operating test	21-20d	21-143
Intake operating test	21-20b	21-139
Preliminary procedure	21-20a	21-139
Vent operating test	21-20c	21-142
Fording kit, deep water, repair	21-21	21-146
Cleaning	21-21c	21-159
Inspection and repair	21-21d	21-159
Preliminary procedures	21-21a	21-146
Removal	21-21b	21-147
Replacement	21-21e	21-164
Frame alignment check	15-3	15-1
Preliminary procedures	15-3a	15-1
Alignment check	15-3b	15-2
Frame components, removal and replacement	15-4	15-7
Air tank support brackets	15-4h	15-23
Bumperettes	15-4n	15-35
Fender supports, front, (all trucks except M342A2)	15-4j	15-27
Fender supports, front, (truck M342A2)	15-4s	15-45
Frame bracket, rear	15-4m	15-33
Fuel filter bracket (truck M342A2)	15-4t	15-47
Fuel tank, support (trucks M275A1 and M275A2)	15-4b	15-9
Rear member (trucks M275A1 and M275A2)	15-4g	15-19
Rear member bracket (trucks M275A1 and M275A2)	15-4e	15-15
Running board and fuel tank supports	15-4i	15-25
Running board supports, left (truck M342A2)	15-4q	15-41
Running board supports, right (truck M342A2)	15-4p	15-39
Running board support, all trucks (except M342A2)	15-4l	15-31
Running board support (truck M342A2)	15-4r	15-43
Side member support (trucks M275A1 and M275A2)	15-4a	15-7
Skid plate bracket	15-4d	15-13
Spare tire carrier	15-4k	15-29
Taillight and stoplight assembly bracket	15-4c	15-11
Tool box supports (truck M342A2)	15-4o	15-37
Trailer air brake coupling bracket (trucks M275A1 and M275A2)	15-4f	15-17
Front axle and universal joint, repair	10-5	10-27
Front axle drive shaft, repair	10-6	10-38

INDEX - CONT

Subject	Paragraph	Page
F - Cont		
Front axle steering arm repair	10-9	10-107
Assembly	10-9f	10-111
Cleaning	10-9d	10-110
Disassembly	10-9c	10-109
Inspection and repair	10-9e	10-110
Preliminary procedure	10-9a	10-107
Removal	10-9b	10-107
Replacement	10-9g	10-112
Front crossmember replacement kit installation	15-5	15-49
Preliminary procedures	15-5a	15-49
Removal	15-5b	15-49
Replacement	15-5c	15-53
Fuel burning personnel heater, installation	21-7	21-64
Fuel burning personnel heater, repair	21-9	21-64
Fuel burning personnel heater, test	21-8	21-64
Fuel injector nozzle and holder	4-3	4-1
Preliminary procedure	4-3a	4-1
Removal	4-3b	4-2
Replacement	4-3c	4-4
Fuel tank body (truck M49A1C)	17-27	17-257
Cleaning	17-27c	17-276
Inspection and repair	17-27d	17-276
Preliminary procedures	17-27a	17-257
Removal	17-27b	17-258
Replacement	17-27e	17-276
Fuel tank body (truck M49A2C)	17-28	17-290
Cleaning	17-28c	17-312
Inspection and repair	17-28d	17-312
Preliminary procedures	17-28a	17-290
Removal	17-28b	17-291
Replacement	17-28e	17-312
Fuel tank discharge valve control	17-24	17-206
Assembly	17-24e	17-213
Cleaning	17-24c	17-211
Disassembly	17-24b	17-206
Inspection and repair	17-24d	17-211
Preliminary procedures	17-24a	17-206
Test	17-24f	17-218
Fuel tank repair (all trucks except M275A1, M275A2, and M342A2)	4-7	4-6
Assembly	4-7e	4-10
Cleaning	4-7c	4-8
Disassembly	4-7b	4-7
Inspection and repair	4-7d	4-9
Preliminary procedures	4-7a	4-6

INDEX - CONT

Subject	Paragraph	Page
F - Cont		
Fuel tank discharge valve control	17-24	17-206
Assembly	17-24e	17-213
Cleaning	17-24c	17-211
Disassembly	17-24b	17-206
Inspection and repair	17-24d	17-211
Preliminary procedures	17-24a	17-206
Test	17-24f	17-218
Fuel tank repair (trucks M275A1, M275A2, and M342A2)	4-8	4-11
Assembly	4-8d	4-13
Cleaning, inspection, and repair	4-8c	4-12
Disassembly	4-8b	4-11
Preliminary procedures	4-8a	4-11
Fuel tank, vehicle support (all trucks except M275A1 and M275A2)	19-6	19-17
Preliminary procedure	19-6a	19-17
Removal	19-6b	19-17
Replacement	19-6c	19-19
G		
Gears, crankshaft and camshaft removal and replacement	2-16	2-157
General maintenance	1-2	1-1
Gravity delivery line gate valve	17-29	17-327
Assembly	17-29f	17-334
Cleaning	17-29d	17-333
Disassembly	17-29c	17-330
Inspection and repair	17-29e	17-333
Preliminary procedure	17-29a	17-327
Removal	17-29b	17-328
Replacement	17-29g	17-337
H		
Handbrake and service brakeshoe repair	12-3	12-1
Hard top closure kit installation	21-15	21-119
Installation	21-15a	21-119
Preliminary procedures	21-15b	21-119
Hard top closure kit, repair	21-16	21-120
Assembly	21-16e	21-125
Cleaning	21-16c	21-124
Disassembly	21-16b	21-122
Inspection and repair	21-16d	21-124
Removal	21-16a	21-120
Replacement	21-16f	21-127

INDEX - CONT

Subject	Paragraph	Page
H - Cont		
Heater control box	21-17	21-130
Assembly	21-17d	21-134
Disassembly	21-17b	21-131
Functional test	21-17f	21-139
Inspection and repair	21-17c	21-134
Removal	21-17a	21-130
Replacement	21-17e	21-138
Heater, fuel burning personnel, installation	21-7	21-64
Heater, fuel burning personnel, repair	21-9	21-64
Assembly	21-9g	21-91
Disassembly	21-9c	21-66
Disassembly, inspection, repair, assembly, and adjustment of flame detector switch	21-9d	21-76
Disassembly, inspection, repair, assembly, and test of fuel control valve	21-9e	21-79
General cleaning, inspection, and repair	21-9f	21-91
Preliminary procedures	21-9a	21-64
Removal	21-9b	21-65
Replacement	21-9h	21-101
Heater, fuel burning personnel, test	21-8	21-64
Heater kit, engine, installation	21-4	21-1
Heater kit, hot water, personnel, installation	21-3	21-1
Heater, personnel, primary, van body, repair	21-13	21-119
Heater, personnel, van body, installation	21-10	21-102
Heater, personnel, van body, operating test (trucks M109A2, M109A3, M185A2, and M185A3)	21-12	21-102
Primary van body personnel heater	21-12a	21-103
Secondary van body personnel heater	21-12b	21-111
Heater, personnel, van body, test	21-11	21-102
Heater, powerplant	21-6	21-16
Assembly	21-6e	21-51
Cleaning and inspection of subassemblies	21-6d	21-29
Disassembly into subassemblies	21-6c	21-18
Preliminary procedures	21-6a	21-16
Removal	21-6d	21-17
Replacement	21-6f	21-63
Heater, powerplant, test	21-5	21-2
Preliminary procedure	21-5a	21-2
Testing	21-5b	21-2
Heater, secondary, van body, repair	21-14	21-119
Hoist cylinder, hydraulic, (truck M341A2)	18-8	18-190
Assembly	18-8g	18-198
Cleaning	18-8d	18-197
Disassembly	18-8c	18-193
Inspection	18-8e	18-197

INDEX - CONT

Subject	Paragraph	Page
H - Cont		
Preliminary procedures	18-8a	18-190
Removal	18-8b	18-191
Repair	18-8f	18-198
Replacement	18-8h	18-203
Hoist, hydraulic (truck M342A2)	18-7	18-169
Assembly	18-7f	18-180
Cleaning	18-7d	18-176
Disassembly	18-7c	18-172
Inspection and repair	18-7e	18-176
Preliminary procedure	18-7a	18-169
Removal	18-7b	18-169
Replacement	18-7g	18-186
Hoist pump assembly, hydraulic (truck M342A2)	18-9	18-205
Assembly	18-9g	18-210
Cleaning	18-9d	18-209
Disassembly	18-9c	18-206
Inspection	18-9e	18-209
Preliminary procedures	18-9a	18-205
Removal	18-9b	18-205
Repair	18-9f	18-210
Replacement	18-9h	19-213
Hood assembly repair	17-4	17-7
Assembly	17-4g	17-11
Cleaning	17-4d	17-10
Disassembly	17-4c	17-8
Inspection	17-4e	17-10
Preliminary procedure	17-4a	17-7
Removal	17-4b	17-7
Repair	17-4f	17-10
Replacement	17-4h	17-13
Hood side panels	17-3	17-1
Assembly	17-3f	17-5
Cleaning	17-3d	17-4
Disassembly	17-3c	17-3
Inspection and repair	17-3e	17-4
Preliminary procedure	17-3a	17-1
Removal	17-3b	17-2
Replacement	17-3g	17-6
Hose compartment door	17-20	17-175
Hose, water dispenser, repair	20-5	20-1
Cleaning	20-5b	20-1
Inspection and repair	20-5c	20-2
Preliminary procedures	20-5a	20-1

INDEX - CONT

Subject	Paragraph	Page
L		
Lamp support bracket (early model trucks)	19-8	19-23
Cleaning	19-8c	19-27
Inspection and repair	19-8d	19-27
Preliminary procedures	19-8a	19-23
Removal	19-8b	19-24
Replacement	19-8e	19-28
Lamp support bracket (late model trucks)	19-9	19-31
Cleaning	19-9c	19-36
Inspection and repair	19-9d	19-36
Preliminary procedures	19-9a	19-31
Removal	19-9b	19-32
Replacement	19-9e	19-37
Lifting shackle (trucks M109A2, M109A3, M185A2, and M185A3)	17-41	17-418
Left front lifting shackle	17-41b	17-419
Left rear lifting shackle	17-41e	17-439
Preliminary procedures	17-41a	17-418
Right front lifting shackle	17-41c	17-425
Right rear lifting shackle	17-41d	17-429
M		
Manifolds, exhaust, and air intake	2-21	2-205
O		
Oil cooler, bypass valve	2-20	2-203
Inspection and repair	2-20c	2-204
Preliminary procedure	2-20a	2-203
Removal	2-20b	2-203
Replacement	2-20d	2-204
Oil cooler, radiator	2-18	2-189
Preliminary procedures	2-18a	2-189
Removal	2-18b	2-189
Replacement	2-18c	2-193
Oil pressure regulator	2-19	2-197
Cleaning, inspection, and repair	2-19c	2-200
Preliminary procedure	2-19a	2-197
Removal	2-19b	2-198
Replacement	2-19d	2-200
Oil pump assembly, lubricating	2-17	2-169
Assembly	2-17f	2-181
Cleaning	2-17d	2-179
Disassembly	2-17c	2-175
Inspection and repair	2-17e	2-179

INDEX - CONT

Subject	Paragraph	Page
O - Cont		
Preliminary procedure	2-17a	2-169
Removal	2-17b	2-170
Replacement	2-17g	2-185
Oil seals, power divider input and rear output shaft (truck M764)	18-11	18-218
Cleaning	18-11b	18-221
Removal	18-11a	18-219
Replacement	18-11c	18-222
Operator's seat, earth boring machine	17-44	17-472
P		
Painting, general procedures	1-4	1-2
Pipeline construction truck body	17-64	17-754
Cleaning	17-64c	17-758
Inspection and repair	17-64d	17-758
Preliminary procedure	17-64a	17-754
Removal	17-64b	17-755
Replacement	17-64e	17-759
Pistons and connecting rod assembly	2-13	2-132
Poppet valve pushrod	2-14	2-132
Preliminary procedure	2-14a	2-132
Removal	2-14b	2-133
Replacement	2-14c	2-137
Power divider (truck M764)	18-12	18-224
Assembly	18-12f	18-250
Cleaning	18-12d	18-245
Disassembly	18-12c	18-230
Inspection and repair	18-12e	18-245
Preliminary procedures	18-12a	18-224
Removal	18-12b	18-225
Replacement	18-12g	18-269
Powerplant heater	21-6	21-16
Powerplant heater test	21-5	21-2
Pump compartment door (trucks M49A1C and M49A2C)	17-19	17-165
Pump compartment door (trucks M50A1, M50A2, and M50A3)	17-31	17-360
Assembly	17-31e	17-366
Cleaning	17-31c	17-365
Disassembly	17-31b	17-361
Inspection and repair	17-31d	17-365
Removal	17-31a	17-360
Replacement	17-31f	17-369

INDEX - CONT

Subject	Paragraph	Page
R		
Radiator brush guard	19-5	19-12
Assembly	19-5f	19-15
Cleaning	19-5d	19-13
Disassembly	19-5c	19-13
Inspection and repair	19-5e	19-14
Preliminary procedures	19-5a	19-12
Removal	19-5b	19-12
Replacement	19-5g	19-16
Radiator repair and test	6-3	6-1
Radiator shroud repair	6-4	6-1
Rear door hinges (trucks M109A2 and 109A3)	17-38	17-397
Preliminary procedures	17-38a	17-397
Removal	17-38b	17-397
Replacement	17-38c	17-399
Rear suspension system	11-7	11-23
Running board, left, gasoline drum bracket, and tool box (all trucks except M275A1 and M275A2)	17-10	17-115
Assembly	17-10f	17-116
Cleaning	17-10c	17-116
Disassembly	17-10b	17-115
Inspection	17-10d	17-116
Preliminary procedure	17-10a	17-115
Repair	17-10e	17-116
Running board, right, and battery box	17-9	17-102
Cleaning	17-9c	17-108
Inspection and repair	17-9d	17-108
Preliminary procedure	17-9a	17-102
Removal	17-9b	17-102
Replacement	17-9e	17-109

S

Safety inspection	1-7	1-2
Sash, front	17-39	17-401
Assembly	17-39f	17-407
Cleaning	17-39d	17-404
Disassembly	17-39c	17-403
Inspection and repair	17-39e	17-405
Preliminary procedure	17-39a	17-401
Removal	17-39b	17-402
Replacement	17-39g	17-408
Sash, side, with panel and window assembly	17-40	17-409
Assembly	17-40e	17-414
Cleaning	17-40c	17-413
Disassembly	17-40b	17-412

INDEX - CONT

Subject	Paragraph	Page
S - Cont		
Inspection and repair	17-40d	17-413
Removal	17-40a	17-409
Replacement	17-40f	17-415
Scope of manual	1-1	1-1
Seat, companion, (early model)	17-14	17-134
Seat, companion, (late model)	17-15	17-139
Seat, driver's, early model	17-13	17-131
Seat, driver's, floating	17-12	17-122
Seat, operator's, earth boring machine	17-44	17-472
Segregator (truck M49A2C)	17-22	17-188
Preliminary procedure	17-22a	17-188
Removal	17-22b	17-188
Replacement	17-22c	17-193
Slave receptacle kit installation	21-18	21-140
Special tools and equipment	1-6	1-2
Splash shield	17-69	17-832
Cleaning	17-69b	17-851
Inspection and repair	17-69c	17-851
Removal	17-69a	17-832
Replacement	17-69d	17-852
Spring seat, rear, drilling and tapping for lubrication	16-3	16-1
Installation of lubrication plug	16-3a	16-2
Lubrication of rear spring seat	16-3b	16-4
Steering arm, front axle, repair	10-9	10-107
Steering gear check level plug installation	14-4	14-46
Preliminary procedure	14-4a	14-46
Removal	14-4b	14-46
Replacement	14-4c	14-48
Steering gear, mechanical	14-3	14-1
Assembly	14-3f	14-26
Cleaning	14-3d	14-20
Disassembly	14-3c	14-11
Inspection and repair	14-3e	14-20
Preliminary procedures	14-3a	14-1
Removal	14-3b	14-2
Replacement	14-3g	14-37
Step plate and tool box	17-63	17-751
Assembly	17-63e	17-753
Cleaning	17-63c	17-752
Disassembly	17-63b	17-751
Inspection and repair	17-63d	17-752
Preliminary procedure	17-63a	17-751

INDEX - CONT

Subject	Paragraph	Page
S - Cont		
Suspension system, rear, repair	11-7	11-23
Assembly	11-7g	11-33
Cleaning	11-7e	11-32
Disassembly	11-7d	11-26
Inspection and cleaning before disassembly	11-7c	11-26
Inspection and repair	11-7f	11-32
Preliminary procedures	11-7a	11-23
Removal	11-7b	11-24
Replacement	11-7h	11-33
T		
Tank body discharge valve with screen	17-25	17-222
Assembly	17-25f	17-228
Cleaning	17-25c	17-224
Disassembly	17-25b	17-222
Inspection	17-25d	17-224
Preliminary procedure	17-25a	17-222
Repair	17-25e	17-226
Tank body door holder	17-21	17-180
Adjustment	17-21g	17-187
Assembly	17-21e	17-184
Cleaning	17-21c	17-183
Disassembly	17-21b	17-181
Inspection and repair	17-21d	17-183
Removal	17-21a	17-180
Replacement	17-21f	17-186
Tank body hose compartment door, repair	17-20	17-175
Assembly	17-20e	17-178
Cleaning	17-20c	17-177
Disassembly	17-20b	17-176
Inspection and repair	17-20d	17-177
Removal	17-20a	17-175
Replacement	17-20f	17-199
Tank body pump compartment door (trucks M49A1C and M49A2C)	17-19	17-165
Assembly	17-19e	17-171
Cleaning	17-19c	17-170
Disassembly	17-19b	17-166
Inspection and repair	17-19d	17-170
Removal	17-19a	17-165
Replacement	17-19f	17-174
Testing of lifting devices	1-7	1-2
Tire repair	13-4	13-3
Torque values	1-5	1-2

INDEX - CONT

Subject	Paragraph	Page
T - Cont		
Trailer air brake hand control valve repair	12-7	12-59
Transmission, removal	8-4	8-24
Preliminary procedures	8-4a	8-24
Removal	8-4b	8-25
Replacement	8-4c	8-27
Transmission cover	8-3	8-1
Assembly	8-3f	8-14
Cleaning	8-3d	8-12
Disassembly	8-3c	8-6
Inspection and repair	8-3e	8-12
Preliminary procedure	8-3a	8-1
Removal	8-3b	8-2
Replacement	8-3g	8-20
Transmission power takeoff controls and linkage repair	18-15	18-277
Transmission transfer, air actuated, removal	9-3	9-1
Preliminary procedures	9-3a	9-1
Removal	9-3b	9-2
Replacement	9-3c	9-5
Transmission transfer, air actuated, repair	9-4	9-8
Transmission transfer, double sprag, repair	9-5	9-8
Preliminary procedures	9-5a	9-8
Removal	9-5b	9-9
Repair	9-5c	9-11
Replacement	9-5d	9-11
Transmission transfer, power takeoff	18-16	18-277
Preliminary procedure	18-16a	18-277
Removal	18-16b	18-278
Repair	18-16c	18-280
Replacement	18-16d	18-280
Transmission transfer, power takeoff controls and linkage repair	18-17	18-282
Turbocharger repair	4-6	4-6

V

Van body	17-43	17-459
Assembly	17-43f	17-466
Cleaning	17-43d	17-465
Disassembly	17-43c	17-464
Inspection and repair	17-43e	17-465
Preliminary procedures	17-43a	17-459
Removal	17-43b	17-460
Replacement	17-43g	17-467

INDEX - CONT

Subject	Paragraph	Page
V - Cont		
Van heater, primary	21-13	21-119
Van heater, secondary	21-14	21-119
Van wiring harness, main	7-11	7-36
Van wiring harness, 24-volt	7-12	7-40
W		
Water discharge pipe (trucks M50A2 and M50A3)	17-33	17-375
Cleaning, inspection, and repair	17-33b	17-375
Preliminary procedure	17-33a	17-375
Water Segregator (Truck M49A2C)	17-22	17-188
Preliminary Procedure	17-22a	17-188
Removal	17-22b	17-188
Replacement	17-22c	17-193
Water Segregator Filter (Truck M49A2C)	17-23	17-197
Assembly	17-23f	17-202
Cleaning	17-23d	17-202
Disassembly	17-23c	17-202
Inspection and Repair	17-23e	17-202
Preliminary Procedure	17-23a	17-197
Removal	17-23b	17-197
Replacement	17-23g	17-202
Water tank bodies (trucks M50A1, M50A2, and M50A3)	17-30	17-339
Assembly	17-30f	17-352
Cleaning	17-30d	17-349
Disassembly	17-30c	17-342
Inspection and repair	17-30e	17-350
Preliminary procedures	17-30a	17-339
Removal	17-30b	17-340
Replacement	17-30g	17-357
Water tank nozzle	17-32	17-370
Assembly	17-32e	17-373
Cleaning	17-32c	17-372
Disassembly	17-32b	17-370
Inspection and repair	17-32d	17-372
Preliminary procedure	17-32a	17-370
Wheel hub spindle, front	10-10	10-114
Cleaning	10-10c	10-116
Inspection and repair	10-10d	10-116
Preliminary procedure	10-10a	10-114
Removal	10-10b	10-115
Replacement	10-10e	10-117
Wheel repair	13-3	13-1
Cleaning	13-3b	13-2
Inspection and repair	13-3c	13-2
Preliminary procedures	13-3a	13-1

INDEX - CONT

Subject	Paragraph	Page
W - Cont		
Winch, front	18-3	18-1
Cleaning	18-3c	18-15
Disassembly	18-3b	18-2
Inspection and repair	18-3d	18-15
Preliminary procedures	18-3a	18-1
Winch, front, transmission, power takeoff	18-13	18-274
Preliminary procedures	18-13a	18-274
Removal	18-13b	18-275
Replacement	18-13c	18-276
Winch, front, transmission, power takeoff repair	18-14	18-277
Winch, rear (truck M756A2)	18-4	18-34
Assembly	18-4f	18-54
Cleaning	18-4d	18-47
Disassembly	18-4c	18-37
Inspection and repair	18-4e	18-47
Preliminary procedure	18-4a	18-34
Removal	18-4b	18-35
Replacement	18-4g	18-66
Test	18-4h	18-68
Winch, rear (truck M764)	18-5	18-70
Assembly	17-5f	18-113
Cleaning	18-5d	18-99
Disassembly	18-5c	18-73
Inspection and repair	18-5e	18-99
Preliminary procedures	18-5a	18-70
Removal	18-5b	18-71
Replacement	18-5g	18-146
Testing	18-5h	18-148
Winch, rear, drive chain (truck M764)	18-6	18-154
Adjustment	18-6c	18-168
Removal	18-6a	18-154
Replacement	18-6b	18-161
Wiring harness, chassis, (trucks M275A1 and M275A2)	7-8	7-17
Preliminary procedures	7-8a	7-17
Removal	7-8b	7-18
Replacement	7-8c	7-23
Wiring harness, front (all trucks except M275A1 and M275A2)	7-6	7-4
Preliminary procedures	7-6a	7-4
Removal	7-6b	7-5
Replacement	7-6c	7-9
Wiring harness, rear	7-7	7-13
Preliminary procedure	7-7a	7-13
Removal	7-7b	7-13
Replacement	7-7c	7-15

INDEX - CONT

Subject	Paragraph	Page
W - Cont		
Wiring harness clamps, chassis	7-5	7-2
Removal	7-5a	7-2
Replacement	7-5b	7-3
Wiring harnesses, clearance light	7-9	7-28
Preliminary procedure	7-9a	7-28
Removal	7-9b	7-29
Replacement	7-9c	7-31
Wiring harness, floodlight	7-10	7-33
Preliminary procedure	7-10a	7-33
Removal	7-10b	7-33
Replacement	7-10c	7-34
Wiring harness, van, main	7-11	7-36
Preliminary procedures	7-11a	7-36
Removal	7-11b	7-36
Replacement	7-11c	7-38
Wiring harness, van, 24-volt	7-12	7-40
Preliminary procedure	7-12a	7-40
Removal	7-12b	7-40
Replacement	7-12c	7-41

By Order of the Secretaries of the Army and the Air Force:

E. C. MEYER
General, United States Army
Chief of Staff

Official:

J. C. PENNINGTON
Major General, United States Army
The Adjutant General

LEW ALLEN, JR., General, USAF
Chief of Staff

Official:

VAN L. CRAWFORD, JR., Colonel, USAF
Director of Administration

Distribution:

To be distributed in accordance with DA Form 12-38, Direct and General Support
Maintenance requirements for 2-1/2 Ton Truck Cargo, 2-1/2 Ton Truck Van, etc.



THEN... JOT DOWN THE DOPE ABOUT IT ON THIS FORM, CAREFULLY TEAR IT OUT, FOLD IT AND DROP IT IN THE MAIL!

SOMETHING WRONG WITH THIS PUBLICATION?

FROM (PRINT YOUR UNIT'S COMPLETE ADDRESS)

CDR, 1st Bn, 65th ADA
Attn: SP4 Jane Idone
Key West, FL 33040

DATE SENT

Date sent in

PUBLICATION NUMBER

TM 9-2320-209-34-2-3

PUBLICATION DATE

20 May 1981

PUBLICATION TITLE

DIR. & GEN. SUPPORT
MAINT. MANUAL

BE EXACT... PIN-POINT WHERE IT IS

PAGE NO	PARA-GRAPH	FIGURE NO	TABLE NO
18-2	18-3 b		
18-49		18-6	
19-5	19-3 f		

IN THIS SPACE TELL WHAT IS WRONG AND WHAT SHOULD BE DONE ABOUT IT:

FRAME 1, change illustration callouts.
Reason: callouts for top tension channel (2) and rear tension channel (4) are reversed.

Item 1, wear limit reads "None." Should read "0.015."

FRAME 1, step 4 reads "Put in three screws and self-locking nuts." Should read "Put in five screws and self-locking nuts (4)."

SAMPLE

PRINTED NAME GRADE OR TITLE AND TELEPHONE NUMBER

SP4 Jane Idone Autovon 222-2224

SIGN HERE

Jane Idone

FILL IN YOUR
UNIT'S ADDRESS

FOL

DEPARTMENT OF THE ARMY

OFFICIAL BUSINESS
PENALTY FOR PRIVATE USE \$.

POSTAGE AND FEES PAID
DEPARTMENT OF THE ARMY
DOD 314



SAMPLE

TEAR ALONG PERFORATED LINE

Commander
U.S. Army Tank-Automotive Command
ATTN: DRSTA-MB
Warren, MI 48090

FILL IN YOUR
UNIT'S ADDRESS

FOLD BACK

DEPARTMENT OF THE ARMY

OFFICIAL BUSINESS
PENALTY FOR PRIVATE USE \$300

POSTAGE AND FEES PAID
DEPARTMENT OF THE ARMY
DOD 314



COMMANDER
U.S. ARMY TANK – AUTOMOTIVE
MATERIEL READINESS COMMAND
ATTN: DRSTA-MB
WARREN, MI 48090

TEAR ALONG PERFORATED LINE

FILL IN YOUR
UNIT'S ADDRESS

FOLD BACK

DEPARTMENT OF THE ARMY

OFFICIAL BUSINESS
PENALTY FOR PRIVATE USE \$300

POSTAGE AND FEES PAID
DEPARTMENT OF THE ARMY
DOD 314



COMMANDER
U.S. ARMY TANK – AUTOMOTIVE
MATERIEL READINESS COMMAND
ATTN: DRSTA-MB
WARREN, MI 48090

TEAR ALONG PERFORATED LINE

RECOMMENDED CHANGES TO EQUIPMENT TECHNICAL PUBLICATIONS



THEN... JOT DOWN THE DOPE ABOUT IT ON THIS FORM. CAREFULLY TEAR IT OUT. FOLD IT AND DROP IT IN THE MAIL.

SOMETHING WRONG WITH THIS PUBLICATION?

FROM: (PRINT YOUR UNIT'S COMPLETE ADDRESS)

DATE SENT

PUBLICATION NUMBER

TM 9-2320-209-34-2-3

PUBLICATION DATE

20 May 1981

PUBLICATION TITLE

DIR. & GEN. SUPPORT
MAINT. MANUAL

BE EXACT PIN-POINT WHERE IT IS

PAGE
NO

PARA-
GRAPH

FIGURE
NO

TABLE
NO

IN THIS SPACE TELL WHAT IS WRONG
AND WHAT SHOULD BE DONE ABOUT IT:

PRINTED NAME GRADE OR TITLE AND TELEPHONE NUMBER

SIGN HERE

FILL IN YOUR
UNIT'S ADDRESS

FOLD BACK

DEPARTMENT OF THE ARMY

OFFICIAL BUSINESS
PENALTY FOR PRIVATE USE \$300

POSTAGE AND FEES PAID
DEPARTMENT OF THE ARMY
DOD 314



TEAR ALONG PERFORATED LINE

COMMANDER
U.S. ARMY TANK – AUTOMOTIVE
MATERIEL READINESS COMMAND
ATTN: DRSTA-MB
WARREN, MI 48090

THE METRIC SYSTEM AND EQUIVALENTS

LINEAR MEASURE

1 Centimeter = 10 Millimeters = 0.01 Meters = 0.3937 Inches
 1 Meter = 100 Centimeters = 1000 Millimeters = 39.37 Inches
 1 Kilometer = 1000 Meters = 0.621 Miles

WEIGHTS

1 Gram = 0.001 Kilograms = 1000 Milligrams = 0.035 Ounces
 1 Kilogram = 1000 Grams = 2.2 Lb
 1 Metric Ton = 1000 Kilograms = 1 Megagram = 1.1 Short Tons

LIQUID MEASURE

1 Milliliter = 0.001 Liters = 0.0338 Fluid Ounces
 1 Liter = 1000 Milliliters = 33.82 Fluid Ounces

SQUARE MEASURE

1 Sq Centimeter = 100 Sq Millimeters = 0.155 Sq Inches
 1 Sq Meter = 10,000 Sq Centimeters = 10.76 Sq Feet
 1 Sq Kilometer = 1,000,000 Sq Meters = 0.386 Sq Miles

CUBIC MEASURE

1 Cu Centimeter = 1000 Cu Millimeters = 0.06 Cu Inches
 1 Cu Meter = 1,000,000 Cu Centimeters = 35.31 Cu Feet

TEMPERATURE

$5/9 (^{\circ}\text{F} - 32) = ^{\circ}\text{C}$
 212^o Fahrenheit is equivalent to 100^o Celsius
 90^o Fahrenheit is equivalent to 32.2^o Celsius
 32^o Fahrenheit is equivalent to 0^o Celsius
 $9/5 C^{\circ} + 32 = F^{\circ}$

APPROXIMATE CONVERSION FACTORS

<u>TO CHANGE</u>	<u>TO</u>	<u>MULTIPLY BY</u>
Inches	Centimeters	2.540
Feet	Meters	0.305
Yards	Meters	0.914
Miles	Kilometers	1.609
Square Inches	Square Centimeters	6.451
Square Feet	Square Meters	0.093
Square Yards	Square Meters	0.836
Square Miles	Square Kilometers	2.590
Acres	Square Hectometers	0.405
Cubic Feet	Cubic Meters	0.028
Cubic Yards	Cubic Meters	0.765
Fluid Ounces	Milliliters	29.573
Pints	Liters	0.473
Quarts	Liters	0.946
Gallons	Liters	3.785
Ounces	Grams	28.349
Pounds	Kilograms	0.454
Short Tons	Metric Tons	0.907
Pound-Feet	Newton-Meters	1.356
Pounds per Square Inch	Kilopascals	6.895
Miles per Gallon	Kilometers per Liter	0.425
Miles per Hour	Kilometers per Hour	1.609

<u>TO CHANGE</u>	<u>TO</u>	<u>MULTIPLY BY</u>
Centimeters	Inches	0.394
Meters	Feet	3.280
Meters	Yards	1.094
Kilometers	Miles	0.621
Square Centimeters	Square Inches	0.155
Square Meters	Square Feet	10.764
Square Meters	Square Yards	1.196
Square Kilometers	Square Miles	0.386
Square Hectometers	Acres	2.471
Cubic Meters	Cubic Feet	35.315
Cubic Meters	Cubic Yards	1.308
Milliliters	Fluid Ounces	0.034
Liters	Pints	2.113
Liters	Quarts	1.057
Liters	Gallons	0.264
Grams	Ounces	0.035
Kilograms	Pounds	2.205
Metric Tons	Short Tons	1.102
Newton-Meters	Pound-Feet	0.738
Kilopascals	Pounds per Square Inch	0.145
Kilometers per Liter	Miles per Gallon	2.354
Kilometers per Hour	Miles per Hour	0.621

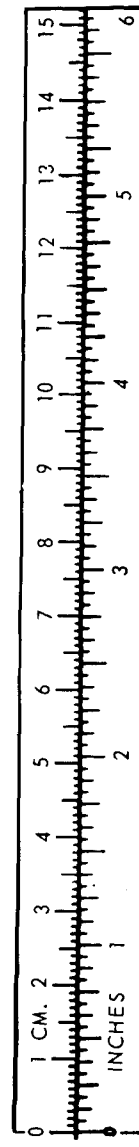

TAO89991

