

TM 5-4930-207-12

DEPARTMENT OF THE ARMY TECHNICAL MANUAL

OPERATOR AND ORGANIZATIONAL MAINTENANCE MANUAL

LUBRICATING AND SERVICING UNIT,
POWER OPERATED, TRAILER MOUNTED,
23 CFM COMPRESSOR, RECIPROCATING,
GASOLINE DRIVEN (HENRY SPEN MODEL 901765-1)
FSN 4930-017-9167



HEADQUARTERS, DEPARTMENT OF THE ARMY

21 APRIL 1970

WARNING

TIRE INFLATION

When inflating tires remain to one side of the tire rather than directly in front of it. Serious injury may result if the tire blows out, or if the rim is forced off.

POISONOUS GAS

Do not operate the engine in a closed area unless the exhaust is piped into the atmosphere. Exhaust gases contain carbon monoxide, a colorless, odorless, deadly poison gas.

HIGH PRESSURE AIR

Care must be observed when using high pressure air as small particles of dust or dirt blown out could cause bodily injury.

CHANGE
NO. 4

HEADQUARTERS,
DEPARTMENT OF THE ARMY
WASHINGTON, D. C., 10 OCTOBER 1990

**Operator and Organizational
Maintenance Manual**

**LUBRICATING AND SERVICING UNIT,
POWER OPERATED, TRAILER MOUNTED,
23 CFM COMPRESSOR, RECIPROCATING,
GASOLINE DRIVE (HENRY SPEN MODEL 901765-1)
FSN 4930-017-9167**

Approved for public release; distribution is unlimited

TM 5J1930-207-12, dated 21 April 1970, is changed as follows:

Page 1-1, paragraph 1- 1d, address is changed to:

US ARMY TROOP SUPPORT COMMAND,
ATTN: AMSTR-MCTS
4300 Goodfellow Blvd., St. Louis, MO 63120-1798

Page 2-3, paragraph 2-2f, add note:

NOTE

Use an electrolyte with a specific gravity of 1.280. Do not use tropical electrolyte, which will reduce battery reserve capacity.

Page 2-3, paragraph 2-3a, add note:

NOTE

Use an electrolyte with a specific gravity of 1.280. Do not use tropical electrolyte, which will reduce battery reserve capacity.

Page 2-22, paragraph 2-1 8, add "c."

c. Increase battery PMCS frequency. Use distilled water or a good grade drinking water (excluding mineral water)

By Order of the Secretary of the Army :

CARL E. VUONO
General, United States Army
Chief of Staff

Official:

THOMAS F. SIKORA
Brigadier General, United States Army
The Adjutant General

DISTRIBUTION:

To be distributed in accordance with DA Form 12-25E, (qty rqr block no. 1171)

* U.S. GOVERNMENT PRINTING OFFICE: 1991 554-123/20122

Change: }
No. 3 }

HEADQUARTERS
DEPARTMENT OF THE ARMY
Washington, D.C., 24 June 1974

**Operator and Organizational Maintenance Manual
LUBRICATING AND SERVICING UNIT, POWER OPERATED,
TRAILER MOUNTED 23 CFM COMPRESSOR, RECIPROCATING,
GASOLINE DRIVEN (HENRY SPEN MODEL 901765-1)
FSN 4930-017-9167**

TM 5-4930-207-12, 21 April 1970, is changed as follows:

Inside Front Cover. Add the following warnings to the inside front cover:

WARNING

Operation of this equipment presents a noise hazard to personnel in the area. The noise level exceeds the allowable limits for unprotected personnel. Wear ear muffs or ear plugs which were fitted by a trained professional.

WARNING

Drycleaning solvent, P-D-680, used to clean parts is potentially dangerous to personnel and property. Do not use near open flame or excessive heat. Flash point of solvent is 100° F. - 138° F.

Page 2-1. Immediately after chapter 2 title, add the following:

WARNING

Operation of this equipment presents a noise hazard to personnel in the area. The noise level exceeds the allowable limits for unprotected personnel. Wear ear muffs or ear plugs which were fitted by a trained professional.

Page 4-35. Immediately after paragraph 4-37 title, add the following

WARNING

Drycleaning solvent, P-D-680, used to clean parts is potentially dangerous to personnel and property. Do not use near open flame or excessive heat. Flash point of solvent is 100° F. - 138° F.

Page 4-36, paragraph 4-37c (1), line 2, change "kerosene" to read "cleaning solvent, P-D-680."

Page A-1, paragraph A-2. Delete "LO 5-2330-216-15" in its entirety.

Paragraph A-5, add the following reference: TB MED 251, Noise and Conservation of Hearing.

By Order of the Secretary of the Army:

CREIGHTON W. ABRAMS
General, United States Army
Chief of Staff

Official:

VERNE L. BOWERS
Major General, United States Army
The Adjutant General

Distribution:

To be distributed in accordance with DA Form 12-25A, (qty rqr block No. 137) Operator maintenance requirements for Lubricating and Servicing.

*U.S. GOVERNMENT PRINTING OFFICE: 1974-768119/1893

CHANGE }
No. 2 }

HEADQUARTERS
DEPARTMENT OF THE ARMY
WASHINGTON, D. C., .30 October 1972

Operator and Organizational Maintenance Manual
LUBRICATING AND SERVICING UNIT,
POWER OPERATED, TRAILER MOUNTED,
23 CFM COMPRESSOR, RECIPROCATING,
GASOLINE DRIVE (HENRY SPEN MODEL 901765-1)
FSN 4930-017-9167

TM 5-4930-207-12, 21 April 1970, is changed as follows:

Page 2-3. Paragraph 2-2*h* is added as follows:

h. Maintenance and operating supplies required for initial 8 hours of operation are listed in table 2-0.

Table 2-0. MAINTENANCE AND OPERATING SUPPLIES

(1) Component Application	(2) Federal Stock Number	(3) Description	(4) Quantity Required F/Initial Operation	(5) Quantity Required F/8 Hrs Operation	(6) Notes
FUEL TANK	9130-160-1818 9130-160-1830	FUEL, GASOLINE: Bulk as follows: Automotive combat, type I Automotive combat, type II	10 gal (4) 10 gal (4)	(5) (5)	(1) Includes quantity of oil to fill compressor oil system as follows: 2 qt. compressor
ALCOHOL DISPENSER	6810-264-6583	ALCOHOL, DENATURED: 1 qt. bottl as follows: Alcohol	¼ qt		(2) See FSC C9100-IL for additional data and requisitioning procedures.
CRANKCASE	9150-265-9437(2) 9150-265-9430(2) 9150-242-7605(2)	OIL, LUBRICATING: 55 gal. drum as follows: OE-30 OE-10 OES	2 qt 2 qt 2 qt	(3) (3) (3)	(3) See current lubrication chart for grade application and replenishment intervals. (4) Tank capacity. (5) See TM 5-2805-203-14 for average fuel consumption.
LUBRICATING OIL RESERVOIR	9150-265-9437(2) 9150-265-9430(2) 9150-242-7605(2)	OIL, LUBRICATING: 55 gal. drum as follows: OE-30 OE-10 OES	27 gal 27 gal 27 gal	(6) (6) (6)	(6) Quantity of oil to fill oil reservoir. (7) Quantity of gear oil to fill reservoir.
LUBRICATING GEAR OIL RESERVOIR	9150-577-5846(2) 9150-257-5443(2)	LUBRICATING OIL, GEAR: 55 gal. drum as follows: GO-90 GOS	27 gal 27 gal	(7) (7)	(8) 2 ea—100-lb. drums are required to fill grease reservoir.
LUBRICATING GREASE RESERVOIR	9150-530-7369	GREASE, AUTOMOTIVE AND AR- TILLERY: 120 lb. drum as follows: GAA	175 lb.	(8)	

APPENDIX C
BASIC ISSUE ITEMS LIST AND ITEMS
TROOP INSTALLED OR AUTHORIZED

Section I. INTRODUCTION

C-1. Scope

This appendix lists items required by the operator for operation of the lubricating and servicing unit.

C-2. General

This list is divided into the following sections:

a. Basic Issue Items List-Section II. Not applicable.

b. Items Troop Installed or Authorized List—Section III. A list of items in alphabetical sequence, which at the discretion of the unit commander may accompany the lubricating and servicing unit. These items are NOT subject to turn-in with the lubricating and servicing unit when evacuated.

C-3. Explanation of Columns

The following provides an explanation of columns in the tabular list of Basic Issue Items List, Section II, and Items Troop Installed or Authorized, Section III.

a. Source, Maintenance, and Recoverability Code(s) (SMR):

(1) Source Code, indicates the source for the listed item. Source codes are:

<i>Code</i>	<i>Explanation</i>
P	Repair parts, special tools and test equipment supplied from GSA/DSA or Army supply system and authorized for use at indicated maintenance levels.
P2	Repair parts, special tools and test equipment which are procured and stocked for insurance purposes because the combat or military essentiality of the end item dictates that a minimum quantity be available in the supply system.

(2) Maintenance Code, indicates the lowest level of maintenance authorized to install the listed item. The maintenance level code is:

<i>Code</i>	<i>Explanation</i>
C	Crew/Operator

(3) Recoverability Code, indicates whether unserviceable items should be returned for recovery or salvage. Items not coded are non-recoverable. Recoverability codes are:

<i>Code</i>	<i>Explanation</i>
R	Applied to repair parts (assemblies and components), special tools and test equipment which are considered economically repairable at direct and general support maintenance levels.
S	Repair parts, special tools, test equipment and assemblies which are economically repairable at DSU and GSU activities and which normally are furnished by supply on an exchange basis.

b. Federal Stock Number. This column indicates the Federal Stock Number assigned to the item and will be used for requisitioning purposes.

c. Description. This column indicates the Federal item name and any additional description of the item required.

d. Unit of Measure (U/M). A 2 character alphabetic abbreviation indicating the amount or quantity of the item upon which the allowances are based, e.g., ft, ea, pr, etc.

e. Quantity Furnished With Equipment (BIIL only). This column indicates the quantity of an item furnished with the equipment.

f. Quantity Authorized (Items Troop Installed or Authorized Only). This column indicates the quantity of the item authorized to be used with the equipment.

g. Illustration (BIIL only). This column is divided as follows:

(1) *Figure number.* Indicates the figure number of the illustration in which the item is shown,

(2) *Item number.* Indicates the callout number used to reference the item in the illustration.

Section III. ITEMS TROOP INSTALLED OR AUTHORIZED LIST

(1) SMR Code	(2) Federal Stock Number	Ref No. & Mfr Code	(3) Description	(4) Unit of Meas	(5) Qty Auth
PC	7520-559-9618		CASE, MAINTENANCE AND OPERATION MANUALS	EA	

By Order of the Secretary of the Army:

CREIGHTON W. ABRAMS
General, United States Army
Chief of Staff

Official:

VERNE L. BOWERS
Major General, United States Army
The Adjutant General

Distribution:

To be distributed in accordance with DA Form 12-25A (qty rqr block No, 137) operator maintenance requirements for Lubricating and Servicing.

CHANGE }
NO. 1 }

HEADQUARTERS
DEPARTMENT OF THE ARMY
Washington, D. C., 10 December 1970)

Operator and Organizational Maintenance Manual

LUBRICATING AND SERVICING UNIT, POWER OPERATED, TRAILER MOUNTED, 23 CFM COMPRESSOR, RECIPROCATING, GASOLINE DRIVEN (HENRY SPEN MODEL 901765-1) FSN 4930-017-9167

TM 5-4930-207-12, 21 April 1970, is changed as follows:

Page 2-3. Paragraphs 2-3*b* and 2-3*c* are superseded as follows:

b. When batteries are filled, remove six hex head cap screws with washers, remove battery hold down device, and install the batteries in the battery drawer.

c. Install cables and reinstall the battery holddown device. Make sure the negative ground cable is installed on the negative battery post.

WARNING

Clean any spilled electrolyte with water. Keep electrolyte off skin to prevent personnel injury.

Page 2-3. Figure 2-3 is deleted.

By Order of the Secretary of the Army:

**W. C. WESTMORELAND,
General, United States Army,
Chief of Staff**

Official:

**KENNETH G. WICKHAM,
Major General, United States Army,
The Adjutant General.**

Distribution:

To be distributed in accordance with DA Form 12-25, Sec I (qty rqr Block #137), Operator requirements for Lubricating and Servicing Equipment.

* U.S. GOVERNMENT PRINTING OFFICE: 1970-4311 25/608

Technical Manual

No. 5-4930-207-12

HEADQUARTERS
DEPARTMENT OF THE ARMY
Washington, D.C., 21 April 1970

OPERATOR AND ORGANIZATIONAL MAINTENANCE MANUAL

LUBRICATING AND SERVICING UNIT, POWER OPERATED,
TRAILER MOUNTED, 23 CFM COMPRESSOR, RECIPROCATING,
GASOLINE DRIVEN (HENRY SPEN MODEL 901 765-1)
FSN 4930-017-9167

	Paragraph	Page
Chapter 1. INTRODUCTION		
Section I. General	1-1 - 1-3	1-1
II. Description and data	1-4- 1-6	1-1
Chapter 2. INSTALLATION AND OPERATING INSTRUCTIONS		
Section I. Service upon receipt of equipment	2-1 - 2-4	2-1
II. Movement to a new worksite	2-5, 2-6	2-4
III. Controls and instruments	2-7, 2-8	2-4
IV. operation under usual conditions	2-9-2-16	2-8
V. Operation under unusual conditions	2-17 - 2-22	2-21
VI. Operation of material used in conjunction with the equipment	2-23 - 2-29	2-23
Chapter 3. OPERATOR'S MAINTENANCE INSTRUCTIONS		
Section I. Operator's and organizational maintenance, tools and equipments	3-1 - 3-3	3-1
II. Lubrication instruction	3-4, 3-5	3-1
III. Operator's preventive maintenance checks and services	3-6, 3-7	3-1
IV. Operator's troubleshooting	3-8, 3-9	3-2
IV. Operator's maintenance	3-10 - 3-19	3-4
Chapter 4. ORGANIZATIONAL MAINTENANCE INSTRUCTIONS		
Section I. Organizational preventive maintenance services	4-1, 4-2	4-1
II. Organizational maintenance troubleshooting	4-3, 4-4	4-2
III. Enclosure assembly, battery and accessory drawers and tool box	4-5 - 4-8	4-4
IV. Electrical system	4-9- 4-18	4-6
V. Fuel and exhaust system	4-19 - 4-21	4-15
VI. Compressor assembly and air lines	4-22 - 4-27	4-18
VII. Air lubrication system	4-28 - 4-35)	4-22
VIII. Engine and clutch	4-36 - 4-38	4-35
IX. Trailer wheels and brakes	4-39 - 4-48	
X. Trailer frame	4-49 - 4-56	4-47
Appendix A. REFERENCES	A-1	A-1
B. MAINTENANCE ALLOCATION CHART	B-1	B-1
C. BASIC ISSUE ITEMS LIST	C-1	C-1
Alphabetical		
Index		I-1

* This manual supersedes TM 5-4930-207-12, 23 May 1966, including all changes.

LIST OF ILLUSTRATIONS

<i>Figure Number</i>	<i>Title</i>	<i>Page</i>
1-1	Lubricating unit, right rear, $\frac{3}{4}$ view.	1-2
1-2	Lubricating unit, left front, $\frac{3}{4}$ view.	1-3
1-3	Trailer assembly, left front, $\frac{3}{4}$ view.	1-5
1-4	Trailer assembly, left rear, $\frac{3}{4}$ view.	1-6
1-5	Trailer schematic wiring diagram.	1-8
1-6	Hydraulic brake system schematic diagram	1-9
1-7	Lubricator schematic wiring diagram.	1-10
2-1	Unloading lubricating unit.	2-1
2-2	Trailer operating instructions.	2-2
2-3	Battery removal and installation.	2-3
2-4	Controls and instruments (sheet 1 of 4).	2-5
2-4	Controls and instruments (sheet 2 of 4).	2-6
2-4	Controls and instruments (sheet 3 of 4).	2-7
2-4	Controls and instruments (sheet 4 of 4).	2-8
2-5	Starting the engine.	2-9
2-6	Stopping the engine.	2-10
2-7	Transfer pump operation.	2-11
2-8	Preparing lubricant pumps for operation (sheet 1 of 3).	2-12
2-8	Preparing lubricant pumps for operation (sheet 2 of 3).	2-13
2-8	Preparing lubricant pumps for operation (sheet 1 of 3).	2-14
2-9	Dispensing general purpose grease.	2-16
2-10	Dispensing gear oil.	2-17
2-11	Dispensing engine oil.	2-18
2-12	Lower drawer and accessories.	2-19
2-13	Shutting down the, lubricating unit.	2-20
2-14	Alcohol dispenser service and operation.	2-21
2-15	Upper drawer and accessories.	2-23
2-16	Portable lubricator assembly.	2-25
3-1	Fuel filter service.	3-4
3-2	Generator drive belt adjustment.	3-5
3-3	Compressor drive belt adjustment.	3-6
3-4	Compressor air cleaner service.	3-7
3-5	Trailer air brake filter and reservoir service.	3-8
4-1	Enclosure assembly, disassembly and reassembly.	4-4
4-2	Tool box and accessory drawer, removal and installation.	4-5
4-3	Trouble light disassembly and reassembly.	4-6
4-4	Generator and voltage regulator removal and installation.	4-7
4-5	Starting motor removal and installation.	4-8
4-6	Oil pressure transmitter and oil pressure switches, removal and installation.	4-9
4-7	Cages, control panel and switches, removal and installation.	4-10
4-8	Trailer clearance light and lamps, removal and installation.	4-11
4-9	Trailer clearance lights, disassembly and reassembly.	4-12
4-10	Reflectors, blackout-stoplight, taillights, lamp and wiring harness, removal (sheet 1 of 2).	4-12
4-10	Reflectors, blackout-stoplight, taillights, lamp and wiring harness, removal (sheet 2 of 2).	4-13
4-11	Taillight and blackout-stoplight disassembly and reassembly.	4-14
4-12	Intervehicular receptacle, disassembly and reassembly.	4-15
4-13	Fuel tank, removal and installation.	4-16
4-14	Exhaust diverter valve, removal and installation.	4-17
4-15	Compressor drive pulley, removal and installation	4-19
4-16	Air compressor removal and installation.	4-20
4-17	Air receiver, lines and fittings, removal and installation.	4-21
4-18	Air regulator valve, removal and installation.	4-23
4-19	Air regulator, disassembly and reassembly.	4-24
4-20	Lubricant pump, removal and installation.	4-25
4-21	Lubricant tank cover, removal and installation.	4-26
4-22	Lubricant valve and meters, removal and installation.	4-27
4-23	Lubricant and air hoses, removal and installation.	4-29
4-24	Hose reel assembly, removal and installation.	4-31
4-25	Hose reel bank, removal and installation.	4-32

<i>Figure Number</i>	<i>Title</i>	<i>Page</i>
4-26	Alcohol dispenser, removal and installation.	4-33
4-27	Alcohol dispenser disassemble) and reassembly.	4-34
4-28	Engine and clutch, removal and installation.	4-36
4-29	Wheel and tire, removal and installation.	4-38
4-30	Wheel hub and brake drum, removal, disassembly. reassembly and installation.	4-40
4-31	Service brake adjustment and bleeding.	4-41
4-32	Wheel cylinder and brake shoe, removal and installation (sheet 1 of 2).	4-43
4-32	Wheel cylinder and brake shoe, removal and installation (sheet 2 of 2).	4-44
4-33	Hydraulic master cylinder, brake chamber and relay valve, removal and installation	4-45
4-34	Air brake chamber, disassembly and reassembly.	4-46
4-35	Air receiver and air filter, removal and installation.	4-47
4-36	Landing gear and lunette, removal and installation.	4-48
4-37	Landing gear disassembly and reassembly.	4-49
4-38	Trailer suspension system and wheel chocks, removal and installation (sheet 1 of 2).	4-50
4-38	Trailer suspension system and wheel chocks. removal and installation (sheet 2 of 2).	4-51
4-39	Fender removal and installation.	4-52
4-40	Safety chain, removal and installation.	4-53

CHAPTER 1

INTRODUCTION

Section I. GENERAL

1-1. Scope

u. This manual is published for the use of the personnel to whom the Henry Spen and Company lubricating and servicing unit Model 901765-1 is issued. It provides information on the operation and organizational maintenance of the equipment. Also included are descriptions of main units and their functions in relation to other components.

b. Appendix A contains a list of publications applicable to this manual. Appendix B contains the maintenance allocation chart. Appendix C contains a list of basic issue items authorized the operator of the equipment.

c. Numbers in parentheses on illustrations indicate quantity. Numbers preceding nomenclature callouts on illustrations indicate the preferred maintenance sequence.

d. Report of errors, omissions, and recommendations for improving this publication by the individual user is encouraged. Reports should be submitted on DA Form 2028, Recommended Changes to Publications, and forwarded direct to Commanding General, U. S. Army Mobility Equipment Command, ATTN:

AMSME-MPP, 4300 Goodfellow Boulevard, St. Louis, Mo. 63120.

e. Refer to TM 750-244-3 (Procedures for Destruction of Equipment to Prevent Enemy Use), for information and instructions on destruction of equipment to prevent enemy use.

1-2. Administrative Storage

Refer to TM 740-90-1 (Administrative Storage of Equipment) for information and instructions pertaining to organizational administrative storage.

1-3. Record and Report Forms

a. DA Form 1397 (Processing and Reprocessing Record for Shipment, Storage, and Issue of Vehicles and Spare Engines).

b. DA forms and records used for equipment maintenance will be only those prescribed by TM 38-750, Army Equipment Record Procedures.

NOTE

Applicable forms, excluding Standard Form 46 (United States Government Motor Vehicles Operator's Identification Card) which is carried by the operator, will be kept in canvas bag mounted on the equipment.

Section II. DESCRIPTION AND DATA

1-4. Description

a. The Henry Spen Model 901765-1 lubricating and servicing unit (fig. 1-1 and 1-2) is a trailer mounted, self contained, gasoline-powered unit equipped for heavy-duty servicing. Compressed air forces lubricant and motor oil from storage tanks through reel-mounted hoses to the unit to be lubricated. Engine oil, lubricant and grease are stored in three steel con-

tainers. In freezing temperatures, exhaust gases, ducted into a heat reservoir beneath the containers, warm the lubricants so they flow easily. The air-alcohol dispenser prevents condensation in the air lines from freezing. Each lubricant container has an air powered pump. The air pressure and speed of each pump is controlled by separate air pressure regulator and a pressure gage is attached to each regulator to register the air pressure.

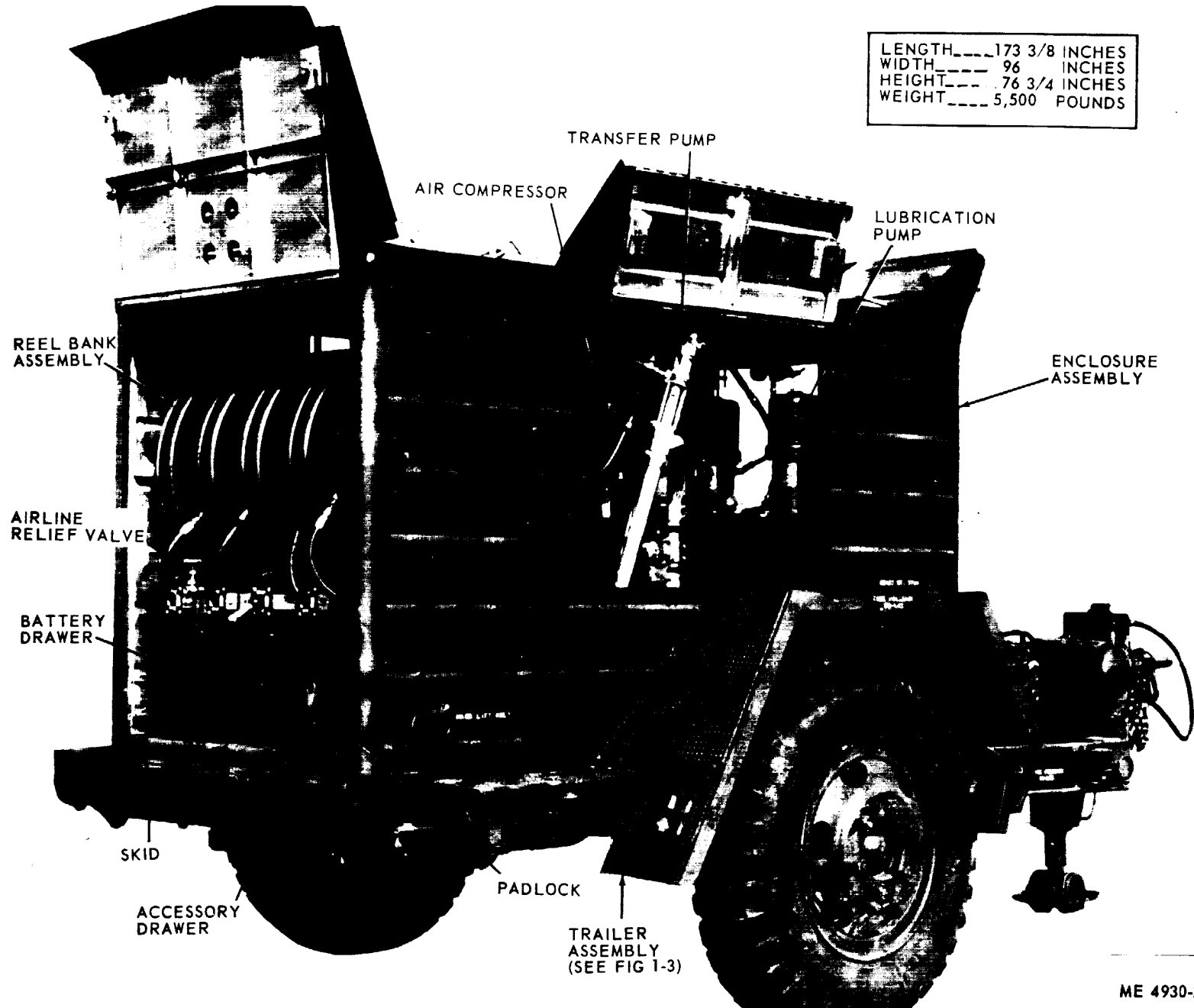
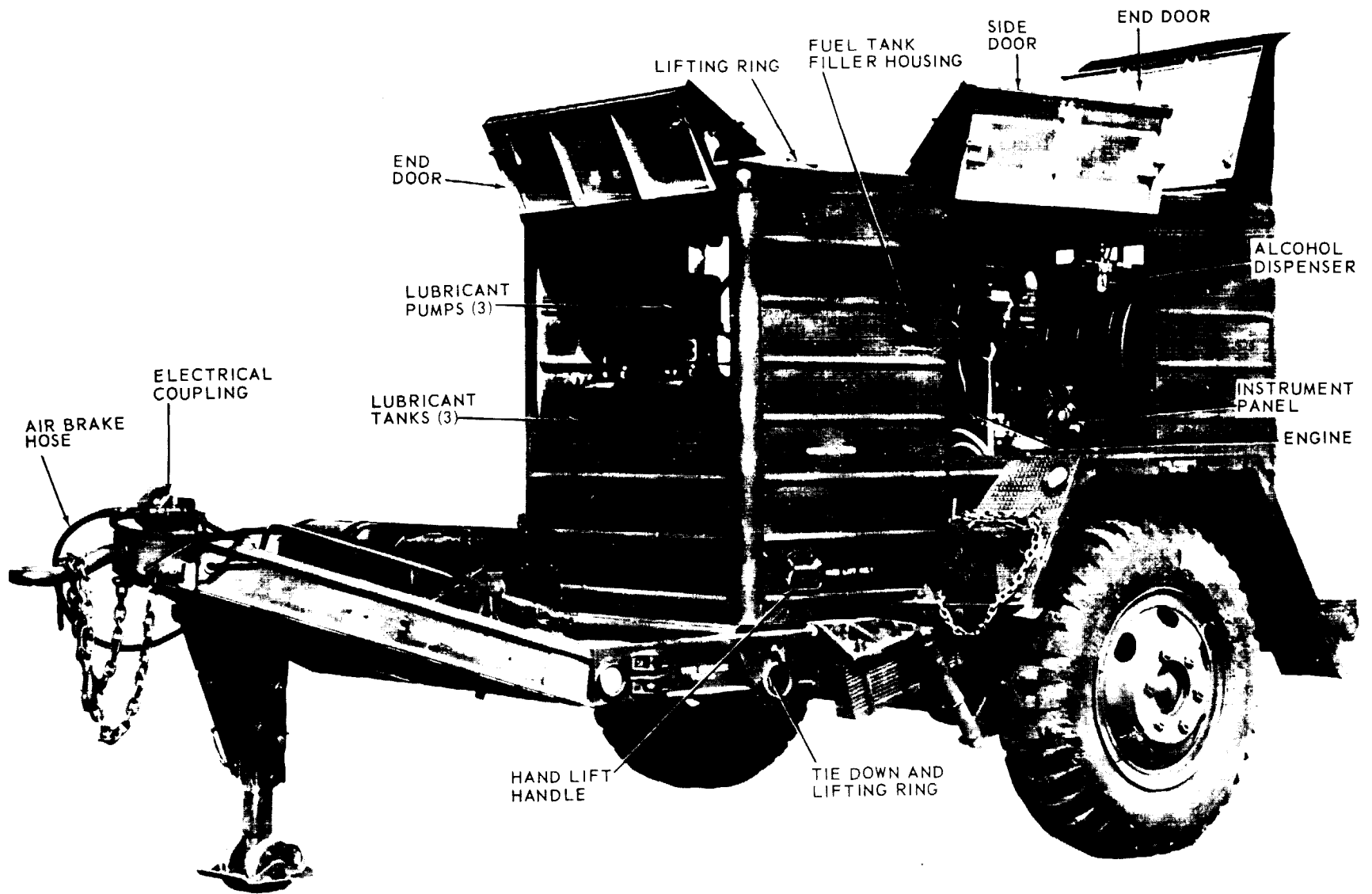

Figure 1-1. Lubricating unit, right rear, 3/4 view.



ME 4930-207-12/1-2

Figure 1-2. Lubricating unit, left front, 3/4 view.

b. A four cylinder, four cycle, air-cooled engine powers the air compressor. Two 12 volt batteries connected in a series, supply power to the electric starting motor. The engine can also be started with a rope if the starter fails.

c. The piston type air compressor delivers 23 cfm (cubic feet per minute) at 175 psi (pounds per square inch). An automatic pressure control stops the compressor from pumping when the air receiver pressure reaches 175 psi, and starts the compressor pumping when pressure drops to 150 psi.

d. A hose reel bank, consisting of five hand-operated reels, is mounted at the rear of the lubricator, together with the necessary fittings, control valves

and meters. Four hoses deliver lubricant, and one hose delivers compressed air. Accessory drawers located directly below the reel bank contain hand guns, pneumatic guns, oilers, adapters and grease fittings. An aluminum housing protects the unit under all climatic conditions. A door on each side of the housing gives easy access to all parts, controls, and the lubricant storage compartments.

e. The lubricating and servicing unit is mounted on a two wheel, drop axle, 2½ ton trailer (fig. 1-3 and 1-4). Equipped with hydraulic brakes, a retractable landing gear is installed on the trailer tongue to provide support for the unit when it is not connected to a mover.

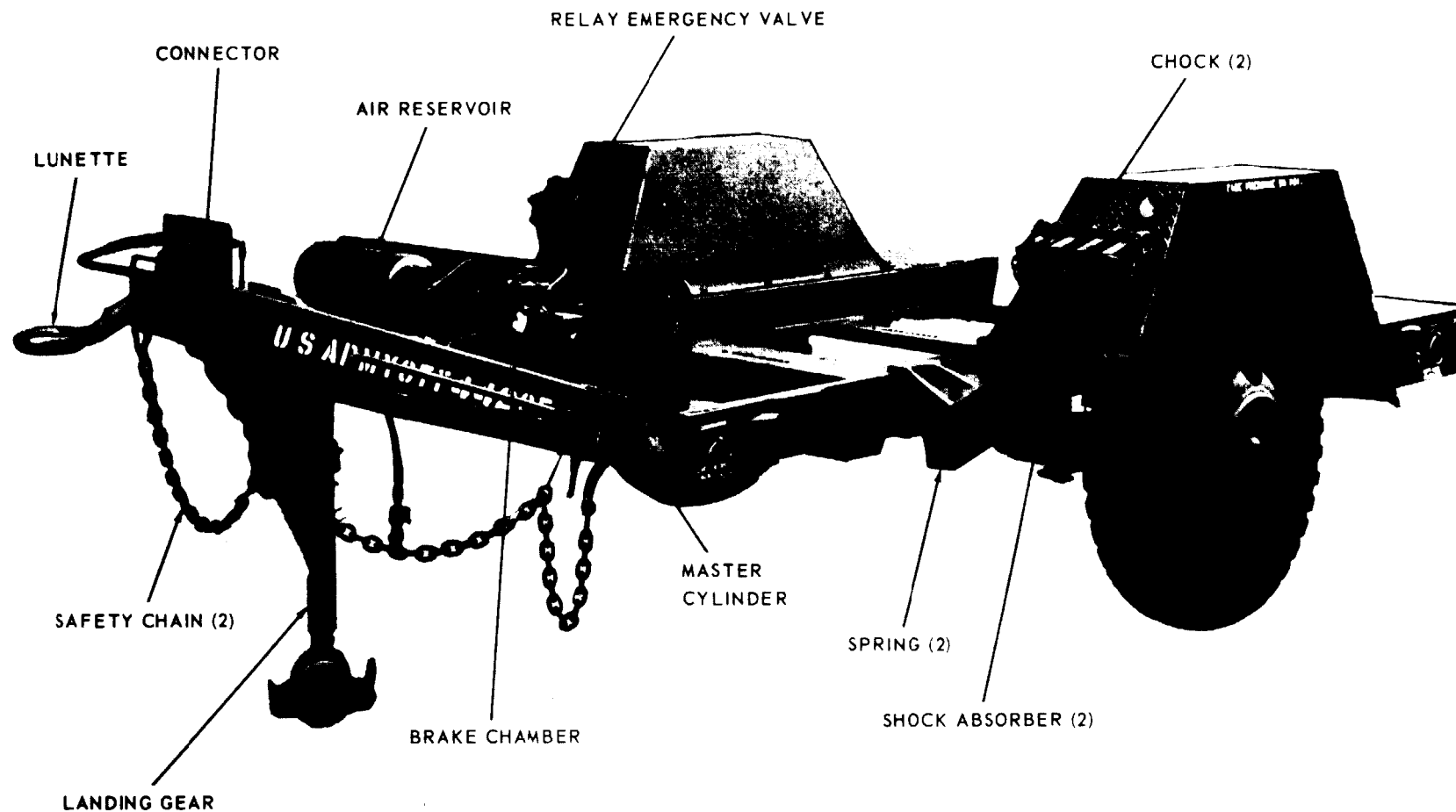

SHIPPING DIMENSIONS		
LENGTH	175	INCHES
WIDTH	96	INCHES
HEIGHT	50	INCHES
WEIGHT	2960	POUNDS

ME 4930-207-12/1-3

Figure 1-3. Trailer assembly, left front, three-quarter view.

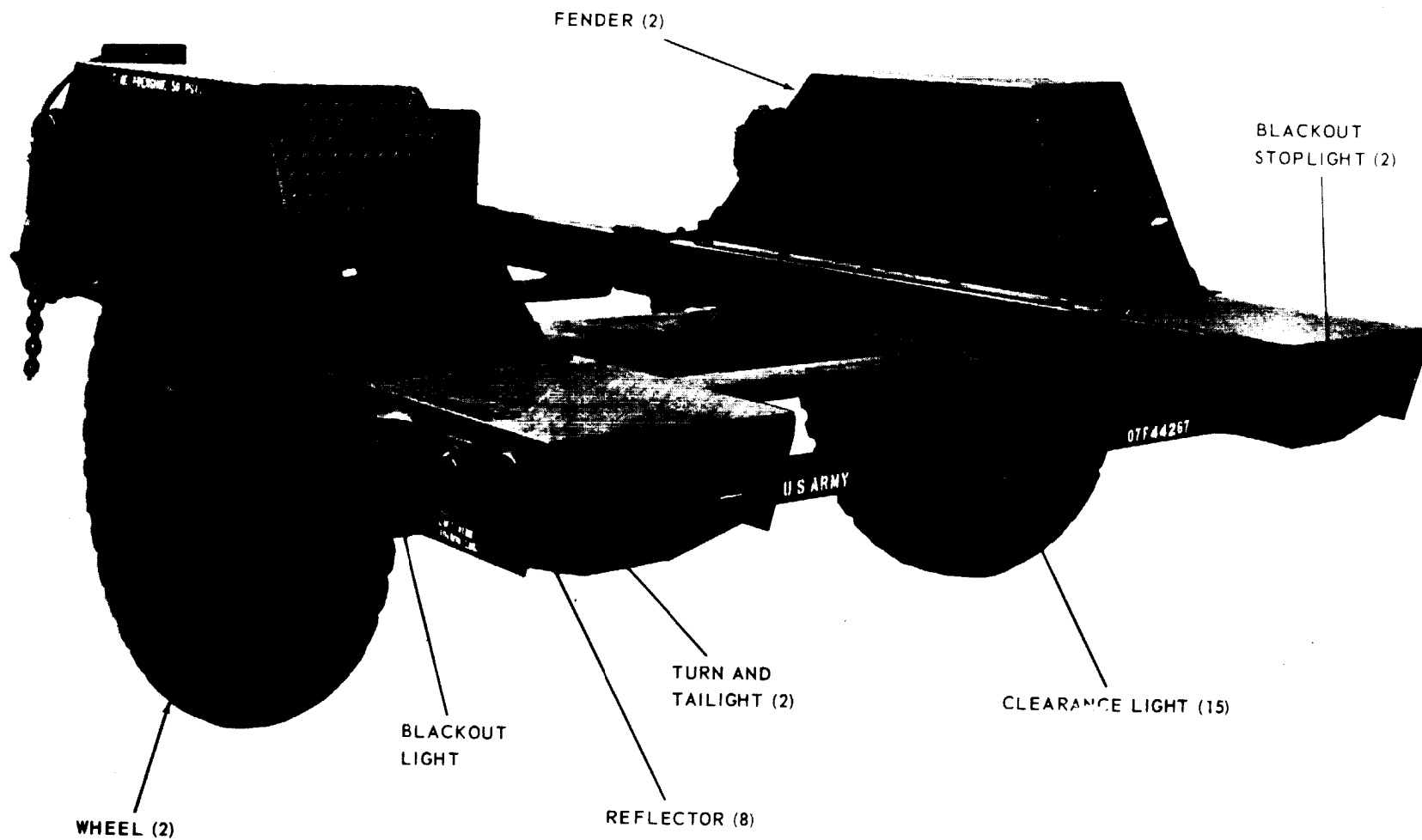

ME 4930-207-12/1-4

Figure 1-4. Trailer assembly left rear, three-quarter view.

1-5. Identification and Tabulated Data

a. *Identification.* The lubricating and servicing unit has five major data and instruction plates. The information contained on these plates is listed below.

(1) *Lubricator Corp of Engineers data plate.* Located on the left side of the unit enclosure. It gives the description, serial number, manufacturer, model and dimensions.

(2) *Trailer Corps of Engineers plate.* Located on the bulkhead at the front of the trailer. It gives the manufacturer, model, dimensions and capacity.

(3) *Engine data plate.* Located on the top of the engine block. It specifies the make, model, type, number of cylinders and piston displacement.

(4) *Compressor data plate.* Located on the compressor body. It gives the manufacturer, model and serial number.

(5) *Transportation data plate.* Located on the enclosure next to the corps of engineers plate. It gives the center of gravity, axle load and pintle load in pounds.

b. Tabulated Data.

(1) End item.

Manufacturer	Henry Spen and Co.
Model	90176.5-1

(2) Engine.

NOTE

Military Standard Engine Refer to TM 5-2805-203-1.t for engine and accessory tabulated data, except for starter and generator listed below.

(3) Generator.

Manufacturer	Electric Autolite Corp.
Model	GKP 4001
Volts	24

(4) Starting motor.

Manufacturer	Delco Remy
Model	1113516
Volts	24

(5) Air compressor.

Manufacturer	Saylor-Beall Manufacturing Co.
Model	705
Type	2 cylinder, 2 stage, vertical
Type drive	Belt
Displacement	23.0 cfm
Operating pressure	150-175 psi

(6) Transfer pump.

Manufacturer	Stewart-Warner
Model	330783
Operating pressure	75-150 psi

(7) High pressure lubricant pump.

Manufacturer	Stewart Warner
Model	G330769
Ratio	40 to 1

(8) Low pressure lubricant pump,

Manufacturer	Stewart Warner
Model	G330768
Ratio	12 to 1

(9) Type of lubricants required.

High pressure pump	General purpose grease
Low pressure pump	Engine and gear oil

(10) Batteries.

Voltage	12
Type	Negative ground
Number used	2

(11) Alcohol dispenser.

Manufacturer	Norgren, C. A. Co.
Model	10-002-124

(12) Trailer.

Manufacturer	Henry Spen and CO.
Model	906936-1
Type	Military Standard
Tire size	900 x 20
Tire pressure:	
Normal	50 lbs.
Sandy or rough terrain	40 lbs.
Contract number	DAAKO1-67-C-1259
Pay load	5,000 lbs.
Cube	458cu. in.

(13) Capacities.

Hydraulic brake system	5/16 qt. (quart)
Engine crankcase	21/8 qt.
Engine oil filter	1 pt. (pint)
Compressor crankcase	2 qt.
Fuel tank	10 gal. (gallons)
Alcohol dispenser	¼ qt.
Lubricant storage containers:	
Lubricating grease	175 lb. (pounds)
Lubricating gear oil	27 gal.
Lubricating oil	27 gal.

(14) Dimensions.

Length (a) Trailer.

	172 in. (inches)
Width	96 in.
Height	48 in.
Weight	2,730 lbs.

(b) Lubicator and trailer.

Height	76 ¾ in.
Length	173 3/8 in.
Width	96 in.
Shipping weight	(5,500 lbs.
Shipping cube	758 cu. ft. (cubic feet)
Center of gravity	25 in. above-ground level and 114½ in. from lunette end

(15) *Trailer wiring Diagram.* Refer to figure 1-5 for the trailer schematic wiring diagram.

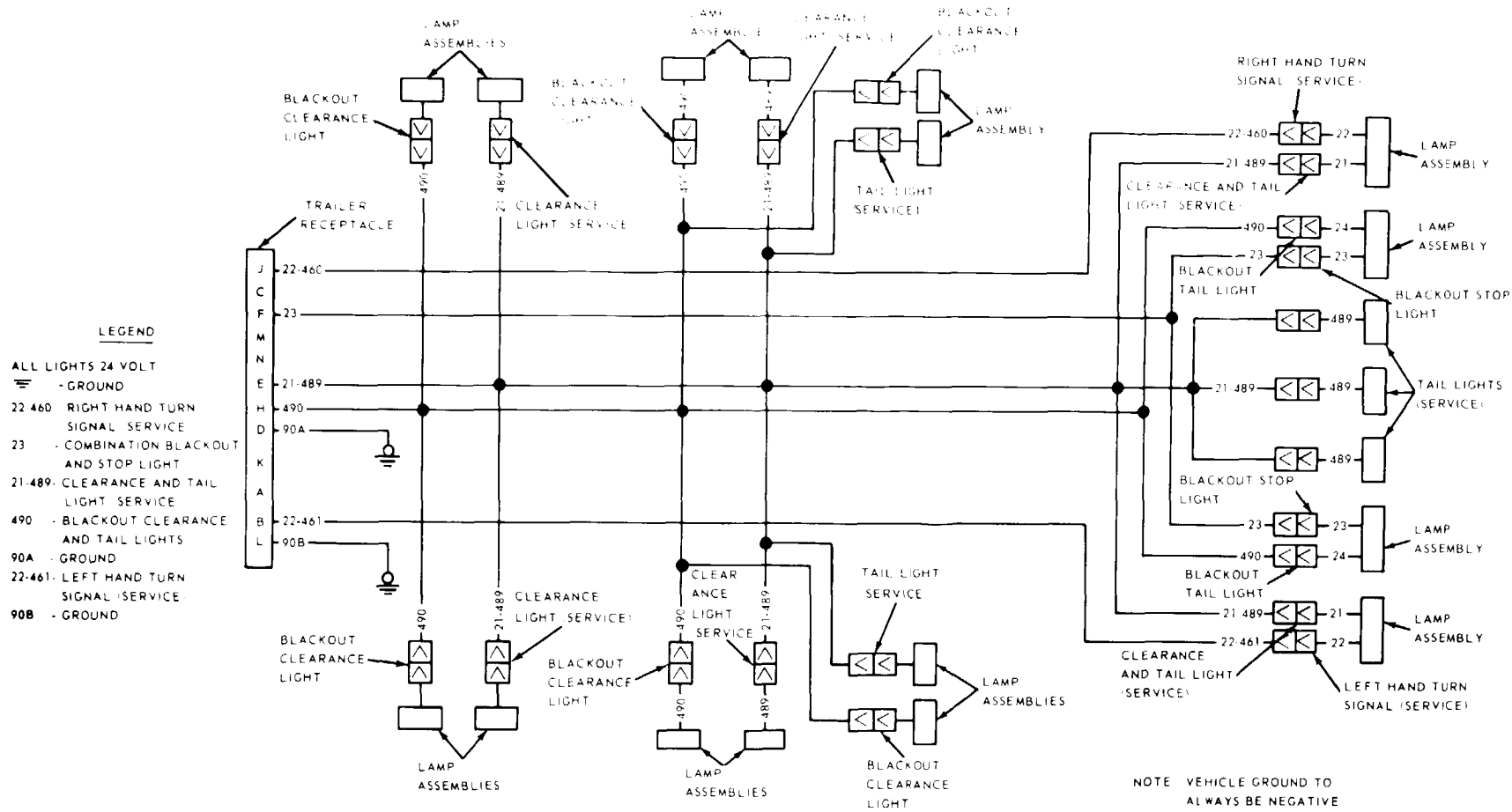
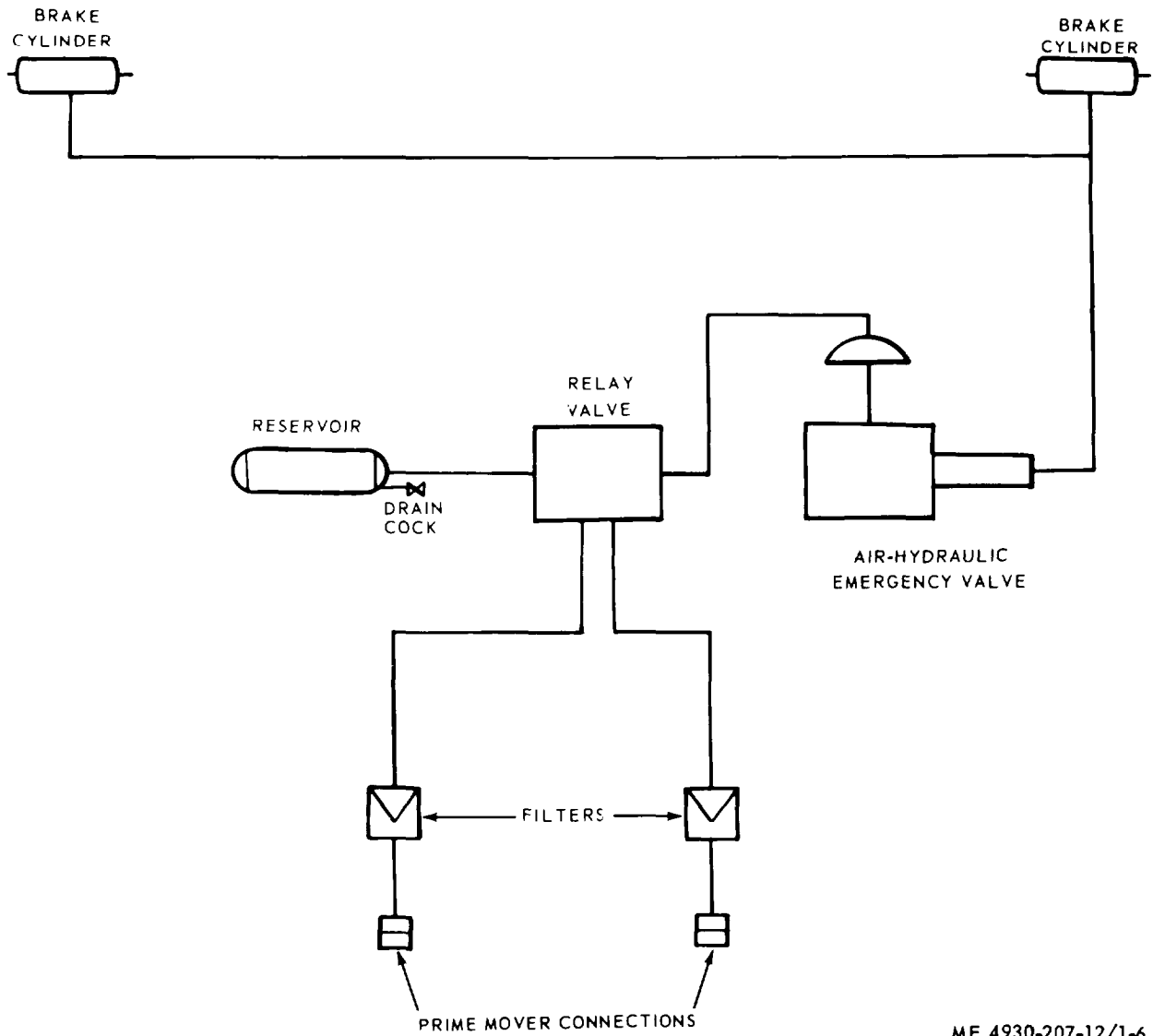

Figure 1-5. Trailer schematic wiring diagram.

(16) *Hydraulic brake schematic diagram.* Refer to figure 1-6 for trailer hydraulic brake system schematic diagram.



ME 4930-207-12/1-6

Figure 1-6. Hydraulic brake system schematic diagram.

(17) Lubricator wiring diagram. Refer to figure 1-7 for the lubricator schematic wiring diagram.

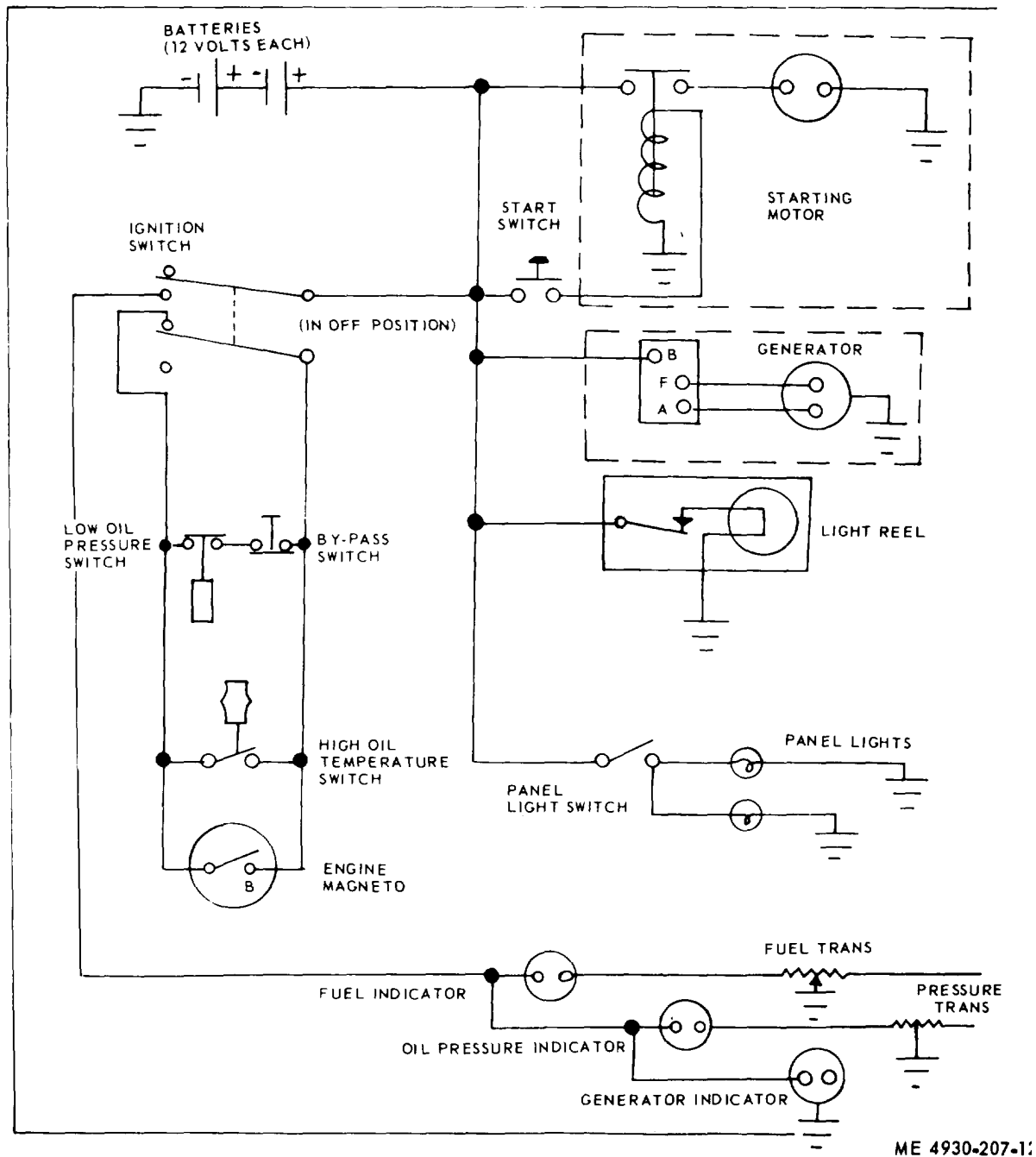

Figure 1-7. Lubricator schematic wiring diagram.

1-6. Difference in Models

This manual covers only the Henry Spen and Co.

lubricating and servicing unit. No known unit differences exist for the model covered by this manual.

CHAPTER 2
INSTALLATION AND OPERATING INSTRUCTIONS

Section I. SERVICE UPON RECEIPT OF EQUIPMENT

2-1. Unloading Equipment

a. General. The lubricating and servicing unit may be unloaded from the carrier by towing with a prime mover or by the use of a suitable lifting device and slings with a capacity of at least 6,000 pounds.

WARNING

Do not use a lifting device with a capacity of less than 6,000 pounds. Do not allow the

lubricator to sway while being suspended. Failure to observe this warning can result in damage to the equipment and injury to personnel.

b. Ramp Unloading.

(1) Remove the tie down cables and blocking (fig. 2-1) which secure the equipment to the carrier bed.

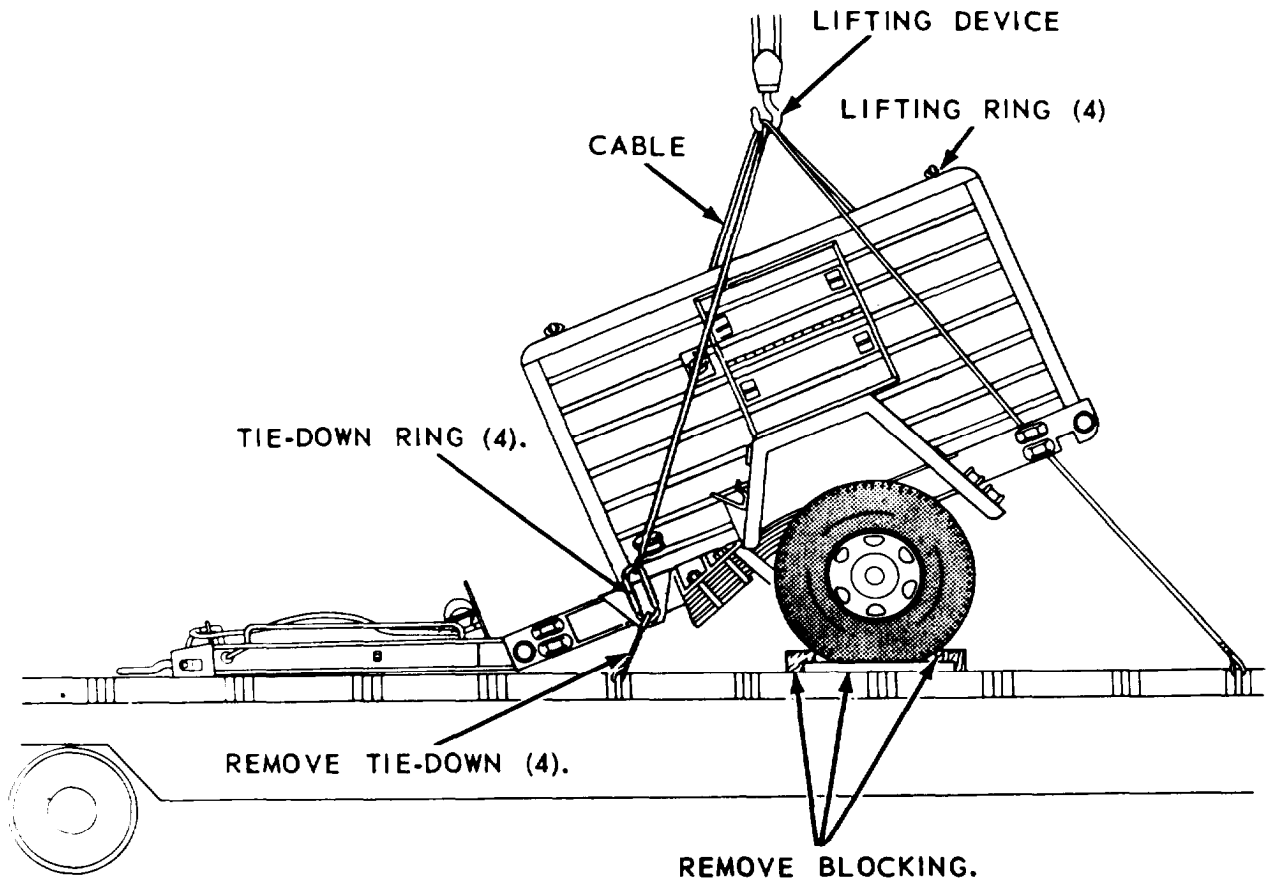

ME 4930-207-12/2-1

(2) Construct a suitable ramp at the end of the carrier bed.

(3) Aline and secure the lubricating unit to the towing vehicle, and connect the trailer brake coup-

lings, electrical connections and safety chain as illustrated in figure 2-2. Block wheels of carrier so it will remain stationary and tow the lubricator from the carrier.

NOTE: MAKE SURE THE AIR RESERVOIR DRAIN VALVE IS CLOSED.

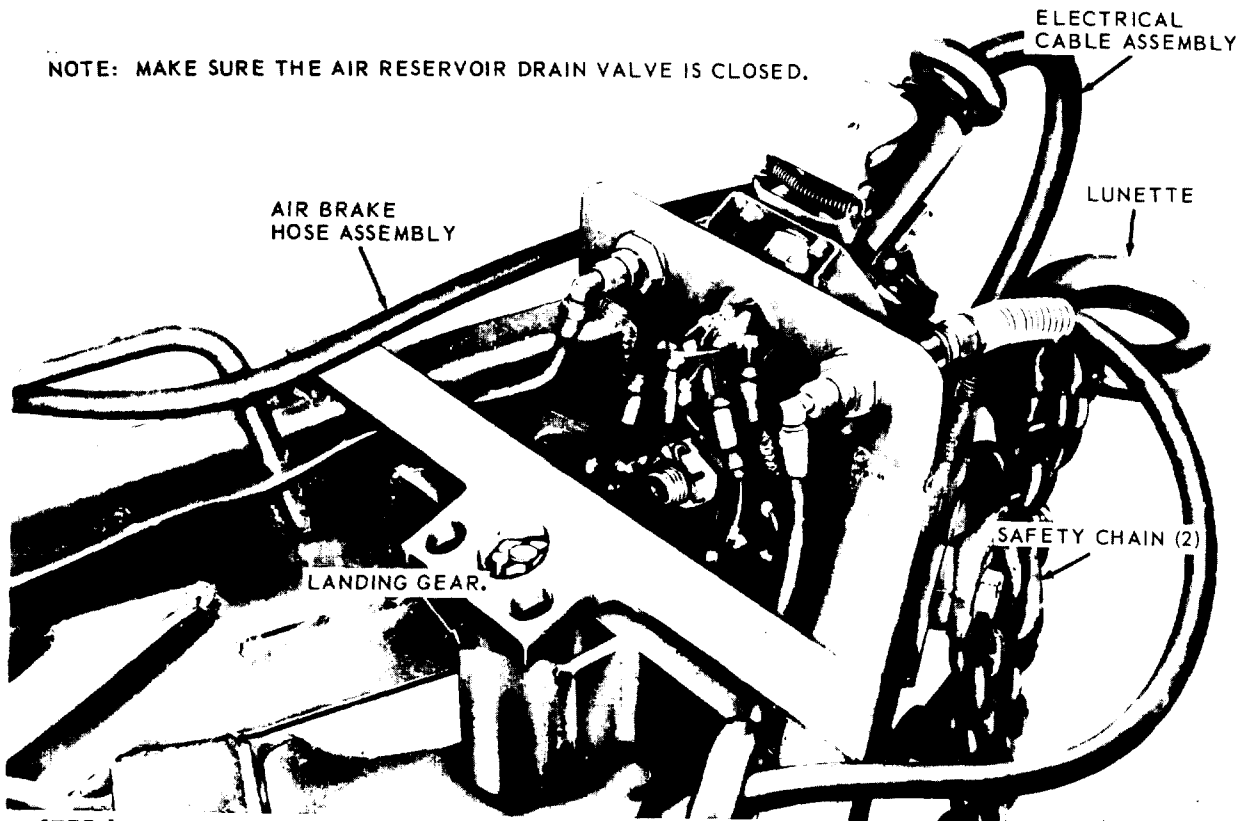

- STEP 1. CONNECT THE LUNETTE TO THE PINTLE OF THE PRIME MOVER.
- STEP 2. CONNECT THE AIR BRAKE HOSE ASSEMBLY AND ELECTRICAL CABLE ASSEMBLY TO THE PRIME MOVER.
- STEP 3. CONNECT THE SAFETY CHAINS TO THE PRIME MOVER.
- STEP 4. RETRACT THE LANDING GEAR AND SECURE IN POSITION AND TOW THE TRAILER.

ME 4930-207-12/2-2

Figure 2-2. Trailer operating instructions.

c. Lifting the Equipment.

(1) Remove the tie down cables and blocking (fig. 2-1) which secure the equipment to the carrier bed

(2) Attach a suitable lifting device with a capacity of at least 6,000 lbs. and remove the lubricating unit from the carrier bed as illustrated in figure 2-1.

2-2. Inspecting and Servicing Equipment

a. Refer to TM 5-2805-203-14 and perform the engine daily preventive maintenance services.

b. Perform the lubricator and trailer preventive maintenance services (para 3-7).

c. Make a complete visual inspection of the lubricating and servicing unit for loss, damage or pilferage of components.

d. Inspect the lubricator for damaged enclosure and doors. Inspect all components for proper and secure mounting.

e. Make sure all equipment shipped with the unit is undamaged and in a serviceable condition.

f. Remove caps from battery cells and fill with

electrolyte to a level $\frac{1}{4}$ in. below filler holes. Refer to TM 9-6140 -200-15 for complete servicing of wet batteries.

WARNING

When servicing batteries, do not smoke or use an open flame in the vicinity. Batteries generate hydrogen, a highly explosive gas.

g. Lubricate the unit in accordance with LO 5-4930-207-12.

2-3. Installation of Separately Packed Components

a. The batteries for the unit may be shipped dry-charged. The electrolyte for filling the batteries is shipped in separate containers. Fill the batteries with electrolyte until the level is $\frac{1}{4}$ in. below the filler holes. Recharge batteries after filling with electrolyte when shipped dry charge.

b. When batteries are filled, remove thumb nut (1, fig. 2-3), washers (2 and 3) and clamps (4) and install the batteries (8) in the battery drawer (11).

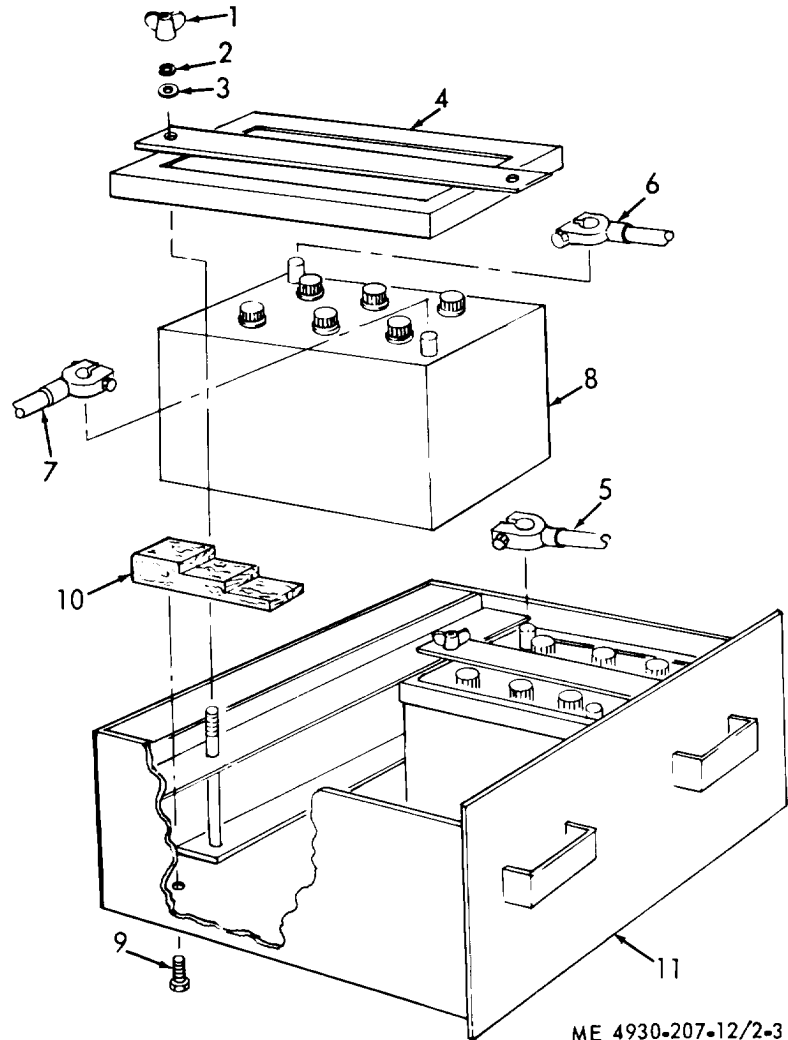

- 1 Thumb nut
- 2 Lockwasher
- 3 Flatwasher
- 4 Battery hold-down clamp
- 5 Jumper cable
- 6 Positive cable
- 7 Negative ground cable
- 8 Battery
- 9 Wood screw
- 10 Battery spacer
- 11 Battery drawer

c. Install cables (5, 6 and 7) and reinstall the clamps. Make sure the negative ground cable (7) is installed on the negative battery post.

WARNING

**Clean any spilled electrolyte with water.
Keep electrolyte off skin to prevent personal injury.**

2-4. Installation or Setting Up Instructions

a. *General.* The lubrication and servicing unit is a self-contained unit and requires no special mounting base. Locate the unit where it will be level at all times and will receive a supply of clean, dry air. Air filled with dust will clog the air cleaners. If the unit is placed in a confined area, and air circulation is restricted, it could heat up and affect the operation. Locate the equipment so that the hose reels and lubricant pumps are accessible. Block wheels so the unit will not roll and lower the trailer landing gear.

WARNING

Make sure the landing gear is in the down position and secured before disconnecting the trailer from the towing vehicle as serious injury to personnel may result.

b. *Batteries.*

(1) Service the batteries as outlined in paragraph 2-2.

(2) Inspect the battery terminal as follows:

(a) Remove thumb nuts (1, fig. 2-3), washers (2 and 3) and holddown clamp (4).

(b) Remove terminal ends of cables (5, 6, and 7); inspect cables and terminals for loose or corroded condition. Remove corrosion and coat terminals with grease.

(c) Install terminal ends of cables (5, 6 and 7) on battery terminals and tighten nuts to friction fit on battery post.

(d) Tighten locknut and push handle down until it is parallel with clamp.

(e) Install holddown clamp (4, fig. 2-3) on batteries (8) and secure with washers (2 and 3) and thumb nut (1).

c. *Inclosure Doors.* Open inclosure doors (fig. 1-2) for adequate air circulation.

WARNING

Do not operate the lubricating and servicing unit in an enclosed area unless the exhaust gases are piped to the outside. Inhalation of exhaust fumes will result in serious illness or death.

d. *Compressor.* Remove the protection wrapper from the compressor air cleaner.

Section II. MOVEMENT TO A NEW WORKSITE

2-5. Dismantling for Movement

a. Release all air from the air receiver by opening the air line relief valve (fig. 1-1).

b. Disconnect battery cables (5, 6, and 7, fig. 2-3) from batteries (8).

c. Lock the hose reels by applying the reel brake and properly stow all accessories and tools. Close lubricant containers and the inclosure doors.

d. The lubricating unit is self-contained and requires no disassembly for movement.

e. Refer to paragraph 1-4 and inflate the tires to the proper pressure.

f. Refer to figure 2-2 and connect the trailer to the prime mover and retract the landing gear.

g. Remove the two wheel chocks (fig. 1-3) and stow them in fender mounting bracket.

2-6. Reinstallation After Movement

Refer to paragraph 2-4 for reinstallation instructions after movement.

Section III. CONTROLS AND INSTRUMENTS

2-7. General

This section describes, locates, illustrates and furnishes operator, crew, or organizational maintenance personnel sufficient information about various controls and instruments for proper operating of the lubricating and servicing unit.

2-8. Controls and Instruments

The purpose of the controls and instruments and the normal maximum reading are illustrated in figure 2-4.

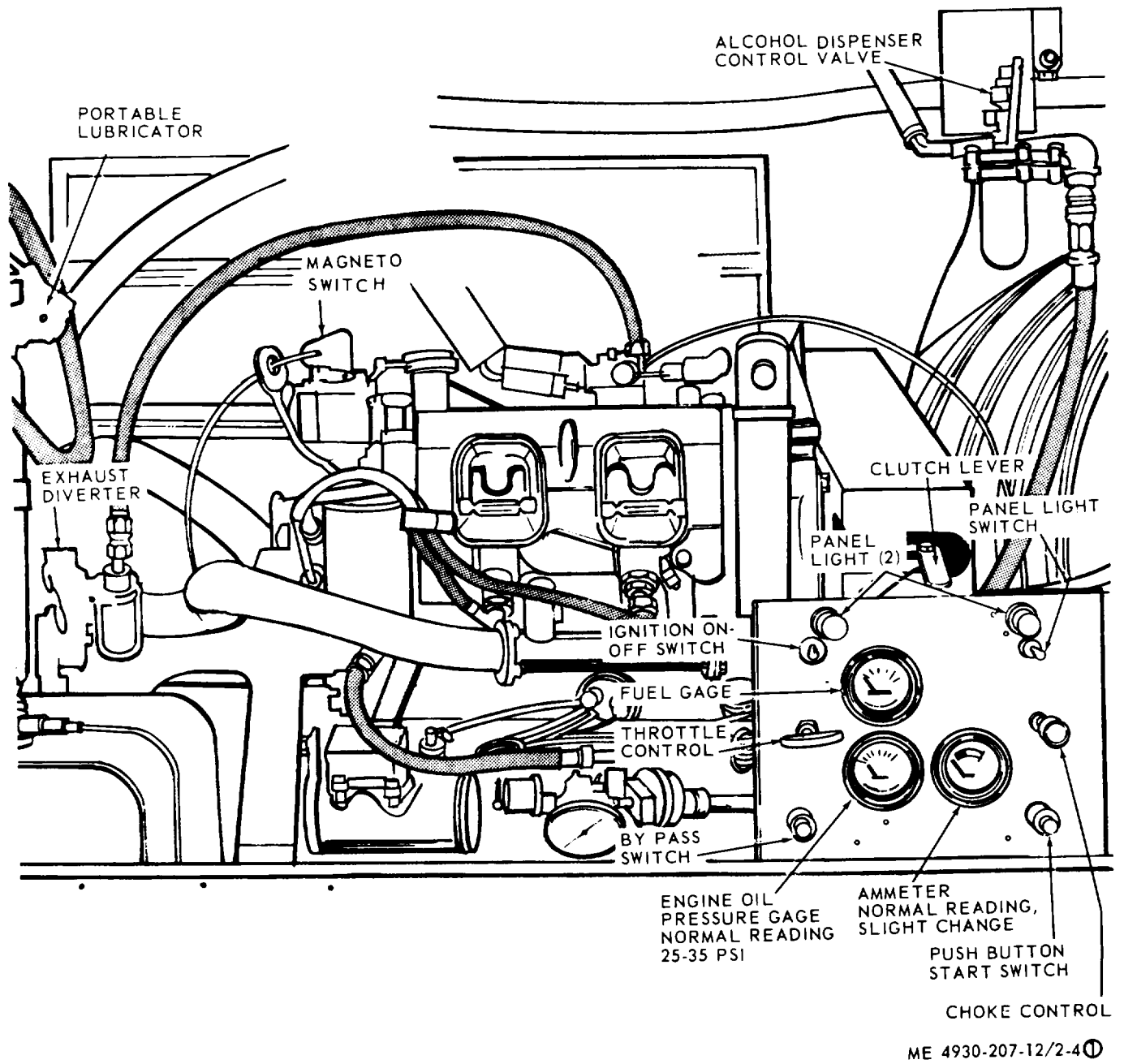

Figure 2-4. Control and instruments (sheet 1 of 4).

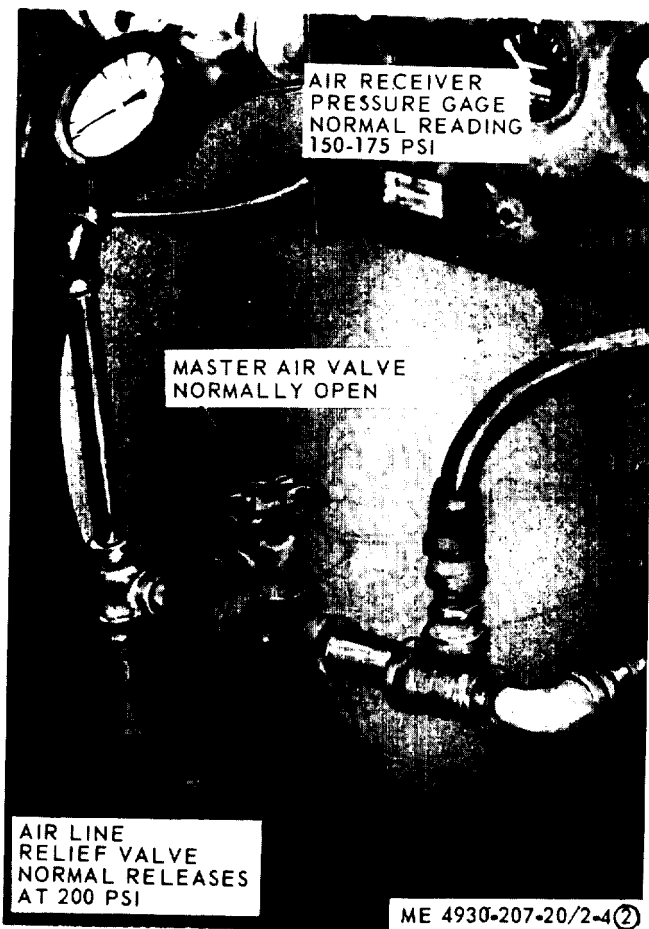

Figure 2-4. Controls and instrument is (sheet 2 of 4)

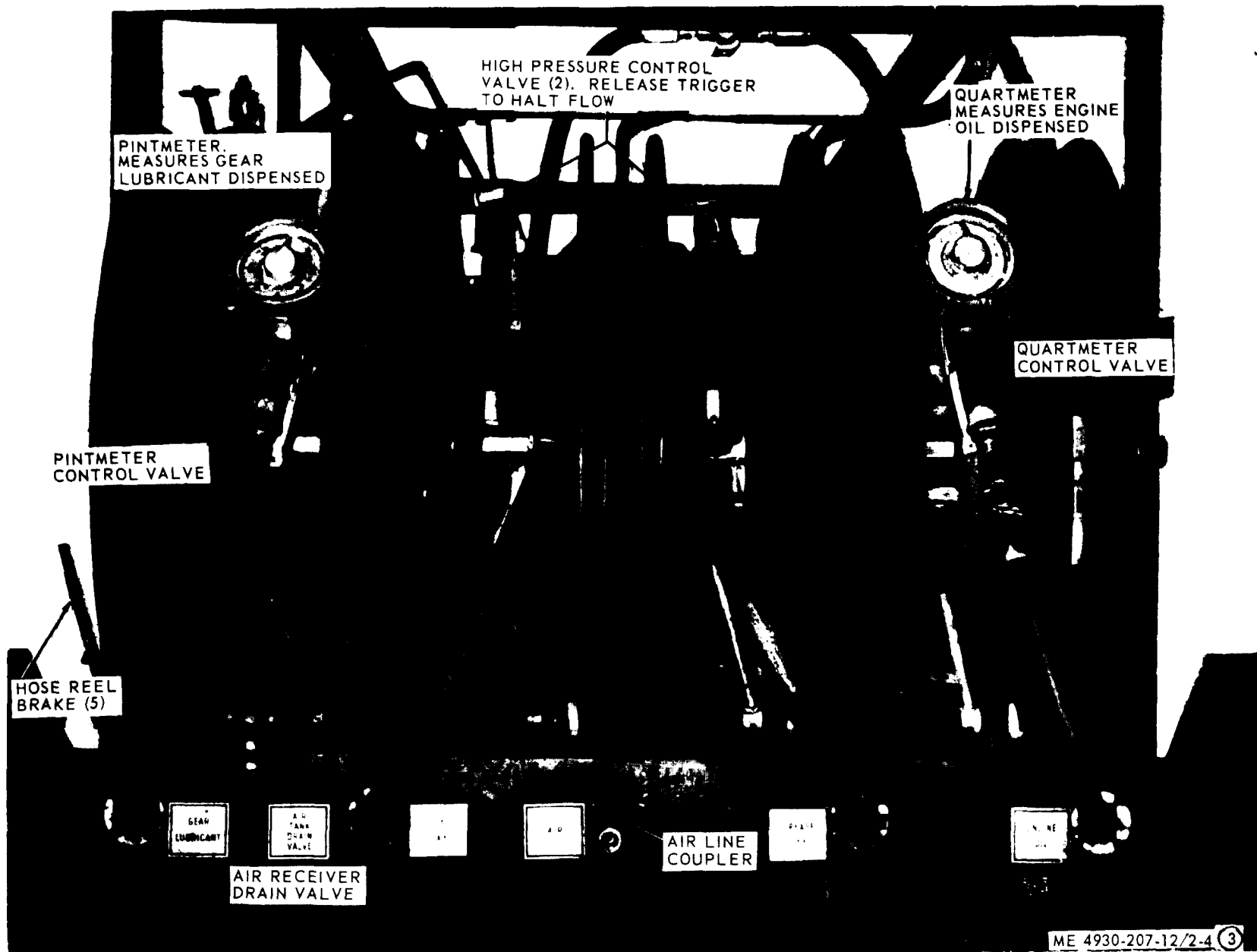

Figure 2-4. Controls and instruments (sheet 3 of 4).

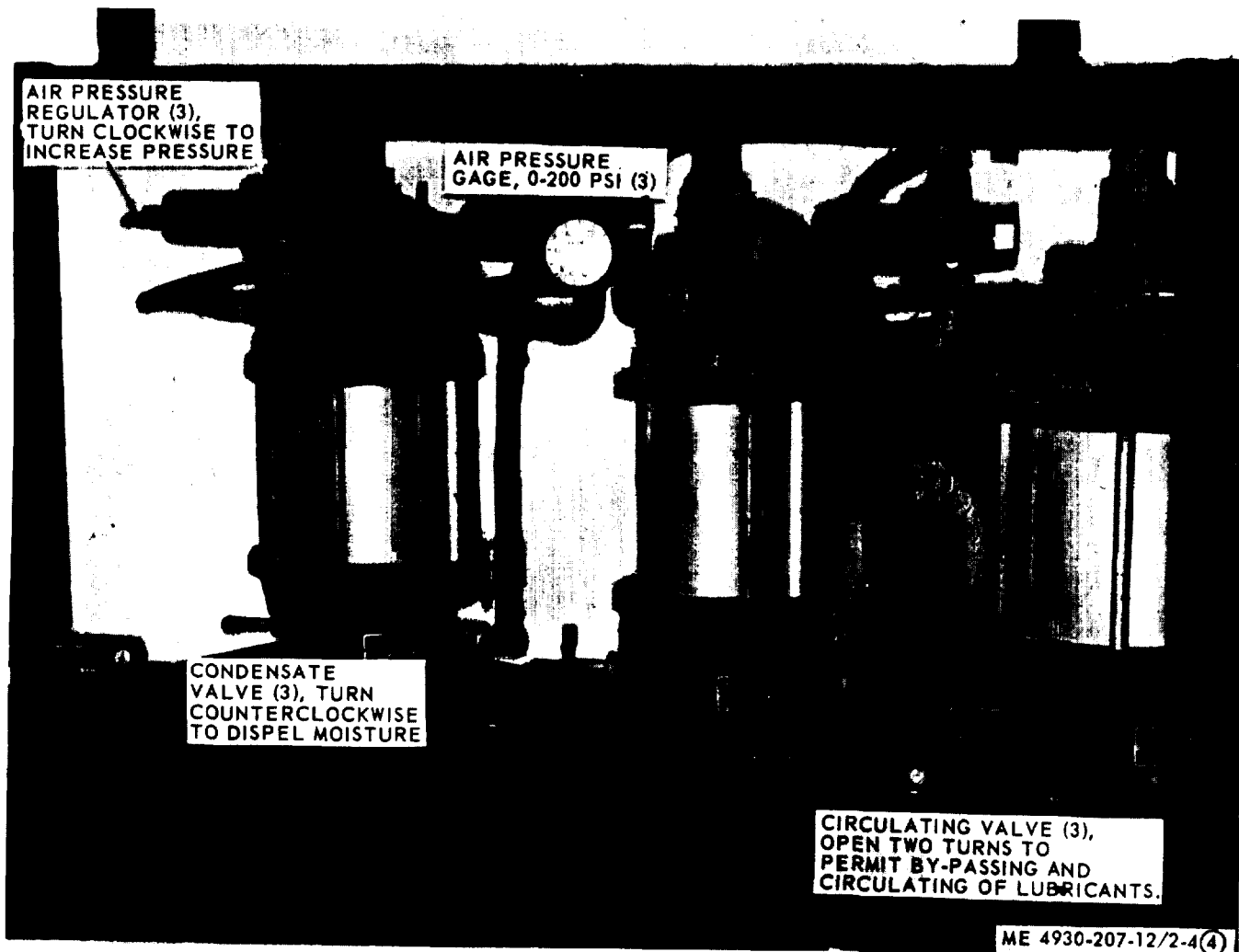

Figure 2-4. controls and instruments (sheet 4 of 4).

Section IV. OPERATION UNDER USUAL CONDITIONS

2-9. General

u. The instructions in this section are published for the information and guidance of personnel responsible for the operation of the lubricating and servicing unit.

b. The operator must know how to perform every operation of which the lubricating and servicing unit is capable. This section gives instructions on starting and stopping and lubricating and servicing unit, operation of the lubricating and servicing unit, and

on coordinating the basic motions to perform the specific tasks for which the equipment is designed. Since nearly every job presents a different problem, the operator may have to vary given procedures to fit the individual job.

2-10. Starting Engine

a. *Preparation for Starting.* Perform the before operation preventive maintenance services (para 3-7).

b. *Electric Starting of Engine.* Start the engine as illustrated in figure 2-5.

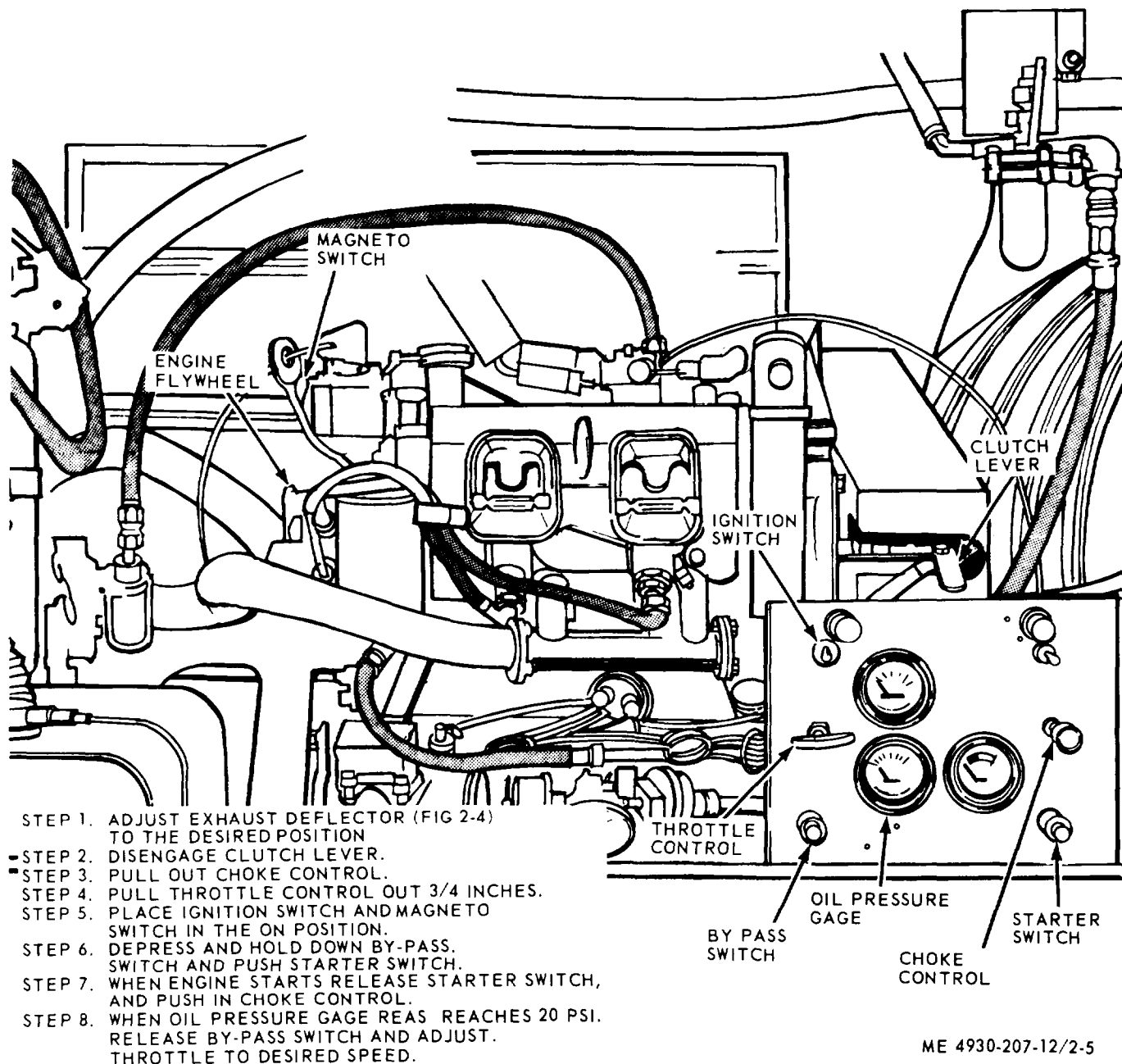

Figure 2-5. Starting the engine.

CAUTION

Do not crank the engine more than 30 seconds continuously without allowing a two minute cooling period for the starter.

CAUTION

Do not operate the engine if oil pressure gage fails to register or if the ammeter does not show a tendency to charge.

c. Manual Starting of Engine.

- (1) Perform steps 1 through 5 (fig. 2-5).
- (2) Wind the starting rope in a clockwise direction around the engine flywheel leaving about 6 inches free at handle end.

(3) Have a second person depress and hold down the by pass switch (fig. 2-5).

(4) Give a fast strong steady pull the full length of the rope. If the engine does not start at the first attempt, increase choking and crank again.

(5) After the engine starts, gradually push the choke control in until the engine runs smoothly. Increase throttle if necessary, and release by-pass switch.

2-11. Stopping the Engine

a. *Normal Stopping.* Stop the engine as illustrated in figure 2-6.

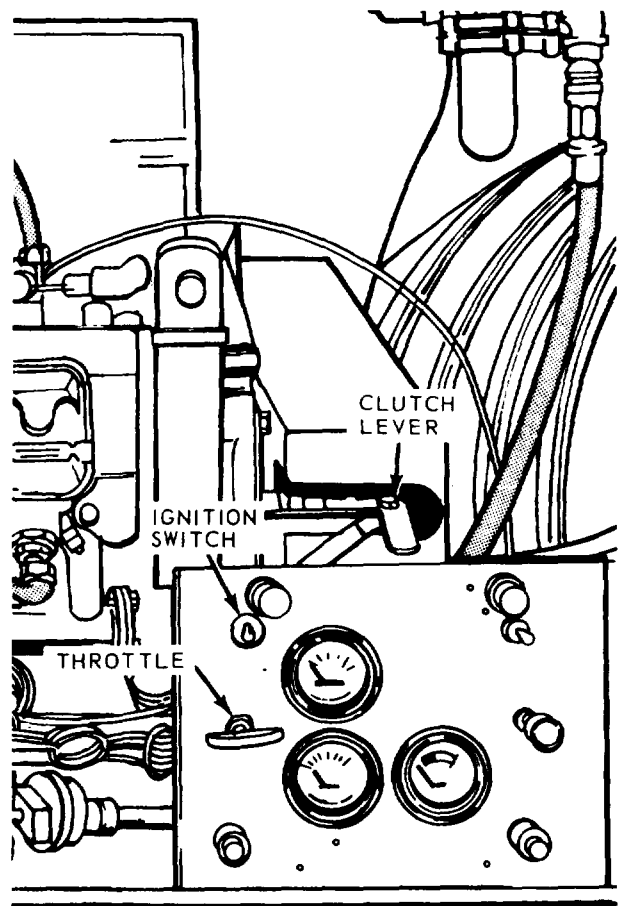
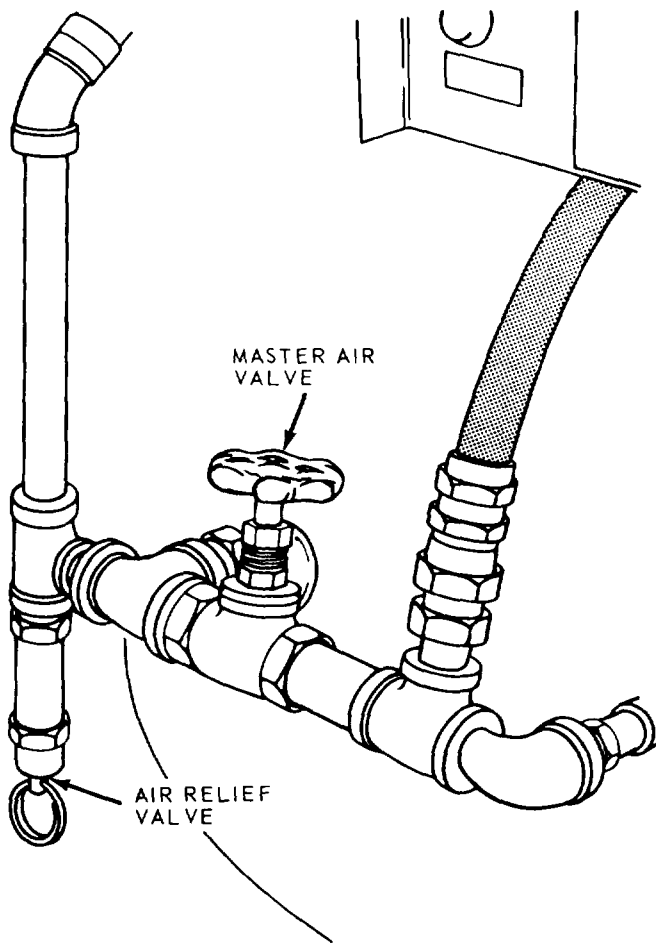

- STEP 1. DISENGAGE CLUTCH LEVER
- STEP 2. CLOSE THROTTLE
- STEP 3. CLOSE MASTER AIR VALVE
- STEP 4. RELEASE AIR PRESSURE BY PULLING RING ON AIR RELIEF VALVE
- STEP 5. OPEN AIR TANK DRAIN VALVE (FIG 2-4)
- STEP 6. PLACE IGNITION SWITCH TO THE OFF POSITION.

ME 4930-207-12/2-6

Figure 2-6. Stopping the engine.

b. Emergency Stopping. Turn the ignition switch (fig. 2-6) to the off position.

2-12. Operation of Equipment

- a.* Start the engine (para 2-10).
- b.* Refer to following paragraphs for complete operation of the lubricating servicing unit.

2-13. Filling Lubricant Tanks

- a.* Start the engine (para .2-10) and allow it to warm up to normal operating temperature.
- b.* Engage the clutch lever (fig. 2-5) by moving it toward the hose reels.

NOTE

Engage the clutch slowly, allowing enough time for the compressor to gain speed before fully engaging the clutch.

c. Close the master air valve (fig. 2-4) at the air receiver.

d. Air pressure in the air receiver will automatically build up to 170 lbs. This pressure is pre-set to cut at 175 lbs. pressure and cut in at 150 lbs. pressure.

e. Allow pressure to build up until the air receiver pressure gage (fig. 2-4) shows a reading of between 150 and 175 lbs. pressure.

f. Remove transfer pump (fig. 1-1) from its mounting and install it in drum of lubricant to be dispensed.

NOTE

Heavy grease cannot be pumped and will have to be packed manually.

g. Remove the transfer pump hose from tool box and install it on the transfer pump as illustrated in figure 2-7.

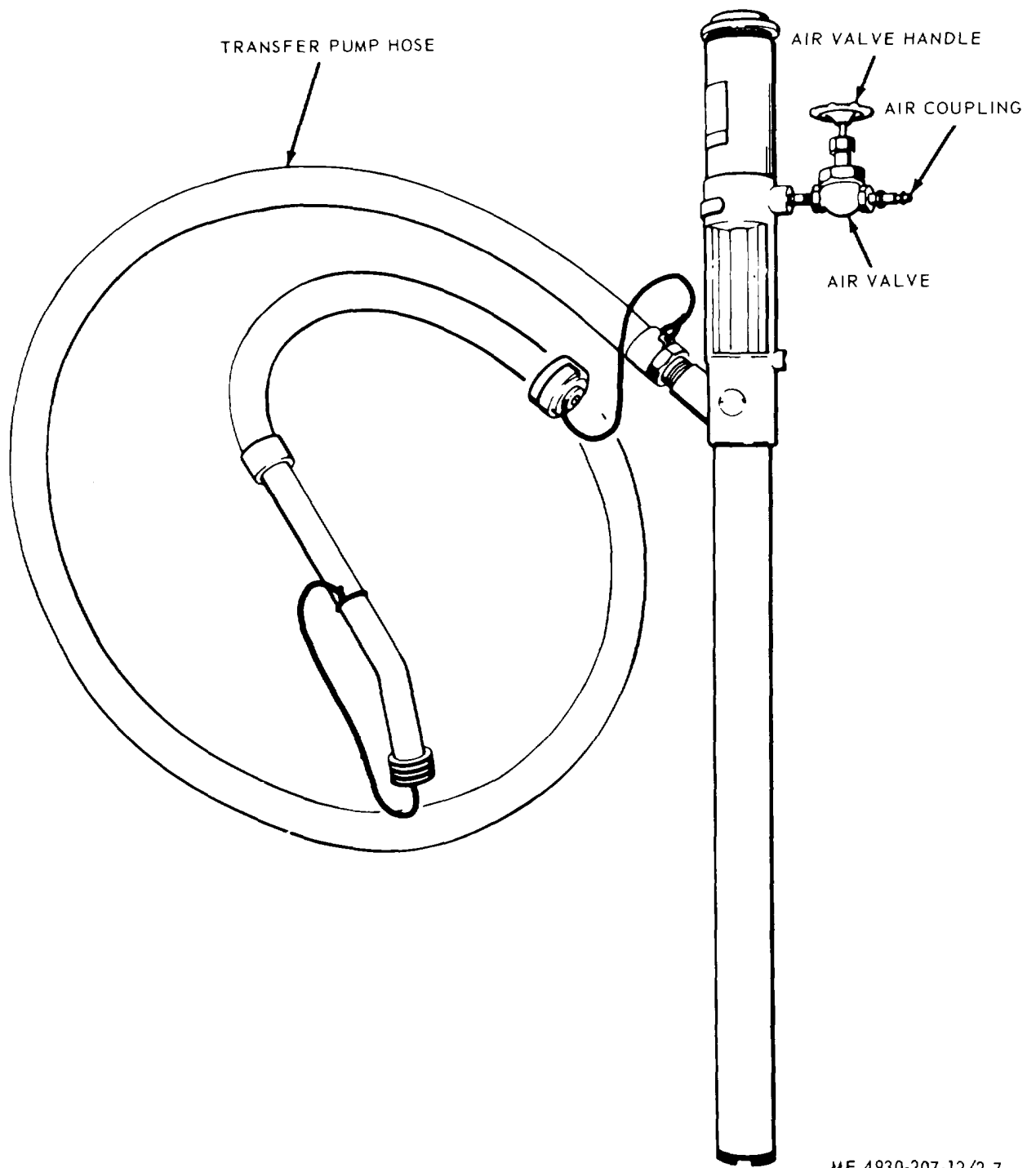

ME 4930-207-12/2-7

figure 2-7. Transfer pump operation.

h. Pull out the air hose (fig. 2-4) and connect it to the air coupling (fig. 2-7) on the transfer pump air valve.

i. Open fill covers on lubricant tanks (fig. 1-2), and insert transfer pump hose into tank to be filled.

j. Open master air valve (fig. 2-4) and the transfer pump air valve and pump the lubricant into the lubricant container to the required level.

NOTE

Always keep lubricant container three-quarter full.

k. Stop the engine (para 2-11 i).

l. Clean and store the transfer pump and close the master valve (fig. 2-4). Open air receiver drain valve and drain the moisture from the air receiver.

2-14. Preparing Lubricant Pumps for Operation

a. Fill the lubricant tanks (para 2-13).

b. Prepare the lubricant pumps for operation as illustrated in figure 2-8.

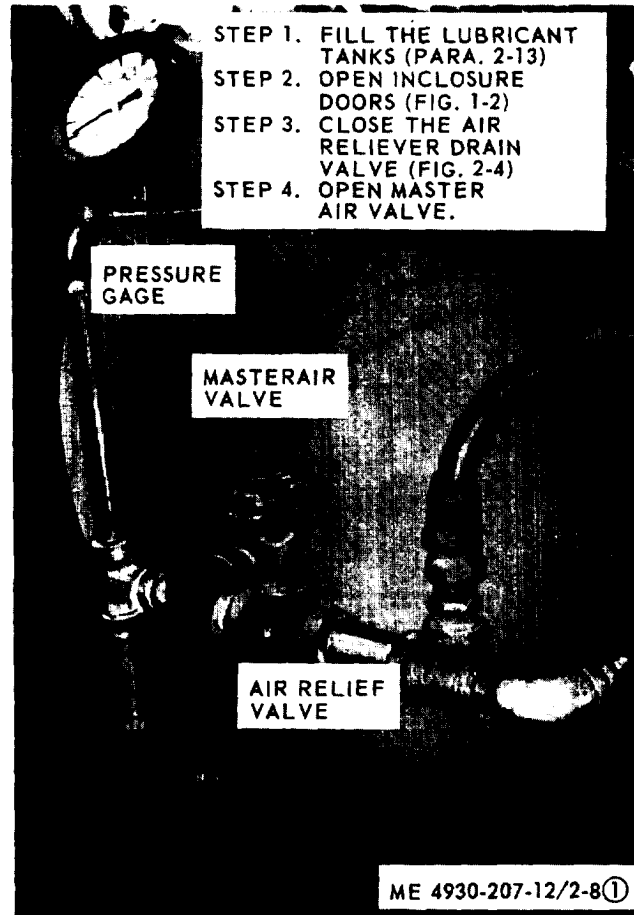
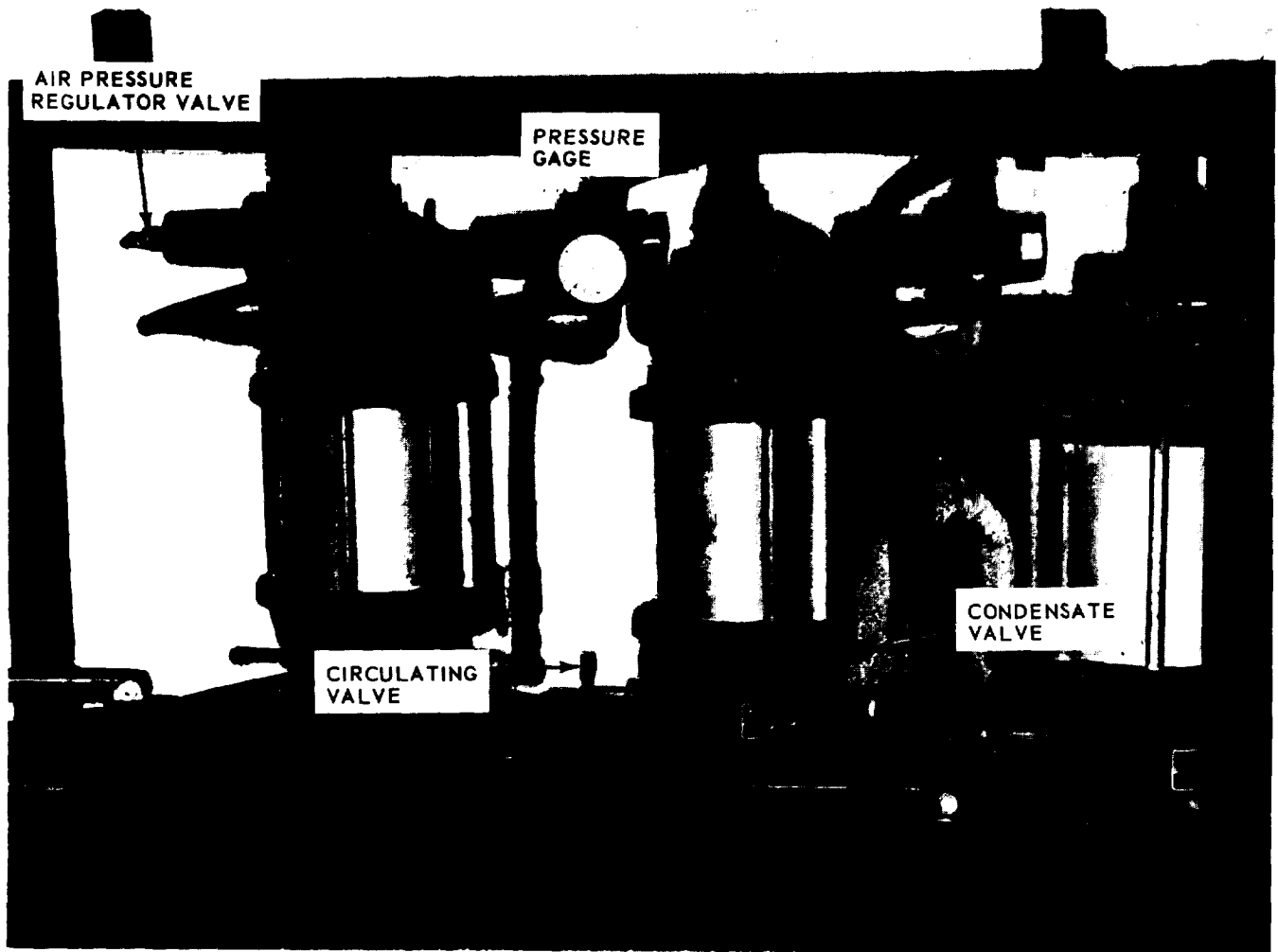

Figure 2-8. Preparation lubricant pumps for operation (sheet 1 of 3).



STEP 5. OPEN AIR PRESSURE REGULATOR VALVE BY TURNING CLOCKWISE TO CONTROL PRESSURE AND SPEED OF PUMP.

STEP 6. TURN AIR PRESSURE REGULATOR CLOCKWISE UNTIL DESIRED PRESSURE IS REACHED ON PRESSURE GAGE.

NOTE: AIR PRESSURE TO EACH PUMP MUST BE ADJUSTED AT THE INDIVIDUAL PUMP. EXACT PRESSURE TO OPERATE PUMP MUST BE BASED ON DELIVERY RATE REQUIRED AND THE TEMPERATURE OF LUBRICANT.

STEP 7. OPEN CIRCULATING VALVE BY TURNING VALVE HANDLE TWO FULL TURNS COUNTERCLOCKWISE.

STEP 8. AFTER CHARGING PUMP WITH LUBRICANT, CLOSE CIRCULATING VALVE BY TURNING TWO TURNS CLOCKWISE.

ME 4930-207-12/2-8②

*Figure 2-8. Preparing lubricant pumps for operation
(sheet 2 of 3).*

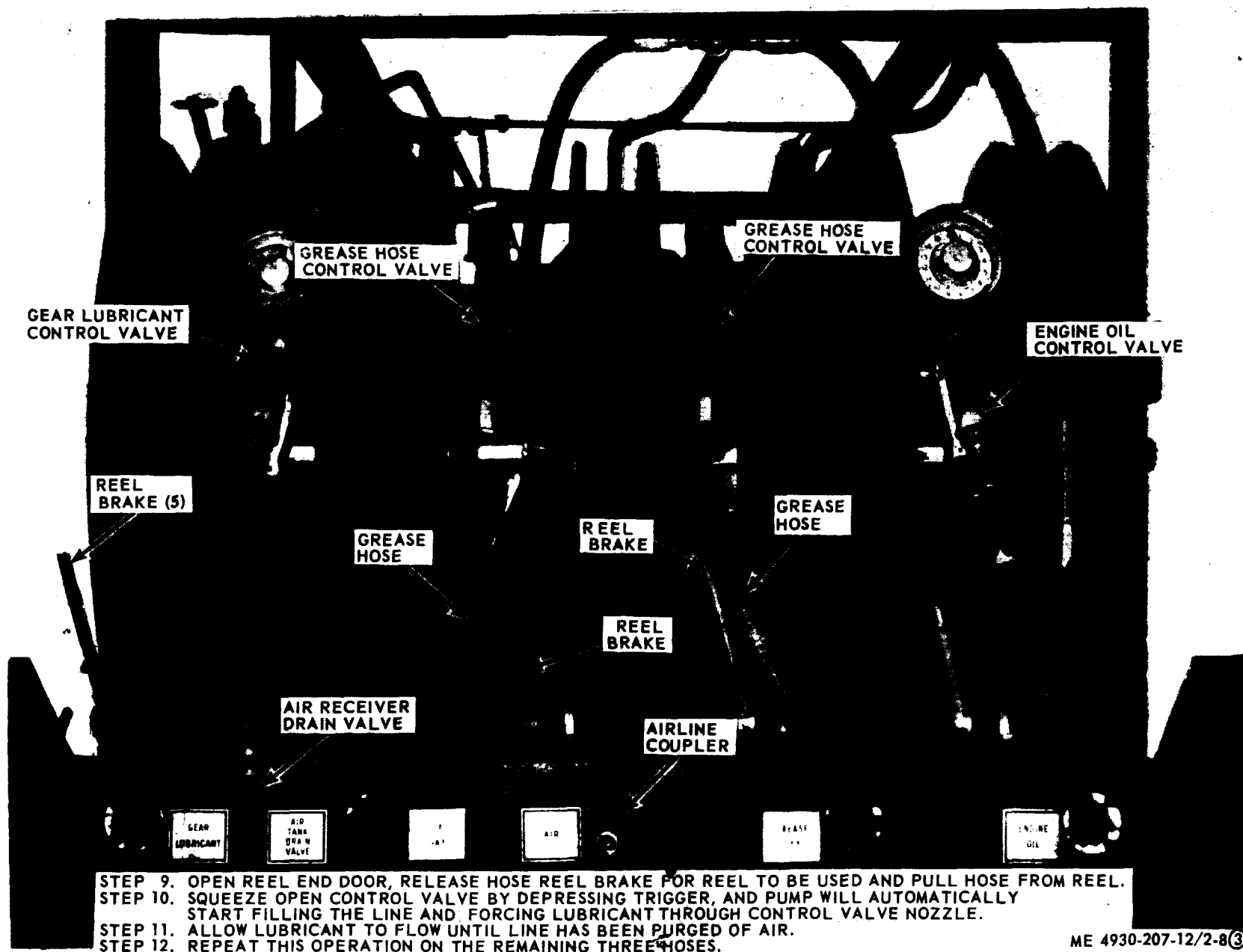

Figure 2-8. Preparing lubricant pumps for operation
(sheet 3 of 3).

2-15. Dispensing Lubricant

a. *General Purpose Grease.* Dispense general purpose grease as illustrated in figure 2-9.

b. *Gear Oil.* Dispense gear oil as illustrated in figure 2-10.

c. *Dispensing Engine Oil.* Dispense engine - oil as illustrated in figure 2-11.

d. *Use of Air Gage Inflator.*

(1) Remove the air gage inflator (20, fig. 2-12) from the lower accessory drawer and attach the gage to the air line coupler (fig. 2-4).

(2) Press the air chuck down firmly on the tire valve, pull trigger on the air gage inflator and inflate the tire. Release trigger periodically and check the tire pressure which will show on the gage. When proper pressure is reached, lift the air gage inflator

off the tire valve, The air then shuts off automatically.

WARNING

When inflating tires, stand to one side of the tire, not in front of it. Serious injury could result if the tire blows off the rim.

(3) After servicing operation has been performed, rewind the air hose reel, set the reel brake, disconnect the air gage inflator and place it in the accessory drawer.

2-16. Shutdown Procedure

a. Shut down the lubricating unit as illustrated in figure 2-13.

b. Close the lubricator enclosure doors.

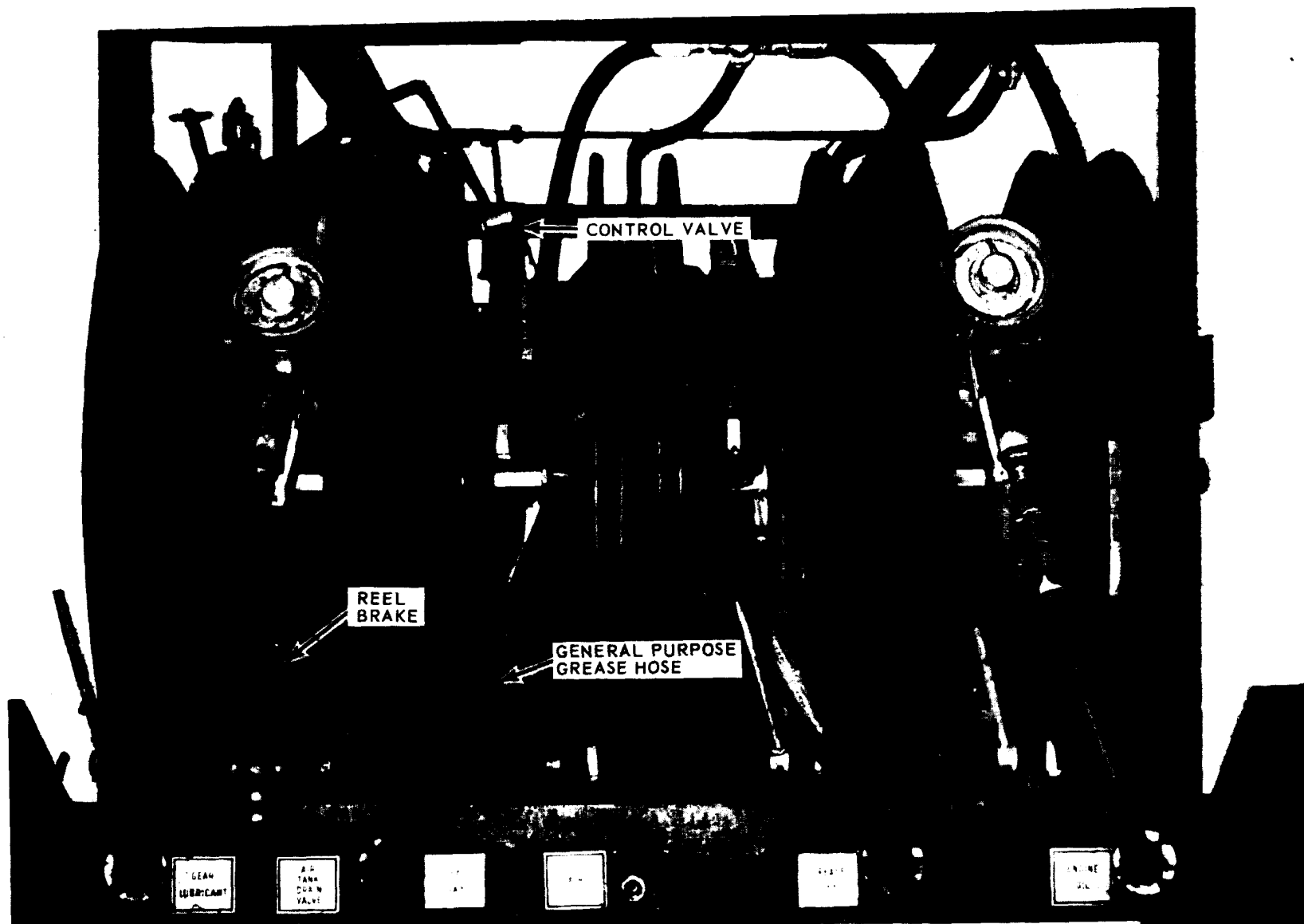

- STEP 1. PREPARE LUBRICATION PUMPS FOR OPERATION (PARA 2-14)
 STEP 2. RELEASE REEL BRAKE AND PULL OUT REQUIRED LENGTH OF HOSE
 STEP 3. ATTACH PROPER ADAPTER FROM LOWER DRAWER
 STEP 4. CLEAN FITTING ON PART TO BE LUBRICATED, ATTACH ADAPTER AND SQUEEZE TRIGGER
 STEP 5. WHEN GREASE IS FORCED OUT OF PART BEING LUBRICATED, RELEASE TRIGGER AND GO ON TO NEXT FITTING.
 STEP 6. WHEN GREASE IS FORCED OUT OF PART BEING LUBRICATED, RELEASE TRIGGER AND GO ON TO NEXT FITTING.
 STEP 7. AFTER LUBRICATION IS COMPLETE, DISCONNECT AND CLEAN ADAPTER AND RETURN TO LOWER DRAWER.

ME 4930-207-12/2-9

Figure 2-9. Dispensing general purpose grease.

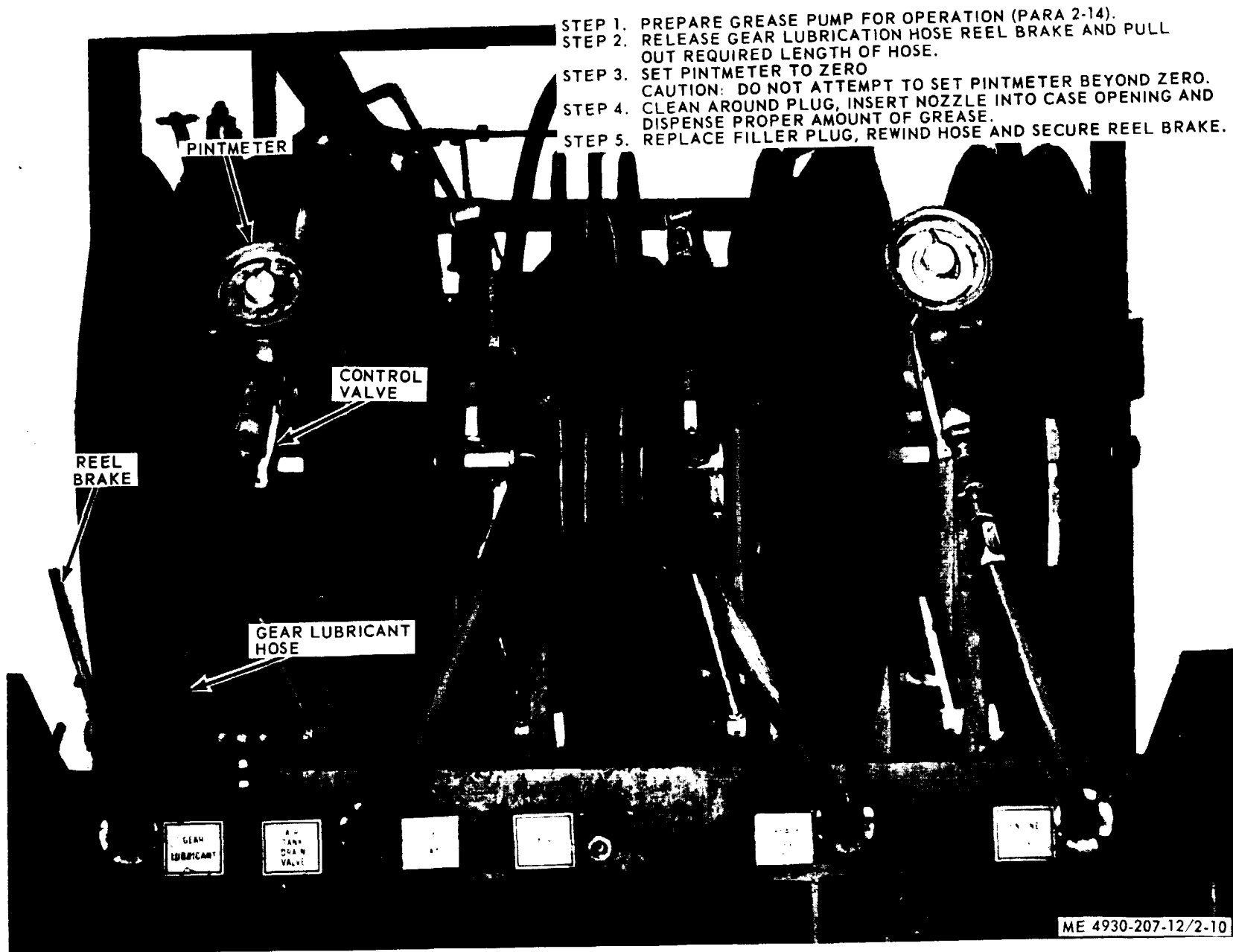

Figure 2-10. Dispensing gear oil.

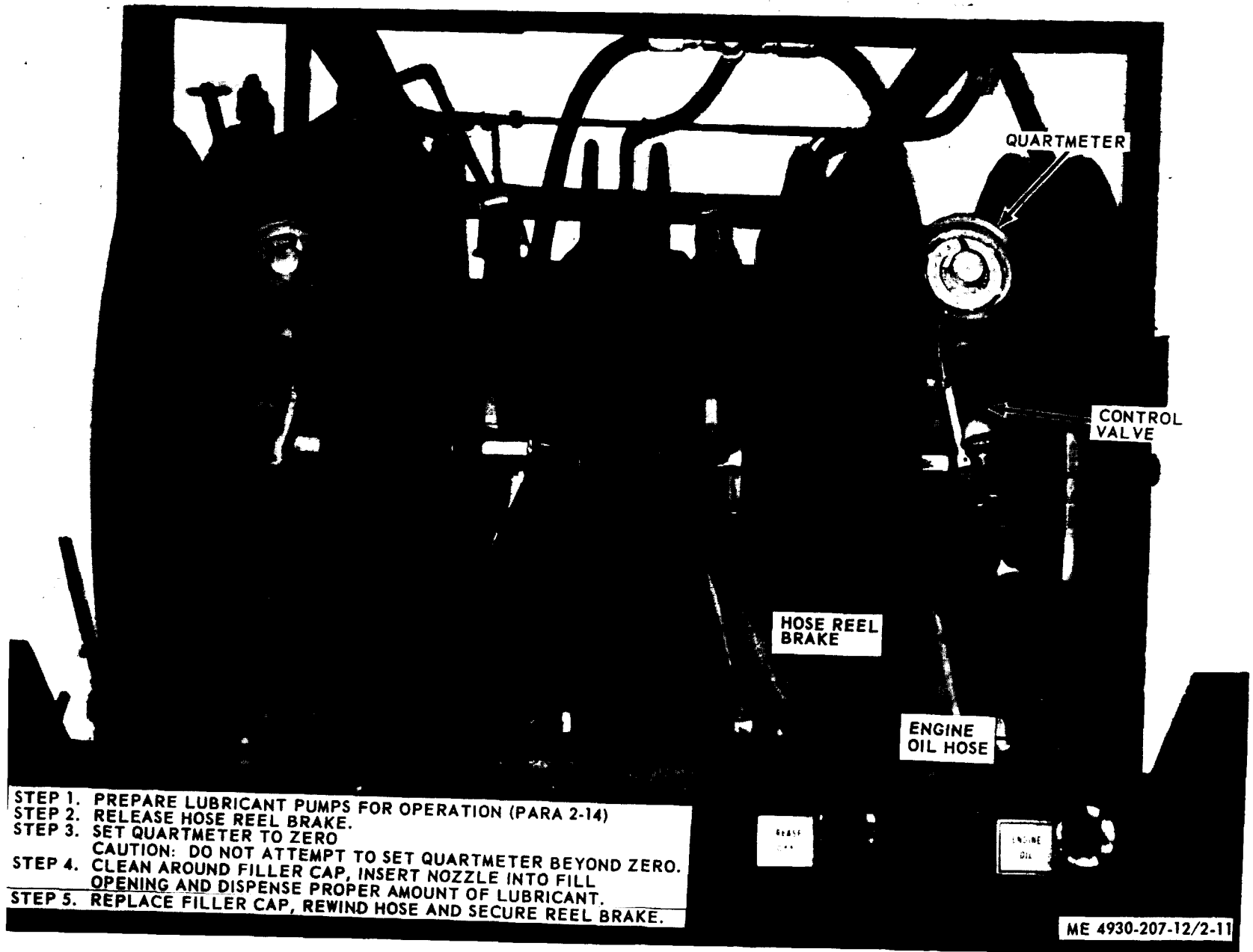

Figure 2-11. Dispensing engine oil.

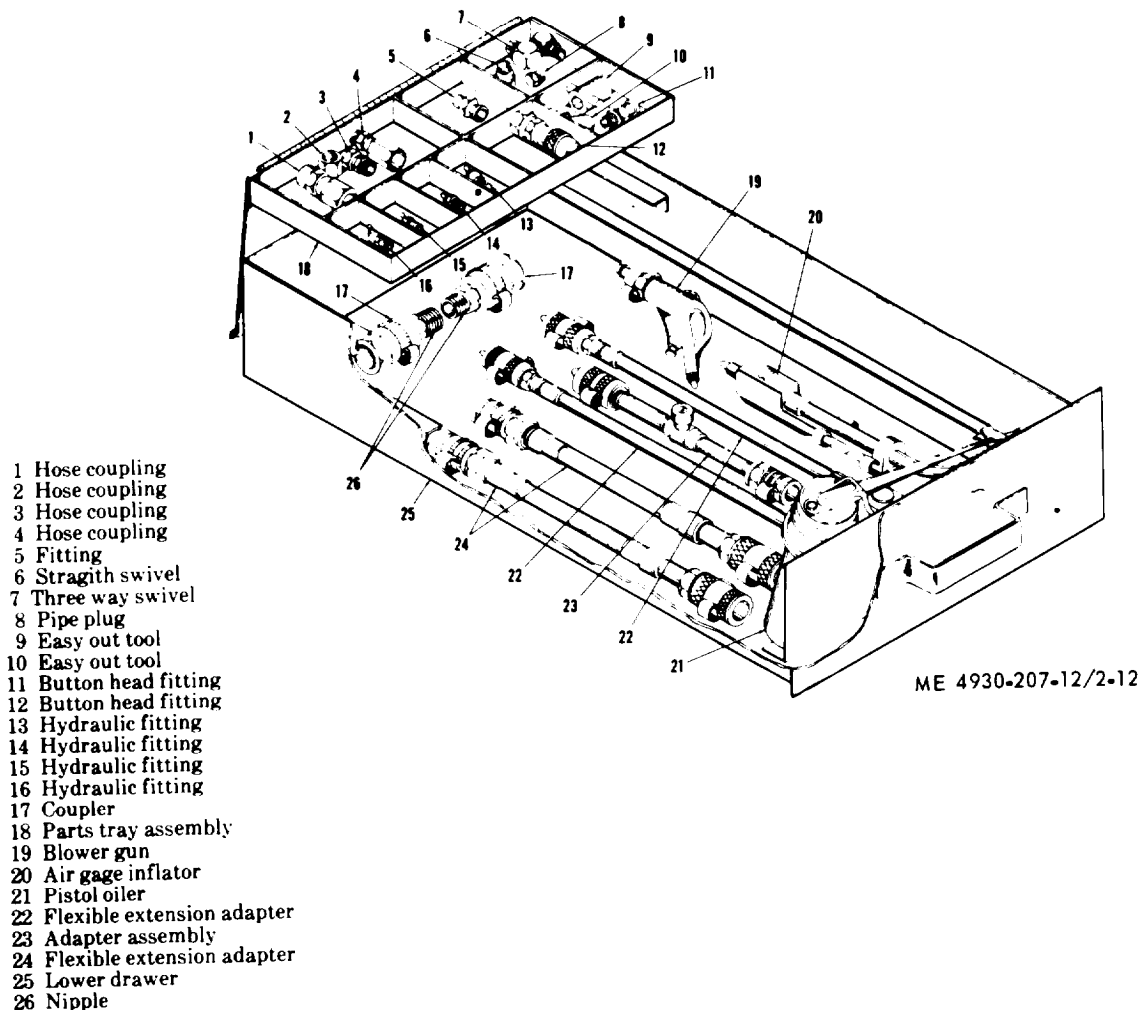
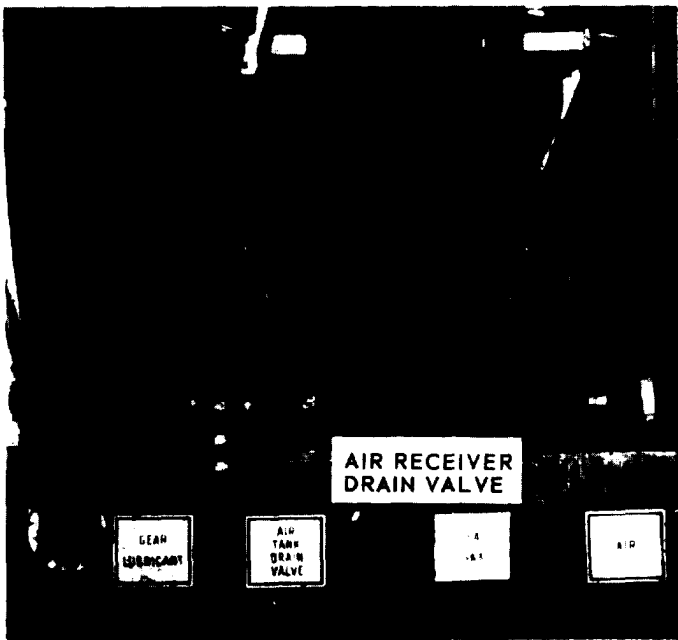
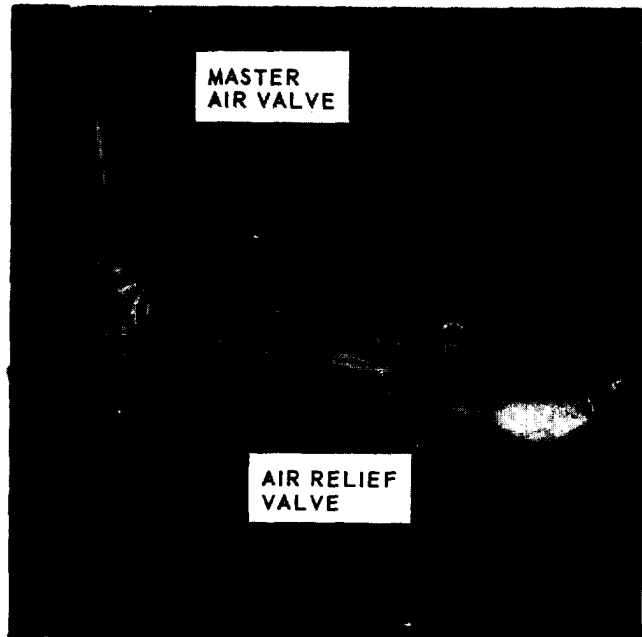

Figure 2-12. Lower drawer and accessories.



- STEP 1. WITH PUMPS OPERATING
TURN CONDENSATE VALVE
CLOCKWISE TO BLEED AIR
AND MOISTURE FROM SYSTEM.
- STEP 2. DISENGAGE CLUTCH (FIG 2-4)
- STEP 3. STOP THE ENGINE (PARA 2-11)
- STEP 4. CLOSE MASTER AIR VALVE AND
OPEN AIR PRESSURE RELIEF
VALVE TO RELEASE PRESSURE
FROM AIR RECEIVER.
- STEP 5. OPEN AIR RECEIVER DRAIN VALVE TO
DRAIN MOISTURE FROM AIR RELIEVER.

ME 4930-207-12/2-13

Figure 2-13. Shutting down the lubricating unit.

Section V. OPERATION UNDER UNUSUAL CONDITIONS

2-17. Operation in Extreme Cold

a. General. Operating the lubricating and servicing unit in extremely cold temperatures presents special problems. Lubrication, fuel, electrical and air system components are all affected by cold weather operation.

b. Care of Lubricants. Keep lubricants in tightly closed containers and, if possible, in a warm protected place to insure ease of handling. Remove all snow

and ice from the containers before opening to transfer lubricants to tanks or guns.

c. Special Equipment. The lubricating and servicing unit is equipped with an alcohol dispenser and an exhaust heat diverter for cold weather operation.

(1) Alcohol dispenser.

(a) The alcohol dispenser (fig. 2-14) is used to inject alcohol into the air lines leading to the lubricant pumps to prevent condensation and freezing.



Figure 2-14. Alcohol dispenser- service and operation.

(b) Operate and service the alcohol dispenser as illustrated in figure 2-14.

Table 2-1. Alcohol Dispenser Valve Setting/g

40 psi to pumps	Valve must be opened	80 psi to pumps	Valve must be opened	120 psi to pumps	Valve must be opened
1 pump	2 turns	1 pump	1½ turns	1 pump	1 turn
2 pumps	1½ turns	2 pumps	1 1/8 turns	2 pumps	¾ turn
3 pumps	1 turn	3 pumps	¾ turn	3 pumps	½ turn

NOTE 1: For dispensing approximately 9 ounces per hour, operating one, two, or three pumps (with pumps operating at 24 cycles per min.)

NOTE 2: Higher pump operating pressure and faster cycling automatically will increase the amount of alcohol dispensed, so that needle valve must be proportionately closed to maintain the desired flow.

(2) Exhaust heat diverter.

(a) The exhaust diverter lever (fig. 2-4) directs heat from the engine exhaust to a reservoir beneath the lubricant tanks or exhausts heat to the atmosphere.

(b) In cold weather operation, duct exhaust gases to heat reservoir.

(c) Start engine (para 2-11) and close all enclosure doors (fig. 1-2).

(d) Allow engine to run about ten minutes, then start the compressor. Wait until compressor unloads before using lubricating pumps.

d. Lubrication. Refer to LO 5-4930-207-12 for proper lubrication

e. Electrical System. Inspect, clean and tighten all electrical connections, especially battery terminals. Keep batteries fully charged at all times.

f. Fuel System.

(1) Remove snow and ice from fuel tank filler cap before servicing the fuel tank.

(2) Keep filler cap tight at all times to keep moisture and dirt from the tank.

(3) Keep the fuel tank full when not in operation to prevent condensation.

g. Air Cleaner. Refer to TM 5-2805-203-14 and service the engine air cleaner at regular intervals.

h. Compressor Air Cleaner. Service the compressor air cleaner at regular intervals (para 3-18).

i. Air System. Open air receiver drain valve (fig. 2-4) and drain the moisture from the air receiver at regular intervals.

2-18. Operation in Extreme Heat

a. When operating in extreme high temperatures, efficient cooling and adequate lubrication of the engine and air compressor is vitally important.

b. Check the engine cooling shrouds to make sure the air circulation is not restricted through the engine shrouds and fins. Refer to TM 5-2805-203-14 and service the engine air cleaner at normal intervals.

Lubricate the unit more frequently.

2-19. Operation in Dusty or Sandy Areas

a. Refer to LO 5-4930-207-12 and lubricate the unit at more frequent intervals.

b. Make frequent inspections of the engine and compressor cooling shrouds and fins to make sure the air flow for cooling is not restricted.

c. Inspect the fuel filter bowl for sediment at frequent intervals. Service fuel filter as often as necessary (para 3-13).

d. Remove accumulations of sand and dirt from the unit as often as necessary.

e. Exercise precautions to keep dirt from entering the fuel system while servicing the fuel tank.

f. Keep all enclosure doors closed during shut down periods.

2-20. Operation in Rainy or Humid Conditions

a. Pay special attention to exposed machined parts. Apply a thin coat of engine oil to exposed parts to prevent rusting.

b. Keep electrical components clean and dry.

2-21. Operation in Salt Water Areas

a. Pay special attention to exposed machined surfaces. Keep a thin coat of engine oil on all exposed parts and keep as clean and free of moisture as possible.

b. Make sure all unpainted spots are painted or coated with a rust preventive compound.

c. When equipment has been exposed to salt water, steam clean or wash exposed areas with clean, fresh water as soon as possible. Dry thoroughly.

2-22. Operation at High Altitudes

The air pressure above sea level decreases as the altitude is increased. The result is a decrease in air to the carburetor, causing too rich a fuel mixture. If this condition interferes with engine operation, refer to TM 5-2805-203-14 and adjust the carburetor.

Section VI. OPERATION OF MATERIAL USED IN CONJUNCTION WITH THE EQUIPMENT

2-23. General

The auxiliary material used in conjunction with the lubricator consists of a set of hand guns, oil spray gun, air blower valve, portable lubricator, the necessary accessory equipment and a fire extinguisher.

2-24. Hand Guns

a. General. A set of hand guns, adapters and coup-

lers (fig. 2-12 and 2-15) are located in the accessory drawers below the hose reels. These hand guns are used to dispense small quantities of lubricants other than general purpose grease and for emptying and filling transmissions or gear boxes.

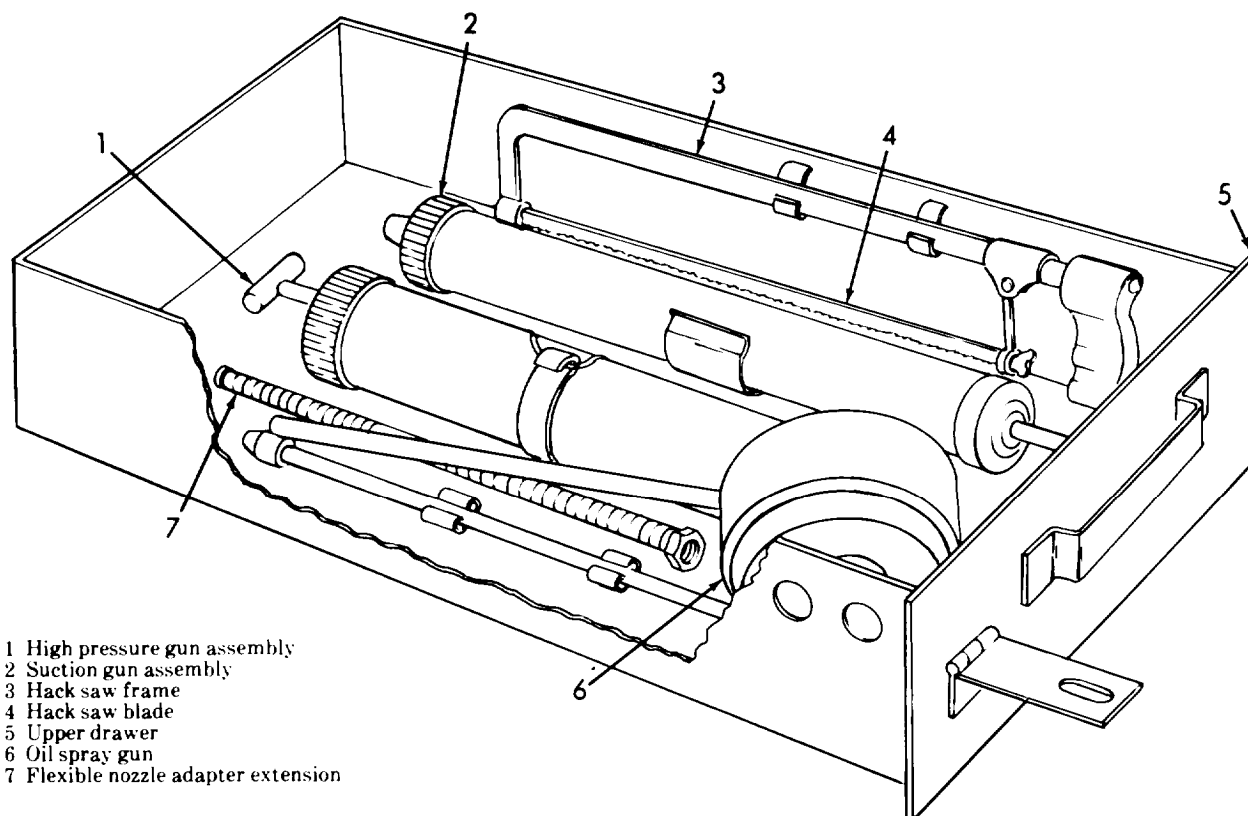

- 1 High pressure gun assembly
- 2 Suction gun assembly
- 3 Hack saw frame
- 4 Hack saw blade
- 5 Upper drawer
- 6 Oil spray gun
- 7 Flexible nozzle adapter extension

ME 4930-207-12/2-15

Figure 2-15. Upper drawer and accessories

b. Hand Lever Gun. The high pressure hand lever gun (1, fig. 2-15) is used for lubricants required in small quantities, or for dispensing special lubricants. When operating the hand lever gun, best results are obtained by taking full strokes with the lever handle. If a heavy lubricant is used, it may be necessary to prime the lever gun occasionally. Special couplers and adapters provide contact for all types of fittings. To fill the lever gun proceed as follows:

(1) *Pressure fill.*

(a) Pull back on the handle and turn counter-

clockwise until it is seated firmly in the coupling.

(b) Push the handle forward until it reaches end of stroke.

(c) Hold gun so that lever arm falls into position when the piston is pulled out to a full stop.

(d) Attach a grease hose to lubrication fitting on head of gun.

(e) Operate grease hose valve until cylinder is full as indicated by handle being forced out to a full stop.

(2) *Manual fill.*

(a) *Unscrew head lever* from gun cylinder.

(b) Engage follower and push it into a full stop.

(c) place open end of cylinder into lubricant container, approximately 2 inches. Pull handle slowly out all the way.

(d) If the lubricant container is not completely full, pack tight by hand to eliminate air pockets.

(e) Replace head and lever assembly.

c. *Suction Gun.*

(1) Use the suction gun (2, fig. 2-15) for emptying or filling transmissions, differentials or gear boxes that cannot be drained.

(2) Fill the suction gun by inserting the nozzle into oil or fluid. Pull out handle as far as it will go.

(3) When used for filling purposes it is filled as in (2) above. Insert the nozzle into case to be filled and push the handle forward until a sufficient quantity of oil has been delivered.

d. *Pistol Oiler.* The pistol oiler (21, fig. 2-12) is used for applying small quantities of oil to friction points. Operate the pistol oiler by squeezing the trigger.

2-25. Oil Spray Gun

a. *General.* The air operated oil spray gun (6, fig. 2-15) is used to obtain oil spray at high pressure. The gun consists of an oil container and a head with an air valve. Separate controls adjust input quantity of air and the quantity of air ejected. An adjustable nozzle permits either a steady stream, or spray type oil ejection.

b. *Operation.*

(1) Fill the spray gun container with the desired grade of oil.

(2) Screw the container into the spray gun head and attach air line coupler of the spray gun to the air line coupler (fig. 2-4).

(3) Turn the adjustable nozzle to the closed position. Press the air valve button and open the nozzle until desired amount of oil ejection is obtained.

2-26. Air Blower Gun

The air blower gun (19, fig. 2-12) may be attached to the air line coupler (fig. 2-4) and used to clean parts with compressed air.

2-27. Accessory Equipment

a. *Air Chuck and Gage.* An air gage inflator (20, fig. 2-12) with a quick-disconnect air line coupling, used to inflate tires, is located in the lower accessory drawer.

b. *Hack Saw Frame and Blade.* A hack saw frame (3, fig. 2-15) and blade (4) used for cutting hoses, is

located in the upper accessory drawer.

c. *Padlock.* Two padlocks (fig. 1-1) with two interchangeable keys per lock are used for locking the tool box and accessory drawers.

d. *Air Line Coupling and Nipple* Two air line couplings (17, fig. 2-12) with nipples (26) to replace socket or nipple when necessary, are located in the lower accessory drawer.

e. *High Pressure Hose End Couplings.* Two high pressure hose end couplings (1 and 2, fig. 2-12) for use with high pressure lubricant hoses are located in the lower accessory drawer.

f. *Air Hose End Couplings.* Two each male and female reusable hose end couplings (3 and 4, fig. 2-12) used to replace hose end fittings of ¼ in. inside diameter air hoses, are located in the lower accessory drawer.

g. *Hose Adapter Coupling.* Two hose adapter couplings (22, fig. 2-12) used to join high pressure lubricant hoses are located in the lower accessory drawer.

h. *Flexible Extension Hoses.* Two giant button head, whip end, flexible extension adapters (24) each with a 500 psi pressure relief valve, and equipped with giant button head fittings are part of the accessory equipment. One hose assembly is attached to the control valve (fig. 2-8) on the grease hose reel. The other is a replacement part and is stored in the lower drawer.

i. *Button Head Fittings.* Six each button head fittings (5, 11, and 12, fig. 2-12) to be used as replacement parts are located in the lower drawer.

j. *Extension Hydraulic Pressure Relief Adapter.* One flexible extension adapter (23) with a 500 psi pressure relief valve is furnished with the lubricating unit. The adapter is used for greasing seal-type lubrication points, to prevent rupturing seals when using power lubrication equipment. A sliding sleeve locks firmly on the coupler of the hydraulic adapter.

k. *Straight Hydraulic Fittings.* Six each straight hydraulic fittings (13, 14 and 15) to replace fittings of varying sizes are located in the lower drawer.

l. *45° Hydraulic Fittings.* Six each 45° hydraulic fittings (16) to replace defective fittings, if necessary, are located in the lower drawer.

m. *Easy Out Tool.* Two easy out tools (9 and 10) are used for removing grease fittings. They are located in the lower drawer.

n. *Straight and "Z" Swivels.* Two straight and "Z" swivel (6 and 7) are used for connecting the control valves to the supply hoses; thus permitting the valve to swivel for easy access to hard-to-reach fittings. The swivels are located in the lower drawer.

2-28. Portable Lubricator

a. *Description.* The portable lubricator (fig. 2-16)

is a self-contained unit and can be strapped to the operator's back. An air powered piston forces grease to a booster valve, where pressure is built up by

squeezing the valve handle. The portable lubricator is stored in a bracket just above the fuel tank.

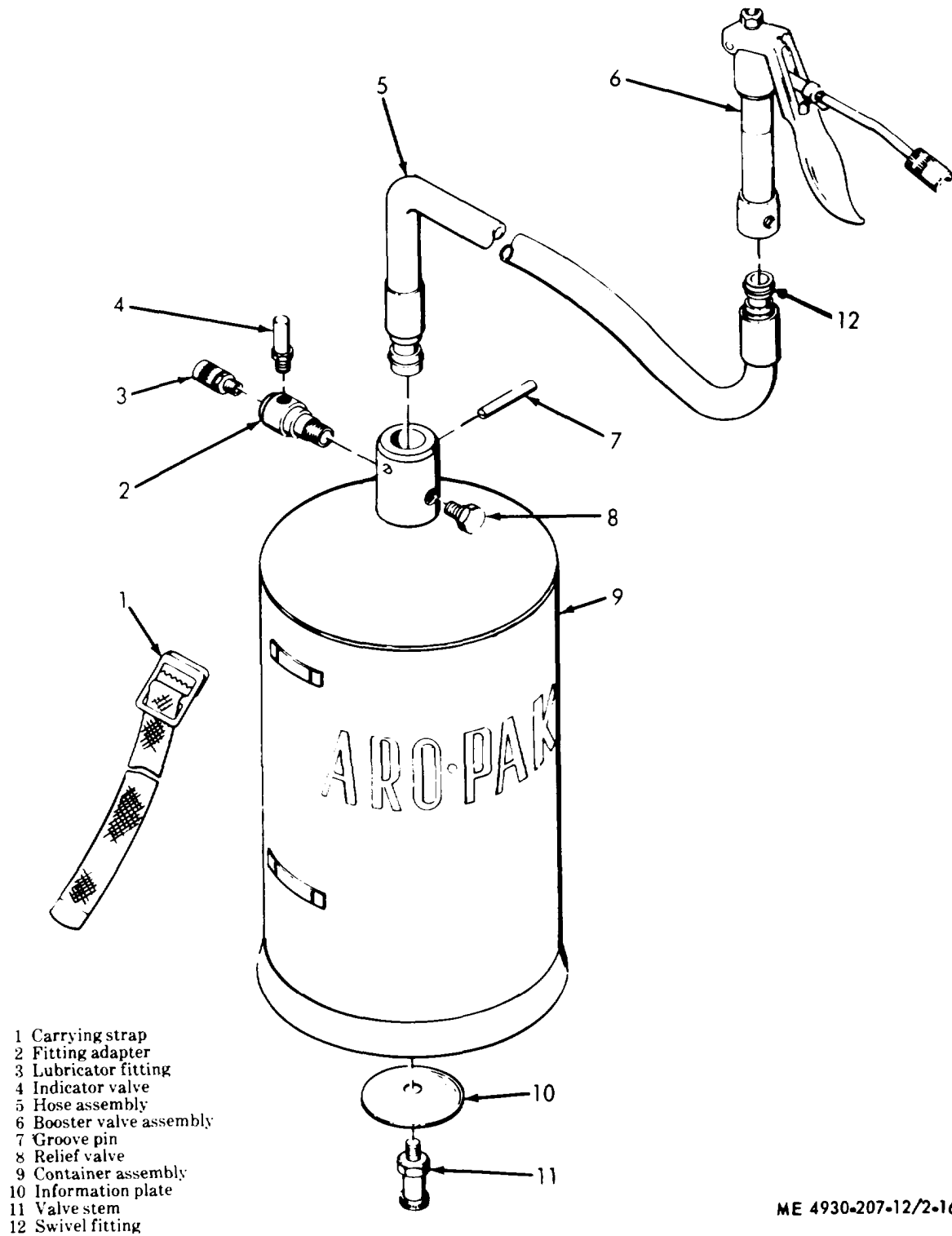

ME 4930-207-12/2-16

Figure 2-16. Portable lubricator assembly.

b. Operation.

(1) With the portable lubricator empty of grease, remove the valve cap from the valve stem (11) and charge the container assembly (9) with air pressure to 40 psi.

(2) Remove groove pin (7) and insert hose assembly (5) into connector as far as it will go. Replace groove pin (7) to its full length and check to be sure hose assembly (5) fits into connector.

(3) Fill the lubricator with grease until the indicator valve (4) shows full. Do not overfill.

(4) Insert other end of hose assembly (5) into body of booster valve assembly (6) and screw in the swivel fitting (12), hand tight.

(5) Open the air relief valve on the booster valve assembly (6) until grease flows in a steady stream. Close the relief valve. The lubricator is now ready for use.

NOTE

The portable lubricator need not be refilled with air each time grease is completely expelled. The air charge will last approximately one year.

2-29. Fire Extinguisher

a. Description. The portable carbon dioxide type fire extinguisher is mounted within the right side of the lubricating and servicing unit enclosure near the compressor. The fire extinguisher is suitable for electrical and flammable liquid fires.

b. Operation. Remove fire extinguisher from its location; break the seal, operate the control valve and direct the stream at the base of the flame.

c. Maintenance. For maintenance of the fire extinguisher, refer to TB 5-4200-200-10.

CHAPTER 3
OPERATOR'S MAINTENANCE INSTRUCTIONS

Section I. OPERATOR AND ORGANIZATIONAL MAINTENANCE TOOLS AND EQUIPMENT

3-1. Special Tools and Equipment

No special tools and equipment are required by operator and organizational maintenance personnel for performing maintenance on the lubricating and servicing unit.

3-2. Basic Issue Items

Basic Issue Items authorized for use with the lubri-

ating and servicing unit are listed in the basic issue items list, Appendix C of this manual.

3-3. Organizational Maintenance Repair Parts

Repair parts issued with or authorized for use with the lubricating and servicing unit are listed in TM 5-4930-207-20P.

Section II. LUBRICATION INSTRUCTIONS

3-4. General Lubrication Information

This section contains lubrication instructions which are supplemental to, and not specifically covered in the lubrication order.

3-5. Detailed Lubrication Information

a. General. Keep all lubricants in closed containers and store in a clean, dry place away from external heat. Allow no dust, dirt or other foreign material to mix with lubricants.

b. Cleaning. Keep all external parts not requiring lubrication clean of lubricants. Before lubricating the equipment, wipe all lubrication points free of dirt

and grease. Clean all lubrication points after lubricating to prevent accumulation of foreign matter.

c. Points of Lubrication.

(1) Service the lubrication points at proper intervals as illustrated in LO 5-4930-207-12.

(2) The engine crankcase oil level must be checked frequently, as oil consumption may increase.

(3) The oil may require changing more frequently than usual because contamination by dilution and sludge formation will increase under cold weather operation conditions.

d. Oil Filter. Refer to TM 5-2805-203-14 and service the engine oil filter.

Section III. OPERATOR'S PREVENTIVE MAINTENANCE CHECKS AND SERVICES

3-6. General

To insure that the lubricating and servicing unit is ready for operation at all times, it must be inspected systematically so defects may be discovered and corrected before they result in serious damage or failure. Defects discovered during operation of the unit will be noted for future correction, to be made as soon as operation has ceased. Stop operation immediately if a deficiency is noted during operation which would damage the equipment if operation were continued. All deficiencies and shortcomings will be recorded

together with the corrective action taken on DA Form 2404 (Equipment Inspection and Maintenance Worksheet) at the earliest possible opportunity.

3-7. Preventive Maintenance Services

Table 3-1 contains a tabulated list of preventive maintenance checks and services which must be performed by the operator and crew. Item numbers indicate the sequence of minimum inspection requirements and the interval column designates the required service intervals.

Table 3-1. Preventive Maintenance Checks and Services (Operator and Crew)

Item number	Interval				Org.		Item to be inspected	Procedure	Reference
	Operator				M	Q			
	B	D	A	w					
1	x						Tires	Check for proper inflation.	Para 1-4
2	x						Air brake reservoir	Drain moisture from tank. Inspect for leaks and loose mountings.	Para 3-19
3	x		x				Lights	Check for proper operation and defective wiring.	
4							Fire extinguisher	Check condition of the fire extinguisher and inspect for full charge. See that it is properly mounted.	Para 2-29
5	x						Batteries	Check condition of batteries. Maintain proper electrolyte level, Make sure all cables are tight.	Para 3-15
6				x			Alcohol dispenser	Inspect for proper operation, leakage and secure mounting.	Para 3-15
7				x			Belts and pulleys	Inspect condition and tension of generator drive belt. Inspect condition and tension of compressor drive belts.	Para 3-16 Para 3-17
8			x				Tools and equipment	See that all tools and equipment used with the unit are in a serviceable condition. Clean and properly stow all tools and equipment.	Para 2-2
9	x							Inspect cylinder head and cooling fins for any accumulation of dirt or rust.	Para 2-18
10		x					Instruments	Check all gages for broken glass and secure mounting. Check all gages for proper operation.	Para 2-2
11				x			Fuel filter	Inspect filter sediment bowl for accumulation of water or dirt. Clean bowl and screen if dirt or water is present.	Para 3-13
12			x				Fuel	Check fuel supply. See that fuel tank is full.	
13	x						Air compressor	Inspect compressor head and cooling fins for accumulation of dirt and rust.	
14		x					Leaks	Check for lubrication or air leaks. Check swivel joints at hose reel inlet.	
15							Air receiver drain cock	Open air receiver drain cock for a short time to release moisture.	Para 2-13
16		x					Lubricant pumps	Inspect lubricant pumps for leakage. Inspect pump hoses for leaks or damage.	Para 4-30

Section IV. OPERATOR'S TROUBLESHOOTING

3-8. General

This section provides information useful in diagnosing and correcting unsatisfactory operation or failure of the lubricating and servicing unit and its components. Malfunctions which may occur are listed in table 3-2. Each malfunction stated is followed by a list of probable causes of the trouble. The corrective

action recommended is described opposite the probable cause.

3-9. Troubleshooting Table

Table 3-2 lists operator and crew troubleshooting malfunctions, probable causes and corrective action to be taken. Refer to TM 5-2805-203-14 for the military standard engine troubleshooting symptoms.

Table 3-2. Operator and Crew Troubleshooting

Malfunction	Probable cause	Corrective action
1. Tires Wear Unevenly.	<ul style="list-style-type: none"> a. Tires not inflated to proper pres- b. Loose wheels. 	<ul style="list-style-type: none"> a. Inflate tires (para 1-4). b. Tighten wheel mounting bolts (para 4-36).
2. Compressor Overheats.	<ul style="list-style-type: none"> a. Ventilation inadequate. b. Compressor cooling fins dirty. c. Low compressor oil level. d. Dirty air cleaner. 	<ul style="list-style-type: none"> a. Provide adequate ventilation around unit. b. Clean compressor thoroughly. c. Refer to LO 5-4930-207-12 and add oil to proper level. d. Service the air cleaner (para 3-18).
3. Compressor is Noisy.	<ul style="list-style-type: none"> a. Low compressor oil level. b. Compressor V-belts improperly adjusted. 	<ul style="list-style-type: none"> a. Refer to LO 5-4930-207-12 and add oil to proper level. b. Adjust compressor V-belts (para 3-17).
4. Compressor Pumps Too Slow or Fails to Build Up Pressure.	<ul style="list-style-type: none"> a. Air cleaner dirty and clogged. b. V-belts improperly adjusted. c. Low compressor oil level. d. Excessive dirt around compressor cooling fins. 	<ul style="list-style-type: none"> a. Service air cleaner (para 3-18). b. Adjust V-belts (para 3-17). c. Refer to LO 5-4930-207-12 and add oil to proper level. d. Clean compressor thoroughly.
5. Compressor V-Belts Worn Excessively.	<ul style="list-style-type: none"> a. V-belts loose or too tight. b. Oil or grease on V-belts. 	<ul style="list-style-type: none"> a. Replace V-belts (para 4-19). b. Replace V-belts (para 4-19).
6. Insufficient Pressure or Volume with Lubrication Pumps operating	<ul style="list-style-type: none"> a. Exhausted lubricant supply. b. Slow circulation of grease. c. Insufficient air pressure supplied to pump. 	<ul style="list-style-type: none"> a. Refill lubricant containers (para 2-13). b. Push grease down around pump intake priming tube and use exhaust diverter to warm grease. c. Set air regulator to higher pressure (para 2-15). Check for closed or inoperative valves or obstructions (para 2-14).
7. Compressor Oil Consumption is High.	<ul style="list-style-type: none"> a. Leak at filler cap. b. Other causes 	<ul style="list-style-type: none"> a. Replace filler cap. b. Refer other causes to Direct and General Support Maintenance personnel.

Section V. OPERATOR'S MAINTENANCE

3-10. General

Instructions in this section are for the operator's information and guidance in maintenance of the lubricating and servicing unit.

3-11. Engine Air Cleaner

Refer to TM 5-2805-203-14 to service the engine air cleaner.

3-12. Engine Oil Filter

Refer to TM 5-2805-203-14 to service the engine oil filter.

3-13. Fuel Filter

Service the fuel filter as illustrated in figure 3-1.

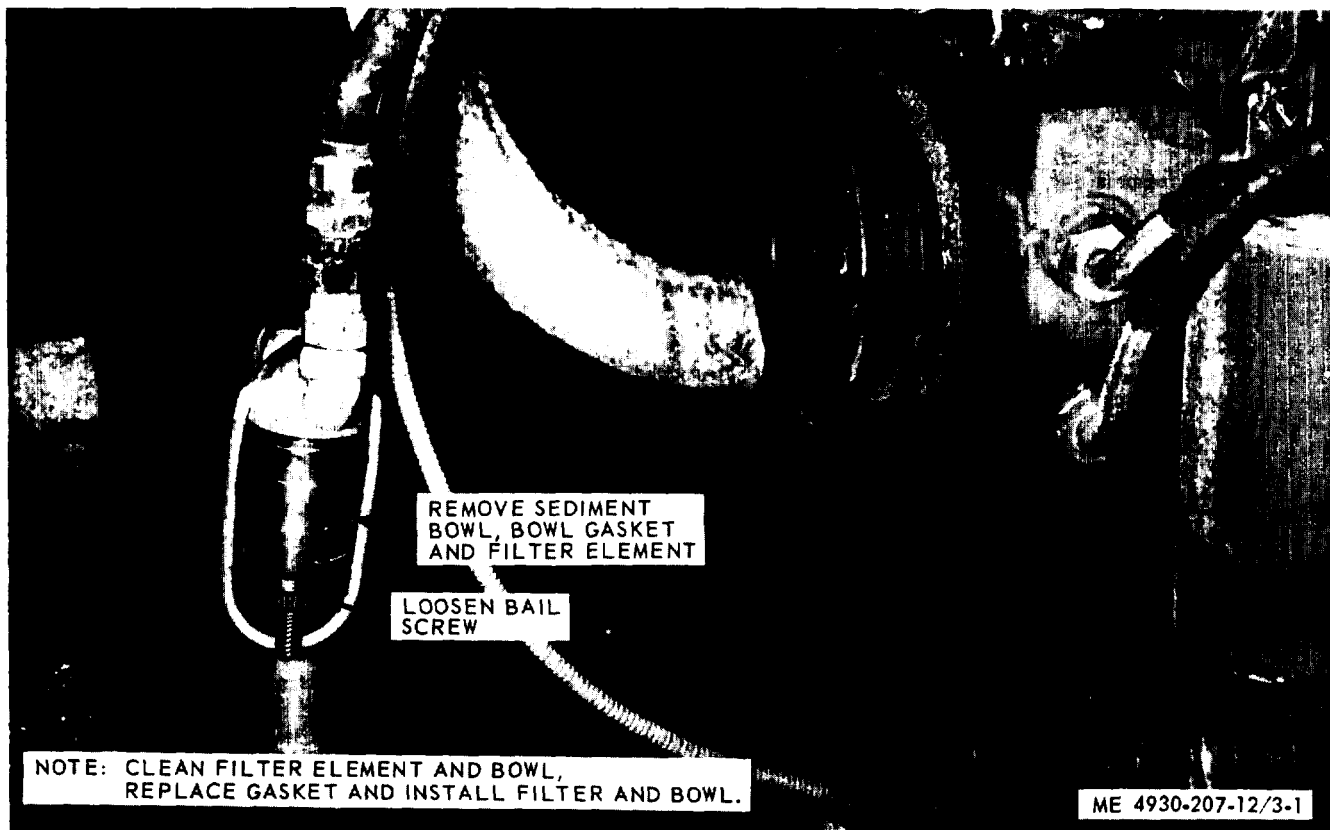

Figure 3-1. Fuel filter service.

3-14. Batteries

Service the batteries as outlined in paragraph 2-3.

3-15. Alcohol Dispenser

Service the alcohol dispenser as illustrated in figure 2-14.

3-16. Generator Drive Belt

a. *Adjustment (fig. 3-2).*

(1) Loosen adjusting link nut at generator.

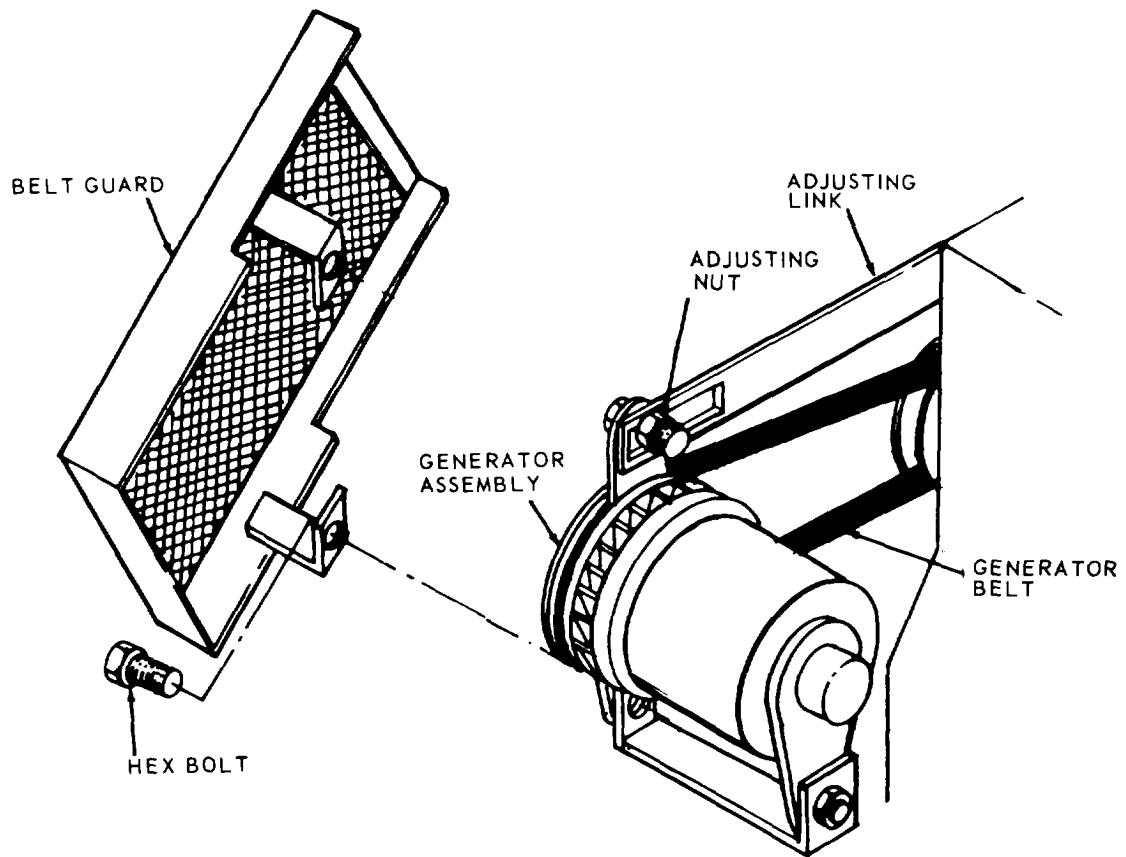

ME 4930-207-12/3-2

Figure 3-2. Generator drive belt adjustment.

(2) Bar generator away from engine to obtain $\frac{1}{2}$ to $\frac{3}{4}$ in. belt deflection midway between the two pulleys.

(3) Tighten adjusting link nut.

b. Belt Replacement (fig. 3-2).

(1) Remove two screws securing belt guard to engine and remove the guard.

(2) Loosen adjusting link nut, remove old belt and install a new one.

(3) Adjust generator belt (*a* above).

(4) Install belt guard and secure to engine with two hex screws.

3-17. Compressor Drive Belt

a. Adjustment (fig. 3-3).

(1) Remove two screws (1, fig. 3-3) securing compressor drive belt guard (2) and remove the guard.

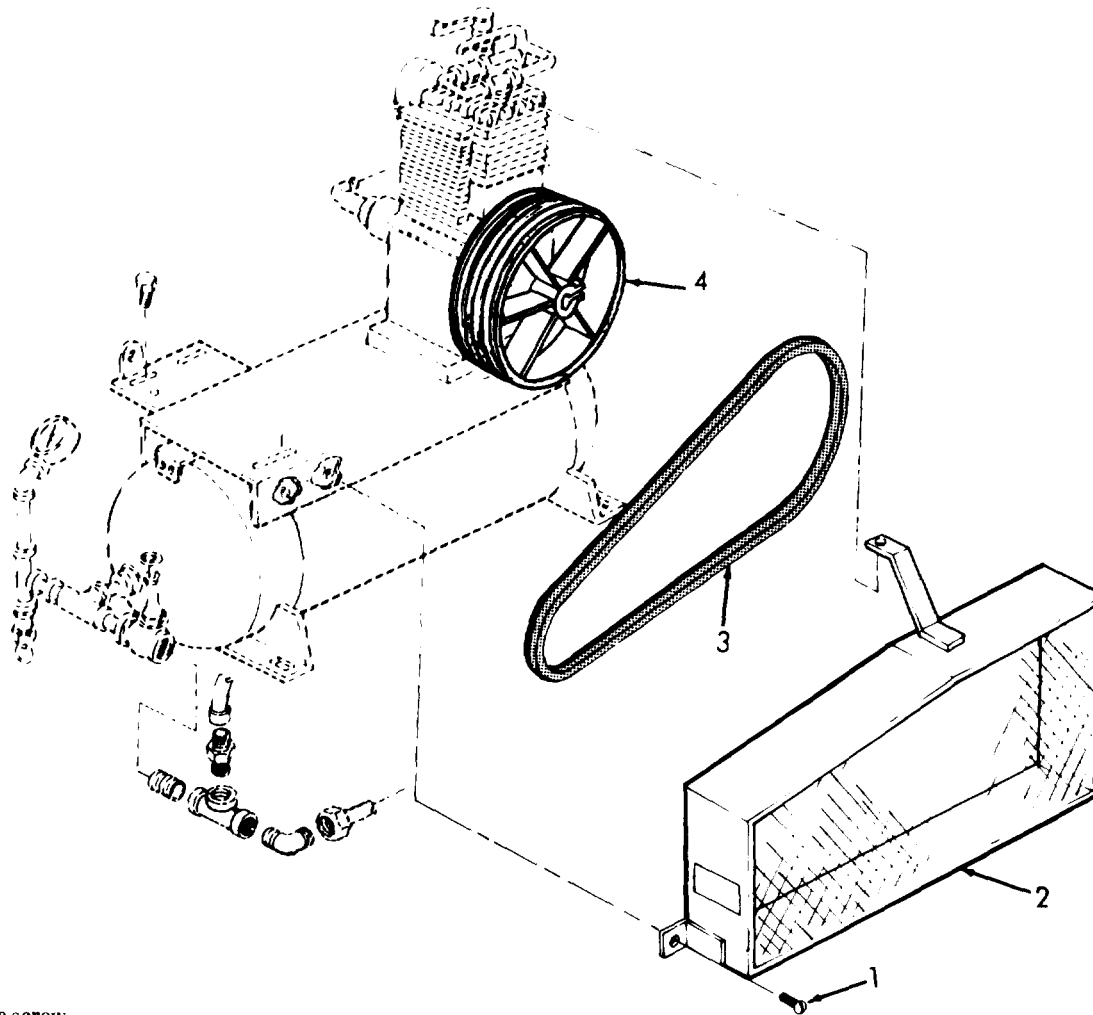

- 1 Machine screw
- 2 Drive belt guard
- 3 Compressor drive belt
- 4 Compressor flywheel

ME 4930-207-12/3-3

Figure 3-3. Compressor drive belt adjustment.

(2) Loosen engine mounting screws and move the engine toward or away from the air compressor to obtain $\frac{1}{2}$ to $\frac{3}{4}$ in. deflection at midway between the two pulleys.

(3) Tighten engine mounting screws.

(4) Install belt guard (2, fig. 3-3), and secure with two machine screws (1).

b. Belt Replacement (fig. 3-3).

(1) Remove belt guard and loosen engine mounting screws (a above).

(2) Remove old belt and install a new one.

(3) Adjust belt and tighten engine mounting screws (a above).

(4) Install belt guard (2) and secure with two screws (1).

3-18. Compressor Air Cleaner Service

a. Remove nut (1, fig. 3-4), screw (2), washer (3), screen (4), filter (5), screen (6) and baffle (7) from air cleaner body (8).

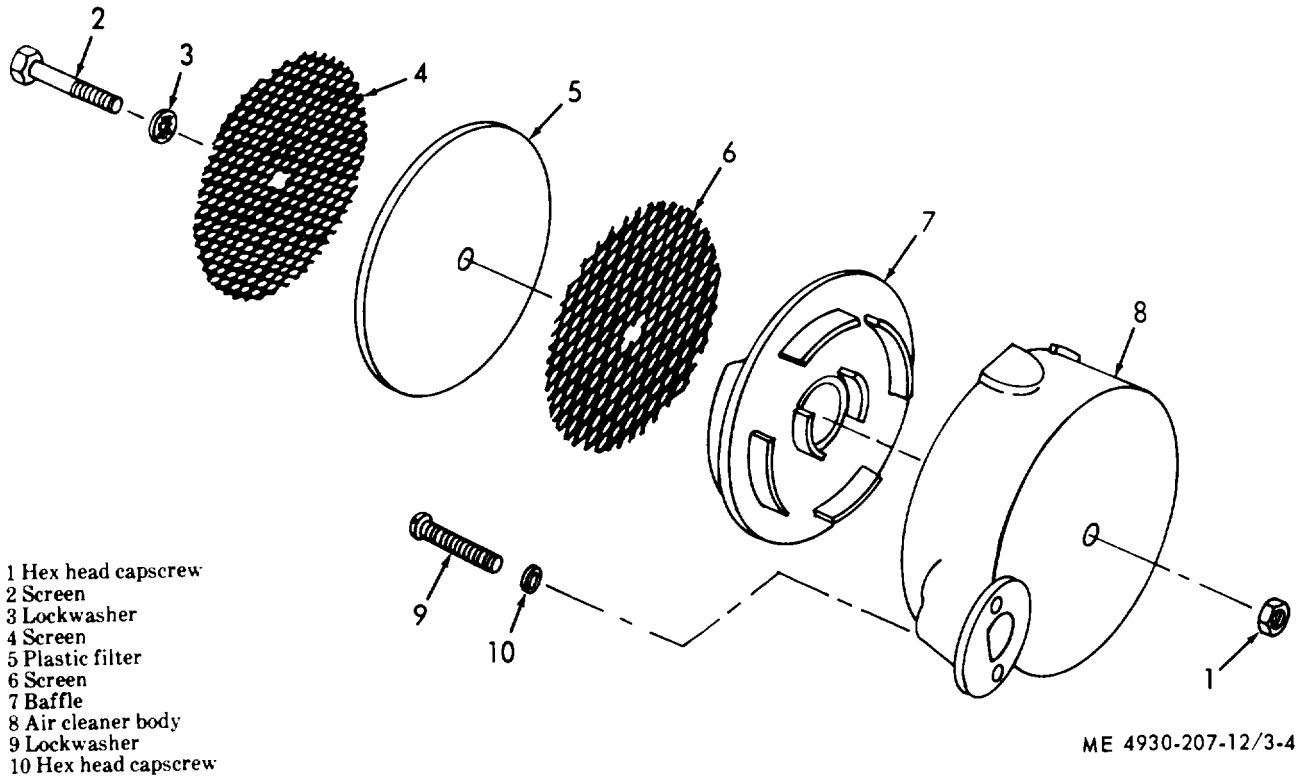

Figure 3-4. Compressor air cleaner service.

- b. Clean or replace plastic filter and screen as necessary.
- c. Install baffle (7), screen (6), plastic filter (5), screen (4) in air cleaner body (8) and secure with screws (1), washer (2) and nut (1).

3-19. Trailer Air Brake Filter and Reservoir
 Service the trailer brake air filter and reservoir as illustrated in figure 3-5.

RESERVOIR SERVICE: OPEN THE DRAINCOCK AND DRAIN ACCUMULATED MOISTURE FROM TANK.

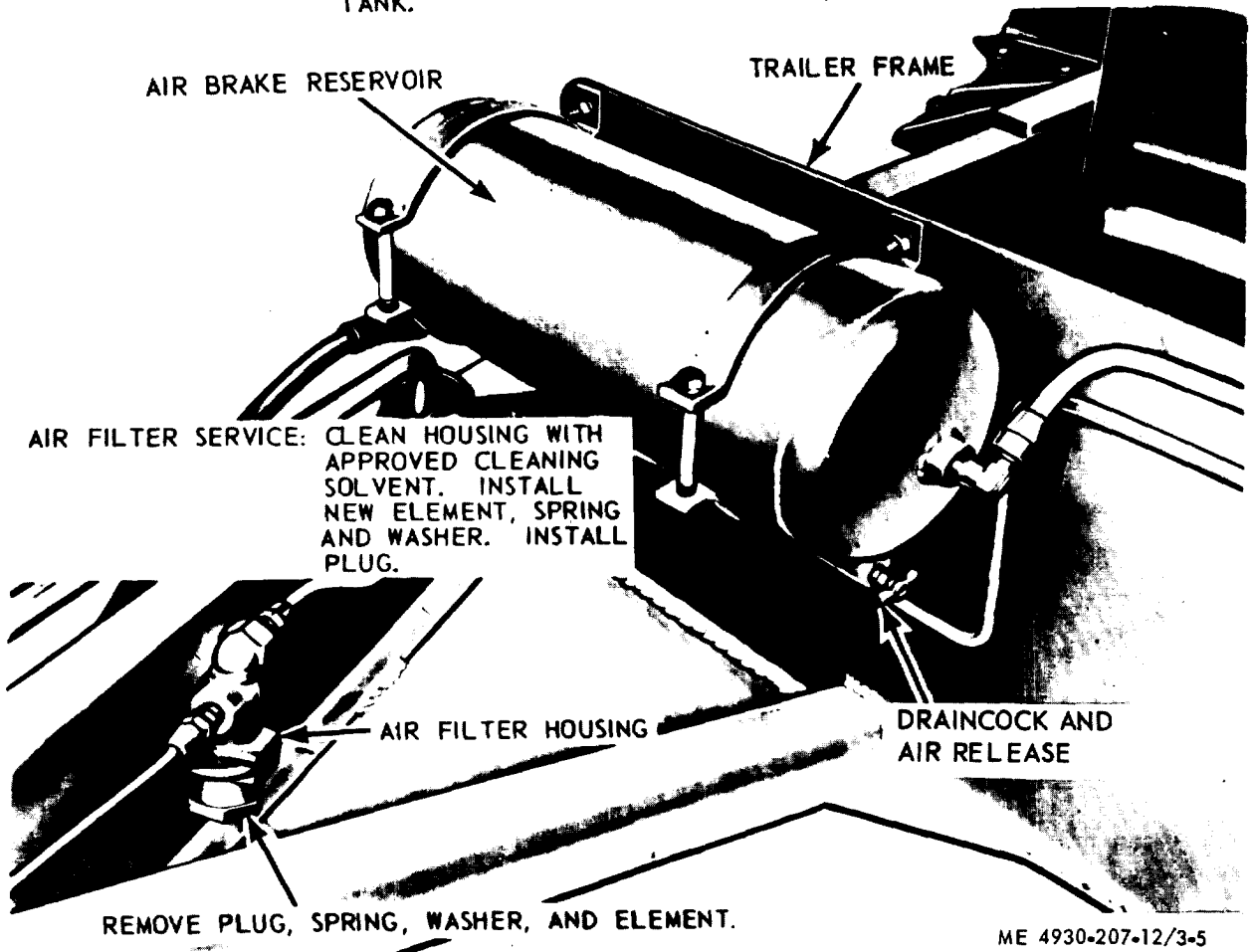

Figure 3-5. Trailer air brake filter and reservoir service.

CHAPTER 4
ORGANIZATIONAL MAINTENANCE INSTRUCTIONS

Section I. ORGANIZATIONAL PREVENTIVE MAINTENANCE SERVICES

4-1. General

Refer to paragraph 3-6 for the purpose of preventive maintenance checks and services.

4-2. Preventive Maintenance Services

Table 4-1 contains a tabulated list of preventive main-

tenance checks and services which must be performed by organizational maintenance personnel. Item numbers indicate the sequence of minimum inspection requirements and the interval column designates the required service intervals. A quarterly interval is equal to three calendar months or 250 hours of operation, whichever occurs first.

Table 4-1. Preventive Maintenance Checks and Services (Organizational)

Item number	Interval				Org.		Item to be inspected	Procedure	Reference
	Operator				M	Q			
	B	D	A	W					
1						x	Master cylinder and air brake chamber	Check for proper operation, leaks, loose fittings and secure mountings.	Para 4-43 and Para 4-44
2						x	Engine	Inspect engine for proper operation.	TM 5-2805-203-14
3						x	Carburetor and linkage	Check carburetor and linkage to see that they are in good condition, correctly installed and assembled. Check carburetor for leaks. Make sure choke valve opens fully when in released position.	TM 5-2805-203-14
4						x	Fuel pump and fuel lines	Inspect fuel pump and fuel lines for leaks. Check for secure mounting.	TM 5-2805-203-14
5						x	Fuel tank	Check fuel tank, lines and connections for leaks.	Para 4-20
6						x	Engine air cleaner	Check for secure mounting and loose connections.	TM 5-2805-203-14
7						x	Engine oil filter	Inspect oil filter for secure mounting. Inspect oil lines for leaks.	TM 5-2805-203-14
8							Compressor air cleaner	Inspect for secure mounting and loose connections.	Para 3-18
9						x	Lubricant pressure system	Check for lubricant or air leaks at all lines. Check swivel joints at hose reel inlets.	Paras 4-28 and 4-35
10						x	Lubricant tanks	Inspect lubricant tanks for cleanliness and leakage. Inspect tank cover to make sure it seals properly.	Para 4-31
11						x	Lubricant pumps	Inspect lubricant pumps for leakage and secure mounting. Inspect pump hoses for leaks or other damage.	Para 4-30 Para 4-34
12						x	Lubricant valves and meters	Inspect lubricant valves and meters for proper operation.	Para 4-32
13						x	Instrument panel	Inspect instrument panel for secure mounting. Inspect all gages and switches for proper operation.	Para 4-16

Section II. ORGANIZATIONAL MAINTENANCE TROUBLESHOOTING

4-3. General

Refer to paragraph 3-8 for a general description and purpose of troubleshooting the lubricating and servicing unit.

troubleshooting malfunctions, possible causes and corrective action to be taken. Refer to TM 5-2805-203-14 for military standard engine troubleshooting symptoms.

4-4. Troubleshooting Table

Table 4-2 lists the organizational maintenance

Table 4-2. Organizational Troubleshooting

Malfunction	Probable cause	Corrective action
1. Wheel hub throws grease.	<ul style="list-style-type: none"> a. Improper bearing lubricant. b. Loose or cracked hub cap. c. Damaged or worn grease seals. d. Defective gasket in hub. e. Other causes. 	<ul style="list-style-type: none"> a. Clean bearing thoroughly and lubricate in accordance with LO 5-4930-207-12. b. Tighten or replace hub cap (para 4-41). c. Replace grease seals (para 4-41). d. Replace gasket (para 4-41). e. Refer other causes to direct and general support maintenance personnel.
2. Wheel bearings overheat.	<ul style="list-style-type: none"> a. Lack of wheel bearing lubricant. b. Wheel bearings improperly adjusted. c. Other causes. 	<ul style="list-style-type: none"> a. Pack the wheel bearings (para 4-41). b. Adjust the wheel bearings (para 4-41). c. Refer other causes to direct and general support maintenance personnel.
3. Wheels wobble.	<ul style="list-style-type: none"> a. Wheel loose on hub. b. Wheel damaged or bent. c. Wheel bearings out of adjustment or defective. d. Other causes. 	<ul style="list-style-type: none"> a. Tighten wheel mounting nuts (para 4-40). b. Replace wheel (para 4-40). c. Adjust or replace bearings (para 4-41). d. Refer other causes to direct and general support maintenance personnel.
4. Trailer brakes inoperative.	<ul style="list-style-type: none"> a. Defective air brake chamber. b. Defective brake relay valve. c. Defective master cylinder. d. Air in hydraulic brake lines. e. Other causes. 	<ul style="list-style-type: none"> a. Repair or replace brake chamber (para 4-45). b. Replace relay valve (para 4-45). c. Replace master cylinder (para 4-44). d. Bleed the hydraulic brake lines (para 4-42). e. Refer other causes to direct and general support maintenance personnel.

Malfunction	Probable cause	Corrective action
5. Brakes grab.	<ul style="list-style-type: none"> a Brakes improperly adjusted. b. Defective brake relay valve. c. Other causes. 	<ul style="list-style-type: none"> a Adjust brakes (para4-42). b. Replace brake valve (para 4-46). c. Refer other causes to direct and general support maintenance personnel.
6. Brakes overbeat.	<ul style="list-style-type: none"> a Brake shoe spring loose or broken b. Brakes improperly adjusted. c. Other causes. 	<ul style="list-style-type: none"> a Replace brake spring (para 4-43). b. Adjust brakes (para 4-42). c. Refer other causes to direct and general support maintenance personnel.
7. Compressor noisy.	<ul style="list-style-type: none"> a. Loose flywheel or engine pulley. b. Worn V-belts. c. Other causes. 	<ul style="list-style-type: none"> a. Tighten pulleys (para 4-23). b. Replace V-belts (para 4-23). c. Refer other causes to direct and general support maintenance personnel.
8. Compressor V-belts worn excessively	<ul style="list-style-type: none"> a. Drive pulleys out of alinement. b. V-belts too loose or tight. c. Oil or grease on V-belts. d. Other causes. 	<ul style="list-style-type: none"> a. Aline pulleys (para 4-23). b. Adjust V-belts (para 3-17). c. Replace V-belts (para 3-17). d. Refer other causes to direct and general support maintenance personnel.
9. Lubricant delivery is faulty.	<ul style="list-style-type: none"> a. Dirty or sticking control valve. b. Leak in lubricant lines. c. Other causes. 	<ul style="list-style-type: none"> a. Clean control valve (para 4-32). b. Tighten all hose couplings and replace defective hoses (para 4-33). c. Refer other causes to direct and general support maintenance personnel.
10. Lubricant pump fails to operate.	<ul style="list-style-type: none"> a Faulty connections in grease line. b. Inadequate supply of air. c. Other causes. 	<ul style="list-style-type: none"> a. Inspect line for leaks in hose, swivel connectors, control handle and pipeline. b. Inspect air connections. Repair and replace parts as required (para 4-29). c. Refer other causes to direct and general support maintenance personnel.

(4) Attach a suitable lifting device to the four lifting handles (10) and lift the enclosure assembly over the unit frame.

b. Disassembly. Disassemble the enclosure housing in numerical sequence as illustrated in figure 4-1.

c. Reassembly. Reassemble the enclosure housing in the reverse of numerical sequence as illustrated in figure 4-1.

d. Installation.

(1) Attach a suitable lifting device to the four lifting handles (10, fig. 4-1) and install the enclosure assembly over the lubricator frame.

(2) Install four lifting ring washers (2) and lifting rings (1) and secure the enclosure assembly to the

lubricator frame.

(3) Connect the fuel filler cap chain and the static wire at the fuel tank filler housing (fig. 1-2).

4-7. Battery and Battery Drawer

a. Removal. Remove the battery and battery box in numerical sequence as illustrated in figure 2-3.

b. Installation. Install the battery box and batteries in the reverse of numerical sequence as illustrated in figure 2-3.

4-8. Tool Box and Accessory Drawers

a. Removal. Remove the tool box and accessory drawers in numerical sequence as illustrated in figure 4-2.

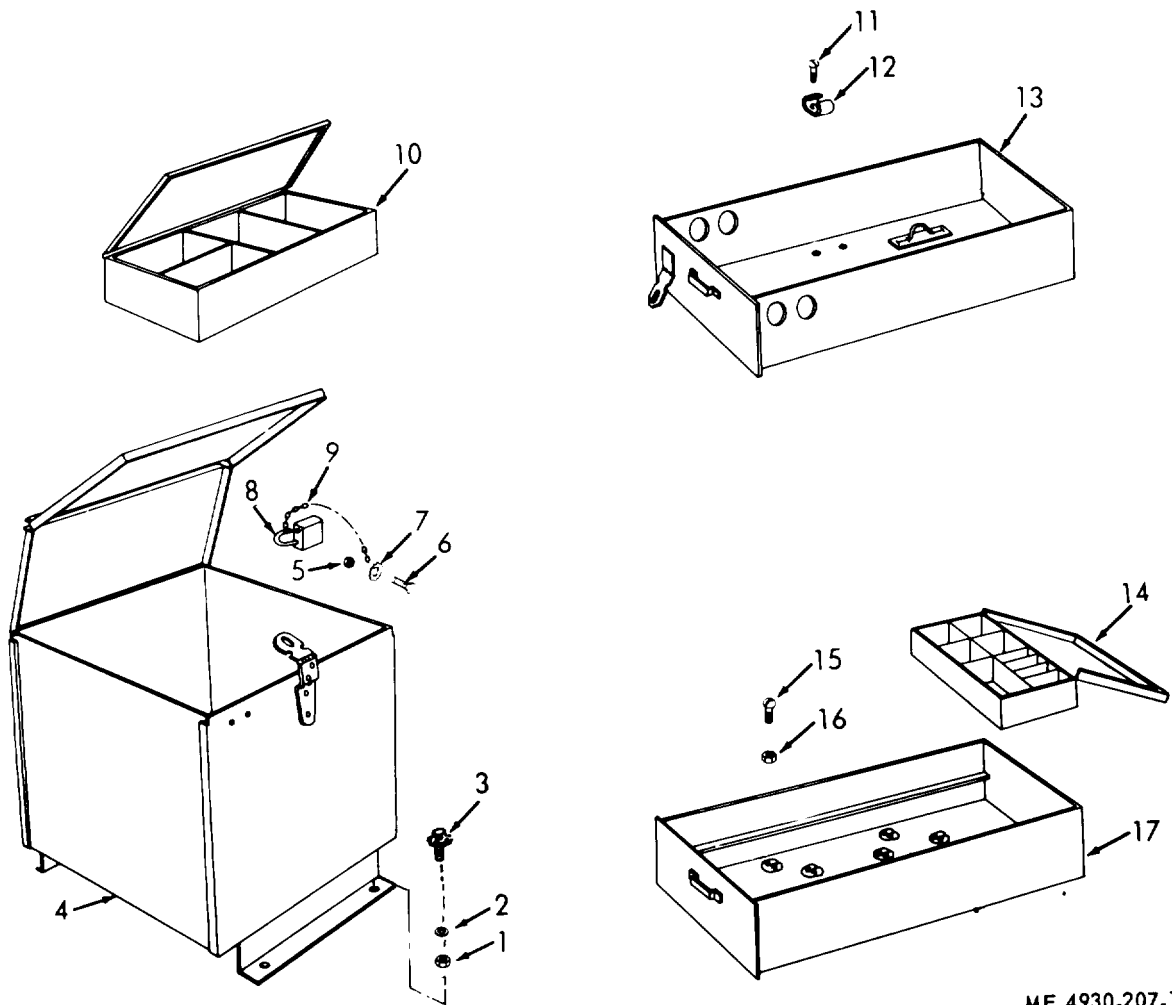

ME 4930-207-12/4-2

- | | |
|-----------------------------|---------------------------|
| 1 Plain hex nut | 10 Upper accessory tray |
| 2 Lockwasher | 11 Machine screw |
| 3 Hex head capscrew | 12 Drawer clamp |
| 4 Tool box | 13 Upper accessory drawer |
| 5 Plain hex nut | 14 Lower accessory tray |
| 6 Machine screw | 15 Machine screw |
| 7 External tooth lockwasher | 16 Drawer clamp |
| 8 Padlock | 17 Lower accessory drawer |
| 9 Padlock chain | |

Figure 4-2. *Tool box and accessory drawer, removal and installation.*

b. *Installation.* Install the tool box and accessory drawers in the reverse of numerical sequence as il-

lustrated in figure 4-2.

Section IV. ELECTRICAL SYSTEM

4-9. General

a. The lubricator electrical system consists of a 24-volt generator, voltage regulator, starting motor, instrument panel, trouble light and two batteries.

b. The trailer electrical system consists of clear-ante lights, taillights, blackout stoplight and wiring harness.

- 1 Hex head capscrew
- 2 Machine screw
- 3 Case cover
- 4 Cover disc
- 5 Case assembly
- 6 Fibre shield
- 7 Machine screw
- 8 Commutator block
- 9 Outer ring
- 10 Inner ring
- 11 Thrust washer
- 12 Insulator plug
- 13 Solid rivet
- 14 Solid rivet

- 15 Cable reel contact assembly
- 16 Solid rivet
- 17 Brush holder
- 18 Insulator plug
- 19 Solid rivet
- 20 Solid rivet
- 21 Solid rivet
- 22 Machine screw
- 23 Brush holder
- 24 Jam nut
- 25 Stop pawl
- 26 Mounting bracket
- 27 Reel lid
- 28 Spring retaining rivet
- 29 Return spring
- 30 Spring bushing
- 31 Ratchet plate
- 32 Reel return ratchet
- 33 Pawl pivot stud
- 34 Helical spring
- 35 Stop pawl
- 36 Upper pulley

- 37 Main shaft
- 38 Brush block assembly
- 39 Brush plug
- 40 Reel pulley assembly
- 41 Rubber tube
- 42 Release ring
- 43 Wiring harness
- 44 Wood screw
- 45 Switch plate
- 46 Light switch
- 47 Incandescent lamp
- 48 Electrical jumper lead
- 49 Trouble light body
- 50 Power lead
- 51 Ground lead
- 52 Cable assembly
- 53 Wire assembly

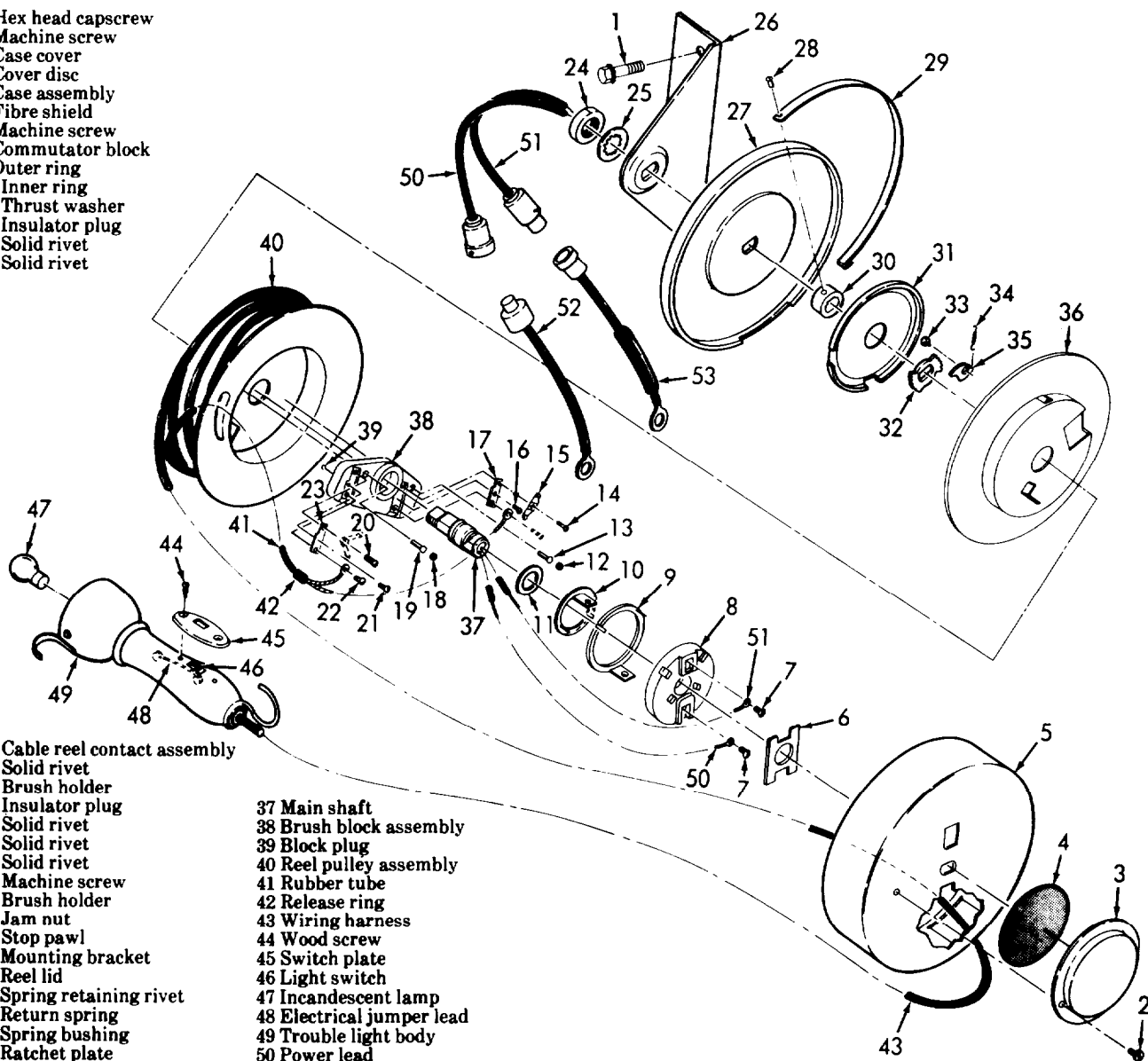

ME 4930-207-12/4-3

Figure 4-3. Trouble light, *disassembly and reassembly.*

c. Refer to TM 5-2805-203-14 for maintenance on the basic engine electrical components.

4-10. Trouble light

a. *Removal.*

(1) Disconnect power lead (50, fig. 4-3), cable (52) and ground lead (51) from wire assembly (53).

(2) Remove screws (1) securing mounting bracket (26) to the unit frame and remove the trouble light assembly.

b. Disassembly. Disassemble the trouble light assembly in numerical sequence as illustrated in figure 4-3.

c. Inspection and Repair.

(1) Inspect all electrical leads for damaged insulation.

(2) Inspect remaining parts for cracks, breaks, or other damage.

(3) Repair by replacement of defective parts.

d. Reassembly. Reassemble the trouble light assembly in the reverse of numerical sequence as illustrated in figure 4-3.

e. Installation.

(1) Position the trouble light assembly on the unit frame and secure bracket (26) with screws (1).

(2) Connect the power lead (50) and cable assembly (52) and ground lead (51) to wire assembly (53).

4-11. Generator and Voltage Regulator

a. Removal.

(1) Tag and disconnect all electrical leads at the voltage regulator.

(2) Refer to figure 3-2 and remove the generator drive belt guard.

(3) Remove the generator and voltage regulator assembly in numerical sequence as illustrated in figure 4-4.

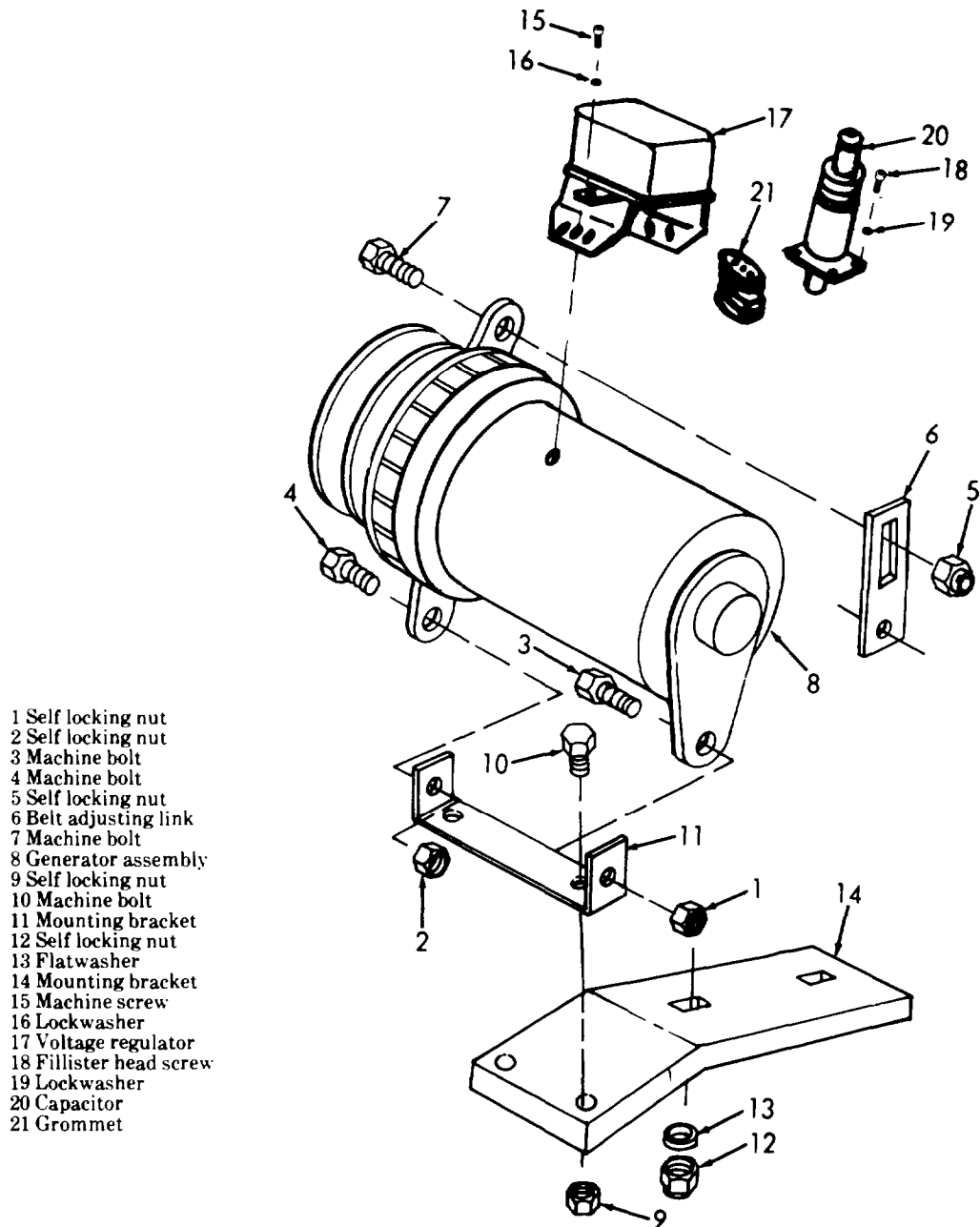

- 1 Self locking nut
- 2 Self locking nut
- 3 Machine bolt
- 4 Machine bolt
- 5 Self locking nut
- 6 Belt adjusting link
- 7 Machine bolt
- 8 Generator assembly
- 9 Self locking nut
- 10 Machine bolt
- 11 Mounting bracket
- 12 Self locking nut
- 13 Flat washer
- 14 Mounting bracket
- 15 Machine screw
- 16 Lockwasher
- 17 Voltage regulator
- 18 Fillister head screw
- 19 Lockwasher
- 20 Capacitor
- 21 Grommet

Figure 4-4. Generator and voltage regulator, removal and installation.

ME 4930-207-12/4-4

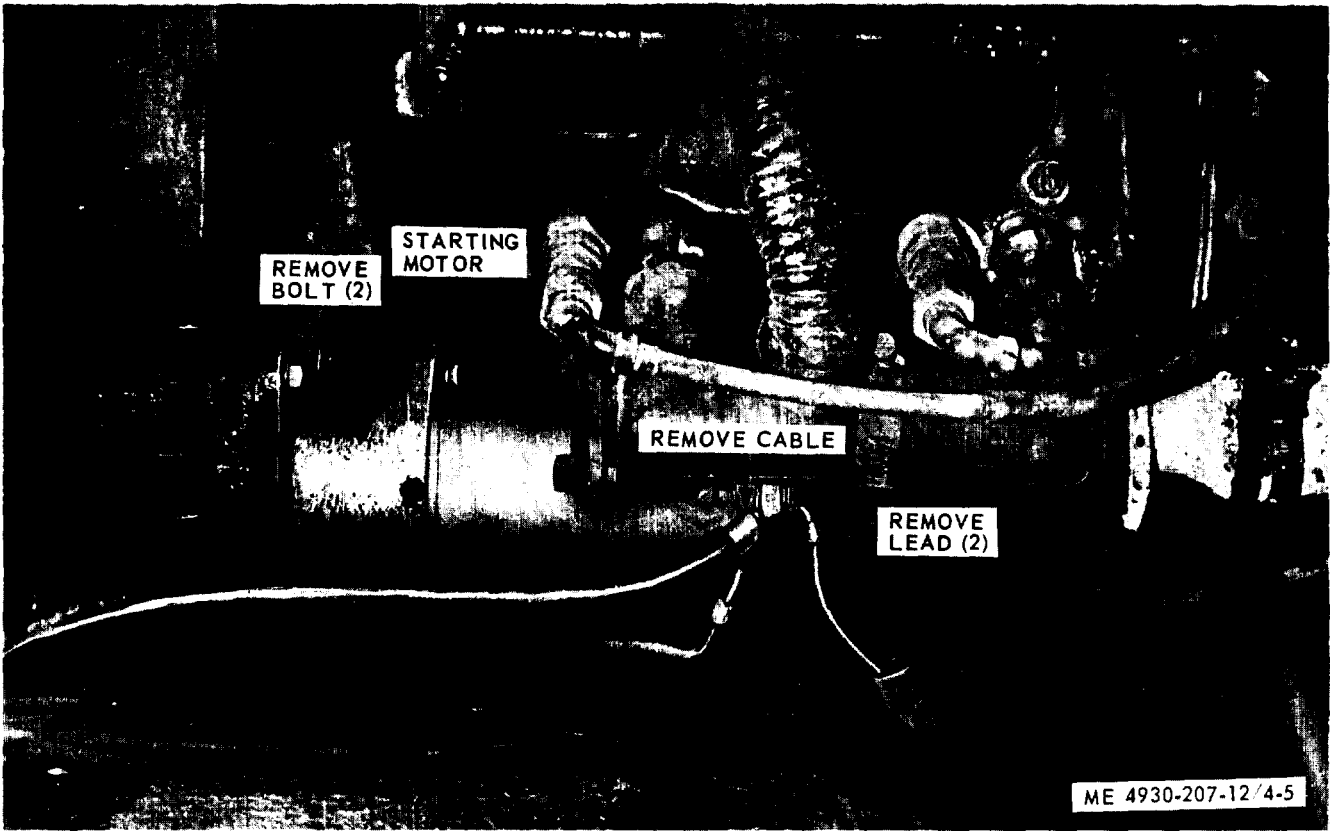

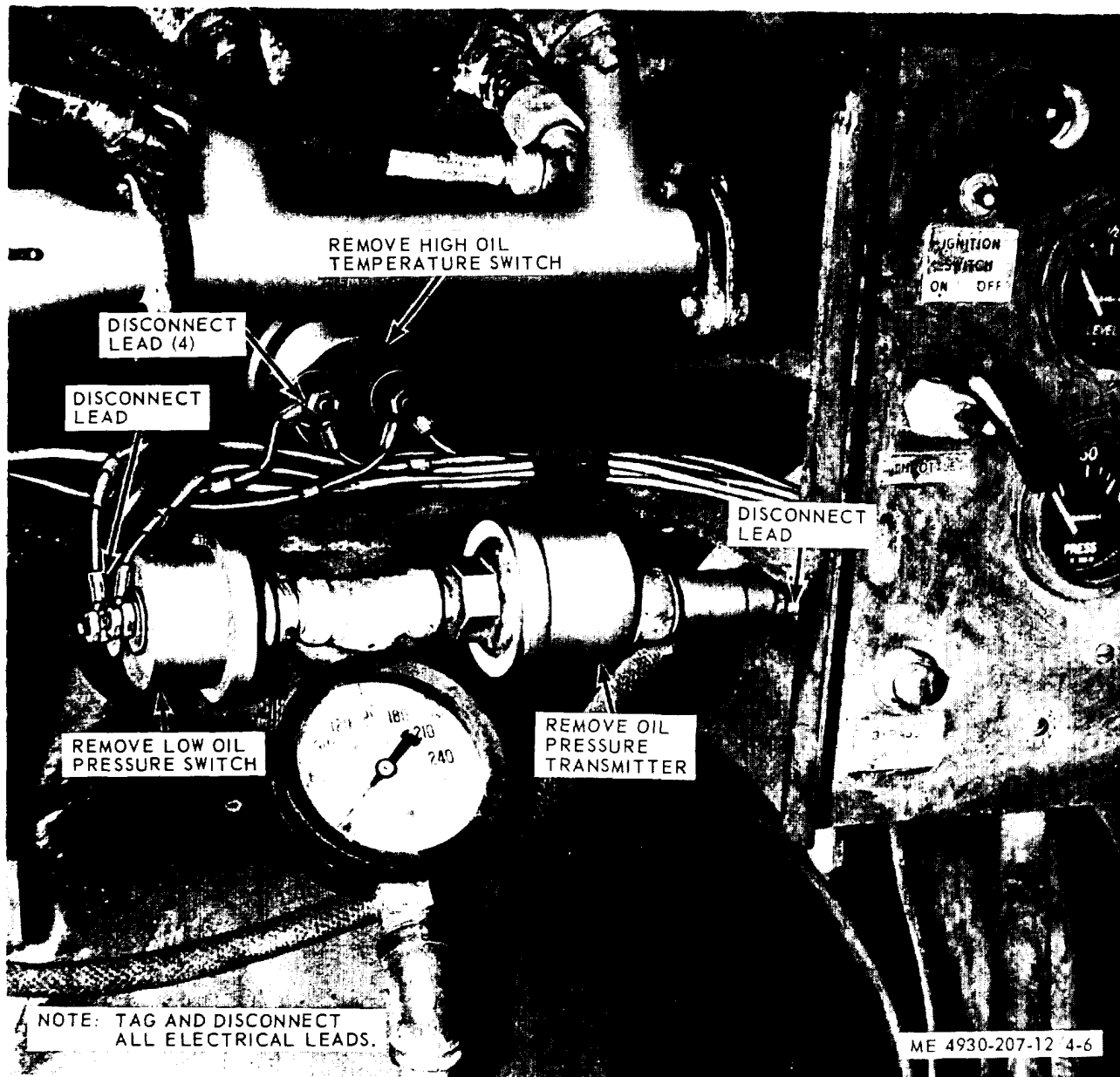

Figure 4-6. Oil pressure transmitter and oil pressure switches, removal and installation.

4-14. High Oil Temperature Switch

Refer to figure 4-6 for removal and installation of the high engine oil temperature switch.

4-15. Oil Pressure Transmitter

Refer to figure 4-6 for removal and installation of the engine oil pressure transmitter.

4-16. Instrument Panel, Gages and Switches

a. Removal.

(1) Tag and disconnect electrical component to be removed.

(2) Refer to figure 4-7 and remove attaching hardware as necessary for removal of the instrument panel, gages, switches and panel lights.

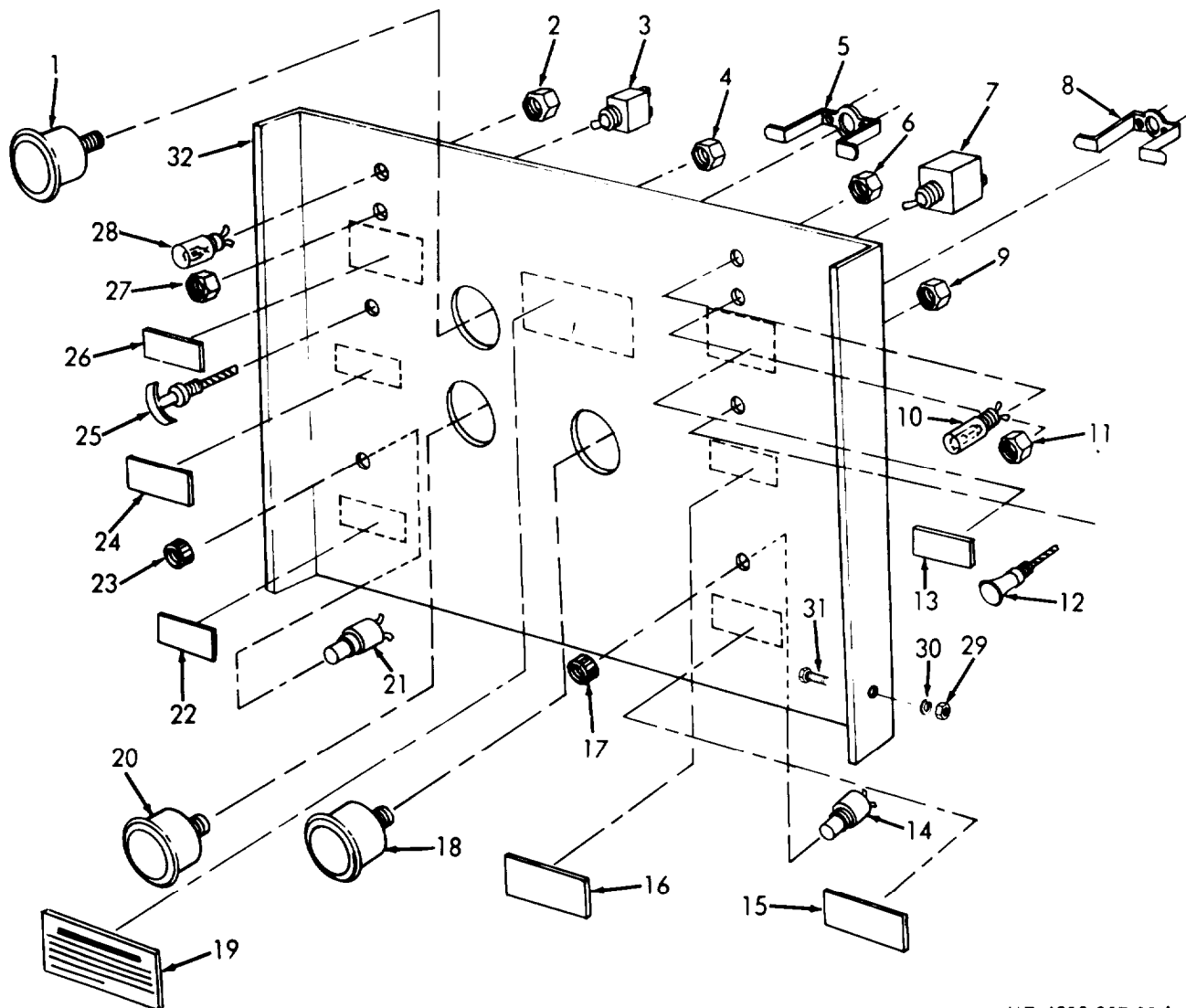

ME 4930-207-12/4-7

- | | |
|---------------------------|---------------------------|
| 1 Fuel indicator | 17 Knurled nut |
| 2 Plain hex nut | 18 Ammeter |
| 3 Ignition toggle switch | 19 Instruction plate |
| 4 Plain hex nut | 20 Oil pressure indicator |
| 5 Indicator bracket | 21 By-pass switch |
| 6 Plain hex nut | 22 Start switch plate |
| 7 Toggle light switch | 23 Knurled nut |
| 8 Indicator bracket | 24 Throttle plate |
| 9 Plain hex nut | 25 Throttle control |
| 10 Panel light | 26 Ignition switch plate |
| 11 Plain hex nut | 27 Plain hex nut |
| 12 Choke control assembly | 28 Panel light |
| 13 Light switch plate | 29 Hex nut |
| 14 Push-start switch | 30 Lockwasher |
| 15 Choke plate | 31 Hex head capscrew |
| 16 By-pass switch plate | 32 Instrument panel |

Figure 4-7. Gages, control panel, gages, and switches, removal and installation.

b. Inspection and Repair.

- (1) Inspect all electrical leads for frayed insulation or defective terminals.
- (2) Inspect all gages for cracked or broken glass.
- (3) Inspect choke and throttle controls for free movement.

- (4) Repair or replace defective wiring. Replace all other defective components.

c. Installation.

- (1) Refer to figure 4-7 for installation of the instrument panel, gages, switches and panel lights.

(2) Remove identification tags from electrical leads.

a. Removal. Remove the trailer clearance lights and lamps as illustrated in figure 4-8.

4-17. Trailer Clearance Lights and Lamps



ME 4930-207-12/4-8

Figure 4-8. Trailer clearance lights and lamps, removal and installation.

b. Disassembly. Disassemble the trailer clearance lights in numerical sequence as illustrated in figure 4-9.

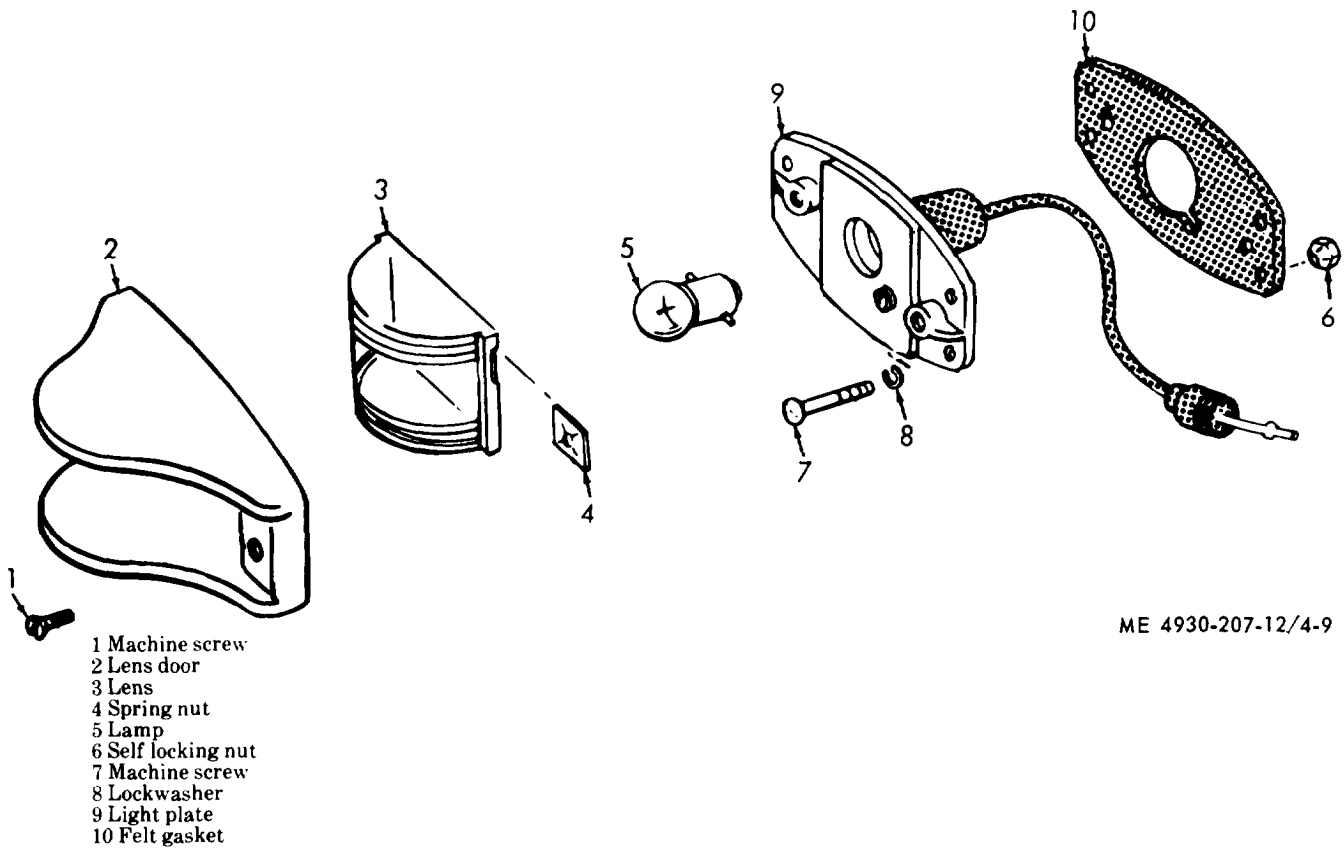

Figure 4-9. Trailer clearance lights, disassembly and reassembly.

c. *Reassembly.* Reassemble the trailer clearance lights in the reverse of numerical sequence as illustrated in figure 4-9.

d. *Installation.* Install the clearance lights and lamps as illustrated in figure 4-8.

4-18. Taillights, Lamps and Wiring Harness

a. *Removal.* Remove the trailer reflectors, blackout stoplight, taillights, lamps and wiring harness as illustrated in figure 4-10.

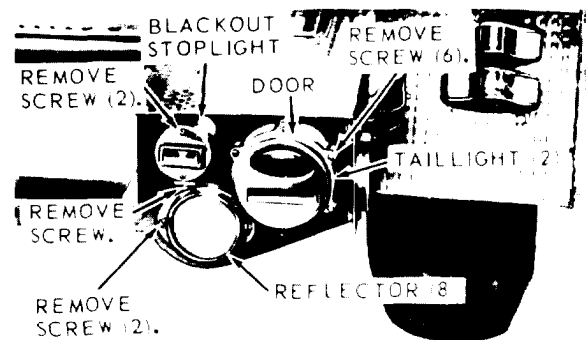

NOTE: TAG AND DISCONNECT ELECTRICAL LEADS AS NECESSARY.

REMOVE OTHER REFLECTORS AND LIGHTS IN A SIMILAR MANNER.

LAMP REPLACEMENT:

- STEP 1. REMOVE DOOR SCREWS.
- STEP 2. REMOVE DOOR, GASKET, AND DARK OR BURNED OUT LAMPS
- STEP 3. REPLACE LAMPS, DOOR, AND GASKET, AND SECURE WITH MOUNTING SCREWS.

ME 4930-207-12/4-10(1)

Figure 4-10. Reflectors, blackout-stoplight, taillights, lamps and wiring harness, removal and installation (sheet 1 of 2).

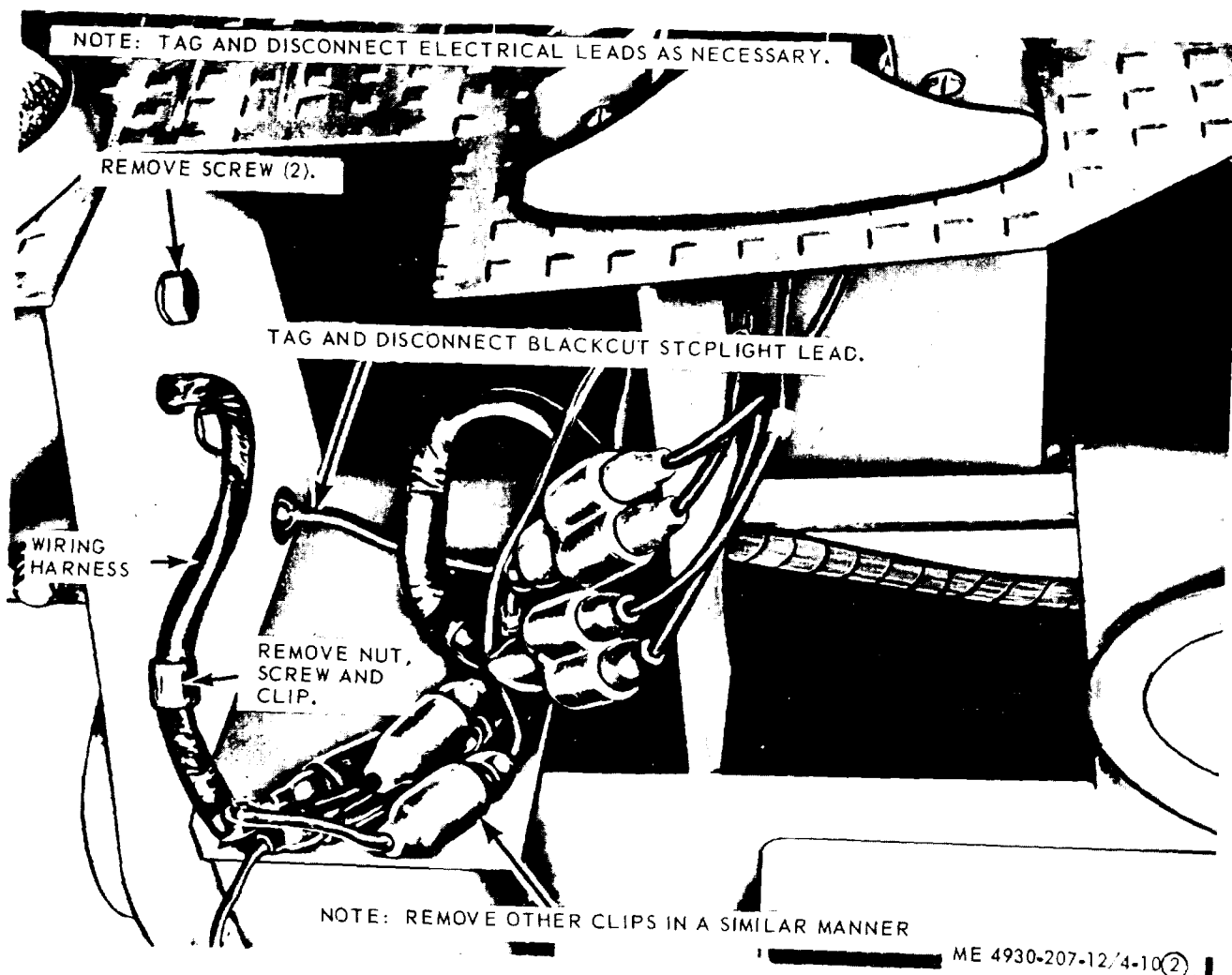
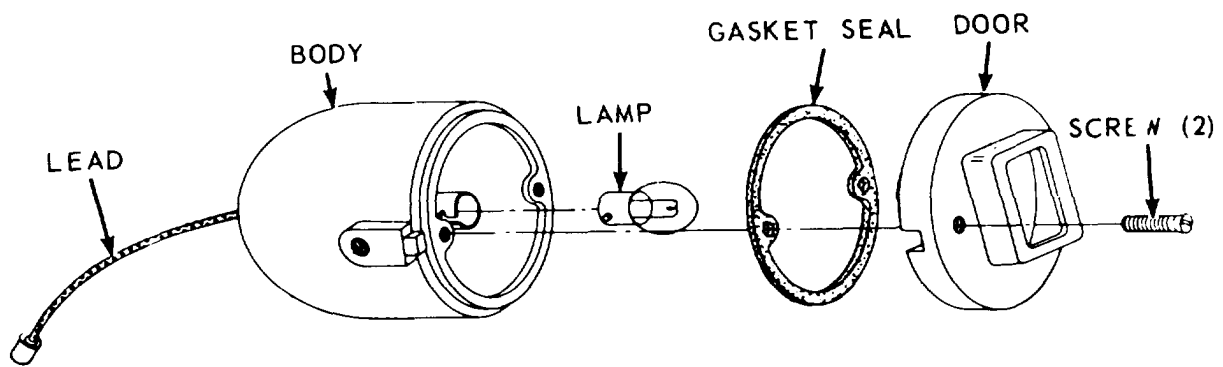

Figure 4-10. Reflectors, blackout-stoplight, taillights, lamps and wiring harness, removal and installation (sheet 2 of 2).

b. Disassembly.

- (1) Disassemble the taillight and blackout stoplight as illustrated in figure 4-11.



A

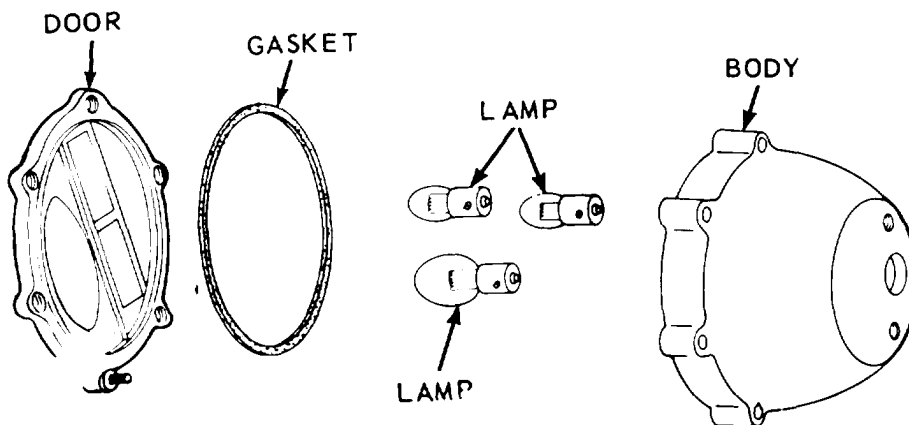

B

ME 4930-207-12/4-11

Figure 4-11. Taillight and blacknut-stopligh, disassemble and reassembly.

(2) Remove and disassemble the intervehicular receptacle in numerical sequence as illustrated in figure 4-12.

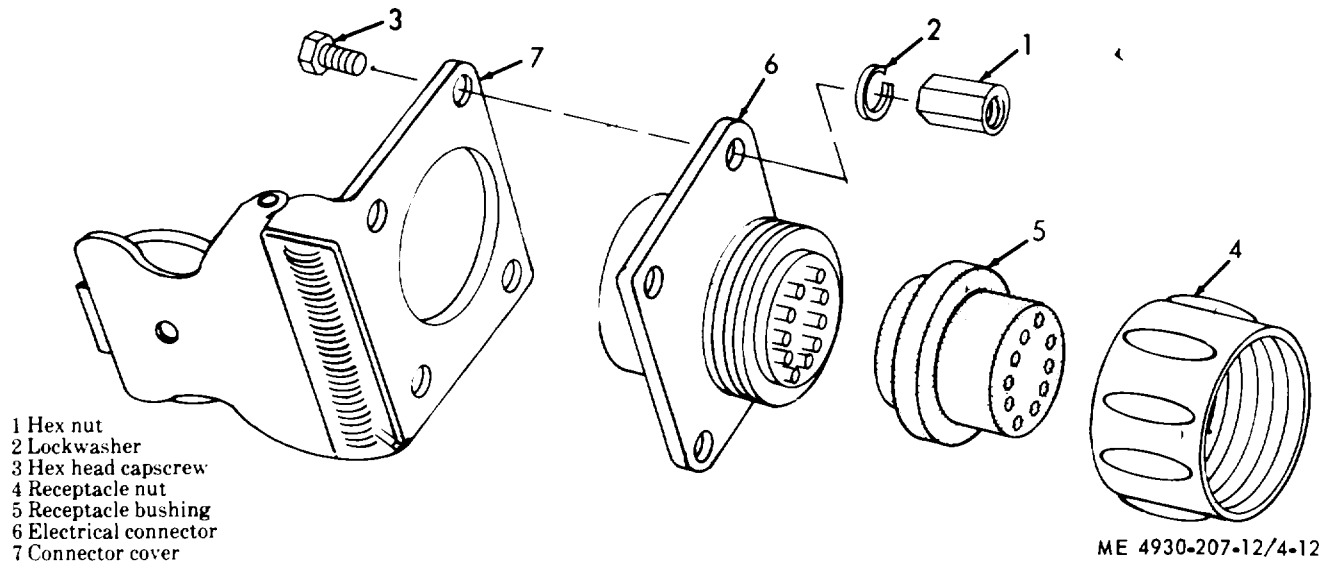

Figure 4-12. Intervehicular receptacle, disassembly and reassembly.

c. Reassembly.

(1) Reassemble the blackout-stoplight and tail-light as illustrated in figure 4-11.

(2) Reassemble and install the intervehicular receptacle in the reverse of numerical sequence as

illustrated in figure 4-12.

d. Installation. Install the trailer reflectors, blackout-stoplight, taillights, lamps and wiring harness as illustrated in figure 4-10.

Section V. FUEL AND EXHAUST SYSTEM

4-19. General

a. Fuel System. The lubricating unit is equipped with a positive-feed, pressure type fuel system. The fuel system consists of a fuel filter, fuel tank, fuel pump, carburetor, air cleaner, governor and governor controls. Refer to TM 5-2805-203-14 for maintenance on the fuel pump, carburetor, air cleaner, governor and governor controls.

b. Exhaust System. The lubricating unit is

equipped with an exhaust diverter, which serves as a muffler, connected directly to the engine exhaust system. This diverter is used to direct exhaust gases into a heat reservoir below the lubricant tanks, for cold weather operation, or to the atmosphere.

4-20. Fuel Tank, Filter and Lines

a. Removal.

(1) Open the fuel shut-off cock (29, fig. 4-13) and drain the fuel tank (27).

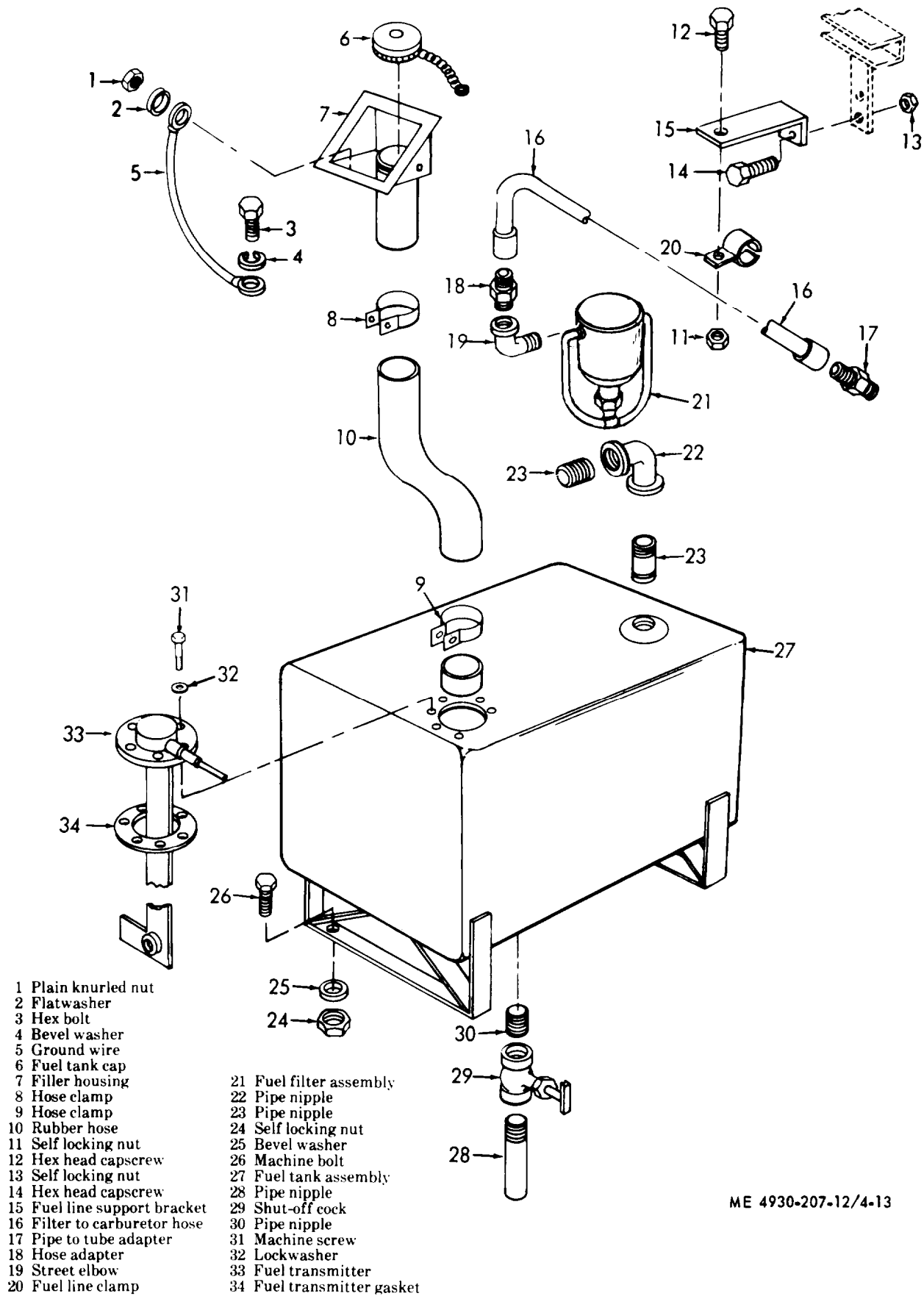

ME 4930-207-12/4-13

Figure 4-13. Fuel tank, removal and installation.

(2) Disconnect the fuel transmitter (33) at the fuel tank (27).

(3) Remove the fuel tank, fuel filter and lines in numerical sequence as illustrated in figure 4-13.

b. Installation.

(1) Install the fuel tank, fuel lines and fuel filter in the reverse of numerical sequence as illustrated in figure 4-13.

(2) Connect the fuel transmitter (3) at the fuel

tank (27).

(3) Service the fuel tank.

4-21. Exhaust Diverter Valve

a. Removal.

(1) Loosen two clamps on each of the three exhaust hoses and remove the hoses.

(2) Remove the exhaust diverter valve in numerical sequence as illustrated in figure 4-14.

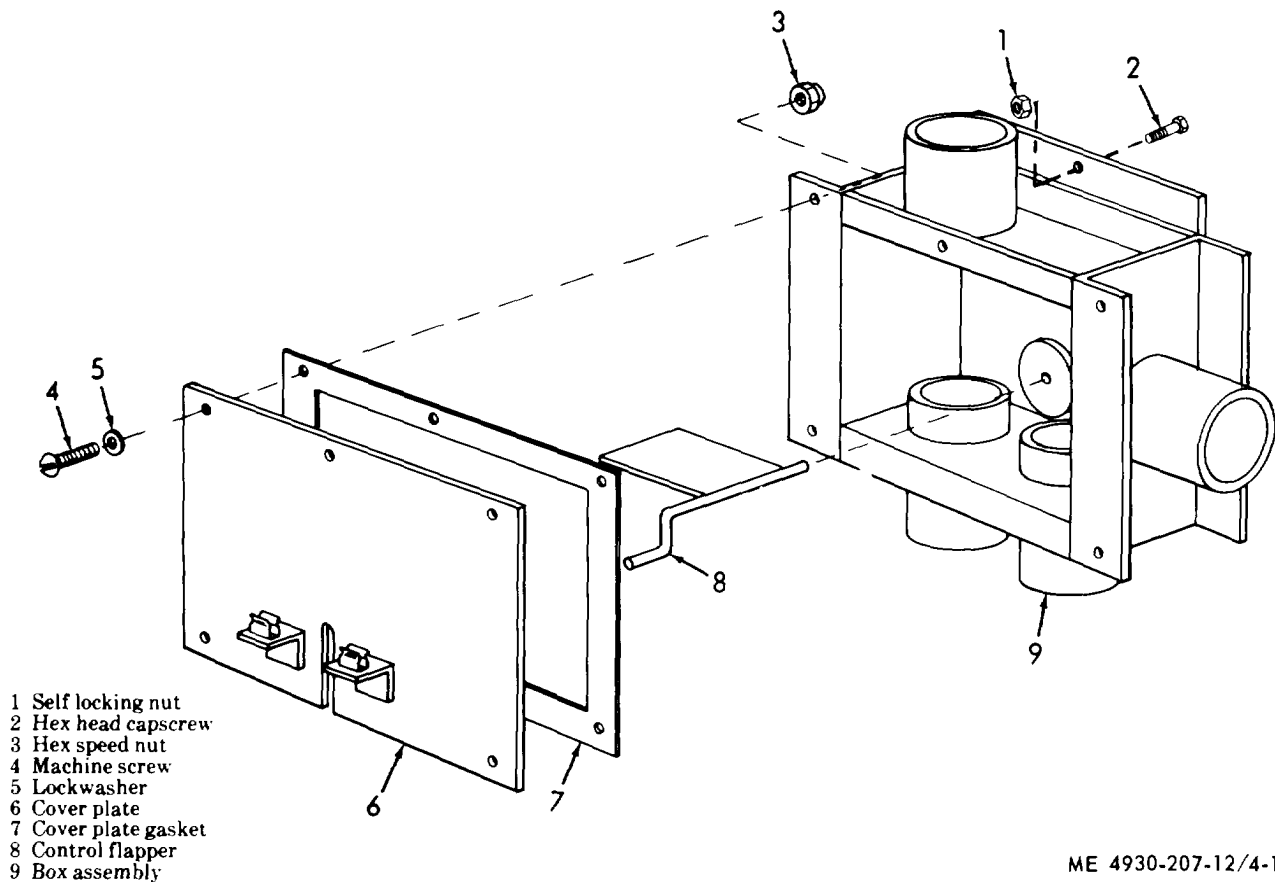

ME 4930-207-12/4-14

Figure 4-14. Exhaust diverter valve, removal and installation.

b. Inspection and Repair.

(1) Inspect the exhaust hoses for leakage and rust.

(2) Inspect exhaust diverter valve for cracks, breaks or other damage.

(3) Discard and replace cover plate gaskets. Replace all other defective parts.

c. Installation.

(1) Install the exhaust diverter valve in the reverse of numerical sequence as illustrated in figure 4-14.

(2) Install the three exhaust hoses and secure each hose with two clamps.

Section VI. COMPRESSOR ASSEMBLY AND AIR LINES

4-22. General

The lubricating unit is equipped with a two stage 23 cfm air compressor. The twin-cylinder construction gives a higher discharge pressure with less consumption of power. The larger cylinder is the low pressure cylinder and the smaller is the high pressure cylinder. The low pressure, or first stage, exhausts air into the intercooler which cools the air before it enters under 45 psi pressure into the high pressure cylinder. The compressor has a splash-type lubrication system. The compressor is equipped with an automatic pressure control which unloads when the air reservoir pressure reaches 175 psi, and allows compression to

resume when pressure drops to 150 psi. A centrifugal unloader automatically opens a valve releasing pressure from cylinders, and aftercooler each time the compressor stops. Air is exhausted outside the crankcase where moisture cannot contaminate the lubricant.

4-23. Air Compressor Drive Pulley

a. Removal.

(1) Remove the compressor drive belt guard and drive belt (para 3-17).

(2) Remove the compressor drive pulley as illustrated in figure 4-15.

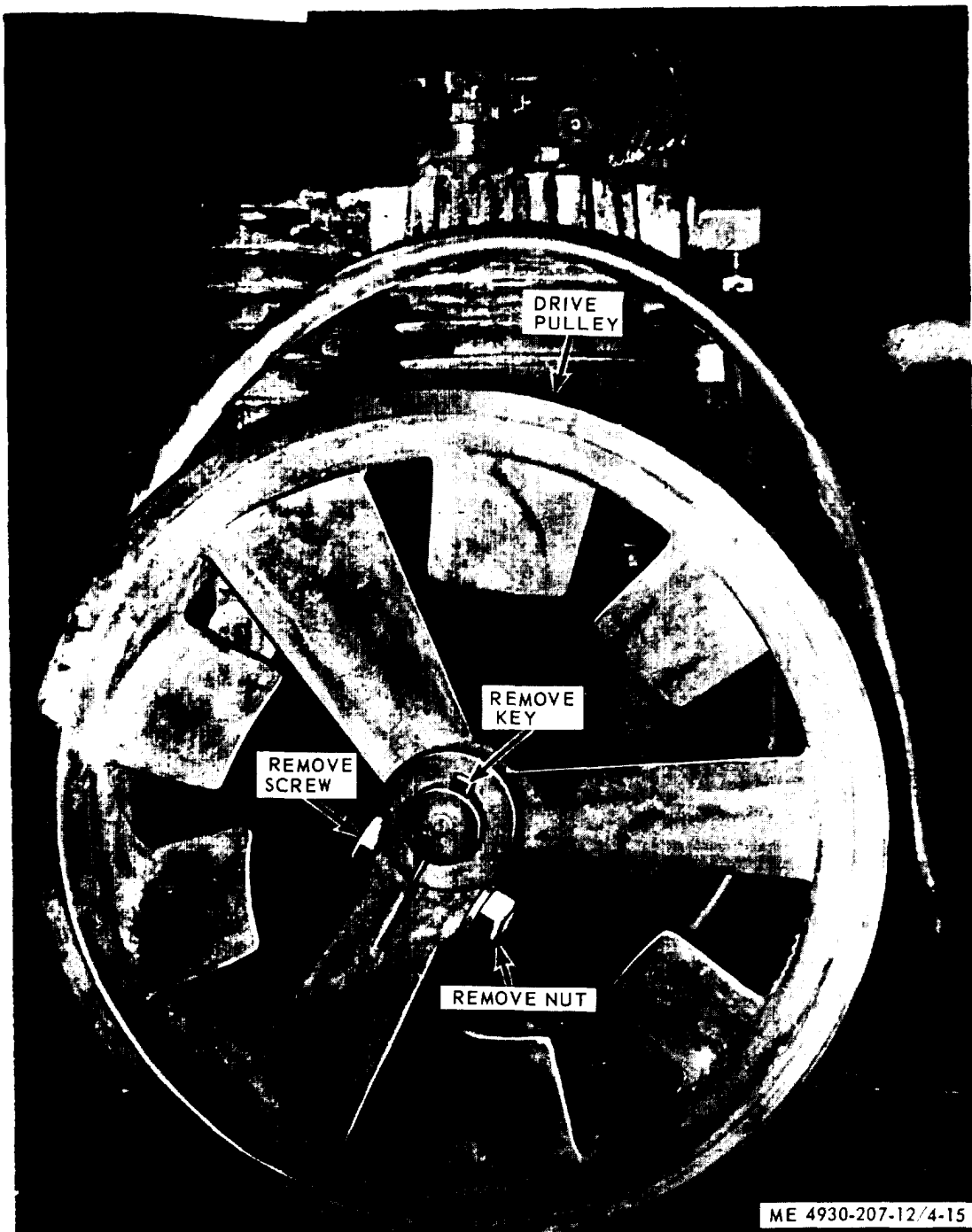

Figure 4-15. Compressor drive pulley, removal and installation

b. Installation

(1) Install the compressor drive pulley as illustrated in figure 4-15.

(2) Install and adjust the compressor drive belt (para 3-17).

(1) Open air receiver drain valve (fig release all air pressure from air receiver.

(2) Remove the compressor hoses, lines and fittings as illustrated in figure 4-16.

4-24. Air Hoses, lines and Fittings

a. Removal.

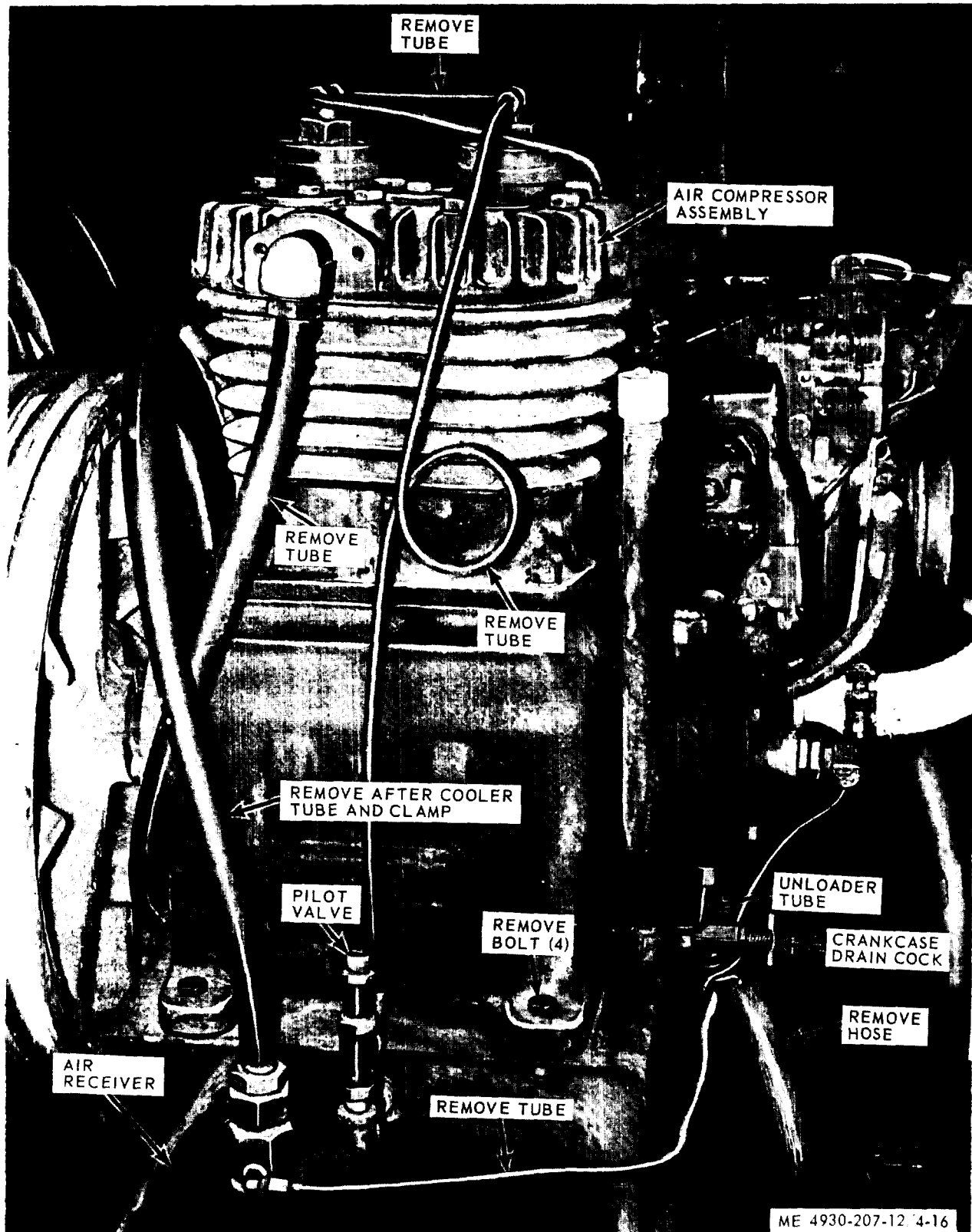
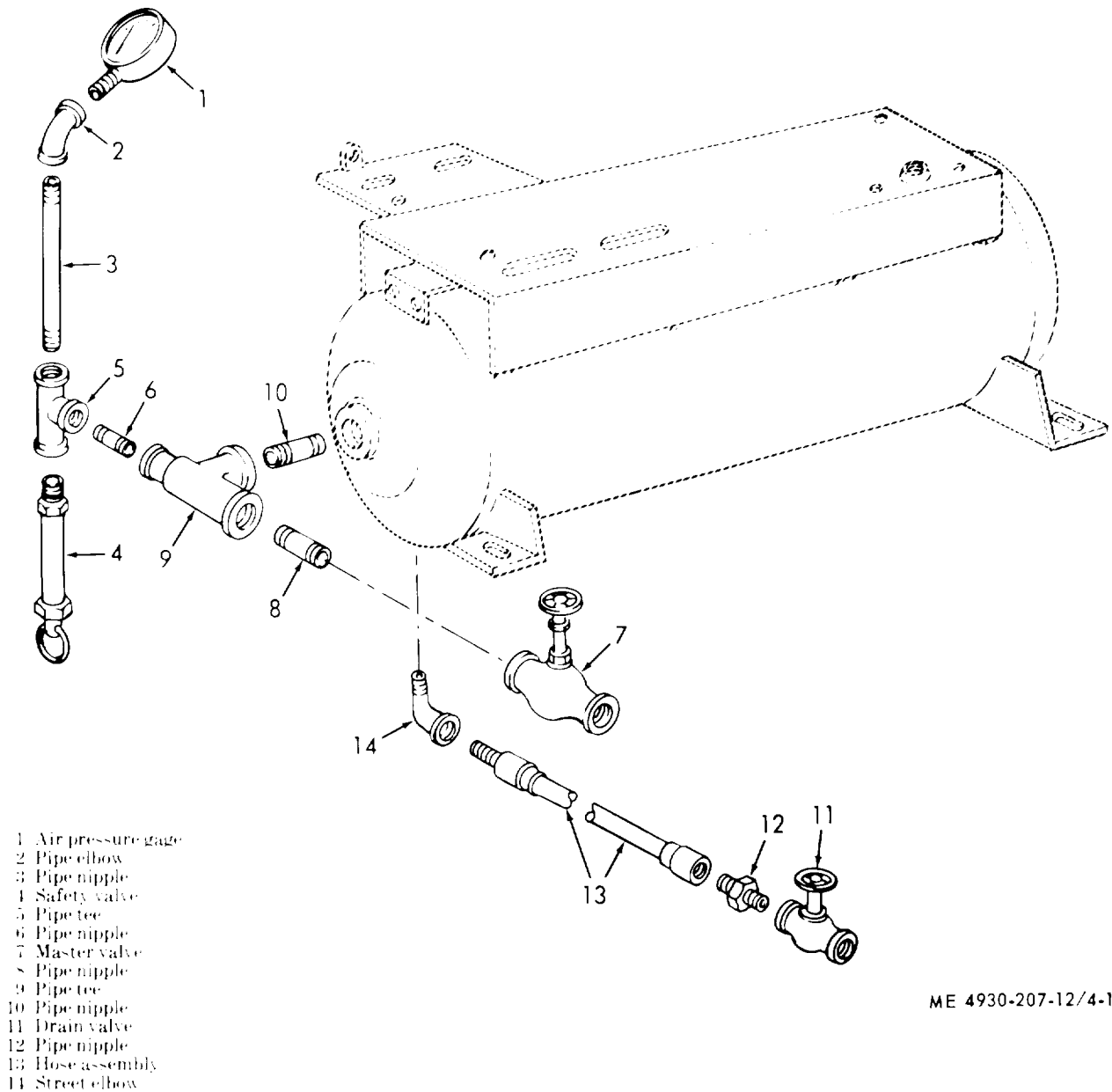

Figure 4-16. Air compressor, removal and installation.

(3) Remove the air receiver lines and fittings in numerical sequence as illustrated in figure 4-17.



ME 4930-207-12/4-17

Figure 4-17. Air receiver lines and fittings, removal and installation

b. Inspection and Repair.

- (1) Inspect all tubing and hoses for cracks, dents or leaks which would hamper their function.
- (2) Inspect all fittings and elbows for damaged threads or internal restrictions.
- (3) Inspect air pressure gage for cracked glass or other damage.
- (4) Repair by replacing defective parts.

c. Installation.

- (1) Install the air receiver lines and fittings in the reverse of numerical sequence as illustrated in figure 4-17.
- (2) Install the compressor hose, lines and fittings as illustrated in figure 4-17.

4-25. Air Relief Valve

a. Removal.

- (1) Open air receiver drain valve (fig. 2-4), and release all pressure from air receiver.
- (2) Remove relief valve (4, fig. 4-17) by unscrewing from tee (5).

b. Inspection and Repair.

- (1) Inspect the valve for worn or damaged parts.
- (2) Replace a defective relief valve.

- c. Installation.** Install the air relief valve (4) in tee (5).

4-26. Pilot Valve

a. Removal.

- (1) Open air receiver drain valve (fig. 2-4) and

release all pressure from air receiver.

(2) Refer to figure 4-16 and unscrew the pilot valve from the air receiver.

b. Inspection and Repair.

(1) Inspect the pilot valve for worn or damaged parts.

(2) Replace a defective pilot valve.

c. Installation. Refer to figure 4-16 and install the pilot valve in the air receiver.

4-27. Air Compressor

a. Removal.

(1) Remove the compressor drive belt guard and drive belt (para 3-17).

(2) Open the air receiver drain valve (fig. 2-4)

and release all pressure from air receiver.

(3) Open compressor crankcase drain cock (fig. 4-16) and drain the crankcase.

(4) Remove the air compressor assembly as illustrated in figure 4-16.

b. Inspection and Repair. Inspect and repair the compressor air lines (para 4-24).

c. Installation.

(1) Install the air compressor assembly as illustrated in figure 4-16.

(2) Install the compressor drive belt and belt guard (para 3-17).

(3) Refer to LO 5-4930-207-12 and service the compressor crankcase.

Section VII. AIR LUBRICATION SYSTEM

4-28. General

The air lubricating system contains the components which furnishes regulated and processed air (alcohol mist) to the air motor pumps, which dispenses lubricating fluid through hose reels and control valves.

4-29. Air Regulator Valve

a. Removal.

(1) Open the air receiver drain valve (fig. 2-4) and release all air pressure from the air receiver.

(2) Remove the air regulator and lines in numerical sequence as illustrated in figure 4-18.

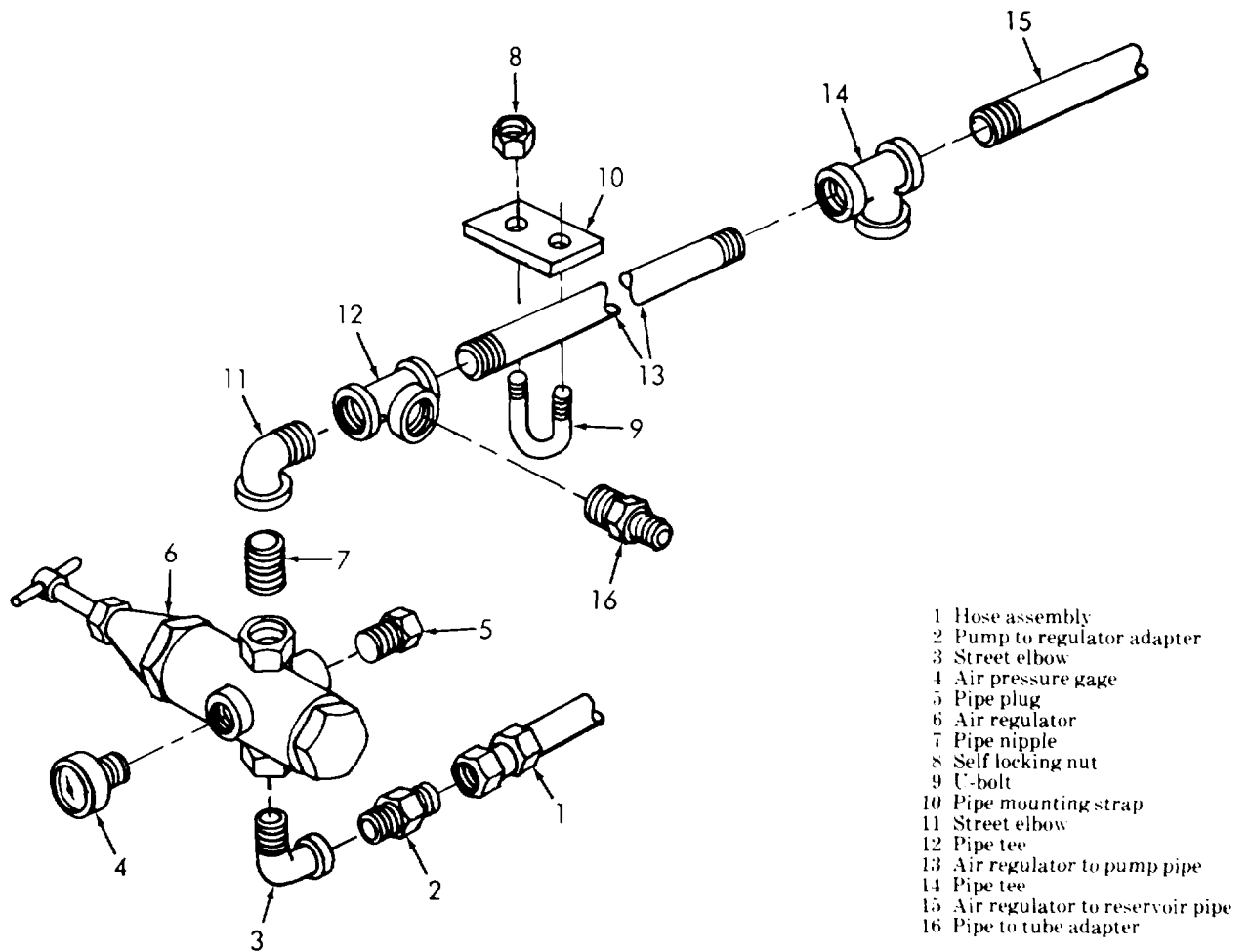

- 1 Hose assembly
- 2 Pump to regulator adapter
- 3 Street elbow
- 4 Air pressure gage
- 5 Pipe plug
- 6 Air regulator
- 7 Pipe nipple
- 8 Self locking nut
- 9 U-bolt
- 10 Pipe mounting strap
- 11 Street elbow
- 12 Pipe tee
- 13 Air regulator to pump pipe
- 14 Pipe tee
- 15 Air regulator to reservoir pipe
- 16 Pipe to tube adapter

ME 4930-207-12/4-18

Figure 4-18. Air regulator valve, removal and installation.

b. Disassembly. Disassemble the air regulator in numerical sequence as illustrated in figure 4-19.

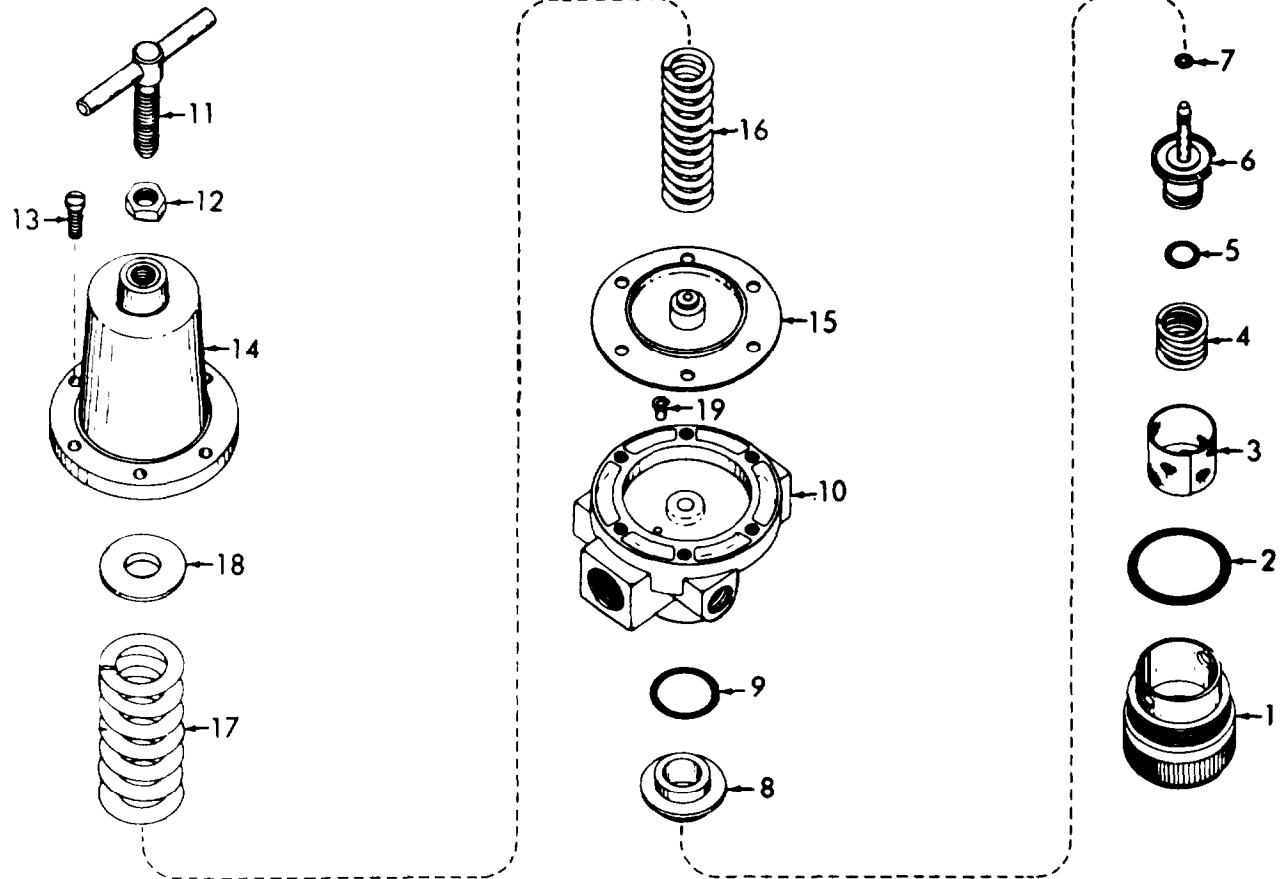

ME 4930-207-12/4-19

- | | |
|-----------------------|---------------------|
| 1 Plug | 11 Screw handle |
| 2 Preformed packing | 12 Lock nut |
| 3 Screen | 13 Machine screw |
| 4 Spring | 14 Bonnet assembly |
| 5 Preformed packing | 15 Diaphragm |
| 6 Valve | 16 Diaphragm spring |
| 7 Preformed packing | 17 Spring |
| 8 Valve seat | 18 Spring plate |
| 9 Preformed packing | 19 Pin |
| 10 Air regulator body | |

Figure 4-19. Air regulator, disassembly and reassembly

c. Inspection and Repair.

(1) Inspect all parts for damage or excessive wear.

(2) Discard and replace all preformed packings and diaphragm.

(3) Replace all other defective parts.

d. Reassembly. Reassemble the air regulator assembly in the reverse of numerical sequence as illustrated in figure 4-19.

e. Installation. Install the air regulator and lines

in the reverse of numerical sequence as illustrated in figure 4-18.

4-30. Lubricant Pumps

a. Removal.

(1) Remove the lubricating unit enclosure assembly (para 4-6).

(2) Remove the air regulator (para 4-29).

(3) Remove the lubricant pump as illustrated in figure 4-20.

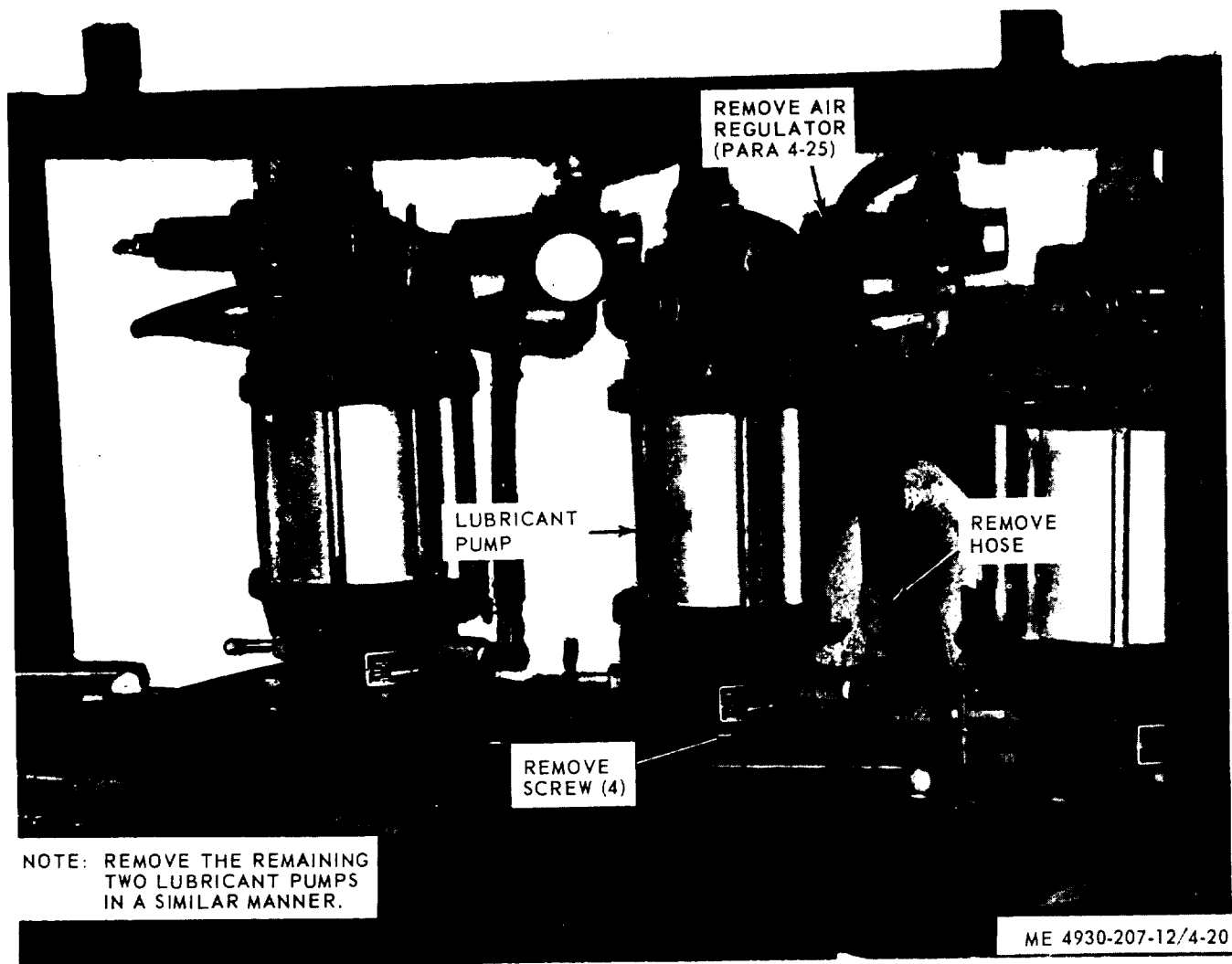

Figure 4-20 Lubricant pump, removal and installation.

b. Installation.

- (1) Install the lubricant pump as illustrated in figure 4-20.
- (2) Install the air regulator (para 4-29).
- (3) Install the lubricating unit enclosure assembly (para 4-6).

bly (para 4-6).

4-31. Lubricant Tank Covers

- a. Removal.* Remove the lubricant reservoir cover in numerical sequence as illustrated in figure 4-21.

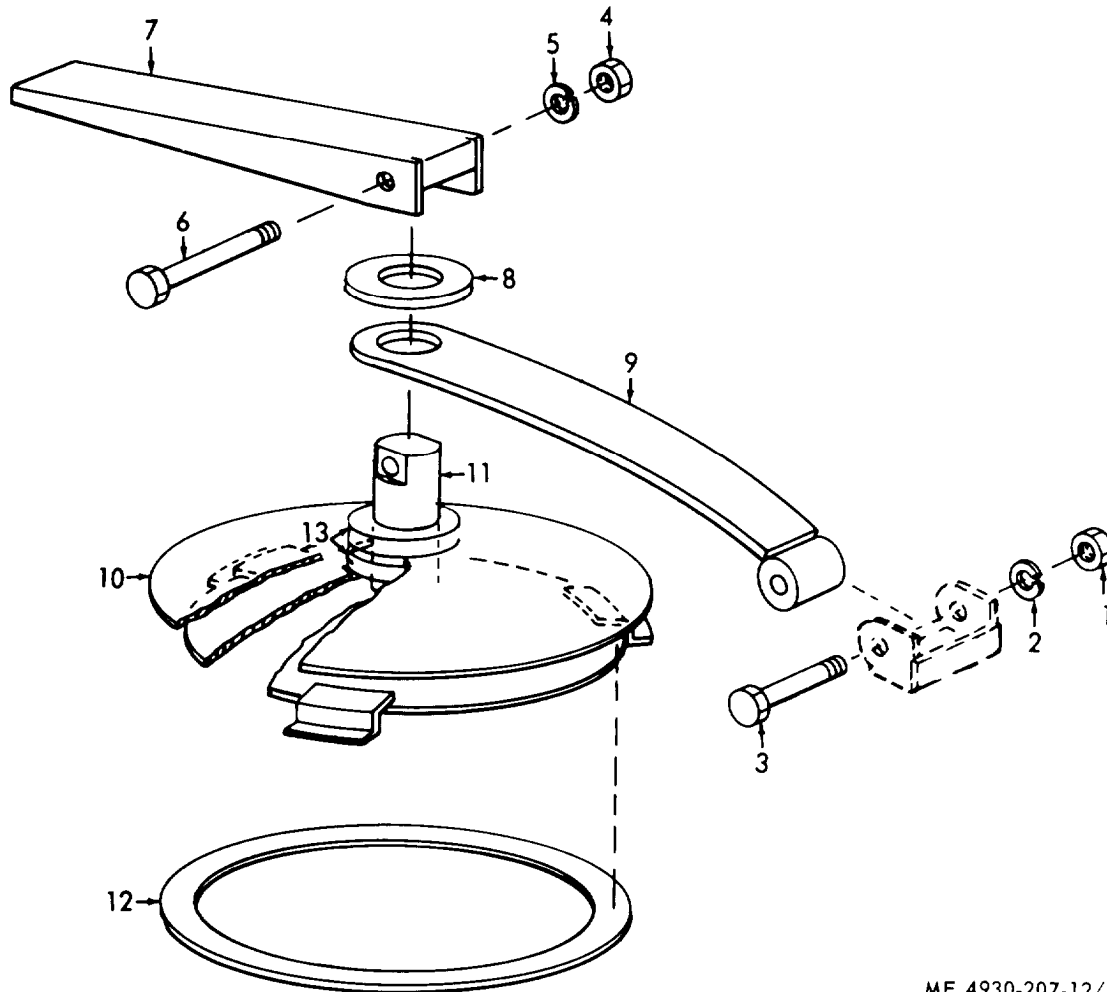

ME 4930-207-12/4-21

- | | |
|-----------------|----------------------|
| 1 Plain hex nut | 8 Flatwasher |
| 2 Lockwasher | 9 Arm support |
| 3 Machine bolt | 10 Tank cover |
| 4 Plain hex nut | 11 Plate cam |
| 5 Lockwasher | 12 Tank cover gasket |
| 6 Machine bolt | 13 Cover spacer |
| 7 Cover handle | |

Figure 4-21. Lubricant tank cover, removal and installation.

b. Inspection and Repair.

(1) Inspect all parts for cracks, breaks, bends or other damage.

(2) Discard and replace tank cover gaskets.

(3) Replace all defective parts.

c. Installation. Install the lubricant cover in the

reverse of numerical sequence as illustrated in figure 4-21.

4-32. Lubricant Valves and Meters

a. Removal. Remove the gear lubricant, engine oil meters and grease valves as illustrated in figure 4-22.

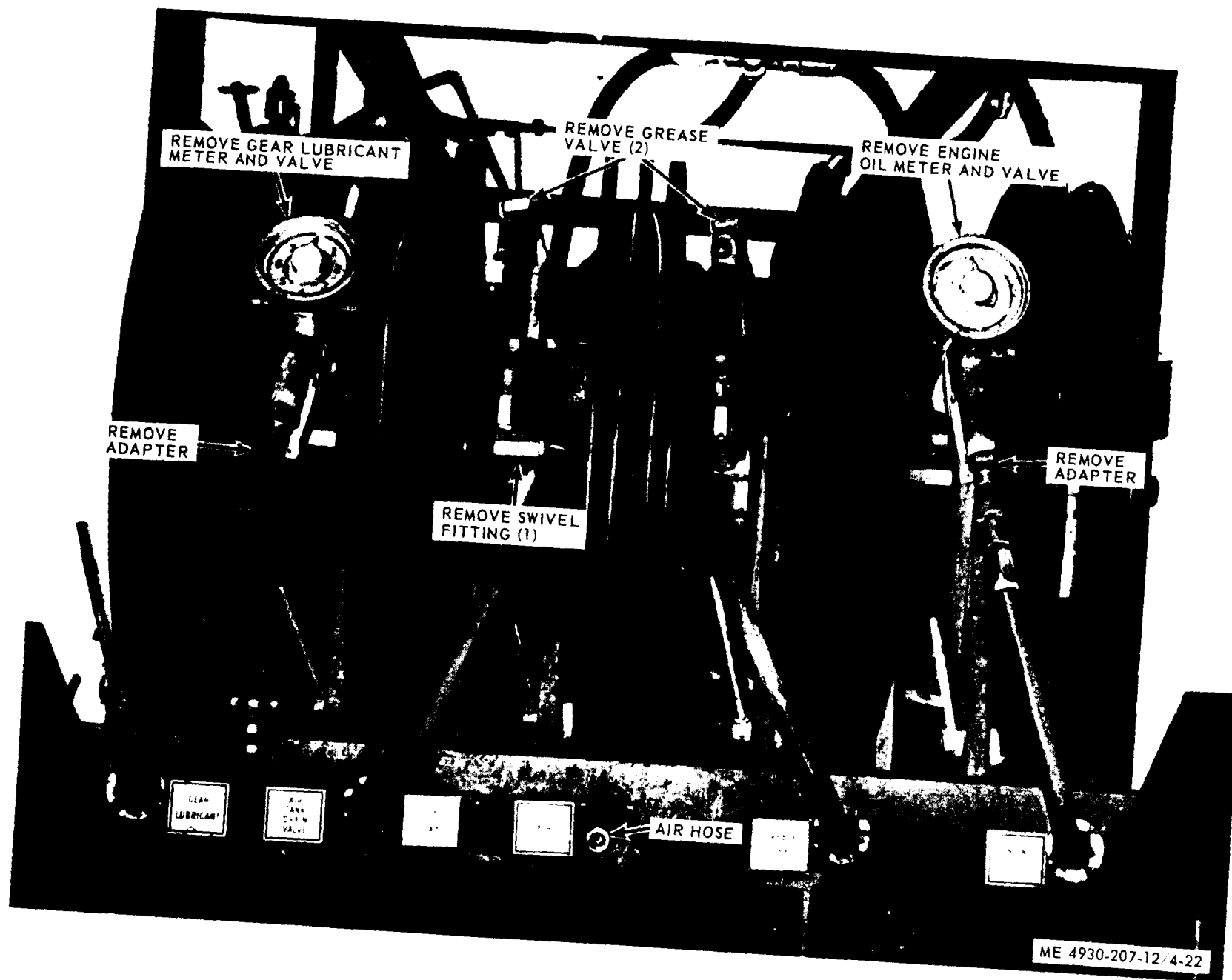

Figure 4-22. Lubricant valves and meters, removal and installation.

b. Inspection and Repair.

(1) Inspect fittings, valves and meters for damaged threads, external damage or internal obstruction.

(2) Replace all defective parts.

c. Installation. Install grease valves, gear lubricant and engine oil meters as illustrated in figure 4-22.

4-33. Lubricant and Air Hoses

a. Removal.

(1) Remove the gear lubricant valves and meters (para 4-32).

(2) Remove the lubricant and air hoses as illustrated in figure 4-23.

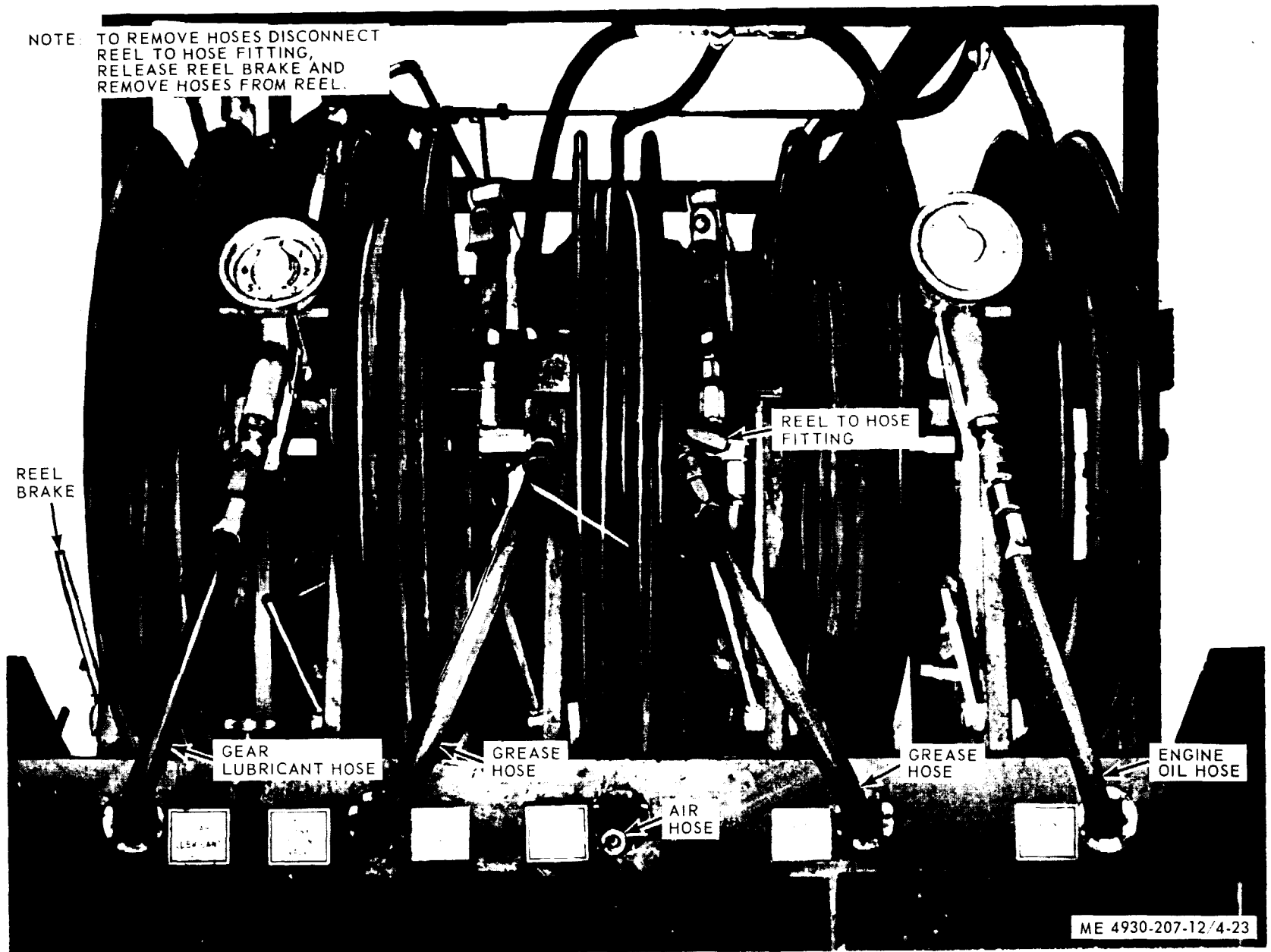

Figure 4-23. Lubricant and air hoses, removal and installation.

b. Inspection and Repair.

(1) Inspect hoses for cracks, breaks or other damage.

(2) Inspect adapters and fittings for damaged threads or internal obstruction.

(3) Repair by replacement of defective parts.

c. Installation.

(1) Install the lubricant and air hoses as illustrated in figure 4-23.

(2) Install the gear lubricant valves and meters

(para 4-32)

4-34. Hose Reel Assembly

a. Removal.

(1) Remove the lubricant valves and meters (para 4-32).

(2) Remove the lubricant and air hoses (para 4-33).

(3) Remove the hose reel assembly as illustrated in figure 4-24.

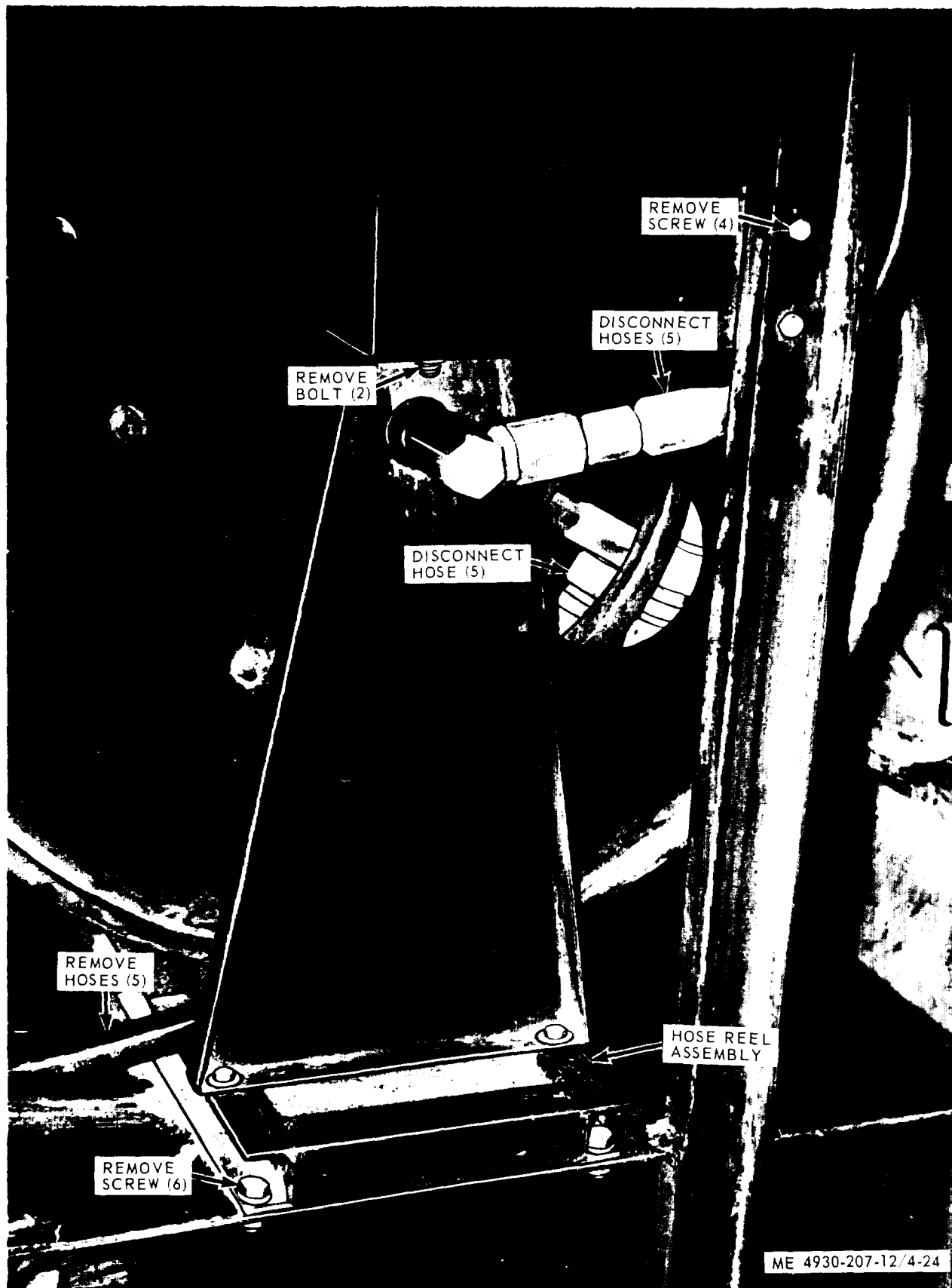

Figure 4-24. Hose assembly, removal and installation.

(4) Remove the individual hose reel banks in numerical sequence as illustrated in figure 4-25.

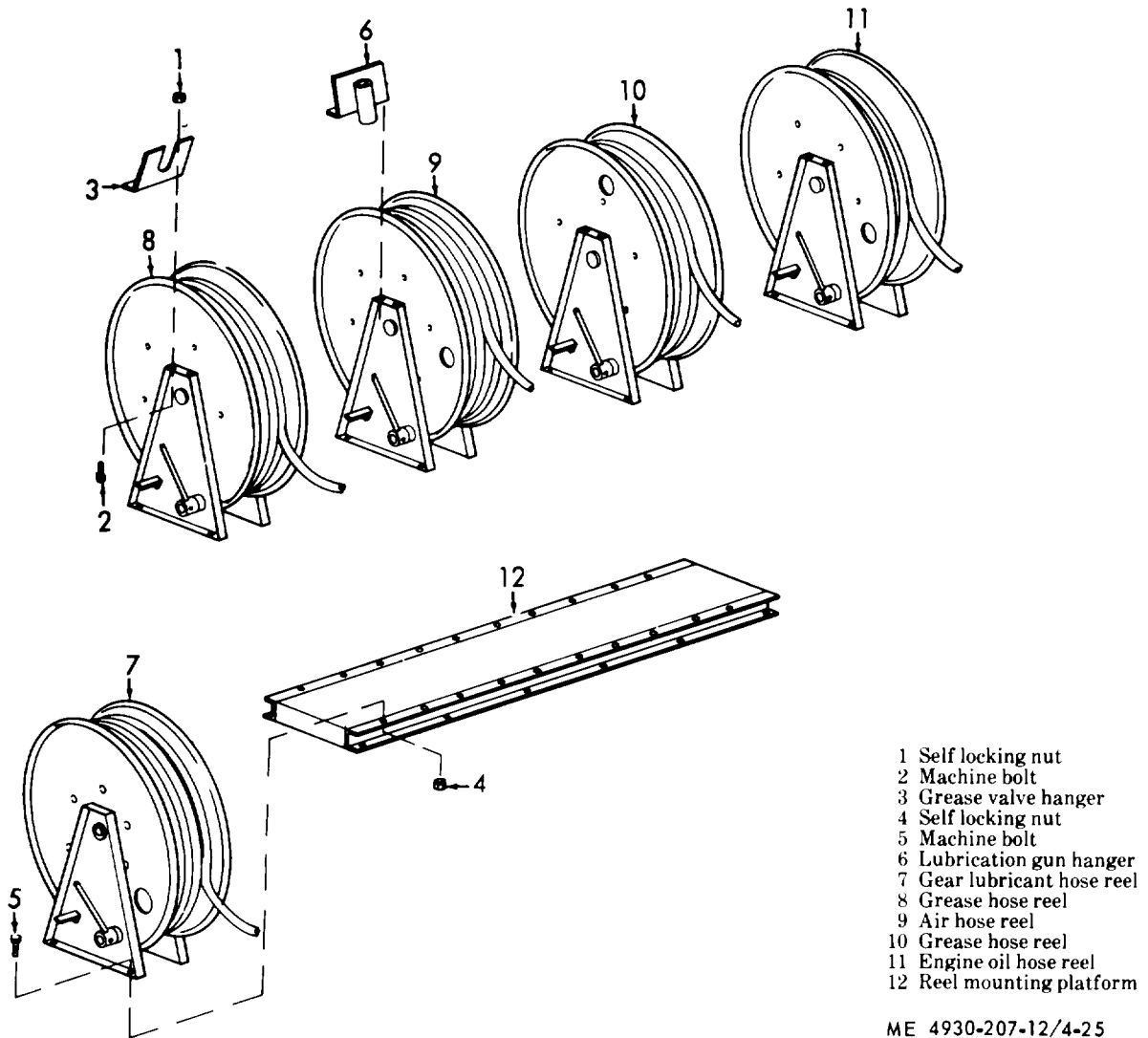

Figure 4-25. Hose reel bank, removal and installation.

b. Installation.

(1) Install the individual hose reel banks in the reverse of numerical sequence as illustrated in figure 4-25.

(2) Install the hose reel assembly as illustrated in figure 4-24.

(3) Install the lubricant and air hoses (para 4-33).

(4) Install the lubricant valves and meters (para 4-34).

4-35. Alcohol Dispenser

a. Removal. Remove the alcohol dispenser as illustrated in figure 4-26.

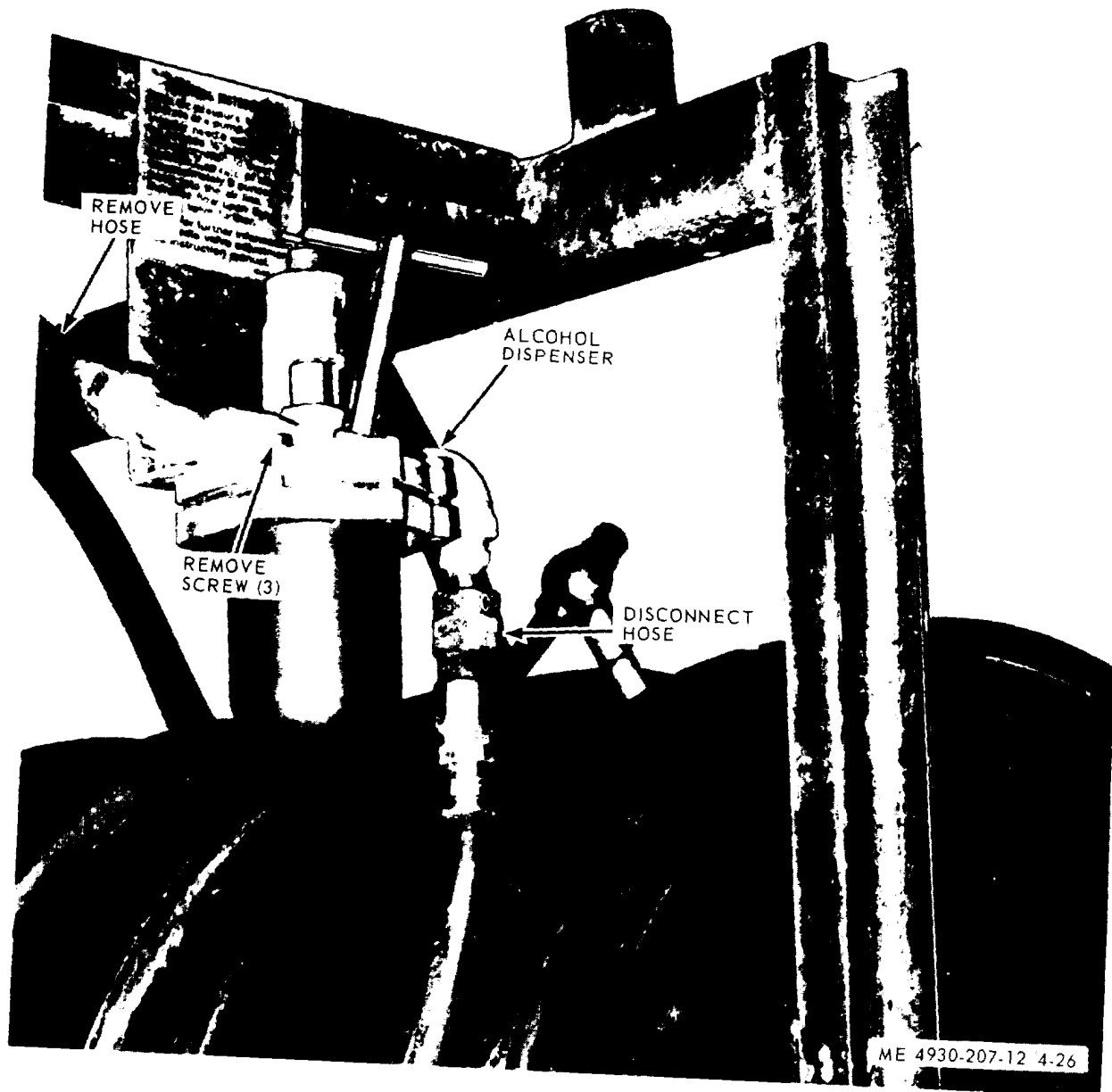

Figure 4-26. Alcohol dispenser, removal and installation.

b. Disassembly. Disassemble the alcohol dispenser in numerical sequence as illustrated in figure 4-27.

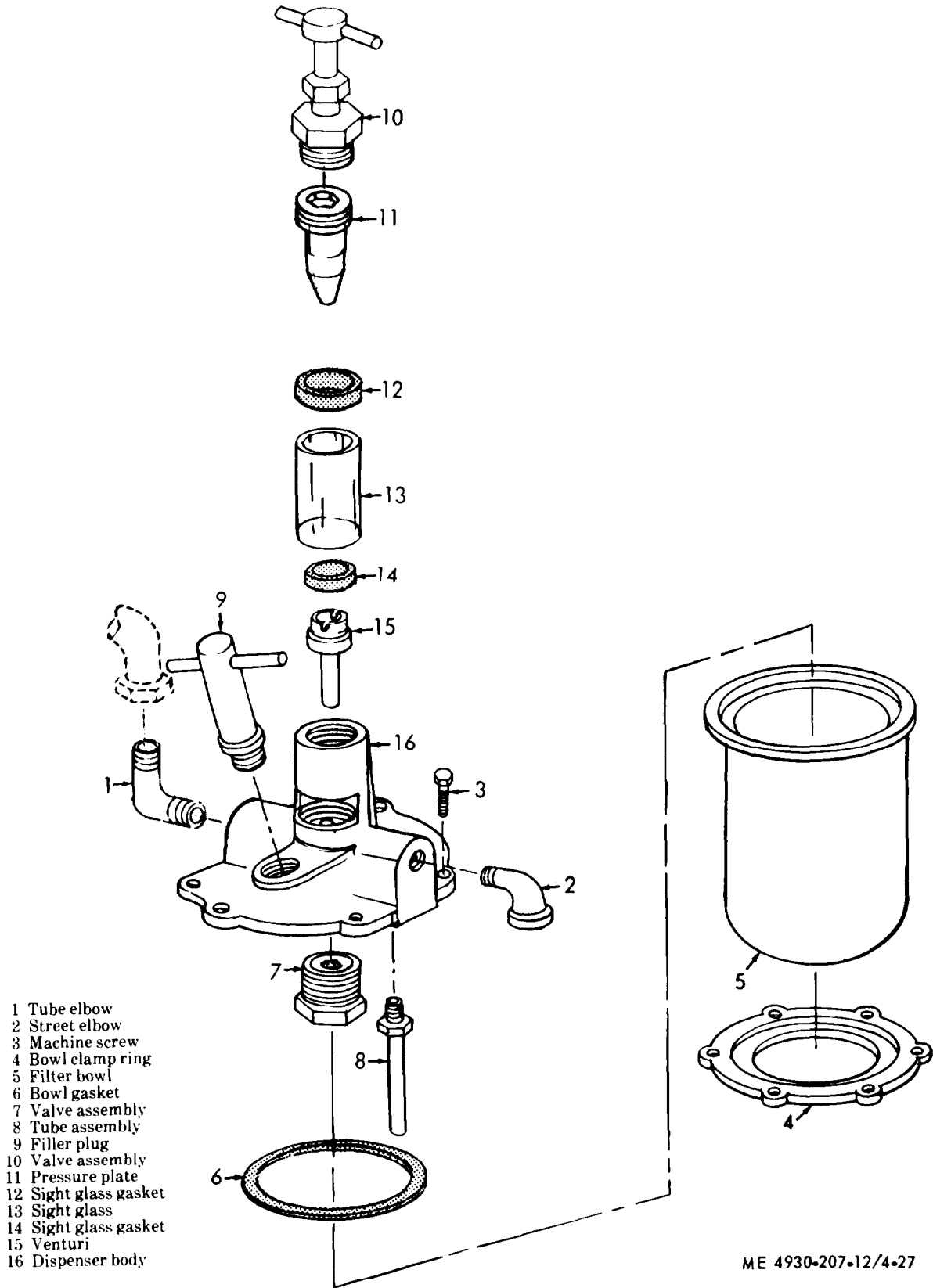

Figure 4-27. Alcohol dispenser, disassembly and reassembly.

c. Inspection and Repair.

- (1) Inspect all threaded fittings for thread damage or internal obstructions.
- (2) Inspect valve assembly and venturi for damage or excessive wear.
- (3) Inspect sight glass for cracks or breaks.
- (4) Discard and replace all gaskets. Replace all other defective parts.

d. Reassembly. Reassemble the alcohol dispenser in the reverse of numerical sequence as illustrated in figure 4-27.

e. Installation.

- (1) Install the alcohol dispenser as illustrated in figure 4-26.
- (2) Service the alcohol dispenser (fig. 2-14).

Section VIII. ENGINE AND CLUTCH

4-36. General

a. Engine. The engine assembly is a military standard, 4 cylinder, air cooled, overhead valve gasoline engine capable of operation in all temperatures when properly serviced. For maintenance of the internal engine components refer to TM 5-2805-203-14.

b. Clutch Assembly. The clutch assembly is mounted on the rear of the engine and consists of a clutch retainer, clutch shaft, and clutch and the necessary attaching parts. The clutch is made up of a center, end and sliding clutch discs and operates as a variable speed pulley. The clutch is hand operated by means of a fore handle.

4-37. Clutch Assembly.

a. Clutch Adjustment. No adjustment to the clutch is possible other than belt alignment. Align belts so they are in line with opposite pulley when clutch is disengaged. Belt should drive slightly out-of-line when clutch is engaged. This alignment is necessary if belt "creeps" when compressor declutched.

b. Removal.

- (1) Remove the compressor drive belt guard and drive belt (para 3-17).
- (2) Remove hex nuts (26 and 27, fig. 4-28), bolts (22 and 23), washers (21 and 24) and fork (25).

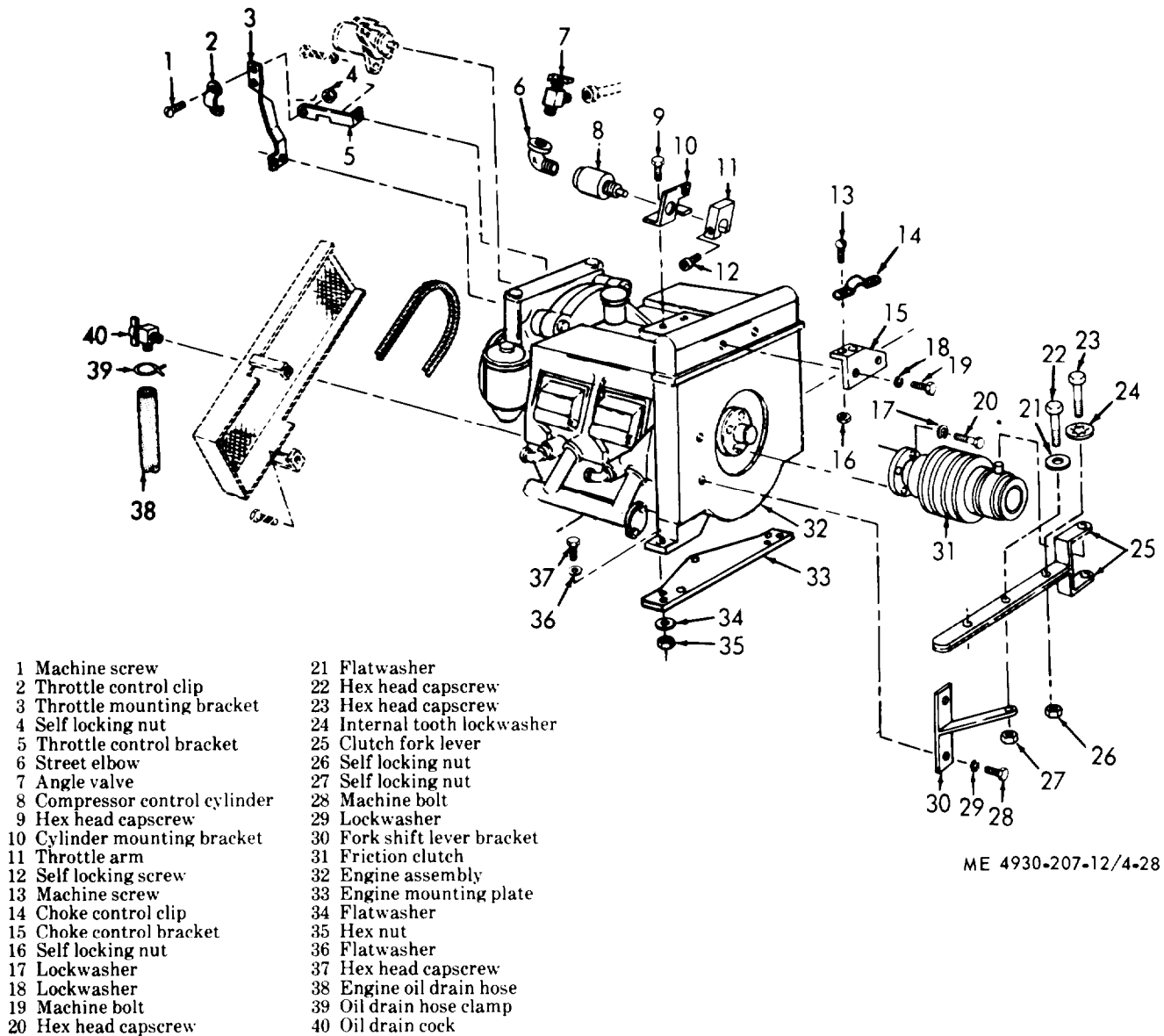

Figure 4-28. Engine and clutch, removal and installation.

(3) Remove four hex screws (20) and lockwashers (17) securing the friction clutch (31) to the engine crankshaft and remove the friction clutch.

c. Cleaning, Inspection and Repair.

(1) Clean the friction clutch by flushing with kerosene. Blow dry with clean, moisture free compressed air.

(2) Inspect clutch balls for wear or flattening. Inspect entire clutch for damaged or worn parts.

(3) Replace a defective clutch.

d. Installation.

(1) Position friction clutch (31, fig. 4-28) on engine crankshaft and secure with four lockwashers (17) and cap screws (20).

(2) Position fork lever (25) on friction clutch (31) and lever bracket (30) and install washers (21 and 24), cap screws (22 and 23) and self locking nuts (26 and 27).

(3) Adjust the clutch (a above).

(4) Install the compressor drive belt, and belt guard (para 3-17).

4-38. Engine Assembly

a. Removal.

(1) Remove the lubrication unit enclosure assembly (para 4-6).

(2) Use a suitable container and drain the engine crankcase by opening draincock (40), remove clamp

(39) and hose (38).

(3) Remove the friction clutch (para 4-37).

(4) Disconnect the two exhaust pipes at the engine manifolds.

(5) Disconnect throttle control and fuel line at the carburetor.

(6) Disconnect the starter cable (fig. 4-5) at the starter and ground cable at back of engine.

(7) Refer to figure 4-6 and remove the oil pressure switch, oil temperature switch and oil pressure transmitter.

(8) Remove four nuts (35, fig. 4-28), washers (34), bolts (37) and washers (36). Attach a suitable hoist and remove the engine assembly (32) and mounting plates (33).

b. Installation.

(1) Position engine mounting plates (33, fig. 2-28) on lubricator frame. Use a suitable lifting device and install the engine assembly, and secure with four

capscrews (37), washers (36), washers (34) and hex nuts (35).

(2) Refer to figure 4-6 and install the oil pressure transmitter, oil temperature switch and oil pressure switch. Remove electrical lead identification tags installed during removal.

(3) Connect the starter cable (fig. 4-5) to the starter and install ground cable at rear of engine.

(4) Connect the throttle control and fuel line to the carburetor.

(5) Install the two exhaust pipes on engine manifolds.

(6) Install the friction clutch (para 4-37).

(7) Install hose (38) on drain cock (40) and secure with clamps (49).

(8) Service the engine, TM 5-2805-203-14.

(9) Install the lubrication unit enclosure assembly (para 4-2).

Section IX. TRAILER WHEELS AND BRAKES

4-39. General

a. Wheels. Each wheel is supported by two tapered roller bearings. A seal and hub cap protect the wheel bearings from dirt and foreign matter and retain the bearing lubricant.

b. Brakes.

(1) The service brakes are the "air over hydraulic" type. Air pressure is used to operate the hydraulic braking mechanism, applying the brakes with pressure in ratio to foot pressure applied to brake pedal of the towing vehicle.

(2) The trailer service brakes consist of intervehicular air hoses, air filters, relay emergency valve,

air pressure tank, brake air chamber, master cylinder, wheel cylinders, hydraulic lines and fittings and the necessary air lines and fittings. Each wheel brake shoe is anchored to the back plate, on which it is allowed to expand and contact the brake drum without binding. Hydraulic wheel cylinders mounted at top and bottom actuate the brake shoes during operation.

4-40. Wheel and Tire

a. Removal. Remove the wheel and tire as illustrated in figure 4-29.

NOTE: BLOCK OPPOSITE WHEEL, USE A SUITABLE JACK AND RAISE WHEEL.

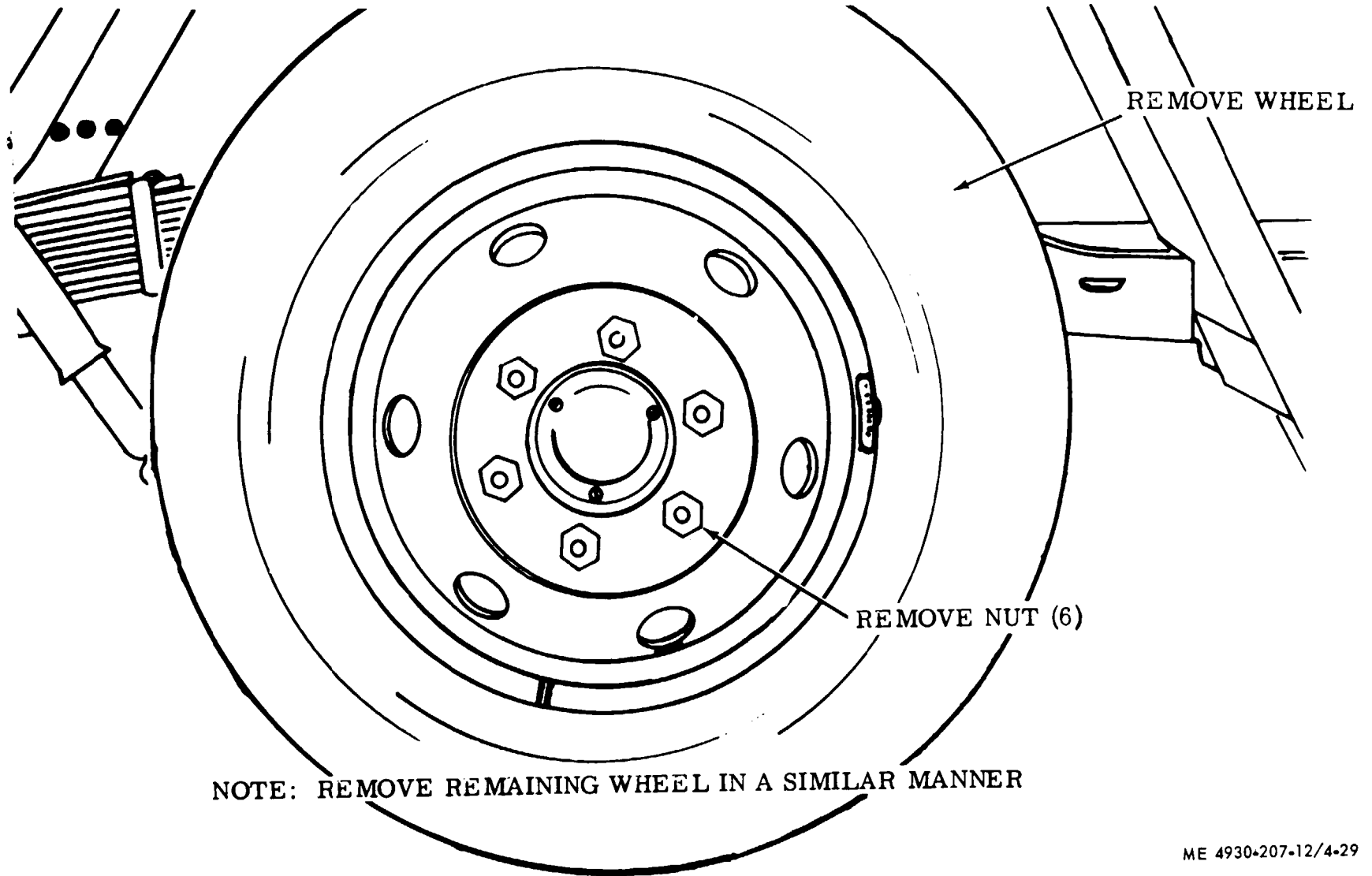

NOTE: REMOVE REMAINING WHEEL IN A SIMILAR MANNER

ME 4930-207-12/4-29

Figure 4-29. Wheel and tire, removal and installation.

b. Inspection and Repair.

(1) Refer to TM 9-1870-1 for removal, installation and repair of tires.

(2) Inspect tire and tube for cuts, cracks, breaks or other damage.

(3) Replace a damaged or defective tire or tube.

(4) Refer to paragraph 1-4 and inflate the tire.

c. Installation. Install the wheel and tire as illustrated in figure 4-29.

4-41. Wheel Hub and Brake Drum

a. Removal and Disassembly.

(1) Remove the wheel and tire (para 4-40).

(2) Release brake and pressure by opening drain cock (fig. 3-5) at the air reservoir.

(3) Remove and disassemble the wheel, hub and brake drum in numerical sequence as illustrated in figure 4-30.

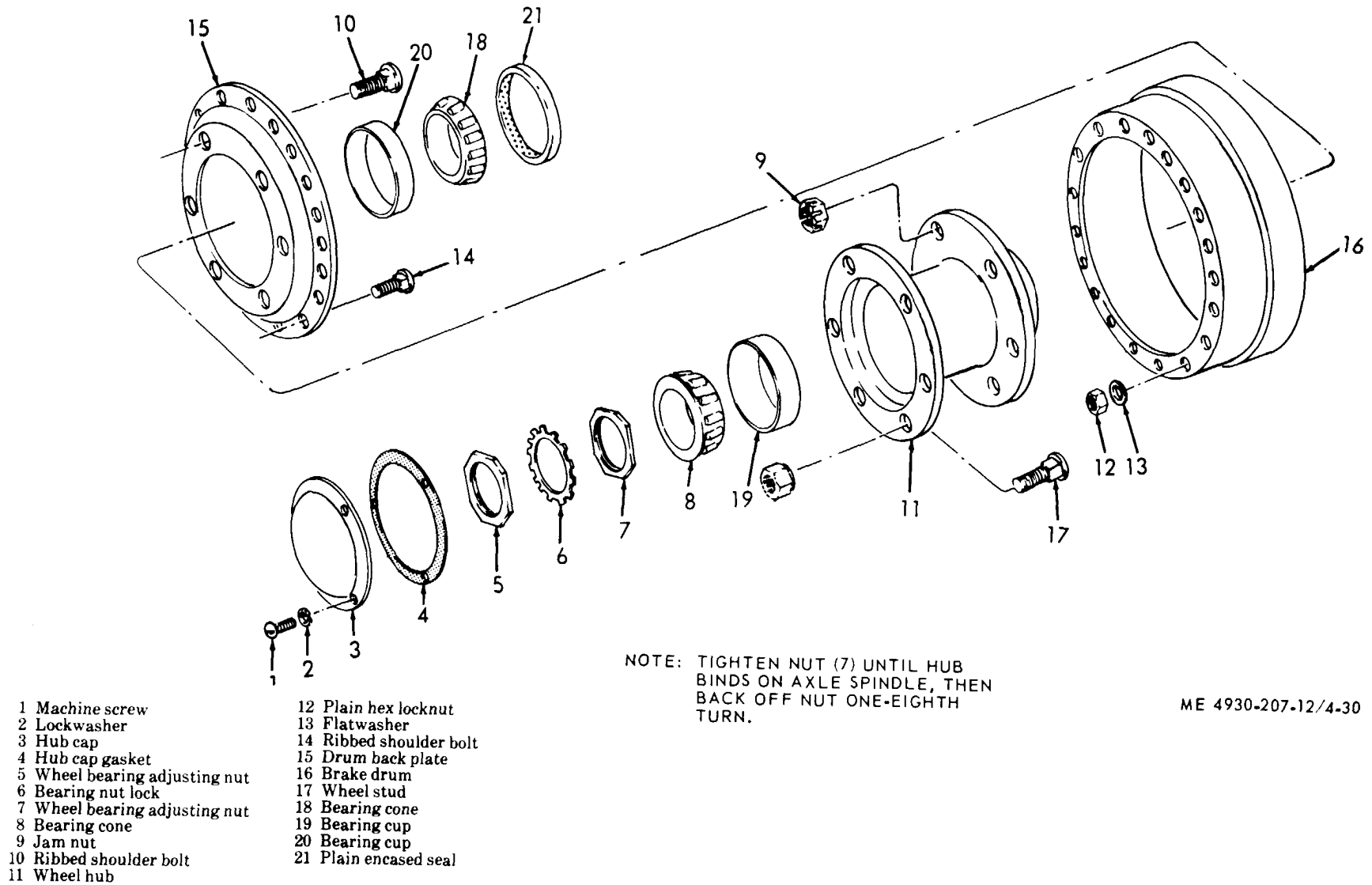

Figure 4-30. Wheel hub and brake drum, removal, disassembly, reassembly and installation.

b. Inspection and Repair.

- (1) Inspect bearing cones and cups for nicks, pitted surfaces or excessive wear.
- (2) Inspect brake drum for excessive wear and brake shoe contact points.
- (3) Inspect remaining parts for cracks, breaks or other damage.
- (4) Discard and replace grease seal and hub cap gaskets.
- (5) Inspect studs and threaded areas for thread damage.
- (6) Replace all defective parts.

c. Reassemble and Installation.

- (1) Reassemble and install the wheel hub and brake drum in the reverse of numerical sequence as illustrated in figure 4-30.

- (2) Tighten nut (7) until hub binds on axle spindle, then back off nut 1/8 turn. Lock in position with lock (6) and nut (5).

- (3) Install the wheel and tire (para 4-40).

4-42. Service Brakes Adjustment and Bleeding

a. Brake Adjustment.

- (1) Release pressure from the air reservoir by opening drain cock (fig. 3-5).

- (2) Jack the trailer and block it so the wheels can be turned by hand.

- (3) Turn the lower adjusting stud (fig. 4-31) counterclockwise until brake lining contacts brake drum with slight drag when drum is rotated by hand. Then turn stud clockwise to allow drum to rotate freely.

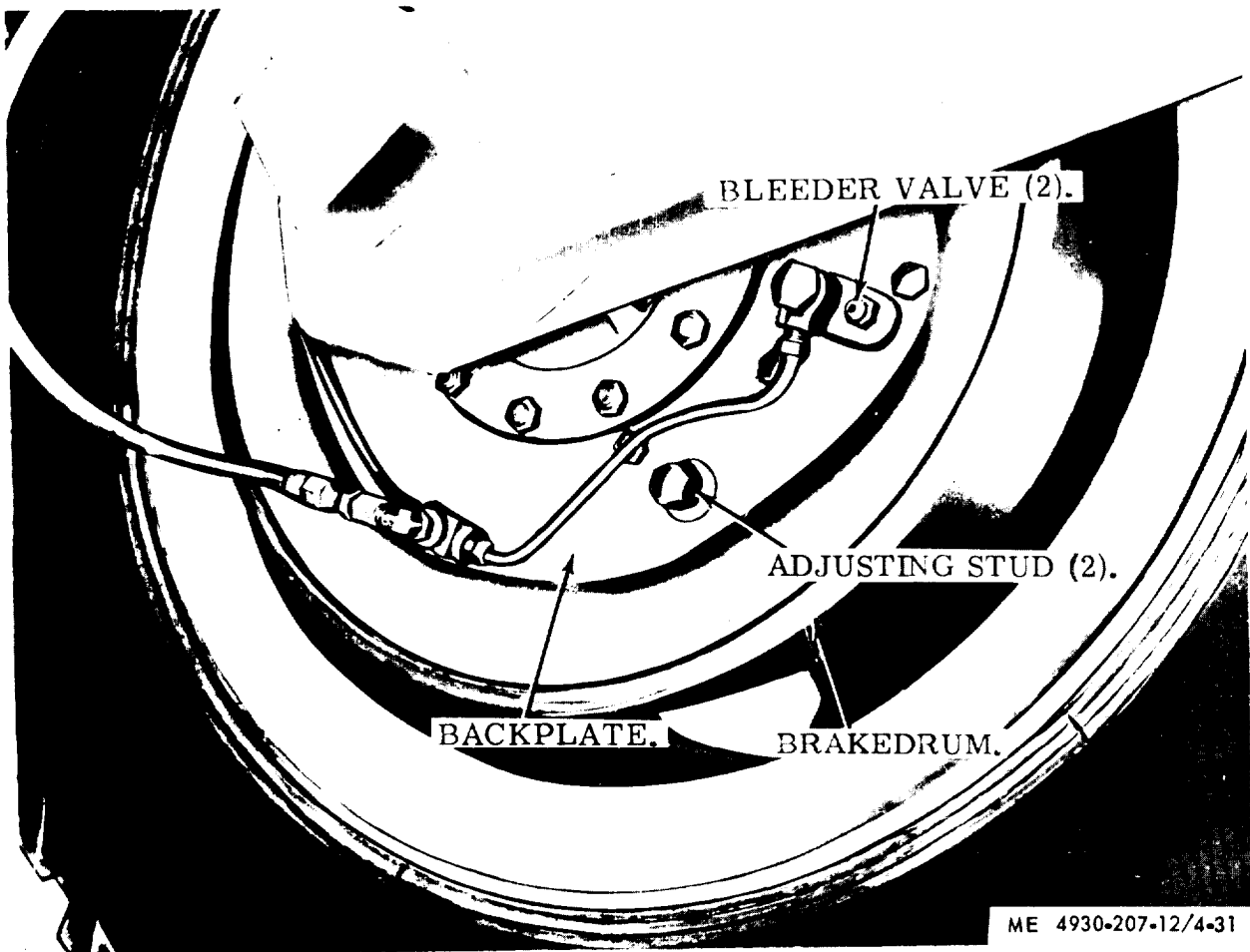

Figure 4-31. Service brake adjustment and bleeding.

- (4) Adjust the top adjusting stud in a similar manner.

- (5) Adjust the opposite wheel in a similar manner.

b. Bleeding Brakes.

- (1) *General.* It is necessary to bleed the air from the hydraulic portion of service brakes if the system is opened or a component of the system has been removed.

(2) Manual bleeding.

(a) Connect trailer service brake hose to a towing vehicle (fig. 2-2) for manual bleeding as the brake pedal must be pressed and released to actuate the brake system. The master cylinder must be kept full of brake fluid or air will enter the system.

(b) Clean the bleeder valve (fig. 4-31) with a clean cloth. Attach a bleeder hose to the bleeder valve and place the other end of the hose in a suitable container.

(c) Fill the master cylinder with brake fluid.

(d) Pump brake pedal on towing vehicle until pressure is applied. Hold pedal pressure and open bleeder valve (fig. 4-31) until pressure is released on pedal, then close bleeder valve.

(e) Repeat this action until fluid has replaced air in the system, then close the valve and remove the bleeder hose.

(f) Refill master cylinder and install the filler cap.

(g) Repeat this operation on the opposite wheel.

CAUTION

Maintain a high level of fluid in the master cylinder while bleeding each wheel cylinder.

(3) Pressure Feed Filler Bleeding.

(a) Remove the filler cap from the master cylinder.

(b) Connect a hose to a pressure feed filler using a proper size adapter, to the opening in the master cylinder.

(c) The pressure filler must contain from 10 to 20 psi air pressure and sufficient fluid to maintain constant fluid level in the master cylinder.

(d) Proceed to bleed the system as in manual bleeding ((2) above).

(e) Replenish fluid in the master cylinder after bleeding, if necessary.

4-43. Wheel Cylinders and Brake Shoes

a. Removal.

(1) Release the brake air pressure by opening draincock (fig. 3-5), at the air reservoir.

(2) Remove three screws (1, fig. 4-30), washers (2), cap (3), gasket (4), nut (5), lock (6), nut (7), and bearing cone (8) securing the wheel and drum assembly and remove wheel and drum.

(3) Remove the wheel cylinders and brake shoes as illustrated in figure 4-32.

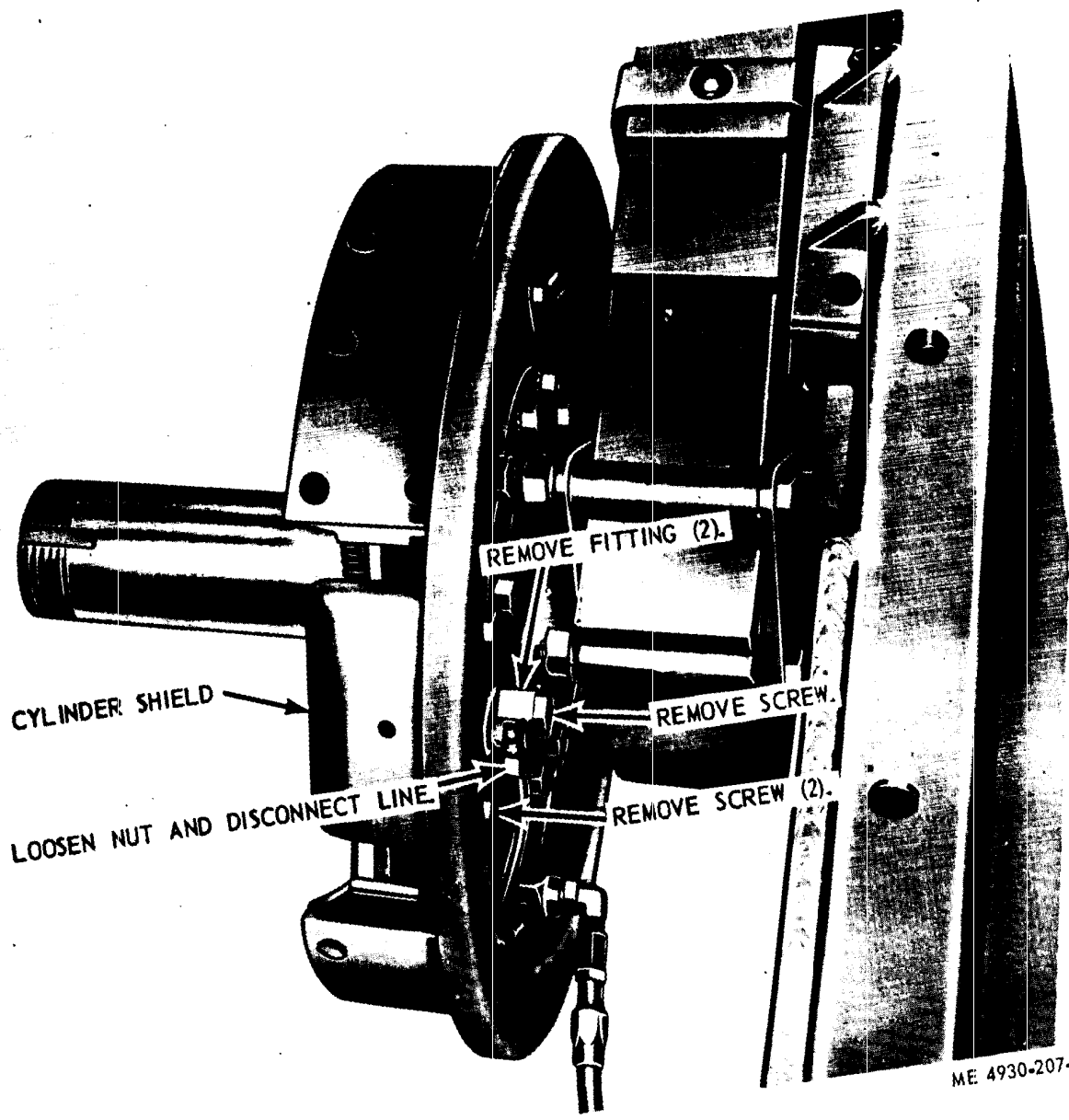

ME 4930-207-12/4-32 ①

Figure 4-32. Wheel cylinder and brake shoe, removal and installation (sheet 1 of 2).

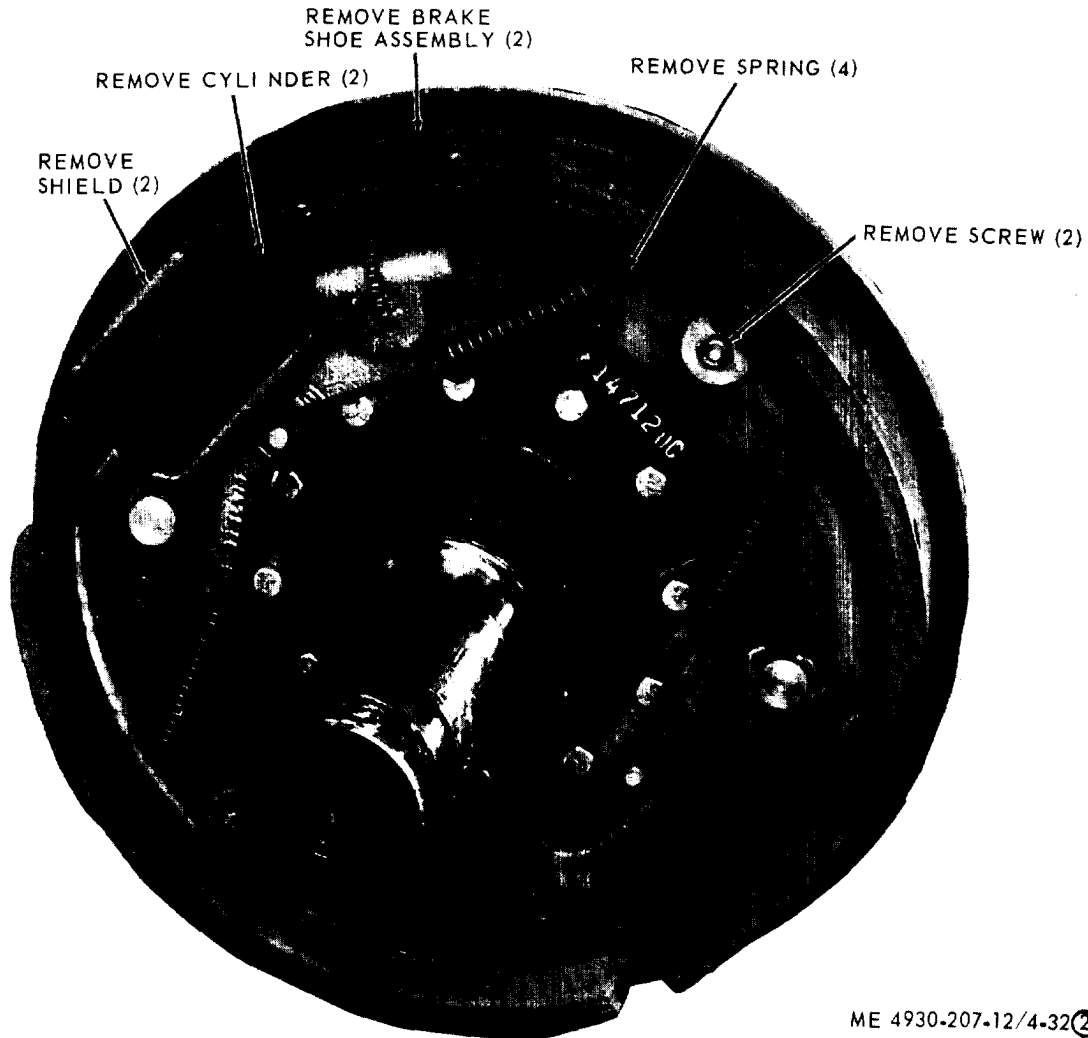

ME 4930-207-12/4-32(2)

Figure 4-32. Wheel cylinder and brake shoe, removal and installation (sheet 2 of 2)

b. Inspection and Repair.

- (1) Inspect brake lines for cracks, bends, kinks or other damage.
- (2) Inspect all threaded areas for damaged threads.
- (3) Inspect brake shoes for excessive wear.
- (4) Inspect wheel cylinder for leaks at the rubber boot.

(5) Replace all defective parts. Report a defective wheel cylinder to direct support maintenance.

c. Installation.

- (1) Install the brake shoes and wheel cylinders as illustrated in figure 4-32.
- (2) Install the wheel and drum assembly, bearing

cone (8, fig. 4-30) and secure with nut (7). Tighten nut (7) until hub binds on axle spindle, then back off the nut 1/8 turn.

(3) Install lock (6), nut (5), gasket (4), cap (3) and secure with washers (2) and screws (1).

(4) Adjust and bleed the brakes (para 4-42).

4-44. Hydraulic Master Cylinder

a. Removal.

(1) Release the air brake pressure by opening drain cock (fig. 3-5) at the air reservoir.

(2) Remove the master cylinder as illustrated in figure 4-33.

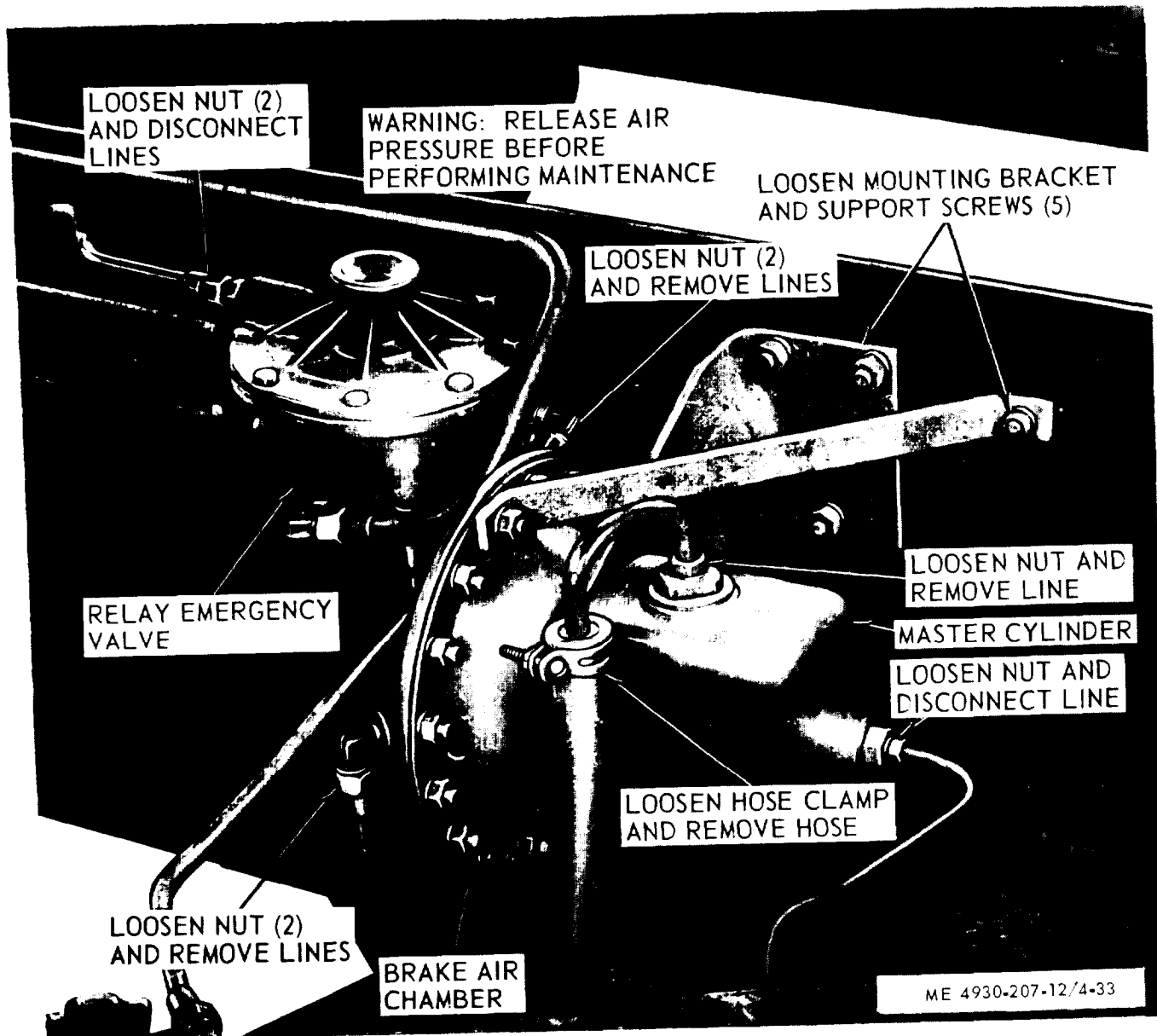

Figure 4-33 Hydraulic master cylinder, brake chamber and relay valve, removal and installation.

b. Inspection and Repair.

- (1) Inspect master cylinder lines for cracks, breaks, kinks or other damage.
- (2) Repair by replacement of defective parts.

c. Installation.

- (1) Install the master cylinder as illustrated in figure 4-33.
- (2) Bleed the hydraulic brake system (para 4-42).

4-45. Brake Air Chamber

a. Removal.

- (1) Release the air brake pressure by opening drain cock (fig. 3-5) at the air reservoir.
- (2) Remove the air brake chamber and master cylinder as illustrated in figure 4-33.

- b. Disassembly.* Disassemble the air brake chamber in numerical sequence as illustrated in figure 4-34.

c. Inspection and Repair.

(1) Inspect part for cracks, breaks or other damage.

(2) Discard and replace the diaphragm. Replace all other defective parts.

d. Reassembly. Reassemble the air brake chamber in the reverse of numerical sequence as illustrated in figure 4-34.

e. Installation.

(1) Install the air brake chamber and master cylinder as illustrated in figure 4-33.

(2) Bleed the hydraulic brake system (para 4-42).

4-46. Brake Relay Emergency Valve

a. Removal.

(1) Release air brake pressure by opening drain cock (fig. 3-5) at the air reservoir.

(2) Remove the relay emergency valve as illustrated in figure 4-33.

b. Inspection and Repair. Inspect valve and mounting parts for damage. Repair by replacement of damaged parts.

c. Installation. Install the relay emergency valve as illustrated in figure 4-33.

4-47. Air Filter

a. Removal.

(1) Release the air brake pressure by opening drain cock (fig. 3-5), at the air reservoir.

(2) Remove the air filter as illustrated in figure 4-35.

b. Inspection and Repair.

(1) Service the air filter (para 3-19).

(2) Inspect all parts for damage. Repair by replacement of defective parts.

c. Installation Install the air filter as illustrated in figure 4-35.

4-48. Air Reservoir

a. Removal.

(1) Release the air brake pressure by opening air release valve (fig. 4-35).

(2) Remove the air reservoir as illustrated in figure 4-35.

b. Inspection and Repair.

(1) Inspect air reservoir for cracks, breaks, leaks or other damage.

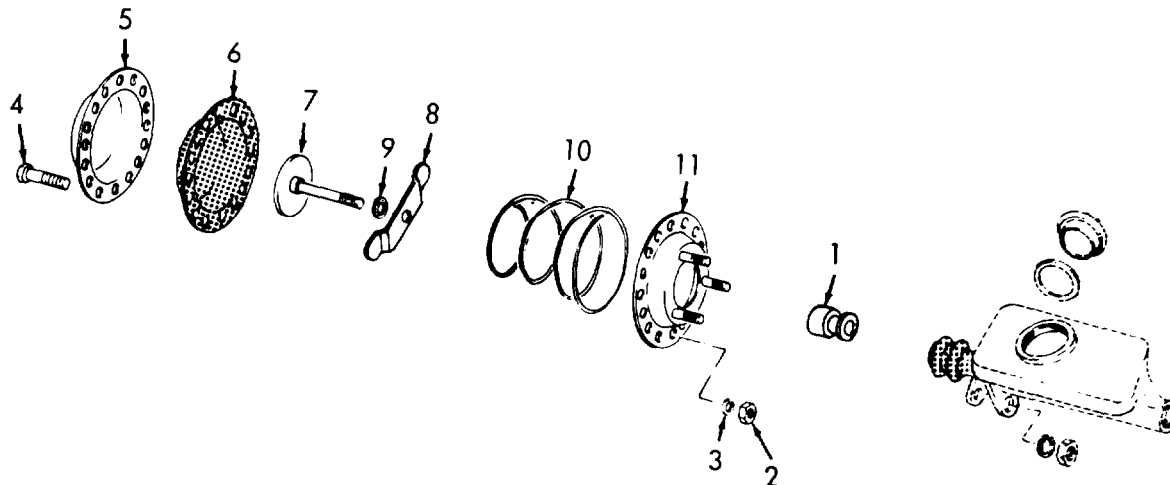

- | | |
|---------------------|------------------------|
| 1 Collar stud | 7 Piston rod |
| 2 Plain hex nut | 8 Spring retaining cup |
| 3 Lockwasher | 9 Preformed packing |
| 4 Hex head capscrew | 10 Helical spring |
| 5 Body cover | 11 Chamber body |
| 6 Chamber diaphragm | |

ME 4930.207-12/4.34

Figure 4-34. Air brake chamber her, disassembly reassembly.

NOTE: REMOVE REMAINING AIR FILTER AND LINES IN A SIMILAR MANNER.

NOTE: REMOVE NECESSARY CLAMPS SECURING AIR LINES TO TRAILER FRAME.

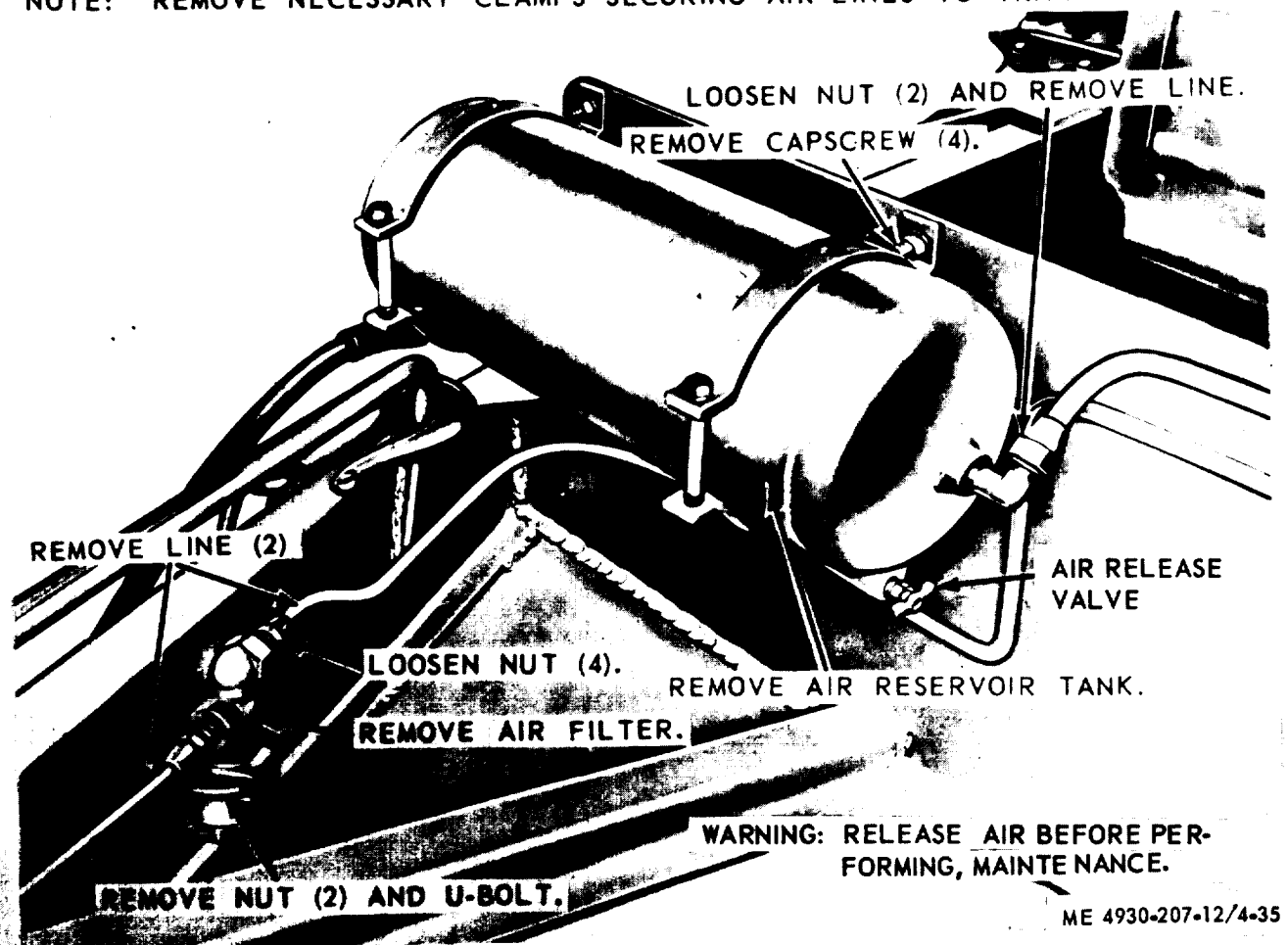

Figure 4-35. Air receiver and air filter, removal and installation.

(2) Repair by replacement of defective parts.

c. *Installation.* Install the air reservoir as illustrated in figure 4-35.

Section X. TRAILER FRAME

4-49. General

This section consists of maintenance for the landing gear, shock absorbers, springs and spring hangers, fenders, and wheel chocks. The shock absorbers are of the two way control type, double acting, hydraulic cylinder units.

4-50. Landing Gear and Lunette

a. *Removal.* Remove the landing gear and lunette as illustrated in figure 4-36.

b. *Disassembly.* Disassemble the landing gear in numerical sequence as illustrated in figure 4-37.

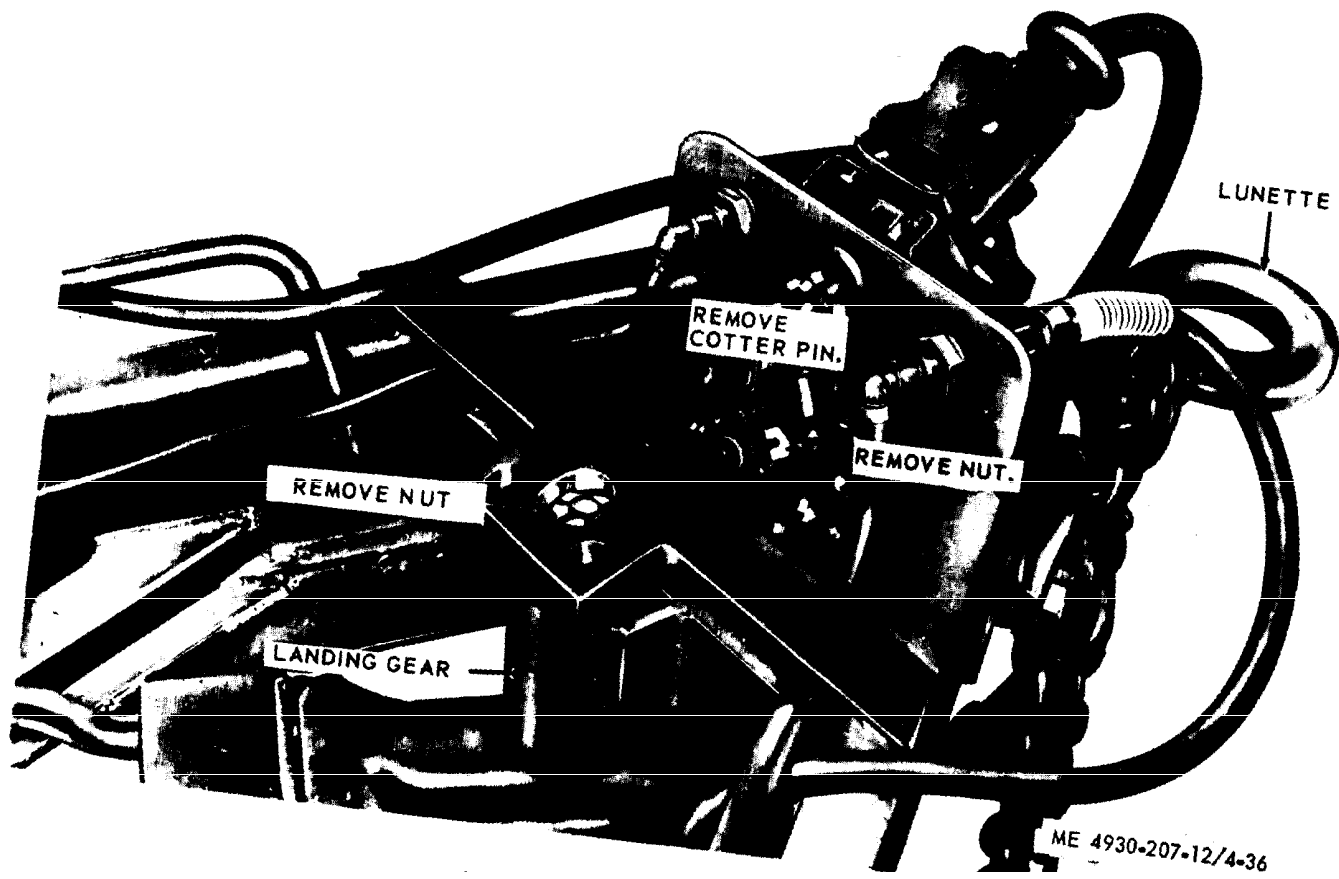

*Figure 4-36. Landing gear and lunette,
removal and installation.*

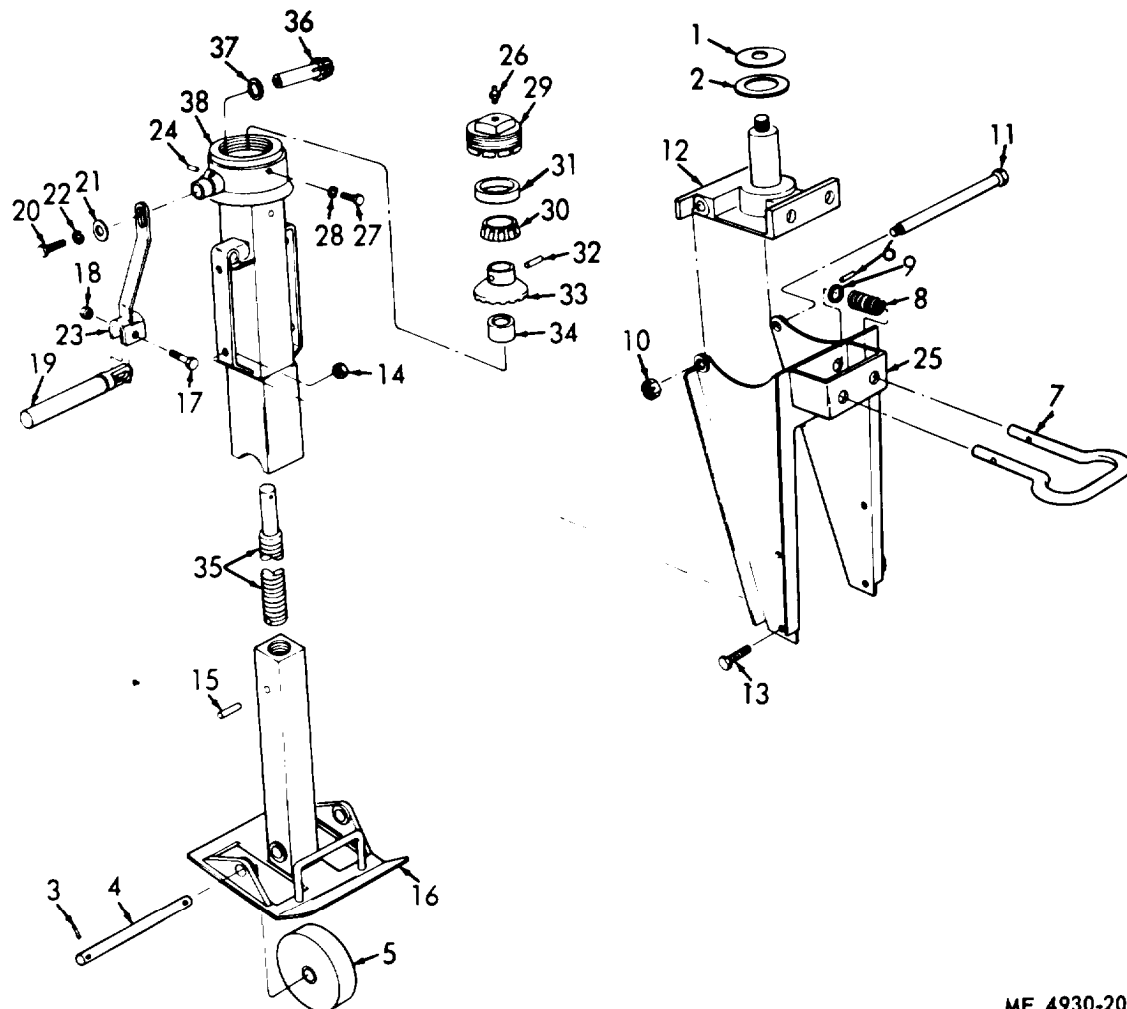

- | | |
|-------------------------|-------------------------|
| 1 Cap lockwasher | 20 Machine bolt |
| 2 Plain washer | 21 Flatwasher |
| 3 Straight headless pin | 22 Lockwasher |
| 4 Leveling jack axle | 23 Crank arm assembly |
| 5 Landing gear wheel | 24 Headless grooved pin |
| 6 Straight headless pin | 25 Leg frame assembly |
| 7 Support handle | 26 Lubrication fitting |
| 8 Compression spring | 27 Hex head capscrew |
| 9 Recessed washer | 28 Lockwasher |
| 10 Self locking nut | 29 Head cap |
| 11 Shoulder bolt | 30 Bearing cup |
| 12 Swivel bracket | 31 Bearing cone |
| 13 Machine bolt | 32 Grooved pin |
| 14 Self locking nut | 33 Bevel gear |
| 15 Grooved pin | 34 Screw spacer |
| 16 Inner tube assembly | 35 Leveling screw shaft |
| 17 Hex head capscrew | 36 Bevel gear |
| 18 Plain hex nut | 37 Ring spacer |
| 19 Crank arm handle | 38 Outer tube assembly |

ME 4930-207-12/4-37

Figure 4-37. Landing gear, disassembly and reassembly

c. Inspection and Repair.

(1) Inspect all parts for cracks, breaks or other damage.

(2) Repair by replacement of defective parts.

d. Reassembly. Reassemble the landing gear in the reverse of numerical sequence as illustrated in figure 4-37.

e. Installation. Install the landing gear assembly and lunette as illustrated in figure 4-36.

4-51. Shock Absorbers

a. Removal. Remove the trailer shock absorbers as illustrated in figure 4-38.

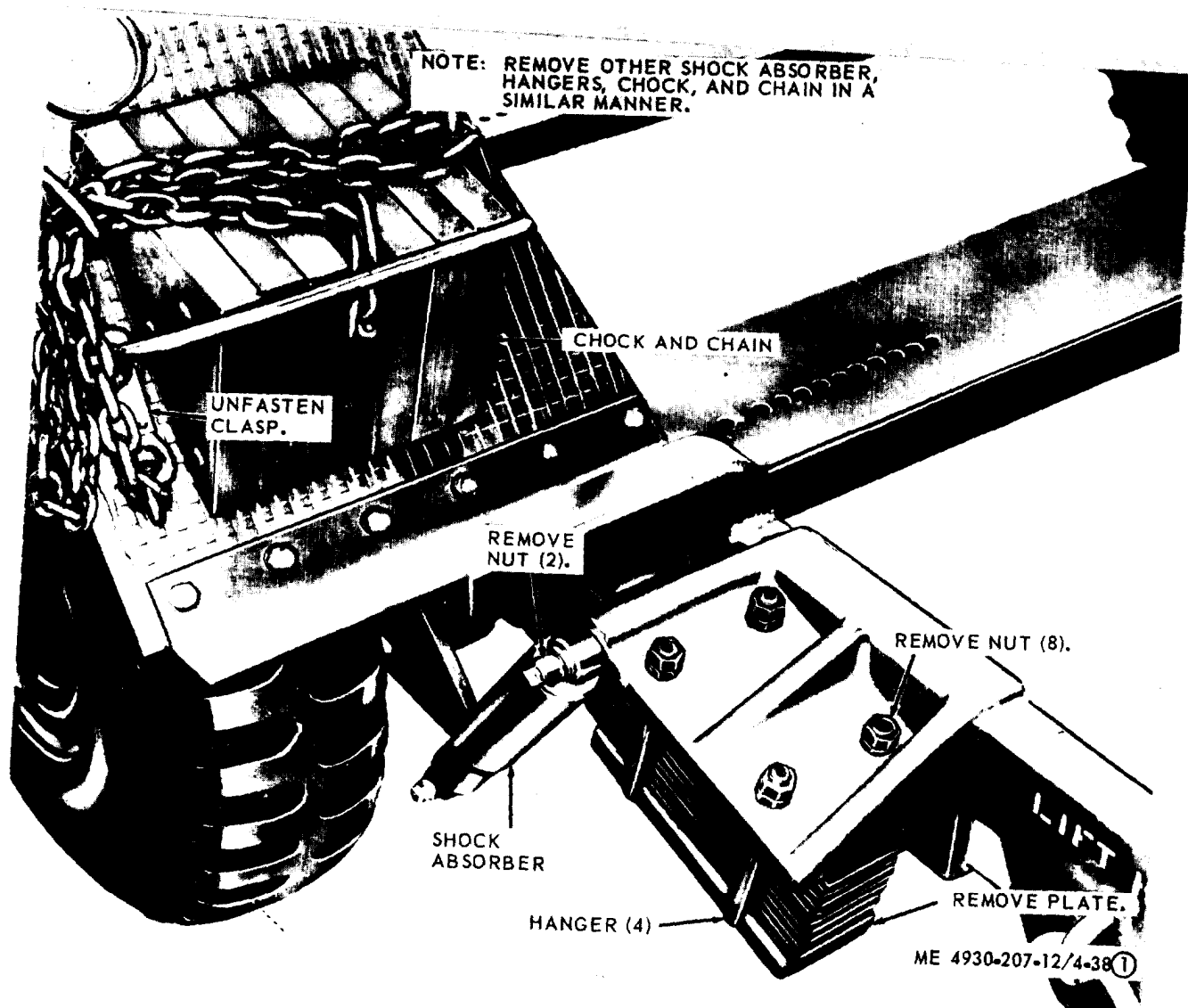

Figure 4-38. Trailer suspension system and wheel chocks, removal and installation (sheet 1 of 2).

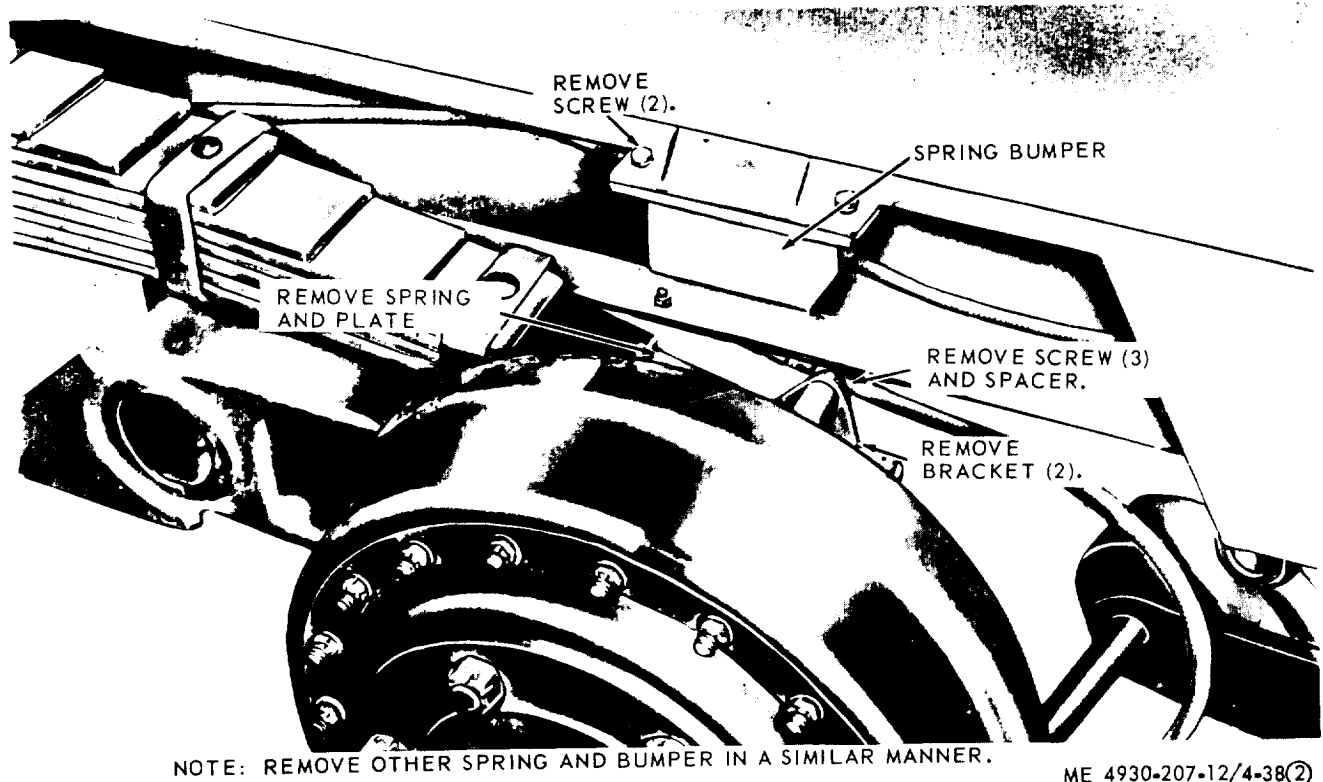

Figure 4-38. Trailer suspension system and wheel chocks, removal and installation(sheet 2 of 2).

b. Inspection and Repair.

(1) Inspect shock absorbers for proper operation or damage.

(2) Replace a defective shock absorber.

c. Installation. Install the shock absorbers as illustrated in figure 4-38.

4-52. Springs and Spring Hangers

a. Removal. Remove the shock absorbers, springs and spring hangers as illustrated in figure 4-38.

b. Inspection and Repair.

(1) Clean springs and check each leaf for cracks or breaks.

(2) Inspect spring hangers for cracks, breaks, or other damage.

(3) Repair by replacement of all defective parts.

c. Installation. Install the springs, spring hangers and shock absorbers as illustrated in figure 4-38.

4-53. Spring Bumpers

a. Removal. Remove the spring bumper as illustrated in figure 4-38.

b. Installation. Install the spring bumpers as illustrated in figure 4-38.

4-54. Wheel Chocks

a. Removal. Remove the wheel chocks as illustrated in figure 4-38.

b. Installation. Install the wheel chocks as illustrated in figure 4-38.

4-55. Fenders

a. Removal.

(1) Remove the clearance lights (para 4-13).

(2) Remove the wheel chocks (para 4-51).

(3) Remove the fender as illustrated in figure 4-39.

NOTE: REMOVE OTHER FENDER
IN A SIMILAR MANNER.

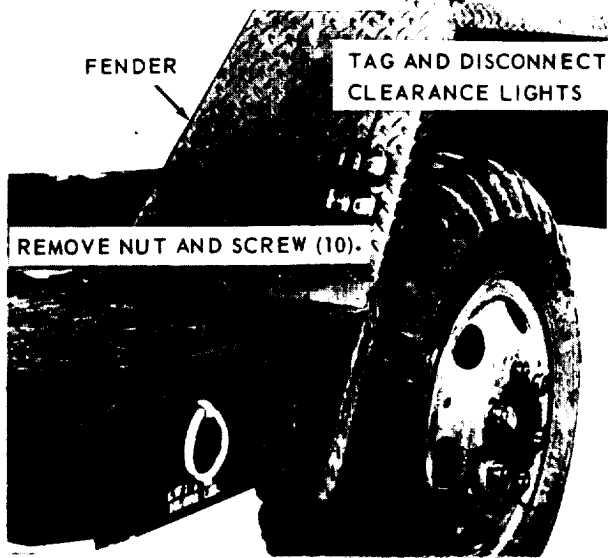

b. *Installation.* Install the fenders as illustrated in figure 439.

4-56. Safety Chain

a. *Removal.* Remove the trailer safety chains as illustrated in figure 4-40.

b. *Installation.* Install the safety chains as illustrated in figure 4-40.

Figure 4-39. Fender, removal and installation.

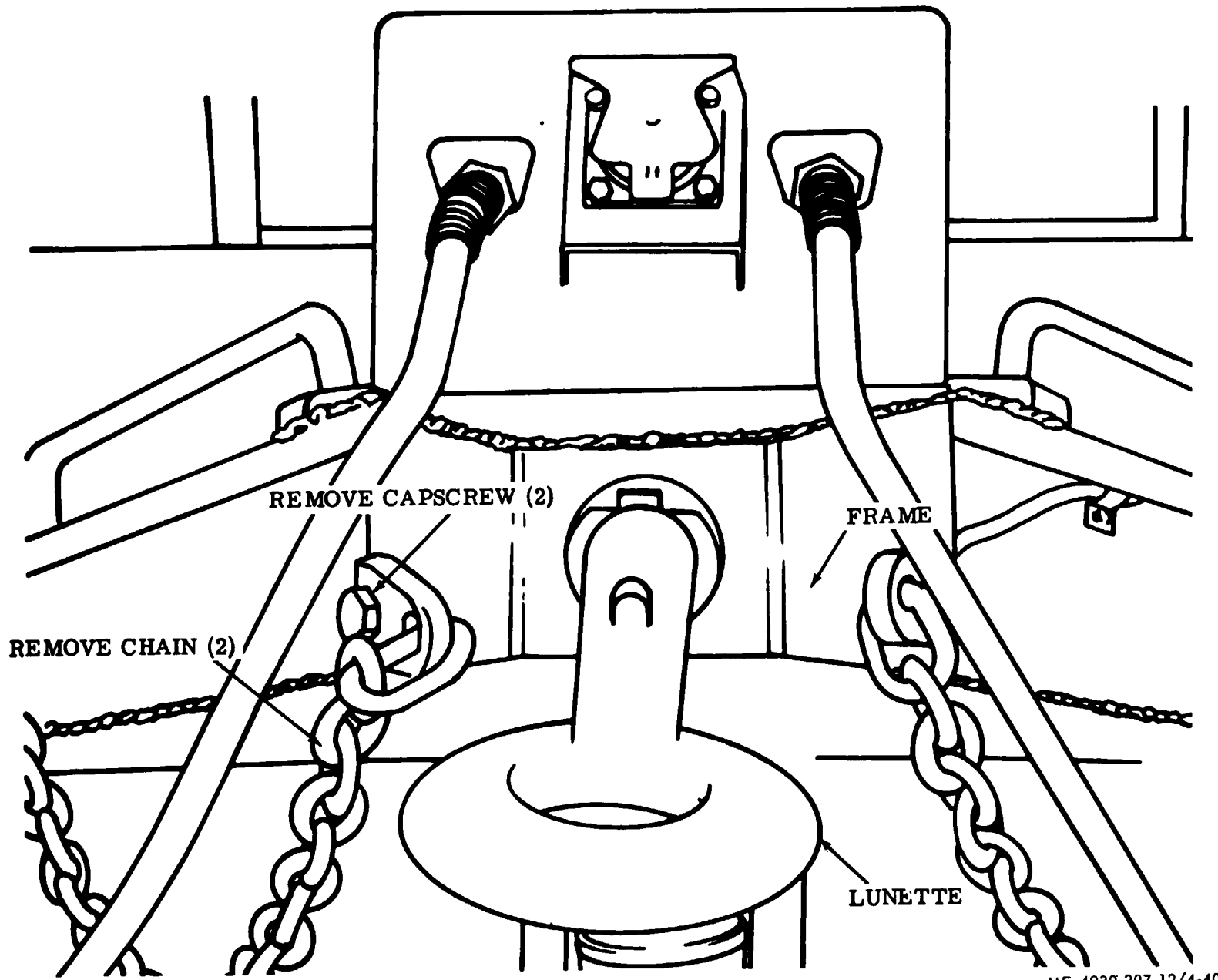

ME 4930-207-12/4-40

Figure 4-40. Safety chain, removal and installation.

APPENDIX A REFERENCES

A-1. Fire Protection

TB 5-4200-200-10 Hand Portable Fire Extinguishers for Army Users

A-2. Lubrication

C9100IL Fuels, Lubricants, Oils and Waxes
LO 5-4930-207-12 Lubrication Order, Lubricating and Servicing Unit, Power Operated, Trailer Mounted, 23 cfm Compressor, Reciprocating, Gasoline Engine Driven (Henry Spen Model 901765-1)
LO 5-2805-203-14 Lubrication Order, Engine, Gasoline, Military Standard Model (4A0321 and 4A03211)
LO 5-2330-216-15 Lubrication Order, Chassis, Trailer; 2½ Ton; Drop Axle; 2 Wheel, Eng. Dwg. D132112E3636

A-3. Painting

TM 9-213 Painting Instructions for Field Use

A-4. Radio Suppression

TM 11-483 Radio Interference Suppression

A-5. Maintenance

TM 9-1870-1 Care and Maintenance of Pneumatic Tires
TM 38-750 Army Equipment Record Procedures
TM 5-2805-203-14 Operator's Organizational, Direct Support and General Support Maintenance Manual, Engine Gasoline, Military Standard Models 4A032I and 4A032II
TM 5-4930-207-20P Organizational Maintenance Repair Parts and Special Tool List, Lubricating and Servicing Unit, Power Operated, Trailer Mounted, 23 cfm, Compressor, Reciprocating, Gasoline Driven (Henry Spen Model 901765-1)
TM 5-2805-203-24P Organizational Direct Support and General Support Maintenance Repair Parts and Special Tool List, Engine, Gasoline, Military Standard Models 4A0321 and 4A03211
TM 9-6140-200-15 Operation and Organizational Field and Depot Maintenance Storage Batteries, Lead Acid Type

A-6. Shipment and Storage

TB 740-93-2 Preservation of USAMEC Mechanical Equipment for Shipment and Storage
TM 740-90-1 Administrative Storage of Equipment

A-7. Demolition

TM 750-244-3 Procedures for Destruction of Equipment to Prevent Enemy Use

APPENDIX B

MAINTENANCE ALLOCATION CHART

Section I. INTRODUCTION

B-1. General

a. This section provides a general explanation of all maintenance and repair functions authorized at various maintenance levels.

b. Section II designates overall responsibility for the performance of maintenance functions on the identified end item or component. The implementation of the maintenance functions upon the end item or component will be consistent with the assigned maintenance functions.

c. Section III lists the special tools and test equipment required for each maintenance function as referenced from Section II.

d. Section IV contains supplemental instructions, explanatory notes and/or illustrations required for a particular maintenance function

B-2. Explanation of Columns in Section II

a. *Group Number, Column (1)*. The assembly group is a numerical group assigned to each assembly in a top down breakdown sequence. The applicable assembly groups are listed on the MAC in disassembly sequence beginning with the first assembly removed in a top down disassembly sequence.

b. *Functional Group, Column (2)*. This column contains a brief description of the components of each assembly group.

c. *Maintenance Functions, Column (3)*. This column lists the various maintenance functions (A through K) and indicates the lowest maintenance category authorized to perform these functions. The symbol designations for the various maintenance categories are as follows:

- C — Operator or crew
- O — Organizational maintenance
- F — Direct support maintenance
- H — General support maintenance

The maintenance functions are defined as follows:

A — Inspect: To determine serviceability of an item by comparing its physical, mechanical, and electrical characteristics with established standards.

B — Test: To verify serviceability and to detect electrical or mechanical failure by use of test equipment.

C — Service: To clean, to preserve, to charge, and to add fuel, lubricants, cooling agents, and air. If it

is desired that elements, such as painting and lubricating, be defined separately, they may be so listed.

D — Adjust: To rectify to the extent necessary to bring into proper operating range.

D — Aline: To adjust specified variable elements of an item to bring to optimum performance.

F — Calibrate: To determine the corrections to be made in the readings of instruments or test equipment used in precise measurement. Consists of the comparison of two instruments, one of which is a certified standard of known accuracy, to detect and adjust any discrepancy in the accuracy of the instrument being compared with the certified standard.

G — Install: To set up for use in an operational environment such as an emplacement, site, or vehicle.

H — Replace: To replace unserviceable items with serviceable like items.

I — Repair: Those maintenance operations necessary to restore an item to serviceable condition through correction of material damage or a specific failure. Repair may be accomplished at each category of maintenance.

J — Overhaul: Normally, the highest degree of maintenance performed by the Army in order to minimize time work in process is consistent with quality and economy of operation. It consists of that maintenance necessary to restore an item to completely serviceable condition as prescribed by maintenance standards in technical publications for each item of equipment. Overhaul normally does not return an item to like new, zero mileage, or zero hour condition.

K — Rebuild: The highest degree of materiel maintenance. It consists of restoring equipment as nearly as possible to new condition in accordance with original manufacturing standards. Rebuild is performed only when required by operational considerations or other paramount factors and then only at the depot maintenance category. Rebuilt reduces to zero the hours or miles the equipment, or component thereof, has been in use.

d. *Tools and Equipment, Column (4)*. This column is provided for referencing by code the special tools and test equipment (see III), required to perform the maintenance functions (see II).

e. *Remarks, Column (5)*. This column is provided

(1) Group No.	(2) Functional group	(3) Maintenance functions											(4) Tools and equipment	(5) Remarks				
		A	B	C	D	E	F	G	H	I	J	K						
		Inspect	Test	Service	Adjust	Align	Calibrate	Install	Replace	Repair	Overhaul	Rebuild						
09	Clutch, friction	O		O					O									
	Switch, by-pass	C							O									
	Generator assembly	O			O				O	F								B
	Starter assembly	O			O				O	F								C
10	Air Receiver and Alcohol Dispenser																	
	Hose, lines and fittings	C		O					O									
	Receiver, air Dispenser, alcohol			O					O	O								
11	Lubrication Pumps, Valves and Tank Covers																	
	Hose, pipe and fittings	C		C					O									
	Valve, regulating Pump assembly			C					O	O								E
12	Trailer Lights and Wiring Harness																	
	Lights								O	O								
	Wiring harness	O							O	O								
13	Tires and Wheels																	
	Tires			C					O									
	Tubes								O	O								
	Brake System, Air and Hydraulic																	
14	Reservoir, air			C					O									
	Air filter			C					O	F								
	Air chamber								O	O								
	Master cylinder assembly			C					O	F								D
15	Wheel Hub and Service Brakes																	
	Bearings			O					O									
	Brake assembly				O				F	F								
	Brake shoe								O	F								
16	Wheel cylinder assembly								O	F								
	Shock Absorbers, Axle and Springs																	
	Axle assembly								F	F								
17	Axle bearings			O					F									
	Wheel Chocks, Coupler and Rear Support Assembly																	
17	Support assembly, rear								O	O								
	Trailer Frame and Fenders																	
17	Trailer frame								H	H								

Section III. SPECIAL TOOL AND SPECIAL TEST EQUIPMENT REQUIREMENTS

Reference code	Maintenance level	Nomenclature	Tool number
No special tools or test equipment is required to perform maintenance on the Lubricating and Servicing Unit.			

Section IV. REMARKS

Reference Code	Remarks
A-B	For maintenance allocation chart relative to the military.
A-1	Mil Standard engine model 4A032-I and II, refer to TM 5-2805-203-14
B-I	Repair of generator includes replacing bearings.
C-I	Repair of starter includes installing repair kit.
D-1	Repair of master cylinder includes installing repair kit.
E-I	Repair of pump includes installing repair kit.

**APPENDIX C
BASIC ISSUE ITEMS LIST**

Section I. INTRODUCTION

C-1. Scope

This appendix lists items which accompany the lubricating and servicing unit or are required for installation, operation, or operator's maintenance.

C-2. General

This Basic Issue Items List is divided into the following sections:

a. Basic Issue Items — Section II. A list of items which accompany the lubricating and servicing unit and are required by the operator/crew for installation, operation, or maintenance.

b. Maintenance and Operating Supplies — Section III. A listing of maintenance and operating supplies required for initial operation.

C-3. Explanation of Columns

The following provides an explanation of columns in the tabular list of Basic Issue Items, Section 11.

a. Source, Maintenance, and Recoverability Codes (SMR).

(1) Source code, indicates the source for the listed item. Source code is:

Code	Explanation
P	Repair parts which are stocked in or supplied from the GSA/DSA, or Army supply system and authorized for use at indicated maintenance categories.

(2) Maintenance code indicates the lowest category of maintenance authorized to install the listed item. The maintenance level code is:

Code	Explanation
c	Operator/crew

b. Federal Stock Number. This column indicates the Federal stock number assigned to the item and will be used for requisitioning purposes.

c. Description. This column indicates the Federal item name and any additional description of the item required. The abbreviation "w/e", when used as a part of the nomenclature, indicates the Federal stock number, includes all armament, equipment, accessories, and repair parts issued with the item, A part number or other reference number is followed by the applicable five-digit Federal supply code for manufacturers in parenthesis. Repair parts quantities included in kits, sets, and assemblies are shown in front of the repair part name.

d. Unit of Measure (U/M). A two-character alphabetic abbreviation indicating the amount or quantity of the item upon which the allowances are based, e.g., ft, ea, pr, etc.

e. Quantity Incorporated in Unit. This column indicates the quantity of the item used in the assembly group. A "V" appearing in this column in lieu of a quantity indicates that a definite quantity cannot be indicated (e.g., shims, spacer, etc.).

f. Quantity Furnished With Equipment. This column indicates the quantity of an item furnished with the equipment.

g. Illustration. This column is divided as follows:

(1) *Figure number.* Indicates the figure number of the illustration in which the item is shown.

(2) *Item number.* Indicates the callout number used to reference the item in the illustration.

C-4. Explanation of Columns in the Tabular List of Maintenance and Operating Supplies — Section III

a. Component Application. This column identifies the component application of each maintenance or operating supply item.

b. Federal Stock Number. This column indicates the Federal stock number assigned to the item and will be used for requisitioning purposes.

c. Description. This column indicates the item name and brief description.

d. Quantity Required for Initial Operation. This column indicates the quantity of each maintenance or operating supply item required for initial operation of the equipment.

e. Quantity Required for Eight Hours Operation This column indicates the estimated quantities required for an average 8 hours of operation.

f. Notes. This column indicates informative notes keyed to data appearing in a preceding column.

C-5. Abbreviations

ea	each
gal	gallon
in.	inches
lb	pounds
lg	long
NPT	National Pipe Thread
qt	quarts

Section II. BASIC ISSUE ITEMS

(1) SMR Code	(2) Federal Stock Number	(3) Description Ref No. & Mfr Code	(4) unit of Meas Usable on code	(5) Qty Inc in Unit	(6) Qty Furn with Equip	(7) Illustrations	
						(A) Fig No.	(B) Item No.
PC	7510-889-3494	Group 01 – ACCESSORIES					
		BINDER, LOOSE-LEAF: U. S. Army Equipment Log Book	EA	1	1		
PC	7520-559-9618	CASE: Maintenance and Operational Manuals, Cotton Duck, Water Repellent, Mildew Resistant, MIL-B-11743	EA	1	1		
		Group 02 – PUBLICATIONS					
		DEPARTMENT OF THE ARMY LUBRICATION ORDER, LO 5-2330-216-15	EA	1	1		
		DEPARTMENT OF THE ARMY LUBRICATION ORDER, LO 5-2805-203-14	EA	1	1		
		DEPARTMENT OF THE ARMY LUBRICATION ORDER, LO 5-4930-207-12	EA	1	1		
		DEPARTMENT OF THE ARMY ORGANIZATIONAL AND FIELD MAINTENANCE REPAIR PARTS AND SPECIAL TOOL LISTS, TM 5-2805-203-24P	EA	2	2		
		DEPARTMENT OF THE ARMY OPERATOR, ORGANIZATIONAL AND FIELD MAINTENANCE MANUAL. TM 5-2805-203-14	EA	2	2		
		DEPARTMENT OF THE ARMY OPERATOR AND ORGANIZATIONAL MAINTENANCE REPAIR PARTS MANUAL, TM 5-4930-207-20P	EA	2	2		
		DEPARTMENT OF THE ARMY OPERATOR AND ORGANIZATIONAL MAINTENANCE MANUAL, TM 5-4930-207-12	EA	2	2		

Section III. MAINTENANCE AND OPERATING SUPPLIES

(1) Component application	(2) Federal Stock number	(3) Description	(4) Quantity required /initial operation	(5) Quantity required /8 hrs operation	(6) Notes
FUEL TANK	9130-160-1818	FUEL, GASOLINE: Bulk as follows: Automotive combat, type I	10 gal (4)	(5)	(1) Includes quantity of oil to fill compressor oil system as follows: 2 qt. compressor (2) See FSC C9100-IL for additional data and requisitioning procedures. (3) See current lubrication chart for grade application and replenishment intervals. (4) Tank capacity. (5) See TM 5-2805-203-14 for average fuel consumption. (6) Quantity of oil to fill oil reservoir. (7) Quantity of gear oil to fill reservoir (8) 2 ea — 100-lb. drums are required to fill grease reservoir.
ALCOHOL DISPENSER	9130-160-1830	Automotive, combat, type II ALCOHOL, DENATURED: 1 qt. botl	10 gal (4)	(5)	
CRANKCASE	6810-264-6583	as follows: Alcohol	¼ qt		
	9150-265-9437 (2)	OIL, LUBRICATING: 55 gal. drum as follows: OE-30	2 qt	(3)	
	9150-265-9430 (2)	OE-10	2 qt	(3)	
	9150-242-7605 (2)	OES	2 qt	(3)	
LUBRICATING OIL RESERVOIR	9150-265-9437 (2)	OIL, LUBRICATING: 55 gal. drum as follows: OE-30	27 gal	(6)	
	9150-265-9430 (2)	OE-10	27 gal	(6)	
	9150-242-7605 (2)	OES	27 gal	(6)	
LUBRICATING GEAR OIL RESERVOIR	9150-577-5846 (2)	LUBRICATING OIL, GEAR: 55 gal. drum as follows: GO-90	27 gal	(7)	
	9150-257-5443 (2)	COS	27 gal	(7)	
LUBRICATING GREASE RESERVOIR	9150-530-7369	GREASE, AUTOMOTIVE AND ARTILLERY: 120 lb. drum as follows: GAA	175 lb.	(8)	

ALPHABETICAL INDEX

Subject	A	Paragraph, Figure, Table, Number
Accessory drawer	4-8	4-5
Accessory equipment	2-27	2-24
Adjustment:		
Brakes	4-42	4-41
Compressor drive belt	3-17	3-5
Generator drive belt	3-16	3-4
Air blower gun operation	2-26	2-24
Air brake chamber	4-45	4-45
Air brake filter service	3-19	3-7
Air brake reservoir service	3-19	3-7
Aircleaner, service (aircompressor)	3-18	3-6
Air compressor	4-27	4-22
Air compressor drive pulley	4-23	4-18
Air filter, brakes	4-47	4-46
Air hoses	4-33	4-28
Air regulating valve	4-29	4-22
Air relief valve	4-25	4-21
Air reservoir	4-48	4-46
Alcohol dispenser:		
Repair	4-35	4-32
Service	3-15	3-4
B		
Basic issue tools and equipment	3-2	3-1
Batteries, service	3-14	3-4
Battery and battery drawer	4-7	4-5
Bleeding brakes	4-42	4-41
Brake air filter, service	3-19	3-7
Brake bleeding	4-42	4-41
Brake drum	4-41	4-39
Brake shoes	4-43	4-42
Bumpers, spring	4-53	4-51
C		
Chain, trailer safety	4-56	4-52
Chamber, air brake	4-45	4-45
Cleaner, engine air	3-11	3-4
Clearance lights	4-17	4-11
Clutch assembly	4-37	4-35
Compressor air	4-27	4-22
Compressor air cleaner service	3-18	3-6
Compressor drive belt adjustment	3-17	3-5
Control and instruments	2-8	2-4
Covers, lubricant tanks	4-31	4-25
Cylinder, master	4-44	4-44
Cylinder, wheel	4-43	4-42
D		
Description	1-4	1-1
Detailed lubrication information	3-5	3-1
Difference in models	1-5	1-10
Dismantling for movement	2-5	2-4
Dispenser, alcohol:		
Repair	4-35	4-32
Service	3-15	3-4
Dispensing lubricant	2-15	2-15
Diverter, exhaust	4-21	4-17
Drawer, accessory	4-8	4-5
Drawer, battery	4-7	4-5
Drum, brake	4-41	4-39

Subject	Paragraph, Figure, Table,Number
E	
Emergency relay valve	4-46 4-46
Emergency assembly	4-6 4-4
Engine air cleaner	3-2
Engine assembly	4-38 4-36
Engine oil filter	3-12 3-4
Equipment operation	2-13 2-10
Extinguisher, fire	2-29 2-26
F	
Fenders	4-55 4-51
Filling lubricant tanks	2-13 2-10
Filter, air brakes	4-47 4-46
Filter, engine oil	3-12 3-4
Filter, fuel:	
Repair	4-20 4-15
Service	3-13 3-4
Fire extinguisher	2-29 2-26
Forms and Records	1-3 1-1
Fuel filter	
<i>Repair</i>	4-20 4-15
<i>Service</i>	3-13 3-4
Fuel lines	4-20 4-15
Fuel tank	4-20 4-15
Gages, instrument panel	4-16 4-9
(Gear, trailer, landing	4-50 4-47
General lubrication information	3-4 3-1
(Generator	4-11 4-7
(Generator drive belt adjustment	3-16 3-4
Gun, air blower, operation	2-26 2-24
Gun, hand, operation	2-24 2-23
Gun, oil, spray, operation	2-25 2-24
H	
Hand gun operation	2-24 2-23
Hangers, trailer springs	4-52 4-51
Harness, wiring	4-18 4-12
High oil temperature switch	4-14 4-9
Hoses, air	4-24 4-19
Hoses, lubricant and air	4-23 4-18
Hose reel	4-34 4-30
Hub, wheel	4-41 4-39
I	
Identification and tabulated data	1-5 1-7
Inspection and servicing equipment	2-2 2-3
Installation of separately packed components	2-3 2-3
Installation or setting up instructions	2-4 2-4
Instrumental and controls	2-8 2-4
Instrument panel	4-16 4-9
L	
Landing gear	4-50 4-47
Lights, clearance	4-17 4-11
Light, trouble	4-10 4-6
Lines, air	4-24 4-19
Lines, fuel	4-20 4-15
Low oil pressure switch	4-13 4-8
Lubricant dispensing	2-15 2-15
Lubricant hoses	4-33 4-28
Lubricant pump	4-30 4-24
Lubrication information	3-6 3-1
Lubricator, portable	2-28 2-24
Lubricant pump, preparation for operation	2-14 2-12
Lunette	4-50 4-47

Subject	Paragraph, Figure Table, Number
M	
Master cylinder	4-44 4-44
Meters, lubricant	4-32 4-26
Motor, starting.	4-12 4-8
Oil pressure transmitter	4-15 4-9
Oil spray gun operation	2-25 2-24
Operation at high altitude	2-22 2-22
operation in dusty or sandy areas	2-19 2-22
Operation in extreme cold	2-17 2-21
Operation in extreme heat	2-18 2-22
Operation in rainy or humid conditions.	2-20 2-22
Operation in salt water areas	2-21 2-22
Operation of equipment	2-13 2-10
Organizational maintenance repair parts	3-3 3-1
P	
Panel instrument	4-16 4-9
Pilot valve	4-26 4-21
Portable lubricate	2-32
Preparing lubricant pumps for operation	2-14 2-12
Preventive maintenance services	3-7 3-1
Pulley, compressor drive	4-23 4-18
Pumps, lubricant	4-30 4-24
R	
Record and report forms	1-3 1-1
Reel, hose	4-34 4-30
Regulator, voltage	4-11 4-7
Reinstallation after movement.	2-6 2-4
Reservoir, air	4-48 4-46
Reservoir, air brake service	3-17 3-5
S	
Scope	1-1 1-1
Safety chain	4-56 4-42
Servicing equipment.	2-2 2-3
Setting up instructions	2-4 2-4
Shock absorbers	4-51 4-49
Shoe, brake	4-43 4-42
Shutdown procedure	2-16 2-15
Special tools and equipment	3-1 3-1
Spring bumpers	4-53 4-51
Springs, trailer.	4-52 4-52
Starting engine	2-10 2-8
Starting motor	4-12 4-8
Stopping engine	2-11 2-9
Switch, high oil temperature	4-14 4-9
Switches, instrument panel	4-16 4-9
Switch, low oil pressure.	4-13 4-8
T	
Tabulated data	1-5 1-7
Taillight.	4-18 4-12
Tank, fuel	4-20 4-15
Tires and wheels.	4-40 4-37
Tools and equipment	3-1 3-1
Tool box	4-8 4-5
Transmitter, oil pressure	4-15 4-9
Trouble light	4-10 4-6
Troubleshooting.	3-9 3-2
U	
Unloading equipment	2-1 2-1
V	
Valve, air regulating	4-29 4-22
Valve, brake relay emergency	4-46 4-46
Valve, air relief	4-25 4-21
Valve, exhaust diverter	4-21 4-17

Subject	Paragraph, Figure, Table, Number	
Valves, lubricant	4-32	4-26
Valve, pilot	4-26	4-21
Voltage regulator	4-11	4-7
W		
Wheels and tires	4-40	4-37
Wheel chocks	4-54	4-51
Wheel cylinder	4-43	4-42
Wiring harness	4-18	4-12

By Order of the Secretary of the Army:

W. C. WESTMORELAND,
General, United States Army,
Chief of Staff

Official:

KENNETH G. WICKHAM,
Major General, United States Army,
The Adjutant General.

Distribution:

To be distributed in accordance with DA Form 12-25, Section I, (qty rqr block no. 137) operator maintenance requirements for Equipment: Lubricating & Servicing.

*U.S. GOVERNMENT PRINTING OFFICE: 1970-397095/5177

RECOMMENDED CHANGES TO EQUIPMENT TECHNICAL PUBLICATIONS



THEN...JOT DOWN THE DOPE ABOUT IT ON THIS FORM. CAREFULLY TEAR IT OUT, FOLD IT AND DROP IT IN THE MAIL.

SOMETHING WRONG WITH PUBLICATION

FROM: (PRINT YOUR UNIT'S COMPLETE ADDRESS)

DATE SENT

PUBLICATION NUMBER

PUBLICATION DATE

PUBLICATION TITLE

BE EXACT PIN-POINT WHERE IT IS

PAGE NO.

PARA-GRAPH

FIGURE NO.

TABLE NO.

IN THIS SPACE, TELL WHAT IS WRONG AND WHAT SHOULD BE DONE ABOUT IT.

TEAR ALONG PERFORATED LINE

PRINTED NAME, GRADE OR TITLE AND TELEPHONE NUMBER

SIGN HERE

THE METRIC SYSTEM AND EQUIVALENTS

WEIGHT MEASURE

1 Centimeter = 10 Millimeters = 0.01 Meters = 0.3937 Inches
 1 Meter = 100 Centimeters = 1000 Millimeters = 39.37 Inches
 1 Kilometer = 1000 Meters = 0.621 Miles

WEIGHTS

1 Gram = 0.001 Kilograms = 1000 Milligrams = 0.035 Ounces
 1 Kilogram = 1000 Grams = 2.2 lb.
 1 Metric Ton = 1000 Kilograms = 1 Megagram = 1.1 Short Tons

LIQUID MEASURE

1 Milliliter = 0.001 Liters = 0.0338 Fluid Ounces
 1 Liter = 1000 Milliliters = 33.82 Fluid Ounces

SQUARE MEASURE

1 Sq. Centimeter = 100 Sq. Millimeters = 0.155 Sq. Inches
 1 Sq. Meter = 10,000 Sq. Centimeters = 10.76 Sq. Feet
 1 Sq. Kilometer = 1,000,000 Sq. Meters = 0.386 Sq. Miles

CUBIC MEASURE

1 Cu. Centimeter = 1000 Cu. Millimeters = 0.06 Cu. Inches
 1 Cu. Meter = 1,000,000 Cu. Centimeters = 35.31 Cu. Feet

TEMPERATURE

$5/9(^{\circ}\text{F} - 32) = ^{\circ}\text{C}$
 212° Fahrenheit is equivalent to 100° Celsius
 90° Fahrenheit is equivalent to 32.2° Celsius
 32° Fahrenheit is equivalent to 0° Celsius
 $9/5^{\circ}\text{C} + 32 = ^{\circ}\text{F}$

APPROXIMATE CONVERSION FACTORS

TO CHANGE	TO	MULTIPLY BY
Inches	Centimeters	2.540
Feet	Meters	0.305
Yards	Meters	0.914
Miles	Kilometers	1.609
Square Inches	Square Centimeters	6.451
Square Feet	Square Meters	0.093
Square Yards	Square Meters	0.836
Square Miles	Square Kilometers	2.590
Acres	Square Hectometers	0.405
Cubic Feet	Cubic Meters	0.028
Cubic Yards	Cubic Meters	0.765
Fluid Ounces	Milliliters	29.573
its	Liters	0.473
arts	Liters	0.946
allons	Liters	3.785
Ounces	Grams	28.349
Pounds	Kilograms	0.454
Short Tons	Metric Tons	0.907
Pound-Feet	Newton-Meters	1.356
Pounds per Square Inch	Kilopascals	6.895
Miles per Gallon	Kilometers per Liter	0.425
Miles per Hour	Kilometers per Hour	1.609

TO CHANGE	TO	MULTIPLY BY
Centimeters	Inches	0.394
Meters	Feet	3.280
Meters	Yards	1.094
Kilometers	Miles	0.621
Square Centimeters	Square Inches	0.155
Square Meters	Square Feet	10.764
Square Meters	Square Yards	1.196
Square Kilometers	Square Miles	0.386
Square Hectometers	Acres	2.471
Cubic Meters	Cubic Feet	35.315
Cubic Meters	Cubic Yards	1.308
Milliliters	Fluid Ounces	0.034
Liters	Pints	2.113
Liters	Quarts	1.057
ers	Gallons	0.264
ms	Ounces	0.035
ograms	Pounds	2.205
Metric Tons	Short Tons	1.102
Newton-Meters	Pounds-Feet	0.738
Kilopascals	Pounds per Square Inch	0.145
ometers per Liter	Miles per Gallon	2.354
ometers per Hour	Miles per Hour	0.621

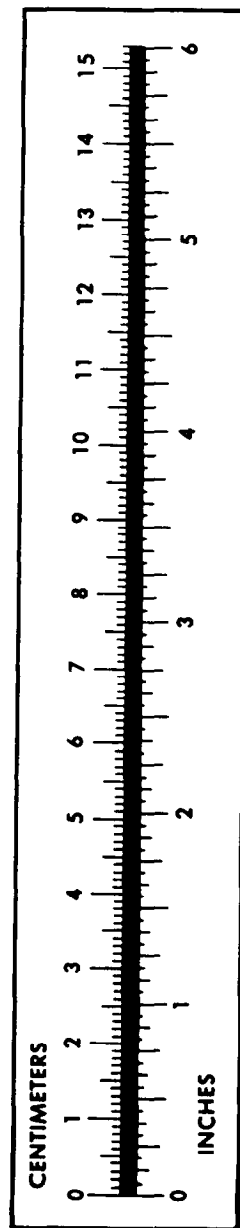

PIN: 005948-000