

TM 5-4930-207-34

DEPARTMENT OF THE ARMY TECHNICAL MANUAL

DIRECT SUPPORT AND GENERAL SUPPORT
MAINTENANCE MANUAL

LUBRICATING AND SERVICING UNIT, POWER

OPERATED: TRAILER MOUNTED 23 CFM

COMPRESSOR RECIPROCATING, GASOLINE DRIVEN

(HENRY SPEN MODEL 901765-1)

FSN 4930-017-9167

HEADQUARTERS, DEPARTMENT OF THE ARMY

22 APRIL 1970

WARNING

AIR UNDER PRESSURE 175 PSI

AIR PRESSURE

is used in the operation of this equipment.

DEATH

or severe injury may result if personnel fail to observe safety precautions.

**DIRECT SUPPORT AND GENERAL SUPPORT
 MAINTENANCE MANUAL**

**LUBRICATING AND SERVICING UNIT, POWER
 OPERATED: TRAILER MOUNTED 23 CFM
 COMPRESSOR RECIPROCATING, GASOLINE DRIVEN
 (HENRY SPEN MODEL 901765-1)
 FSN 4930-017-9167**

		Paragraph	Page
	LIST OF ILLUSTRATIONS		ii
CHAPTER	1. INTRODUCTION		
Section	I. General	1-1, 1-2	1-1
	II. Description and data	1-3-1-5	1-1
CHAPTER	2. DIRECT SUPPORT AND GENERAL SUPPORT MAINTENANCE INSTRUCTIONS		
Section	I. Repair parts, special tools and equipment	2-1-2-3	2-1
	II. Troubleshooting	2-4	2-1
	III. Removal and installation of major components and auxiliaries	2-5	2-2
CHAPTER	3. REPAIR OF ENGINE ACCESSORIES (electrical equipment)		
Section	I. Generator assembly	3-1, 3-2	3-1
	II. Starter assembly	3-3, 3-4	3-2 3-3
	III. Engine	3-5	3-4
CHAPTER	4. REPAIR OF AIR COMPRESSOR		
Section	I. Cylinder head, valves, and intercooler	4-1-4-4	4-1, 4-2
	II. Cylinder and pistons	4-5-4-8	4-2
	III. Centrifugal unloader	4-9 4 12	4-3
	IV. Crankcase and crankshaft	4-13—4-17	4-5, 4-6
CHAPTER	5. REPAIR OF LUBRICATING EQUIPMENT		
Section	I. Air receiver	5-1, 5-2	5-1
	II. Hose reel	5-3-5-6	5-2
	III. Meters	5-6-5-9	5-2
	IV. Control valve	5-10-5-13	5-4, 5-5
	V. Lubricating unit pumps	5-14—5-17	5-5
	VI. Transfer pump	5-18—5-21	5-12
	VII. Skid base	5-22—5-24	5-14
CHAPTER	6. REPAIR OF TRAILER COMPONENTS		
Section	I. Service brakes	6-1-6-6	6-1, 6-2
	II. Axle assembly	6-7, 6-8	6 4
	III. Trailer frame	6-9, 6-10	6-5
APPENDIX	A. References		A-1
ALPHABETICAL INDEX			I-1

This manual supersedes TM 5-4930-207-35, 18 May 1966.

LIST OF ILLUSTRATIONS

Number	Title	Page
1-1	Compressor piston and ring assembly and repair standards -----	1-2
3-1	Generator assembly, disassembly and reassembly -----	3-1
3-2	Starter assembly, disassembly and reassembly -----	3-3
4-1	Cylinder head, valves, and intercooler, disassembly and reassembly -----	4-1
4-2	Cylinder and pistons, removal, disassembly, reassembly, and installation -----	4-3
4-3	Centrifugal unloader, removal, disassembly, reassembly, and installation -----	4-4
4-4	Crankcase and crankshaft, disassembly and reassembly -----	4-5
5-1	Air receiver, removal and installation -----	5-1
5-2	Hose reel, disassembly and reassembly -----	5-2
5-3	Typical hand meter, disassembly and reassembly -----	5-3
5-4	Control valve, disassembly and reassembly -----	5-4
5-5	High and low pressure lubricant pump motor, disassembly and reassembly (Sheet 1 of 4)-----	5-6
5-5	High and low pressure lubricant pump motor, disassembly and reassembly (Sheet 2 of 4) -----	5-7
5-5	High and low pressure lubricant pump motor, disassembly and reassembly (Sheet 3 or 4)-----	5-8
5-5	High and low pressure lubricant pump motor, disassembly and reassembly (Sheet 4 of 4) -----	5-9
5-6	Removing nut from piston rod of lubricant pump-----	5-9
5-7	Low pressure tube, disassembly and reassembly -----	5-10
5-8	High pressure tube, disassembly and reassembly-----	5-11
5-9	Transfer pump, disassembly and reassembly -----	5-13
6-1	Air filter, disassembly and reassembly -----	6-1
6-2	Hydraulic master cylinder, disassembly and reassembly -----	6-2
6-3	Brakeshoe, disassembly and reassembly -----	6-3
6-4	Wheel cylinders, disassembly and reassembly -----	6-3
6-5	Backplane, removal and installation-----	6-4
6-6	Axle assembly, removal and installation -----	6-5

CHAPTER 1

INTRODUCTION

Section I. GENERAL

1-1. Scope

a. This manual is published for the use of direct support and general support maintenance personnel maintaining the Henry Spen Model 901765-1 Lubricating and Servicing Unit. It provides maintenance information beyond the scope of the tools, equipment, personnel, or supplies normally available to using organizations.

which are to be used by maintenance personnel at all levels are listed in and prescribed by TM 38-750.

b. Report of errors, omissions, and recommendations for improving this publication by the individual user is encouraged. Reports should be submitted on DA Form 2028 (Recommended Changes to Publications), and forwarded direct to the Commanding General, U.S. Army Mobility Equipment Command, ATTN: AMSME-MPP, 4300 Goodfellow Boulevard, St. Louis, Mo. 69120.

1-2. Forms and Records

a. Maintenance forms, records, and reports

Section II. DESCRIPTION AND DATA

1-3. Description

TM 5-4930-207-12 provides a general description of the unit; a more detailed description of specific components and assemblies is contained in the applicable sections of the manual.

b. *Tabulated Data.*

(1) Refer to TM 64930-207-12 for complete tabulated data of the lubricating unit,

(2) *Engine data.* Refer to TM 5-280S-203-14 for tabulated data related to the gasoline engine, model 4A032-11.

(3) *Compressor nut and torque data.*

Cylinder Head -----55 ft-lbs.

Cylinder:

Nuts -----12 ft-lbs.

Studs -----55 ft-lbs.

Connecting Rod -----25 ft-lbs.

Valves -----20 ft-lbs.

(4) *Wiring diagram.* Refer to TM 5-4930-207-12 for wiring diagram.

(5) *Repair and replacement standards.* Figure 1-1 and table 1-1 lists the manufacturers sizes, tolerances, desired clearances, and maximum allowable wear and clearances for the compressor assembly.

1-4. Differences Between Models







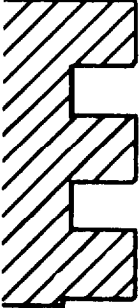

This manual covers only the Henry Spen & Co. Model 901765-1 Lubricating and Servicing Unit. No known unit differences exist for the model covered by the manual.

1-5. Tabulated Data

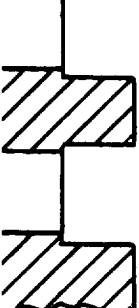

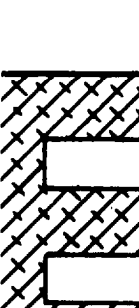





a. *General.* This paragraph contains all overhaul data pertinent to direct support and general support maintenance personnel.

Table 1-1. Compressor Clearance and Fitting Requirement

	Low pressure piston 4-1/8	High pressure piston (2-1/8)
Rod bearing to crank	.001-.002	.001-.002
Piston pin to piston	Light tap fit .0001-.0006 press	Light tap fit .0001-.0005 press
Piston pin to rod bearing	.006-.0010	.006-.0010
Piston side clearance	.006 feeler gauge	.002 feeler gauge
Piston ring end gap	.012-.025	.007-.017
Piston ring side clearance	.002-.004	.002-.004
Crankshaft end play	.007-.020	.007-.020

PISTON CROSS SECTION	GROOVE WIDTH	DIAMETER BOTTOM OF RING GROOVE	RING CROSS SECTION	RING WIDTH	RING THICKNESS	LOAD AT DIAMETER	DIAMETER CLEARANCE
	<u>.0955</u>	<u>1.886</u>		<u>.0925</u>	<u>.090</u>	9.5 lb min	<u>.007</u>
	<u>.0965</u>	<u>1.896</u>		<u>.0935</u>	<u>.100</u>		<u>.017</u>
	<u>.0955</u>	<u>1.886</u>		<u>.0925</u>	<u>.090</u>	9.5 lb min	<u>.007</u>
	<u>.0965</u>	<u>1.896</u>		<u>.0935</u>	<u>.100</u>		<u>.017</u>
	<u>.1885</u>	<u>1.846</u>		<u>.1860</u>	<u>.075</u>	Tangential Load of Assembly 6 to 10 lb	<u>.007</u>
	<u>.1895</u>	<u>1.856</u>		<u>.1870</u>	<u>.085</u>		<u>.017</u>
	<u>.1885</u>	<u>1.846</u>		<u>.1860</u>	<u>.090</u>	3.4 lb min	<u>.007</u>
	<u>.1895</u>	<u>1.856</u>		<u>.1870</u>	<u>.100</u>		<u>.017</u>

HIGH PRESSURE PISTON

	<u>.097</u>	<u>3.715</u>		<u>.0925</u>	<u>.166</u>	9.5 lb min	<u>.013</u>
	<u>.098</u>	<u>3.705</u>		<u>.0935</u>	<u>.176</u>		<u>.025</u>
	<u>.097</u>	<u>3.715</u>		<u>.0925</u>	<u>.166</u>	9.5 lb min	<u>.013</u>
	<u>.098</u>	<u>3.705</u>		<u>.0935</u>	<u>.176</u>		<u>.025</u>
	<u>.1895</u>	<u>3.695</u>		<u>.1860</u>	<u>.166</u>	11 lb min	<u>.013</u>
	<u>.1905</u>	<u>3.685</u>		<u>.1870</u>	<u>.176</u>		<u>.025</u>
	<u>.1895</u>	<u>3.695</u>		<u>.1860</u>	<u>.166</u>	11 lb min	<u>.013</u>
	<u>.1905</u>	<u>3.685</u>		<u>.1870</u>	<u>.176</u>		<u>.025</u>

LOW PRESSURE PISTON

ME 4930-207-34/1-1

Figure 1-1. Compressor piston and ring assembly and repair standards.

CHAPTER 2

DIRECT SUPPORT AND GENERAL SUPPORT MAINTENANCE INSTRUCTION

Section I. REPAIR PARTS, SPECIAL TOOLS AND EQUIPMENT

2-1. Tools and Equipment

No tools and equipment are issued with or authorized for the lubricating and servicing unit.

forming maintenance on the lubricating and servicing unit.

2-2. Special Tools and Equipment

No special tools and equipment are required for direct support and general support personnel per-

2-3. Maintenance Repair Parts

Direct support and general support maintenance repair parts are listed and illustrated in TM 5-4930-207-35P.

Section II. TROUBLESHOOTING

2-4. General

This section provides information useful in diagnosing and correcting unsatisfactory operation or failure of the lubricating and servicing unit or any of its components. Malfunctions which may

occur are listed in table 2-1. Each malfunction stated is followed by a list of probable causes of the trouble. The corrective action recommended is described opposite the probable cause. Refer to TM 5-2805-203-14 for troubleshooting the engine assembly.

Table 2-1. Troubleshooting

Malfunction	Probable cause	Corrective action
1. Compressor high or low pressure system overheats.	a. Scored piston or cylinder wall.	a. Replace piston or hone cylinder wall (para 4-5 thru 4-8).
2. Compressor knock or develops excessive noise	b. Broken discharge valves or springs.	b. Replace valves (para 4-2).
	a. Piston pins worn.	a. Replace piston pins and pistons (para 4-5 thru 4-8).
3. Excessive compressor oil consumption.	b. Connecting rods loose.	b. Replace defective bearings (para 4-6 thru 4-8).
	a. Incorrect oil.	a. Change oil and add correct oil (Refer to LO 5-4930-207-12).
4. Transfer pump does not operate.	b. Clogged air cleaner.	b. Replace air cleaner (TM 5-4930-207-12).
	c. Worn piston rings.	c. Replace piston rings. Be sure rings are installed correctly (para 4-6 thru 4-8).
5. Lubricant supply pump does not operate.	a. Defective air valve and piston.	a. Repair or replace air valve or piston (para 5-19 thru 5-21).
	b. Defective foot valve.	b. Repair or replace foot valves (para 5-19 thru 5-21).
6. Brakes fail.	a. Defective control or metering valves.	a. Replace valves (para 5-7 thru 5-9).
	b. Defective pumps.	b. Repair or replace pumps (para 5-15 thru 5-17).
7. Brakes noisy	a. Brake linings worn or excessively dirty or greasy.	a. Replace linings (para 6-4).
	b. Master cylinder defective	b. Replace or repair master cylinder (para 6-3).
8. Brakes grab	Brake linings worn, dirty or greasy	Replace linings (para 6-4).
	Brake linings oily or greasy	Replace linings (para 6-4).

Section III. REMOVAL AND INSTALLATION OF MAJOR COMPONENTS AND AUXILIARIES

2-5. General

This section contains the removal and installation instructions for the lubricating unit. For removal and installation instructions on the engine assembly, compressor assembly, three lubricating pumps, reel bank assembly, alcohol injector assembly, and control panel assembly refer to TM 5-4930-207-12.

2-6. Lubricating Unit

a. Removal. The entire lubricating unit can be removed from the trailer assembly by removing six screws, nuts, and washers which attach it to the trailer bed. Carefully lift the unit with an overhead crane or fork lift truck that has a minimum of 6,000 lbs. capacity.

b. Installation. Installation is the reverse of removal.

CHAPTER 3

REPAIR OF ENGINE ACCESSORIES (ELECTRICAL EQUIPMENT)

Section I. GENERAL ASSEMBLY

3-1. General

The generator assembly has an armature mounted at both ends on bearings. The armature rotates between pole shoes over which are wound field coils. The voltage and current developed in the armature windings is supplied through brushes riding on a commutator to the generator terminals and then to the batteries and other electrical accessories in the circuit.

3-2. Generator

a. Removal and Disassembly.

(1) Remove generator assembly and voltage regulator as described in TM 5-4930-207-12.

(2) Disassemble the generator assembly in numerical sequence as shown in figure 3-1.

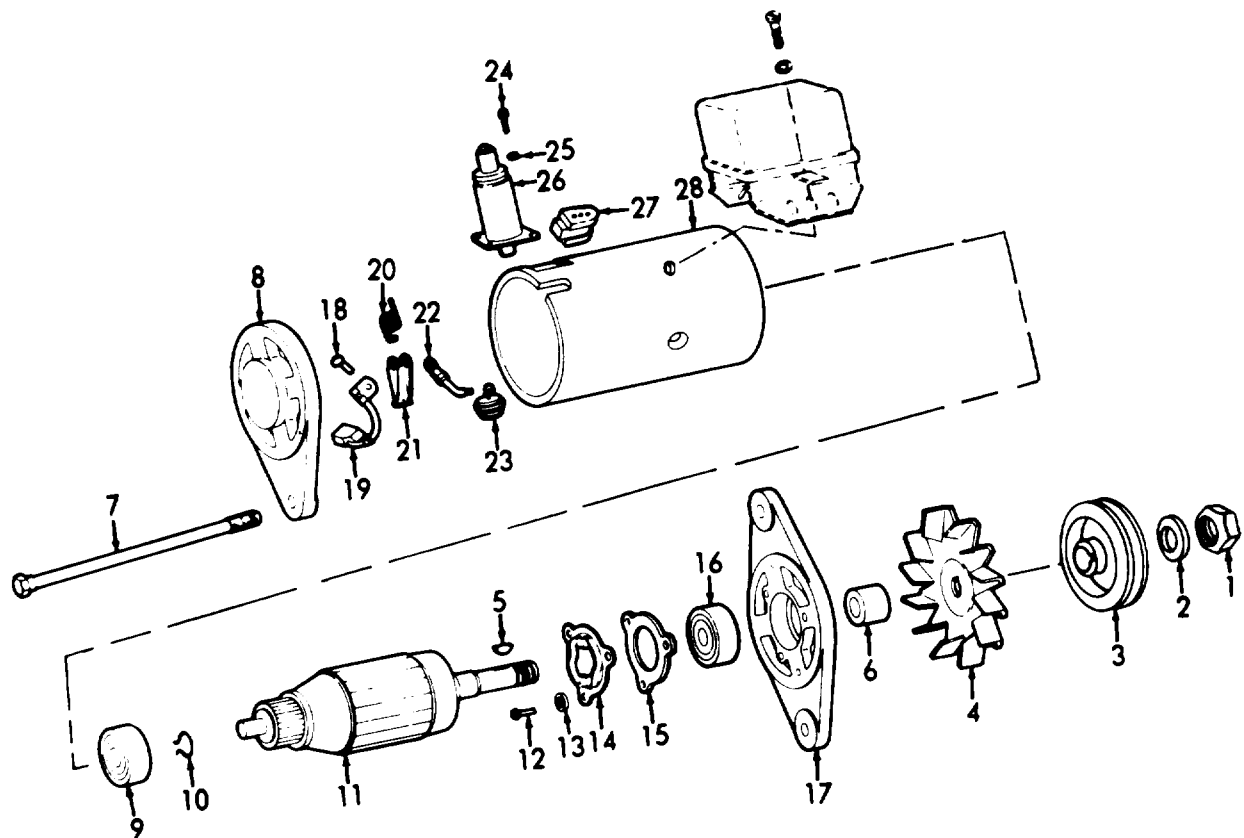

ME 4930-207-34/3-1

- | | | | |
|-----------|------------------|-------------------|-----------------|
| 1. Nut | 8. Head assembly | 15. Retainer | 22. Lead |
| 2. Washer | 9. Ball bearing | 16. Bearing | 23. Rectifier |
| 3. Pulley | 10. Clip | 17. Head Assembly | 24. Screw (4) |
| 4. Fan | 11. Armature | 18. Screw | 25. Washer (4) |
| 5. Key | 12. Screw | 19. Brush | 26. Capacitor |
| 6. Spacer | 13. Washer | 20. Spring (2) | 27. Grommet |
| 7. Bolt | 14. Plate | 21. Brush set (2) | 28. Frame-field |

Figure 3-1. Generator assembly, disassembly and reassembly.

b. Cleaning.

(1) Use a cloth dampened with P-D-680 to wipe all dust, oil, and foreign material from the brush plates, end frames, armature, and field assemblies.

(2) Use filtered compressed air to blow dust and dirt from crevices of the armature and field windings.

(3) Secure armature in a lathe. With armature spinning, hold an emery cloth against the commutator until the copper is bright and smooth.

c. Inspection.

(1) Examine field coils for worn or burned insulation. Be certain connections between field coils are secure. Repair connections if necessary.

(2) Examine field frame assembly for cracks or distortions. Check thread conditions in tapped holes.

(3) Check drive end head for cracks or warping. Inspect shaft end of armature for damage and wear.

(4) Examine pulley for broken flanges and worn shaft hole. Inspect brushes for wear or damage.

d. Repair.

(1) Check commutator with a dial indicator for out-of-round. If total out-of-round exceeds 0.001 inch, turn down commutator on lathe.

(2) Replace armature or coils if tests indicate shorts.

(3) Replace all parts indicating cracks, wear, or damage.

(4) Replace brush springs that are worn or fatigued. Replace brushes.

(5) Undercut mica insulation between the commutator bars to a depth of 1/32 of an inch. When undercutting mica, the cut should be square and free of burrs.

e. Testing.

(1) Use a conventional test light and check field coils for open circuits and shorts to ground or between coils.

(2) Check armature assembly for open coils and shorts to ground, or between coils by using a test light.

(3) Check brush holders for shorts to ground with a test light.

f. Armature End Play Test.

(1) Align end of armature shaft with plunger of dial indicator. Pull shaft to outer limit and set dial indicator.

(2) Push shaft in toward commutator end of generator to its inner limit. Dial indicator should read between 0.003 and 0.010 inch.

(3) If dial indicator reading is not within these limits, improper assembly or worn parts are possible causes. Check bearings to be sure of proper seating.

g. Reassembly and Installation.

(1) Reassembly is the reverse of disassembly. Refer to figure 3-1.

(2) Install the generator assembly and voltage regulator as instructed in TM 5-4930-207-12.

h. Field Current Draw Test.

(1) Connect the generator in series with a battery, battery switch, variable resistor, and ammeter. Connect a voltmeter between the armature and field connections.

(2) Before closing battery switch, connect ammeter to its highest range. Close battery switch and read ammeter. Open battery switch and connect ammeter to lowest range which will safely carry current indicated in first reading.

(3) Close battery switch. Adjust variable resistance to produce a reading of 5 volts on the voltmeter. The ammeter should indicate 1.00 to 1.05 amperes.

i. Polarizing Generator.

(1) Polarize generator before starting engine whenever generator cable has been removed from generator.

(2) Disconnect generator-to-voltage regulator cable, and battery connection cable from voltage regulator; momentarily connect a wire from the "B" terminal of generator cable to battery connection cable.

(3) Install cable.

Section II. STARTER ASSEMBLY

3-3. General

The shift lever cranking motor has the shift lever mechanism and the solenoid plunger enclosed in the drive housing protecting them from exposure to dirt and icing conditions. A solenoid switch

mounted to the flange on the starting motor drive housing operates the overrunning clutch drive by means of a linkage and shift lever. When the control switch closes the cranking circuit the solenoid is energized, shifting the starting motor pinion into mesh with the engine flywheel ring gear and

closing the main contacts located inside the solenoid. Battery current is then directed to the motor causing the armature to rotate. Cranking torque is transmitted by the clutch from the starting motor armature to the engine flywheel ring gear.

3-4. Starter

a. Removal and Disassembly.

(1) Remove starter assembly as instructed in TM 5-4930-207-12. Match mark the frame (16, fig. 3-2), starter motor housing (30), shift lever housing (14), and drive housing (7) to assure proper reassembly.

(2) Disassemble the starter assembly in numerical sequence as shown, in figure 3-2.

(3) Do not remove pole shoes (27), field coils (29), or coil assembly unless replacement parts are needed.

b. Cleaning.

(1) Use a cloth dampened with P-D-680 to wipe all dust, oil, and other foreign material from the brush plates, end frames, armature and field assemblies.

(2) Use filtered compressed air to blow dust and dirt from the crevices of the armature and field windings.

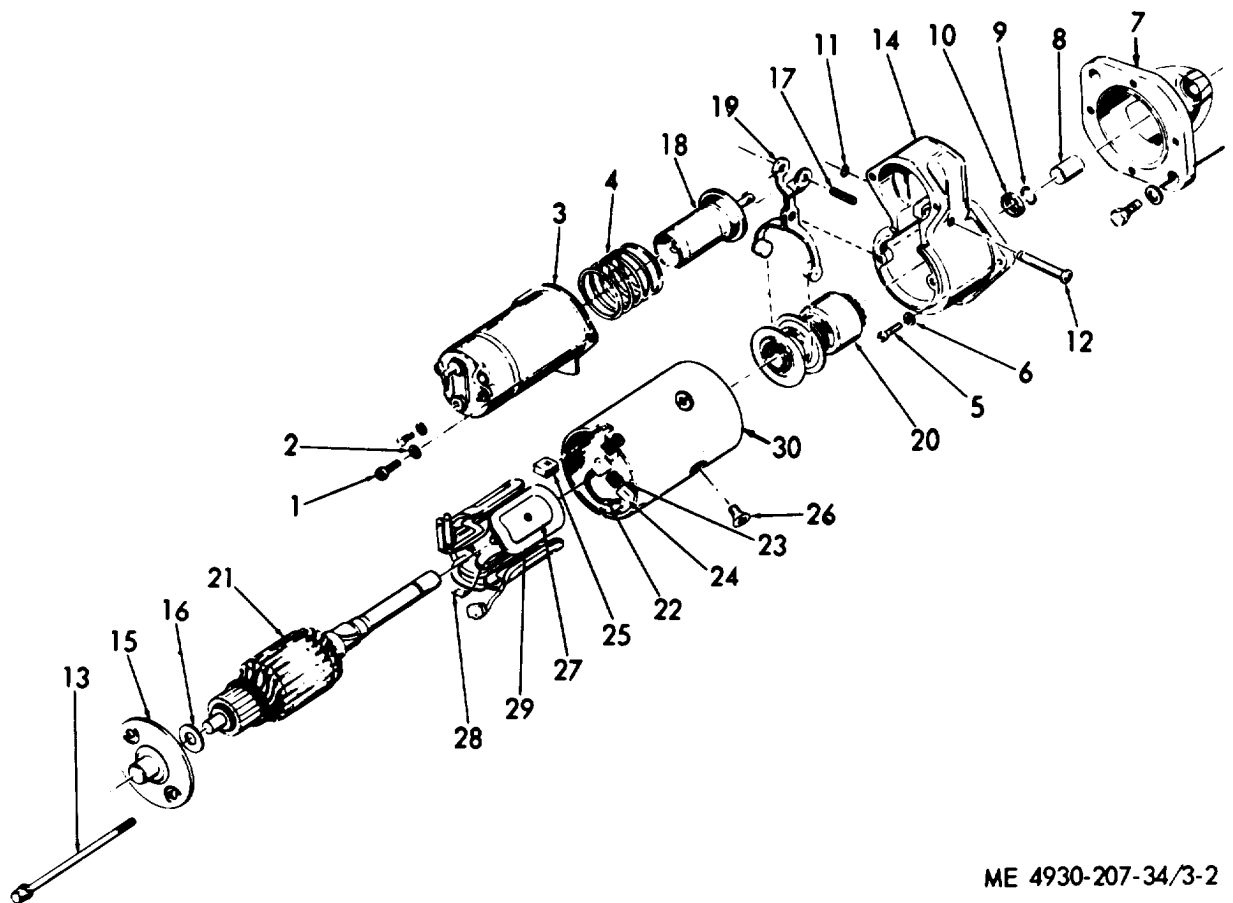

ME 4930-207-34/3-2

- | | | |
|--------------------|-------------------------|---------------------------|
| 1. Screw (2) | 11. Snapping | 21. Armature |
| 2. Washer (2) | 12. Stud | 22. Starter brush pkg (2) |
| 3. Solenoid switch | 13. Bolt (2) | 23. Spring |
| 4. Spring | 14. Shift lever housing | 24. Brush holder |
| 5. Screw (4) | 15. Frame | 25. Grommet |
| 6. Washer (4) | 16. Washer | 26. Screw (4) |
| 7. Drive housing | 17. Pin | 27. Pole shoe (4) |
| 8. Bushing | 18. Plunger assembly | 28. Coil assy |
| 9. Ring | 19. Lever assembly | 29. Field coil |
| 10. Pinion stop | 20. Clutch | 30. Housing |

Figure 3-2. Starter assembly, disassembly and reassembly.

(3) Secure armature in a lathe. With armature spinning, hold an emery cloth against the commutator until the copper is bright and smooth.

c. Inspection

(1) Examine field frame assembly for cracks or warping, inspect armature shaft end for damage or wear.

(2) Examine clutch for broken or cracked teeth.

(3) Examine field coils for worn, burned, and frayed insulation. Be certain connections between field coils are secure. Repair connections if necessary.

(4) Inspect springs for distortion or fatigue. Examine brushes for damage or excessive wear.

d. Repair.

(1) Replace armature or coils if tests indicate shorts.

(2) If commutator is out-of-round in excess of 0.001 inch, turn down on lathe.

(3) Replace damaged or worn solenoid switch.

(4) Replace all parts indicating wear, cracks, or damage.

(5) Undercut mica insulation between the commutator bars to a depth of 1/32 of an inch. When undercutting mica, the cut should be square and free of burrs.

e. Testing.

(1) Check brush holder for shorts to ground using a test light.

(2) Test armature assembly for open coils and shorts to ground, or between coils by using a test light.

(3) Check field coils for open circuits and shorts to ground, or between coils using a test light.

f. Reassembly and installation.

(1) Reassembly is the reverse of disassembly. Refer to figure 8-2.

(2) Install the starter assembly as instructed in TM 5-4930-207-12.

g. No-Load Test.

(1) Connect the starting motor in series with a fully charged battery, an ammeter capable of reading several hundred amperes, and a variable resistor. Also connect a voltmeter from the motor frames. An rpm indicator is necessary to measure armature speed.

(2) Obtain the specified voltage of 23 volts by varying the resistance unit. The current draw must be 90 amperes maximum and the current speed at these readings must be a maximum of 10,700 rpm.

**3-5. Engine, Gasoline, Model
4A032-11**

a. General. The engine is a four-cylinder, air cooled, overhead valve, gasoline type which operates the compressor on the lubricating unit.

b. Removal and Installation. Refer to TM 5-4930-207-12 for removal and installation instructions.

c. Repair. Refer to TM 5-2805-208-14 for engine repair instructions.

CHAPTER 4

REPAIR OF AIR COMPRESSOR

Section I. CYLINDER HEAD, VALVES, AND INTERCOOLER

4-1. General

The cylinder head has a disk type valve system. The intercooler cools the air coming from the low pressure cylinder before it enters the high pressure cylinder.

4-2. Cylinder Head, Valves, and Intercooler Removal and Disassembly

a. *Removal.* Refer to TM 5-4930-207-12 to remove the lines and fittings and air cleaner.

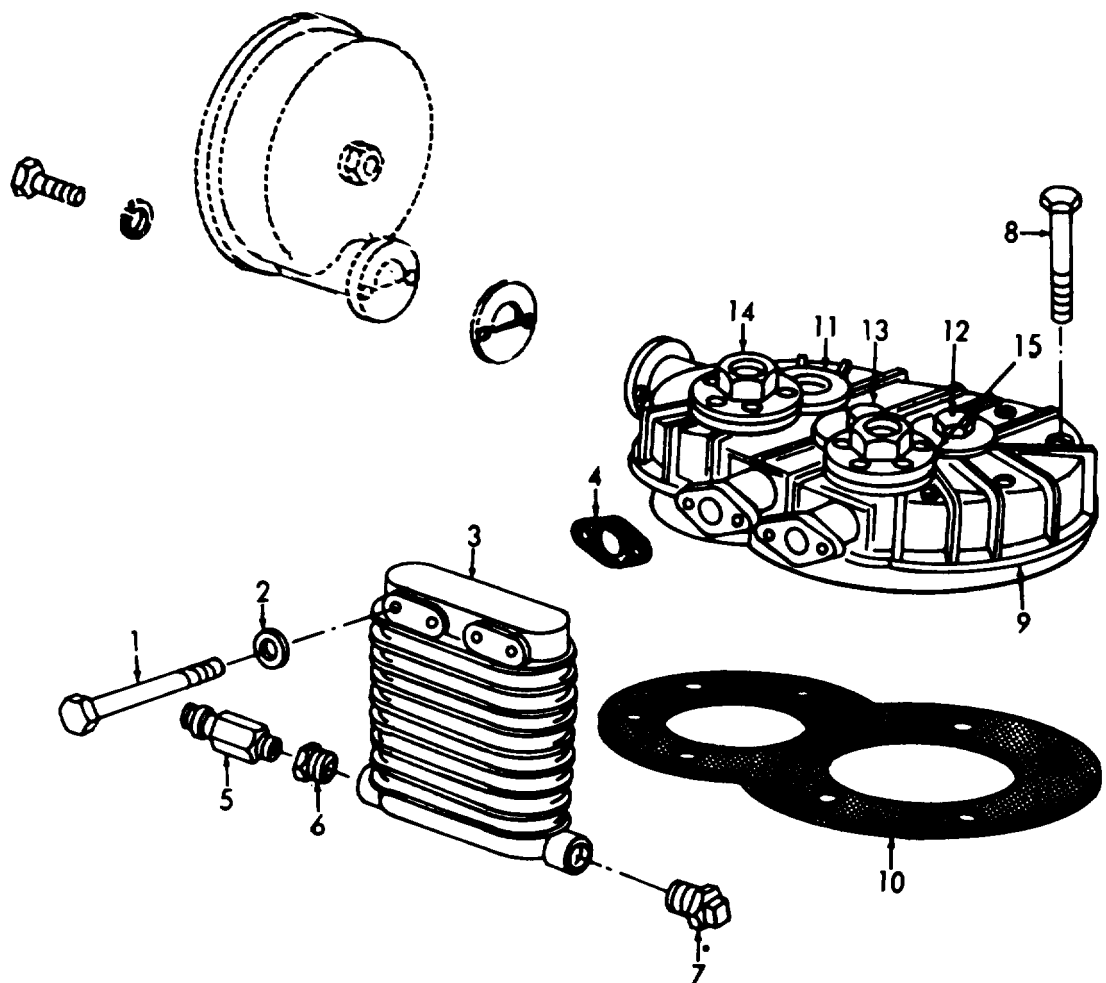

ME 4930-207-34/4-1

- 1. Bolt (4)
- 2. Washer (4)
- 3. Intercooler
- 4. Gasket
- 5. Valve

- 6. Bushing
- 7. Plug
- 8. Screw (8)
- 9. Head
- 10. Gasket

- 11. Valve
- 12. Valve
- 13. Valve
- 14. Valve
- 15. Valve

Figure 4-1. Cylinder head, valves, and intercooler, disassembly and reassembly.

Remove eight screws (8) and lift off cylinder head (9) and intercooler (3).

b. Disassembly. Disassemble the cylinder head, valves, and intercooler as illustrated in figure 4-1.

4-3. Cylinder Head Valves and Intercooler Inspection and Repair

a. Inspection. Inspect valves, valve seats, valves springs and stops for nicks, scoring, burning, warping, and noticeable wear. Discard worn or damaged parts. Check cylinder head and inter-

cooler for cracked or chipped castings, and damaged screw threads.

b. Repair. Repair by replacing damaged parts.

4-4. Cylinder Head, Valves and Intercooler Reassembly and Installation

a. Reassembly. The cylinder head, valves, and intercooler are reassembled in reverse of disassembly, refer to figure 4-1, replace gaskets.

b. Installation. Install cylinder head (9) and intercooler (3). Refer to TM 5-4930-207-12 and install the air cleaner, lines and fittings.

Section II. CYLINDER AND PISTONS

4-5. General

The twin-cylinder construction gives a higher discharge pressure with less consumption of power. The larger cylinder is a low pressure cylinder and the smaller is the high pressure cylinder. The low pressure, or first stage, exhausts air into an intercooler which cools the air before it enters under pressure (45 psi) into the high pressure cylinder.

4-6. Cylinder and Pistons Removal and Disassembly

a. Removal.

(1) Refer to TM 5-4930-207-12 for removal of lines and fittings and the compressor assembly,

(2) Remove side cover (13, fig. 4-4) from crankcase (17). Remove bolts (8, fig. 4-1) and lift off cylinder head (9) and gasket (10).

b. Disassembly. Refer to figure 4-2 and remove and disassemble the cylinder and pistons as illustrated in numerical sequence,

4-7. Cylinder and Pistons Cleaning and Inspection

a. Cleaning.

(1) Wash parts with P-D-680. Dry parts except bearings with a clean lint-free cloth.

(2) Bearings are dried by the vacuum air method. Lubricate bearings immediately after cleaning.

NOTE

Avoid touching clean bearings with bare fingers; do not spin bearing while dry.

b. Inspection. Check cylinders bores, pistons, connecting rods, and pins for excessive wear, scoring, and other damage.

4-8. Cylinder and Pistons Reassembly and Installation

a. Reassembly. Replace gasket (10), refer to figure 4-2 and reassemble and install in reverse order.

NOTE

Be sure rings are installed correctly. Compression rings (15, 16, 24, and 25) are taper faced and on one side the word "TOP" is etched on the ring. Be sure this marking is facing up. Oil rings (18, 19, 26, and 27) are of the slotted type and also must be installed correctly, see figure 1-2 and table 1-1.

b. Installation.

(1) Install side cover (13, fig. 4-4). Install cylinder head (9, fig. 4-1) and bolts (8), replace gasket (10).

(2) Refer to TM 5-4930-207-12 and install the lines and fittings.

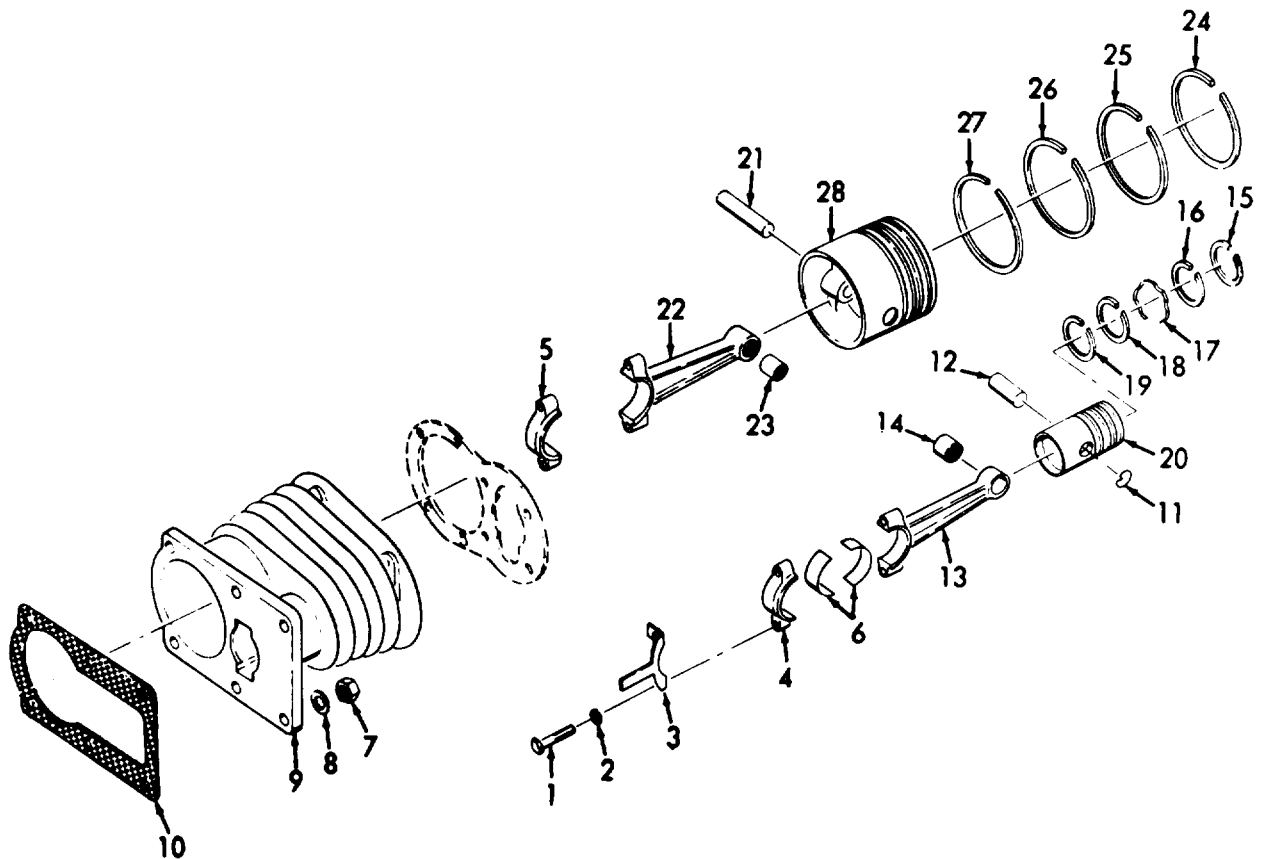

ME 4930-207-34/4-2

- | | | |
|---------------|--------------|-------------|
| 1. Screw (2) | 11. Retainer | 20. Piston |
| 2. Washer (2) | 12. Pin | 21. Pin |
| 3. Plate | 13. Rod | 22. Rod |
| 4. Rod cap | 14. Bearing | 23. Bearing |
| 5. Rod cap | 15. Ring | 24. Ring |
| 6. Shell | 16. Ring | 25. Ring |
| 7. Nut (6) | 17. Ring | 26. Ring |
| 8. Washer (6) | 18. Ring | 27. Ring |
| 9. Cylinder | 19. Ring | 28. Piston |
| 10. Gasket | | |

Figure 4-2. Cylinder and pistone, removal, disassembly, reassembly, and installation.

Section III. CENTRIFUGAL UNLOADER

4-9. General

The centrifugal unloader automatically opens a valve releasing compression from the compressor cylinders and intercooler each time the compressor stops.

4-10. Centrifugal Unloader Removal and Disassembly

For removal and disassembly of the centrifugal unloader see figure 4-3, illustrated in numerical sequence breakdown.

4-11. Centrifugal Unloader Inspection and Repair

a. Inspection

(1) Inspect tube assembly and fittings for worn or damaged screw threads, cracks, dents, sharp bends, and other defects.

(2) Inspect housing and cover for cracks and other damage.

b. Repair. Repair by replacing damaged parts.

4-12. Centrifugal Unloader Reassembly and Installation

Refer to figure 4-3 for reassembly and installation. Replace gaskets.

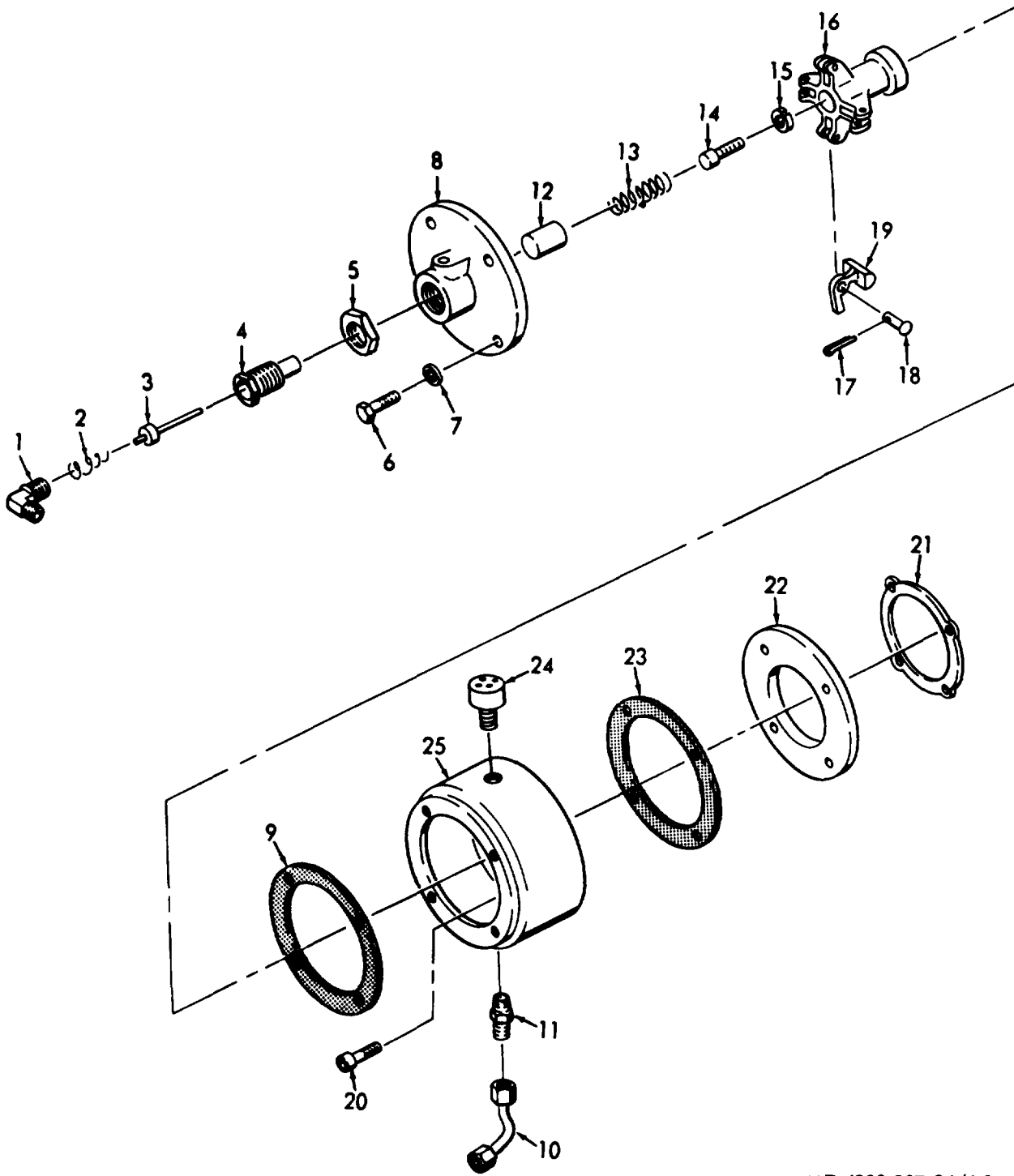

ME 4930-207-34/4-3

- 1. Elbow
- 2. Spring
- 3. Plunger
- 4. Body
- 5. Nut
- 6. Bolt (4)
- 7. Washer (4)
- 8. Cover
- 9. Gasket

- 10. Tube
- 11. Connector
- 12. Plunger
- 13. Spring
- 14. Screw
- 15. Washer
- 16. Body
- 17. Key (4)

- 18. Pin (4)
- 19. Weight
- 20. Screw (4)
- 21. Shim
- 22. Spacer
- 23. Gasket
- 24. Breather
- 25. Housing

Figure 4-3. Centrifugal unloader, removal, disassembly, reassembly, and installation.

Section IV. CRANKCASE AND CRANKSHAFT

4-13. General

The crankcase is equipped with a sight glass which provides maximum protection against damage due to insufficient oil; however the splash-type lubrication system provides adequate lubrication, even if the oil level in the reservoir is low.

4-14. Crankcase and Crankshaft Removal and Disassembly

a. Removal

(1) Refer to TM 5-4930-207-12 and remove the compressor assembly.

(2) Remove flywheel as instructed in TM 5-4930-207-12.

(3) Remove cylinder and pistons as instructed in section II. (para 4-6a (1) and (2)).

(4) Remove centrifugal unloader per section III. (para 4-10).

b. Disassembly. Disassemble crankcase and crankshaft in numerical sequence as illustrated in figure 4-4.

4-15. Crankcase and Crankshaft Cleaning

a. Crankcase. Swab out the lubricating oil passages in the crankcase with P-D-680 solvent.

b. Bearings. Clean with P-D-680 and dry with the vacuum air method. Lubricate bearings immediately after cleaning.

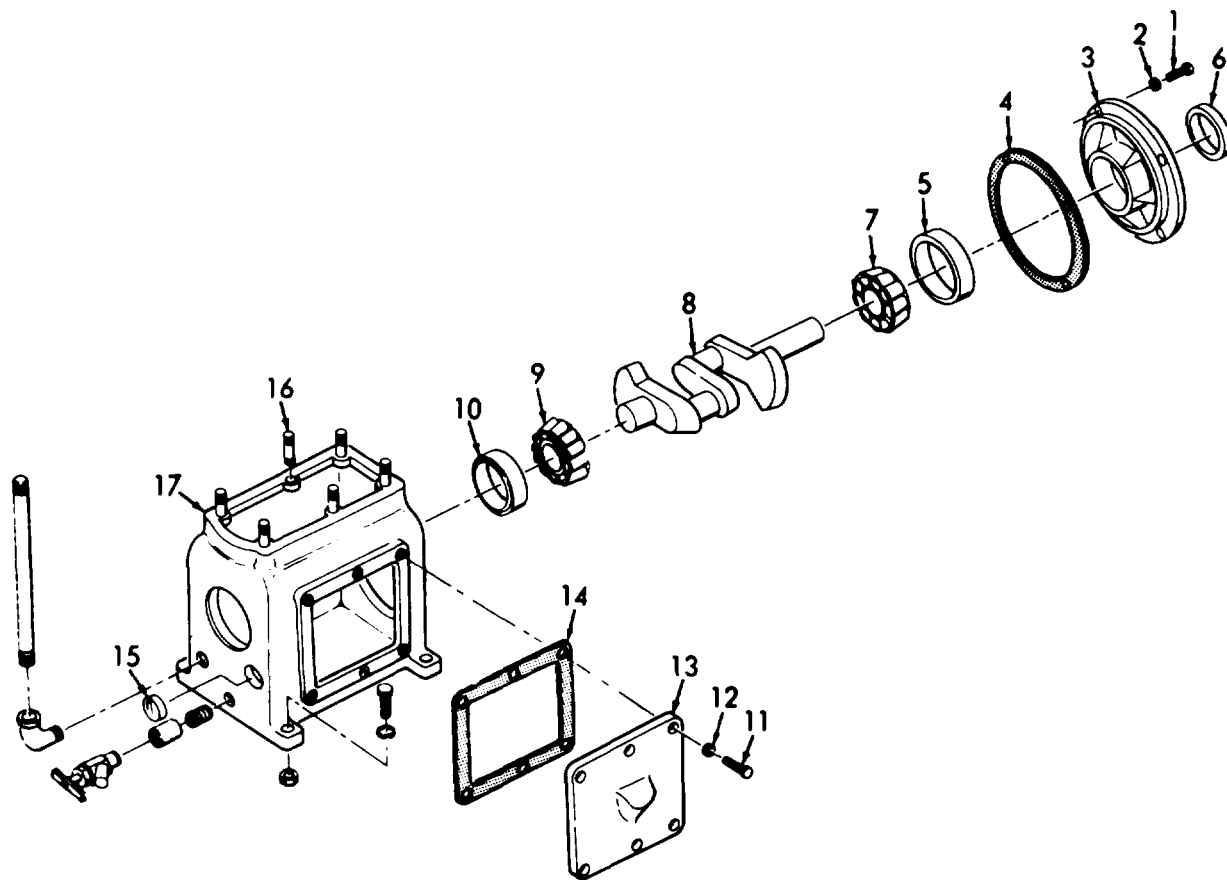

ME 4930-207-34/4-4

- | | | |
|---------------|---------------------|-----------------|
| 1. Bolt (4) | 7. Cone and rollers | 13. Cover |
| 2. Washer (4) | 8. Crankshaft | 14. Gasket |
| 3. Cover | 9. Cone and rollers | 15. Sight glass |
| 4. Gasket | 10. Cup | 16. Stud (6) |
| 5. Cup | 11. Bolt (6) | 17. Crankcase |
| 6. Seal | 12. Washer (6) | |

Figure 4-4. Crankcase and crankshaft, disassembly and reassembly.

NOTE

Avoid touching clean bearings with bare fingers; do not spin bearing while dry.

**4-16. Crankcase and Crankshaft
Inspection and Repair**

a. Inspection.

(1) Inspect crankcase for cracked and chipped castings and damaged stud threads.

(2) Inspect cups, seal, and bearing for excessive wear and damage.

b. Repair. Repair by discarding all damaged and excessively worn or damaged parts.

**4-17. Crankcase and Crankshaft
Reassembly and Installation**

a. Reassembly. Replace gaskets, refer to figure 4-4 and reassemble crankcase and crankshaft in reverse order.

b. Installation.

(1) Install centrifugal unloader as instructed in section III (para 4-12).

(2) Install cylinder and pistons as instructed in section II (para 4-8b (1) and (2)).

(3) Install flywheel as instructed in TM 6-4930-207-12.

(4) Refer to TM 5-4930-207-12 and install the compressor assembly.

CHAPTER 5
REPAIR OF LUBRICATING EQUIPMENT

Section I. AIR RECEIVER

5-1. General

The air receiver is mounted on the skid weldment. It has a 450 psi maximum load. It provides compressed air which forces lubricant and oil from storage tanks through reel-mounted hoses.

5-2. Air Receiver Removal and Installation

a. Removal

(1) Remove lines and fitting and air compressor assembly as instructed in TM 5-4930-207-12.

(2) Refer to TM 5-4930-207-12 and remove belt guard, generator assembly, generator mounting bracket, and engine.

(3) Refer to TM 5-4930-207-12 and remove drain cock, hose, valve, gage, and lines and fittings of the air receiver.

(4) Remove air receiver as shown in numerical sequence in figure 5-1.

b. Installation.

(1) Install air receiver in reverse order as illustrated in figure 5-1.

(2) Install air receiver drain cock, hose, valve, gage, and lines and fittings as instructed in TM 5-4930-207-12.

(3) Refer to TM 5-4930-207-12 and install engine, generator mounting bracket, generator assembly, and belt guard.

(4) Refer to TM 5-4930-207-12 and install air compressor assembly and lines and fittings.

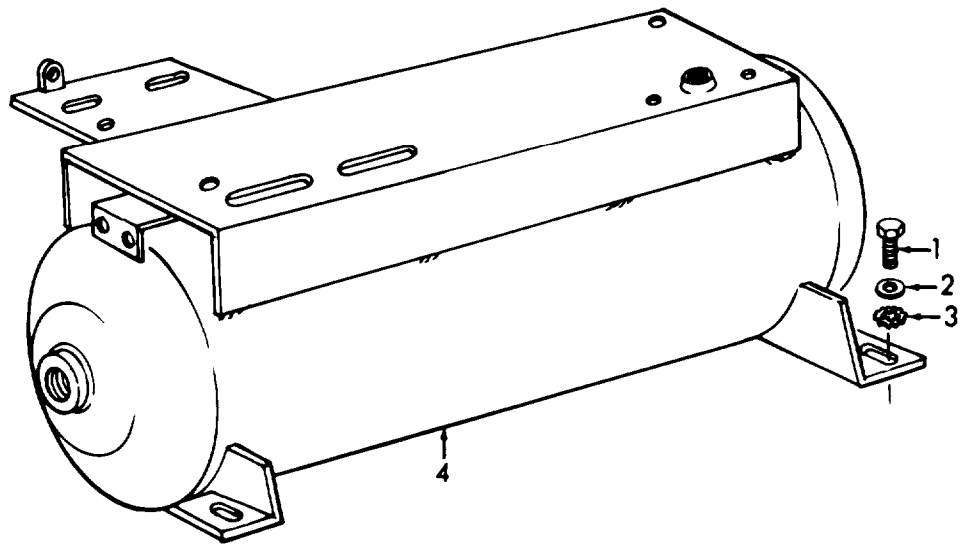

ME 4930-207-34/5-1

1. Bolt (4)
2. Washer (4)

3. Washer (4)

4. Reservoir

Figure 5-1. Air receiver, removal and installation.

Section II. HOSE REEL

5-3. Hose Reel Removal and Disassembly

a. *Removal.* Remove the hose reel as instructed in TM 5-4930-207-12.

b. *Disassembly.* Disassemble the hose reel as illustrated in numerical sequence in figure 5-2.

5-4. Hose Reel Inspection and Repair

a. *Inspection.*

(1) Inspect pedestals and hose reel for bends, cracks, or other defects.

(2) Inspect union and nipple for stripped threads.

(3) Inspect brake assembly, handle, and pin for excessive wear or other damage.

b. *Repair.* Repair all parts by replacement.

5-5. Hose Reel Reassembly and Installation

a. *Reassembly.* Refer to figure 5-2 and reassemble in reverse order.

b. *Installation.* Install the hose reel as shown in TM 5-4930-207-12.

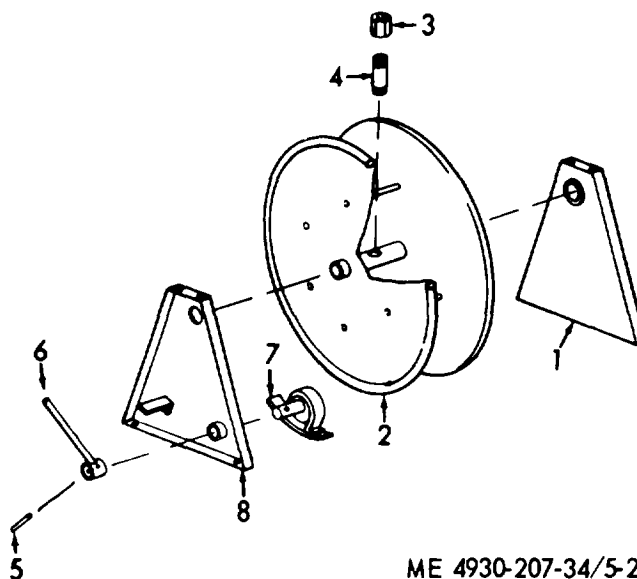

- | | |
|--------------|-------------------|
| 1. Pedestal | 5. Pin |
| 2. Hose reel | 6. Handle |
| 3. Union | 7. Brake assembly |
| 4. Nipple | 8. Pedestal |

Figure 5-2. Hose reel, disassembly and reassembly.

Section III. METERS

5-6. General

The meters are designed for dispensing gear and motor oil. The gear hand meter indicates amount dispensed in pints and the motor hand meter in quarts.

5-7. Meters Removal and Disassembly

a. *Removal.* Remove meters as instructed in TM 5-4930-207-12.

b. *Disassembly.* A typical disassembly of both meters is illustrated in numerical sequence in figure 5-3.

5-8. Meters Cleaning, Inspection, and Repair

a. *Cleaning.* Clean all parts with P-D-680 and dry with clean lint-free cloth.

b. *Inspection and Repair.*

(1) Inspect all parts for wear or leakage. Replace defective parts.

(2) If lubricant leaks around the fitting body (7) replace O-rings (8, 9).

(3) If lubricant leaks around the face dial (2) replace flat packing (15) and leather washer (14).

(4) If lubricant leaks around the lubricant inlet replace V-block packing (21) and gasket (18).

(5) If lubricant leaks around the lever assembly (25) replace O-rings (29, 30).

5-9. Meters Reassembly and Installation

a. *Reassembly.* Reassemble both meters in reverse of removal, see figure 5-3.

b. *Installation.* Install meters as instructed in TM 5-4930-207-12.

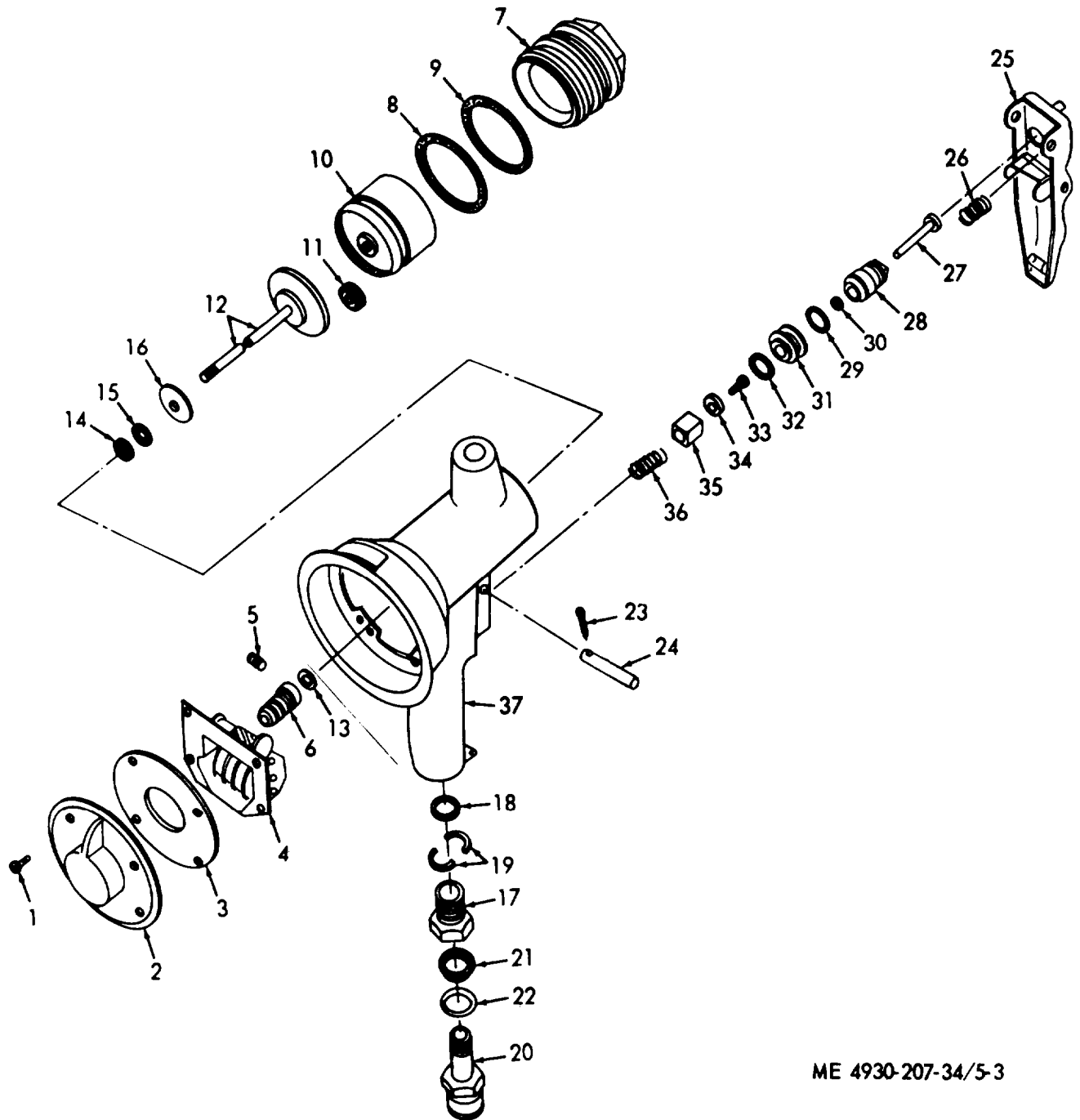

ME 4930-207-34/5-3

- | | | |
|---------------------------------|--------------------|--------------------------|
| 1. Screw (4) | 14. Leather washer | 26. Spring |
| 2. Face dial | 15. Packing | 27. Cap and pin assembly |
| 3. Spacer | 16. Washer | 28. Plug |
| 4. Totalizer | 17. Swivel adapter | 29. O-ring |
| 5. Adjusting screw | 18. Gasket | 30. O-ring |
| 6. Worm gear | 19. Split ring (2) | 31. Valve seat |
| 7. Fitting body | 20. Swivel stem | 32. O-ring |
| 8. O-ring | 21. Packing | 33. Screw |
| 9. O-ring | 22. Washer | 34. Seat |
| 10. Metering mechanism assembly | 23. Pin | 35. Plunger |
| 11. Planetary gear | 24. Pin | 36. Spring |
| 12. Gear and shaft assembly | 25. Lever assembly | 37. Housing |
| 13. Washer | | |

Figure 5-3. Typical hand meter, disassembly and reassembly.

Section IV. CONTROL VALVE

5-10. General

The two control valves are of the squeeze lever type and are used to control the amount of grease being dispensed.

5-11. Control Valves Removal and Disassembly

a. Removal. Unscrew the two grease control valves from the two grease lubricant reels, see TM 5-4930-207-12.

b. Disassembly. Refer to figure 5-4 and disassemble the control valves as shown in numerical sequence.

5-12. Control Valves Inspection and Repair

a. Inspection.

- (1) Inspect part for wear, damage or defects.
- (2) Compress spring plunger and seat assembly (24) and check for scored seat.

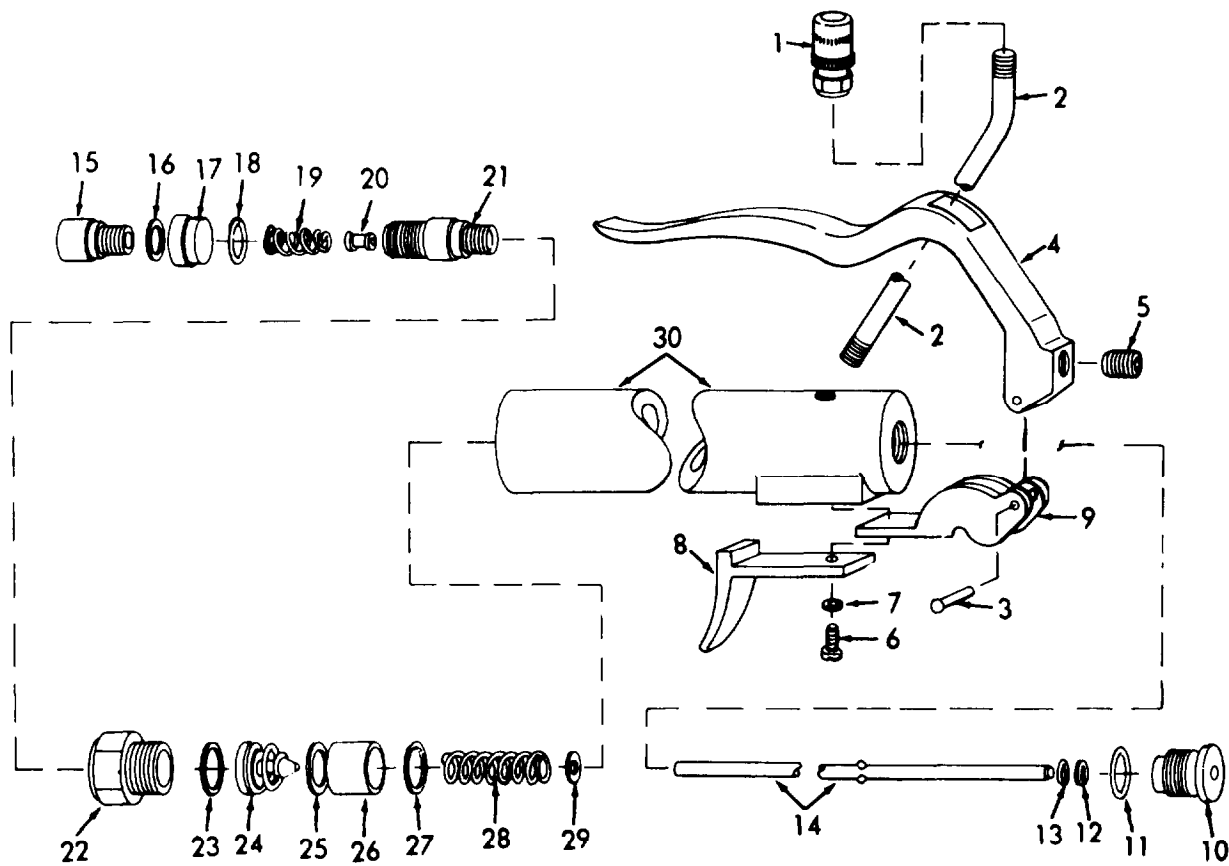

ME 4930-207-34/5-4

- | | | |
|----------------------|------------------|----------------------------------|
| 1. Hydraulic coupler | 11. Packing | 21. Valve bushing |
| 2. Extension | 12. Washer | 22. Bushing |
| 3. Rivet | 13. Packing | 23. Gasket |
| 4. Lever | 14. Plunger stem | 24. Spring-plunger-seat assembly |
| 5. Setscrew | 15. Connector | 25. Gasket |
| 6. Screw | 16. Gasket | 26. Spacer |
| 7. Washer | 17. Nut | 27. Gasket |
| 8. Support | 18. Packing | 28. Spring |
| 9. Bracket | 19. Spring | 29. Washer |
| 10. Plug, packing | 20. Valve seat | 30. Body |

Figure 5-4. Control valve, disassembly and reassembly.

b. Repair.

- (1) Replace all packing in the control valve.
- (2) Repair is made by replacement.

5-13. Control Valves Reassembly and Installation

a. Reassembly. Reassemble the control valves in reverse of disassembly, see figure 5-4.

b. Installation. Screw the two grease control valves into two grease lubricant reels, see TM 5-4930-207-12.

Section V. LUBRICATING UNIT PUMPS**5-14. General**

The air powered pumps are mounted opposite the hose reel assembly. A 40 to 1 ratio pump is mounted on the center lubricant container and one 12 to 1 ratio pump is mounted on each of the two outside lubricant containers. The pumps are heavy duty, reciprocating, industrial type pumps. Two hand meters are attached to hoses from the two 12 to 1 ratio pumps for dispensing gear and motor oil and two control valves are attached to the hose from the 40 to 1 ratio pump for dispensing grease.

5-15. Lubricating Unit Pumps Removal and Disassembly

a. Removal. Remove the lubricant pumps as instructed in TM 5-4930-207-12.

b. Disassembly.

- (1) Unscrew plug and insert assembly (1 and 2, fig. 5-5) and O-ring (3) from body (32).
- (2) Unscrew four screws (4) and remove adapter (5) with the O-ring (6) from valve body.
- (3) Move piston trip rod assembly (44, fig. 5-5) to the up position as shown in figure 5-6.

NOTE

A liquid sealant is applied to the threads of rod (44, fig. 5-5) to hold nuts (7 and 39) securely. Special precautions must be observed therefore when disassembling and reassembling these parts.

(4) Place a 3/8 inch open end wrench on the flats of the nut marked A in figure 5-6.

(5) Cover the rod with cloth and insert a slip joint pliers through adapter opening and grasp trip rod assembly above the shoulder at point marked B.

CAUTION

Do not scratch the chrome finish on trip rod assembly.

(6) Turn the 3/8 inch open end wrench counterclockwise and remove nut (7, fig. 5-5) from the trip rod assembly (44).

(7) Disassemble as illustrated in numerical sequence in figure 5-5 through 5-8.

5-16. Lubricating Unit Pumps Inspection and Repair*a. Inspection.*

- (1) Inspect rods for bends or other damage.
- (2) Inspect threads for wear or damage.
- (3) Inspect springs for distortion or fatigue.
- (4) Inspect housing for cracks and other damage.

b. Repair.

- (1) Repair is performed by replacement.
- (2) Replace all parts supplied in parts kits.

5-17. Lubricating Unit Pumps Reassembly and Installation*a. Reassembly.*

(1) Refer to figures 5-5 through 5-8 and reassemble in reverse of disassembly.

(2) Clean threads of trip rod (44, fig. 5-5), thoroughly before applying liquid sealant.

(3) Apply liquid sealant to threads of trip rod (44) from which nuts have been removed.

(4) Reassemble trip rod with slip joint pliers and 3/8 inch open end wrench.

(5) When a new slide (19,22) is installed in the air motor, the parts should be assembled with the letter "T" in the up position.

b. Installation. Refer to TM 54930-207-12 and install as instructed.

NOTE: ITEM 10 IS ON THE HIGH PRESSURE LUBRICANT PUMP MOTOR ONLY.

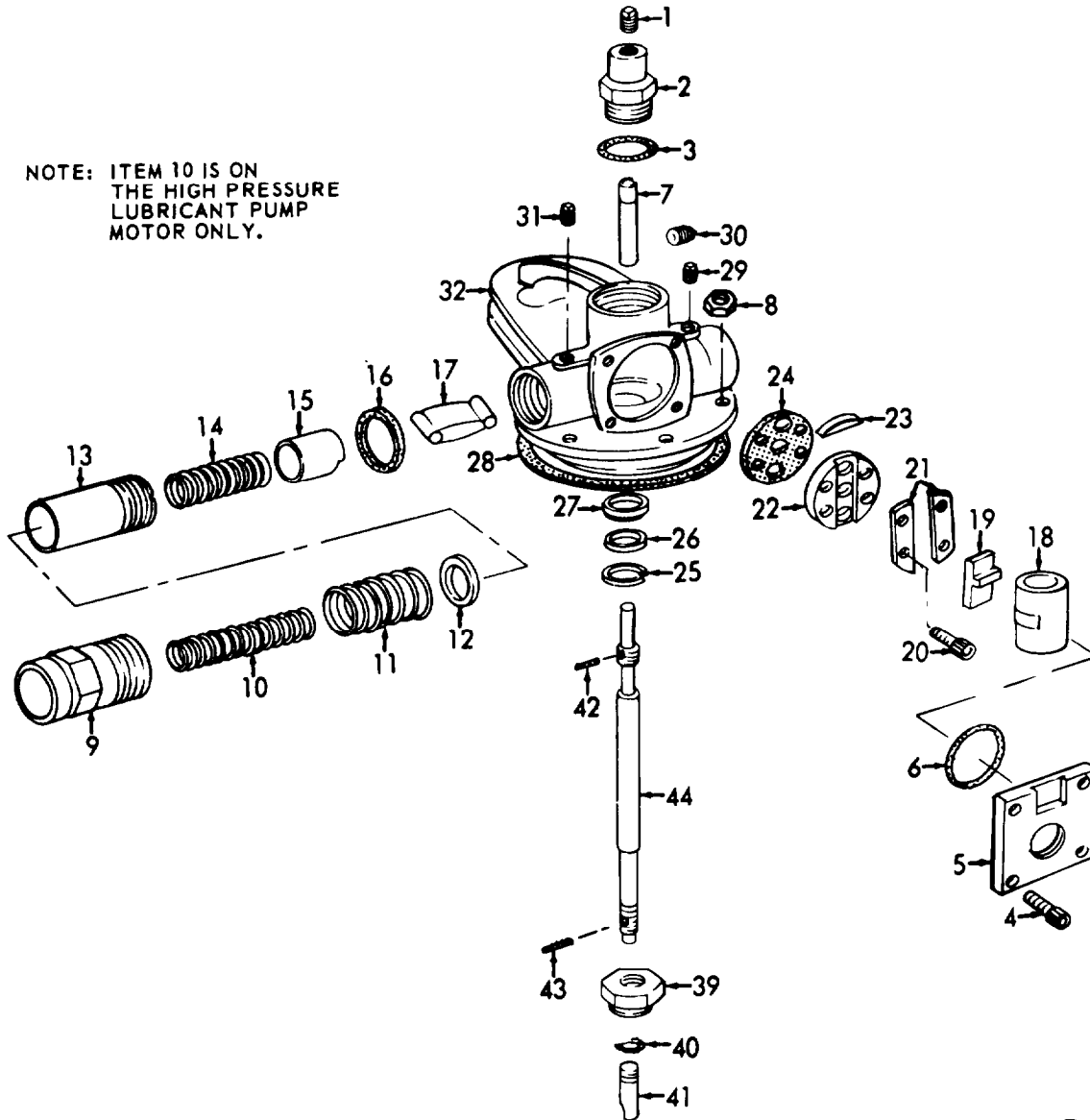

ME 4930-207-34/5-5 (1)

- | | | |
|--------------|---------------|-------------------|
| 1. Plug | 14. Spring | 27. Block |
| 2. Plug | 15. Plunger | 28. Packing |
| 3. Packing | 16. Gasket | 29. Screw |
| 4. Screw (4) | 17. Toggle | 30. Plug |
| 5. Adapter | 18. Shuttle | 31. Screw |
| 6. Packing | 19. Slide | 32. Body |
| 7. Nut | 20. Screw (4) | 39. Retainer |
| 8. Nut (8) | 21. Guide | 40. Packing |
| 9. Cap | 22. Slide | 41. Guide |
| 10. Spring | 23. Stop | 42. Insert, nylon |
| 11. Spring | 24. Gasket | 43. Insert, nylon |
| 12. Washer | 25. Ring | 44. Rod |
| 13. Cylinder | 26. Washer | |

Figure 5-5. High and low pressure lubricant pump motor, disassembly and reassembly (Sheet 1 of 4).

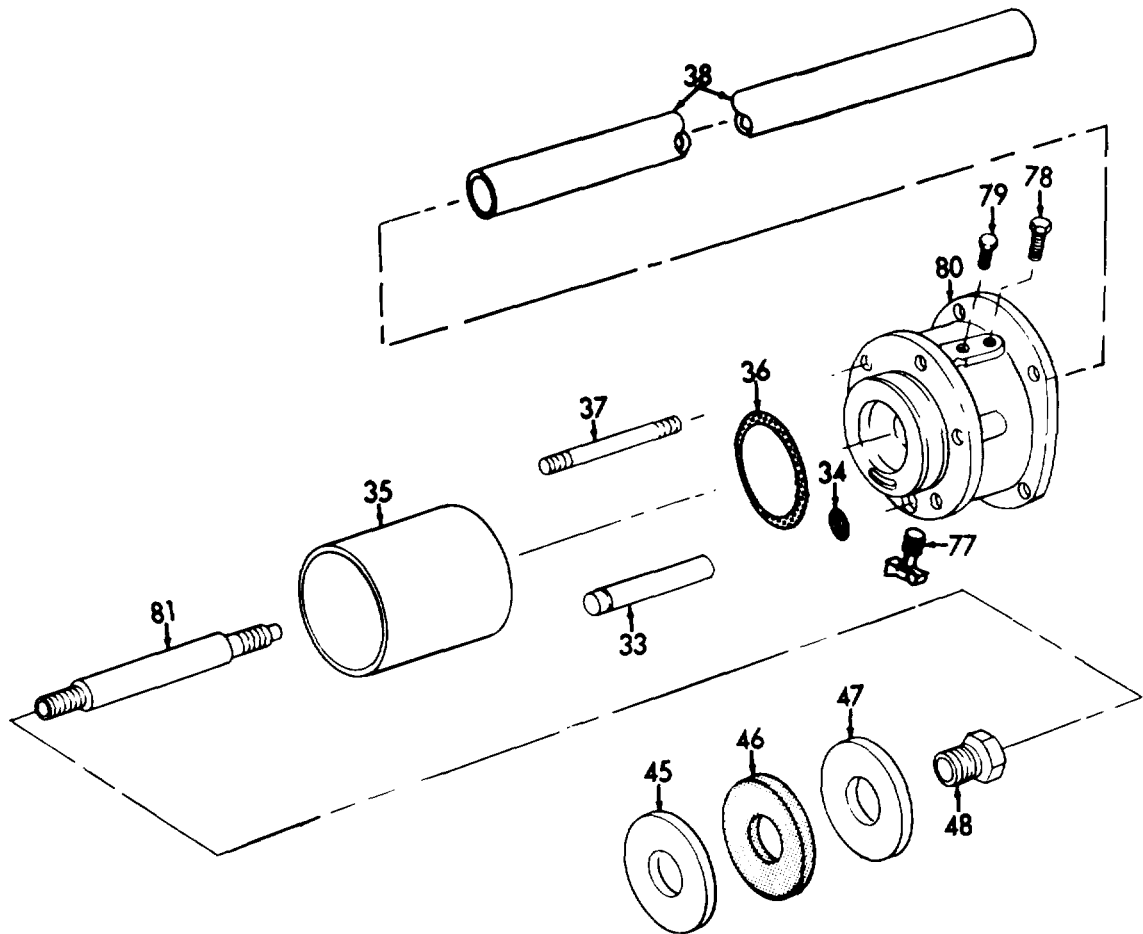

NOTE: TUBE (38) REPRESENTS BOTH THE LOW PRESSURE TUBE ASSEMBLY (FIG. 5-7) AND THE HIGH PRESSURE TUBE ASSEMBLY (FIG. 5-8).

- STEP 1. UNSCREW TUBE (38) FROM BOTTOM OF HEAD (80), TUBE (81) IS NOW EXPOSED. APPLY A WRENCH TO THE FLAT SURFACE TO REMOVE NUT (39).
- STEP 2. REMOVE NUT (48) FROM TUBE (81) AND SLIDE THE PRESSURE TUBE ASSEMBLY (FIG. 5-7 OR 5-8) FROM BOTTOM OF HEAD (80). THE TUBE (81) WILL COME OUT WITH THE ASSEMBLY.

ME 4930-207-34/5-5 (2)

- | | | |
|-----------------|-------------|-------------|
| 33. Tube | 38. Tube | 77. Petcock |
| 34. Packing (2) | 45. Washer | 78. Screw |
| 35. Cylinder | 46. Packing | 79. Screw |
| 36. Packing | 47. Washer | 80. Head |
| 37. Rod (6) | 48. Nut | 81. Tube |

Figure 5-5. High and low pressure lubricant pump motor, disassembly and reassembly (Sheet 2 of 4).

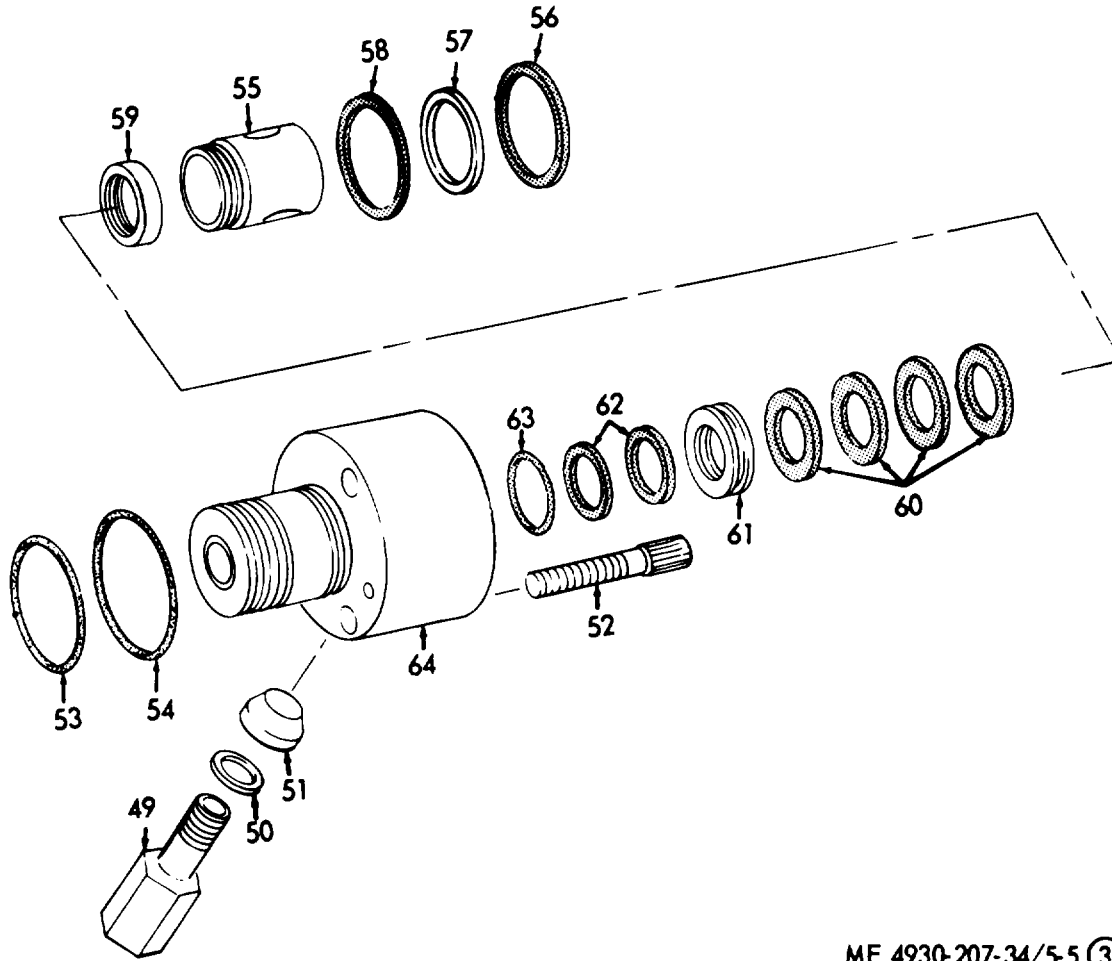

ME 4930-207-34/5-5 (3)

- 49. Adapter
- 50. Washer
- 51. Bushing
- 52. Screw (3)
- 53. Packing
- 54. Packing

- 55. Spacer
- 56. Gasket
- 57. Washer
- 58. Gasket
- 59. Bearing

- 60. Packing
- 61. Ring
- 62. Packing
- 63. Packing
- 64. Body

Figure 5-5. High and low pressure lubricant pump motor, disassembly and reassembly (Sheet 3 of 4).

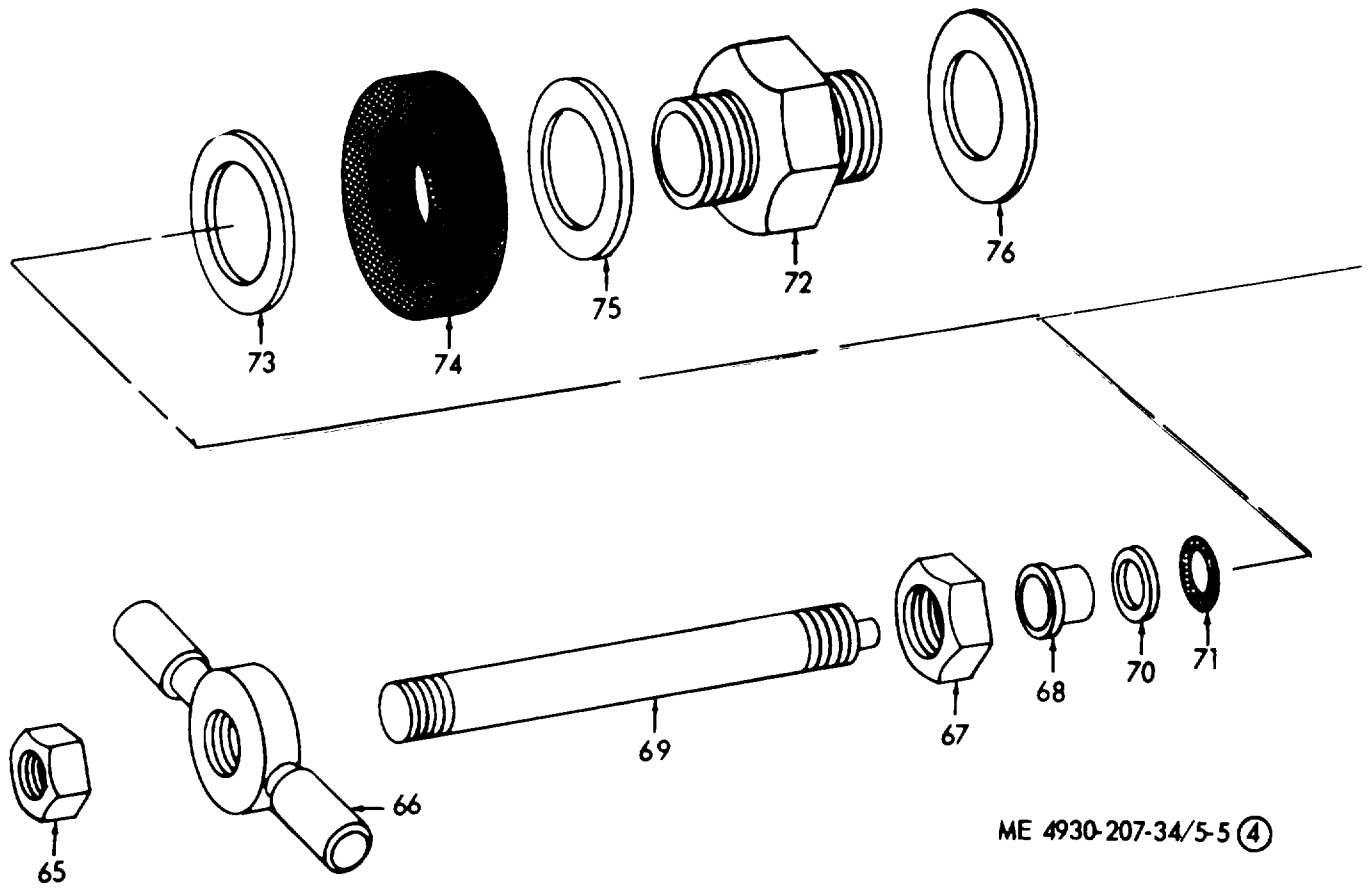

- 65. Nut
- 66. Handle
- 67. Nut
- 68. Bushing

- 69. Stem
- 70. Washer
- 71. Packing
- 72. Cap

- 73. Washer
- 74. Packing
- 75. Washer
- 76. Washer

Figure 5-5. High and low pressure lubricant pump motor, disassembly and reassembly (Sheet 4 of 4).

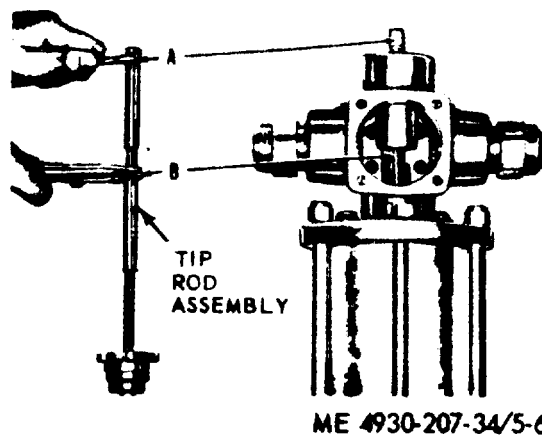
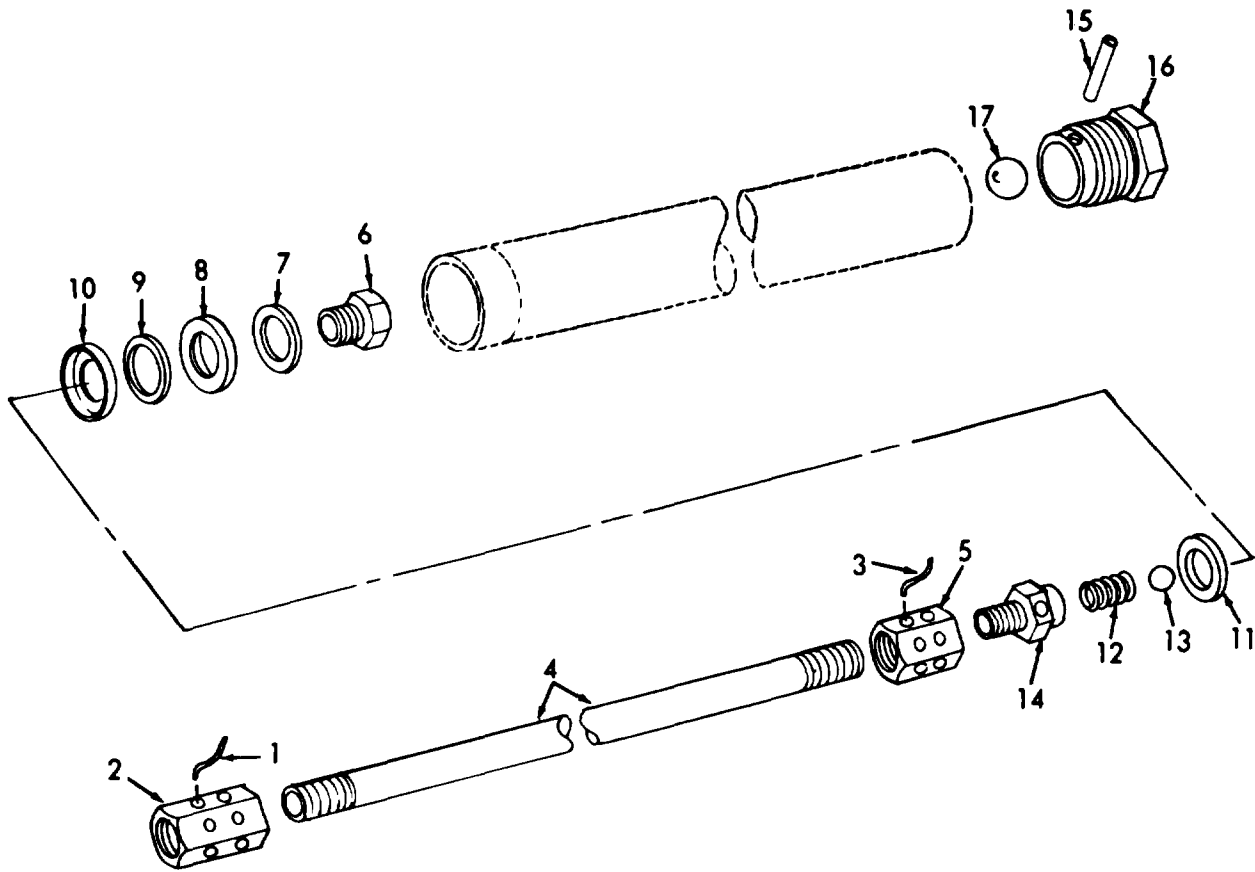

Figure 5-6. Removing nut from piston rod of lubricant pump.



ME 4930-207-34/5-7

- | | | |
|-------------|------------|------------------|
| 1. Clip | 7. Washer | 13. Ball bearing |
| 2. Coupling | 8. Cup | 14. Adapter |
| 3. Clip | 9. Plate | 15. Pin |
| 4. Rod | 10. Cup | 16. Body |
| 5. Coupling | 11. Washer | 17. Ball |
| 6. Seat | 12. Spring | |

Figure 5-7. Low pressure tube, disassembly and reassembly.

- | | | |
|-------------|-------------|-------------|
| 1. Clip | 10. Spring | 19. Body |
| 2. Coupling | 11. Ball | 20. Seat |
| 3. Clip | 12. Rod | 21. Spacer |
| 4. Rod | 13. Washer | 22. Plate |
| 5. Coupling | 14. Pin | 23. Nut |
| 6. Piston | 15. Adapter | 24. Rod |
| 7. Spacer | 16. Washer | 25. Body |
| 8. Spacer | 17. Screw | 26. Adapter |
| 9. Retainer | 18. Packing | |

Key to-Figure 5-8. High pressure tube, disassembly and reassembly.

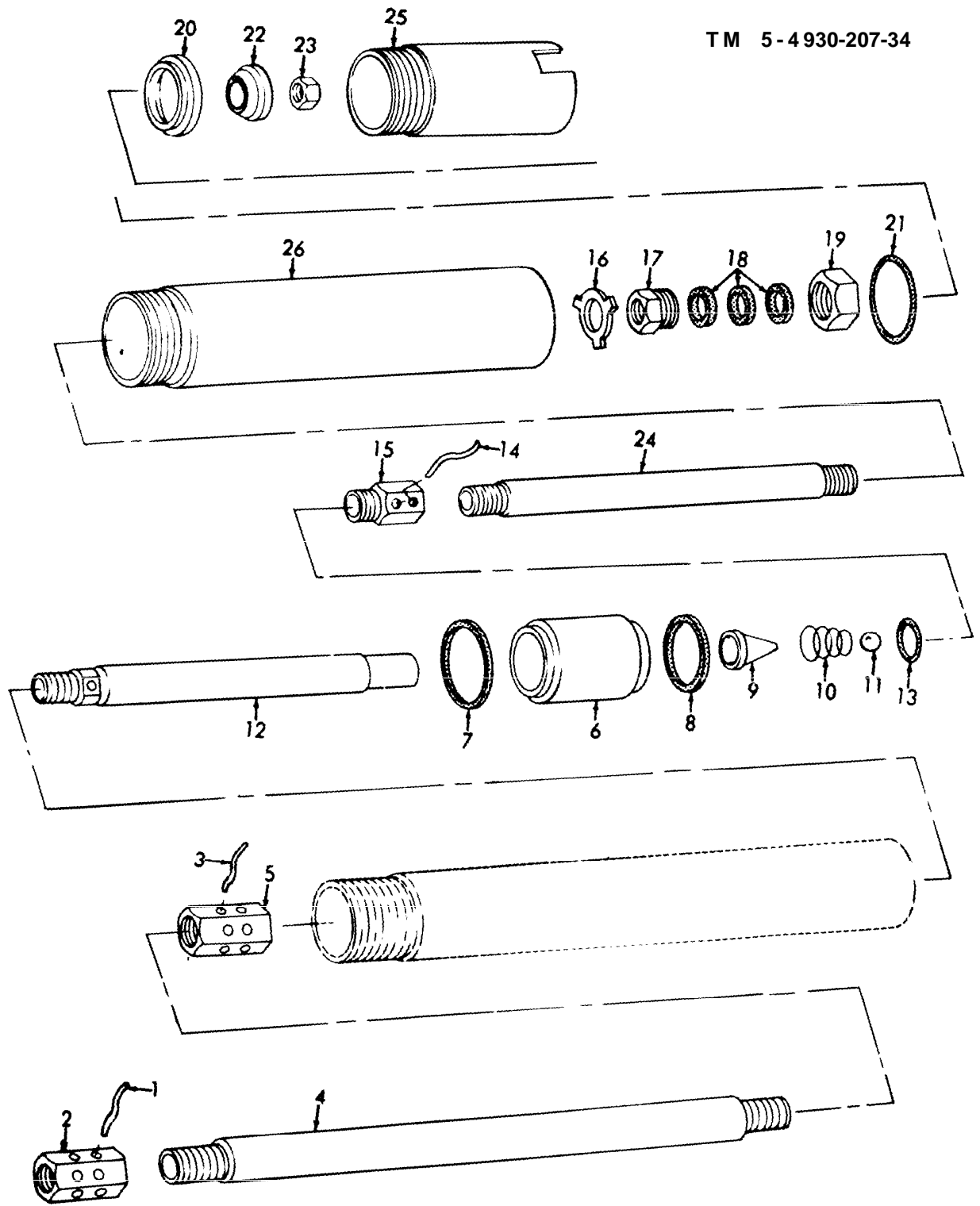

Figure 5-8. High pressure tube, disassembly and reassembly.

ME 4930-207-34/5-8

Section VI. TRANSFER PUMP

5-18. General

The transfer pump is an air operated device used for transferring lubricants from original drums to the lubricant tanks.

5-19. Transfer Pump Removal and Disassembly

a. Removal. Refer to TM 6-4930-207-12 for removal instructions.

b. Disassembly. Refer to figure 5-9 and disassemble the transfer pump in numerical sequence as illustrated.

5-20. Transfer Pump Inspection and Repair

a. Inspection.

(1) Inspect base valve (9) to see if it is free from dirt and foreign matter.

(2) Inspect washer (18) to see if clean and it fluctuates easily when reassembled.

(3) Inspect two packings (10) for wear or damage.

(4) Inspect all threaded surfaces for scratches, burrs, or wear.

(5) Inspect pump rods and tubes for bends, breaks, or other damage.

b. Repair. Repair is made by replacement,

5-21. Transfer Pump Reassembly and Installation

a. Reassembly. Refer to figure 5-9 and reassemble in reverse order of removal.

b. Installation. Refer to TM 5-4930-207-12 and install the transfer pump as instructed.

- | | | |
|-----------------|---------------------------|---------------------|
| 1. Adapter | 17. Plunger | 33. Piston assembly |
| 2. Valve | 18. Washer | 34. Washer |
| 3. Adapter | 19. Rod and stop assembly | 35. Washer |
| 4. Thumbscrew | 20. Pump casting | 36. Spring |
| 5. Bung adapter | 21. Ring | 37. Spacer |
| 6. Hose and cap | 22. Packing | 38. Stopnut (3) |
| 7. Bushing | 23. Ring | 39. Screw (3) |
| 8. Cylinder | 24. Bushing | 40. Gasket (3) |
| 9. Valve base | 25. Packing | 41. Spacer (3) |
| 10. Packing (2) | 26. Adapter assembly | 42. Seal plate |
| 11. Nut | 27. Washer | 43. Adapter |
| 12. Washer | 28. Packing | 44. Washer |
| 13. Stud | 29. Cylinder assembly cap | 45. Packing |
| 14. Washer | 30. Spring | 46. Washer |
| 15. Pin | 31. Cylinder assembly | 47. Washer |
| 16. Stopnut | 32. Adapter assembly | |

Key to-Figure 5-9. Transfer pump, disassembly and reassembly.

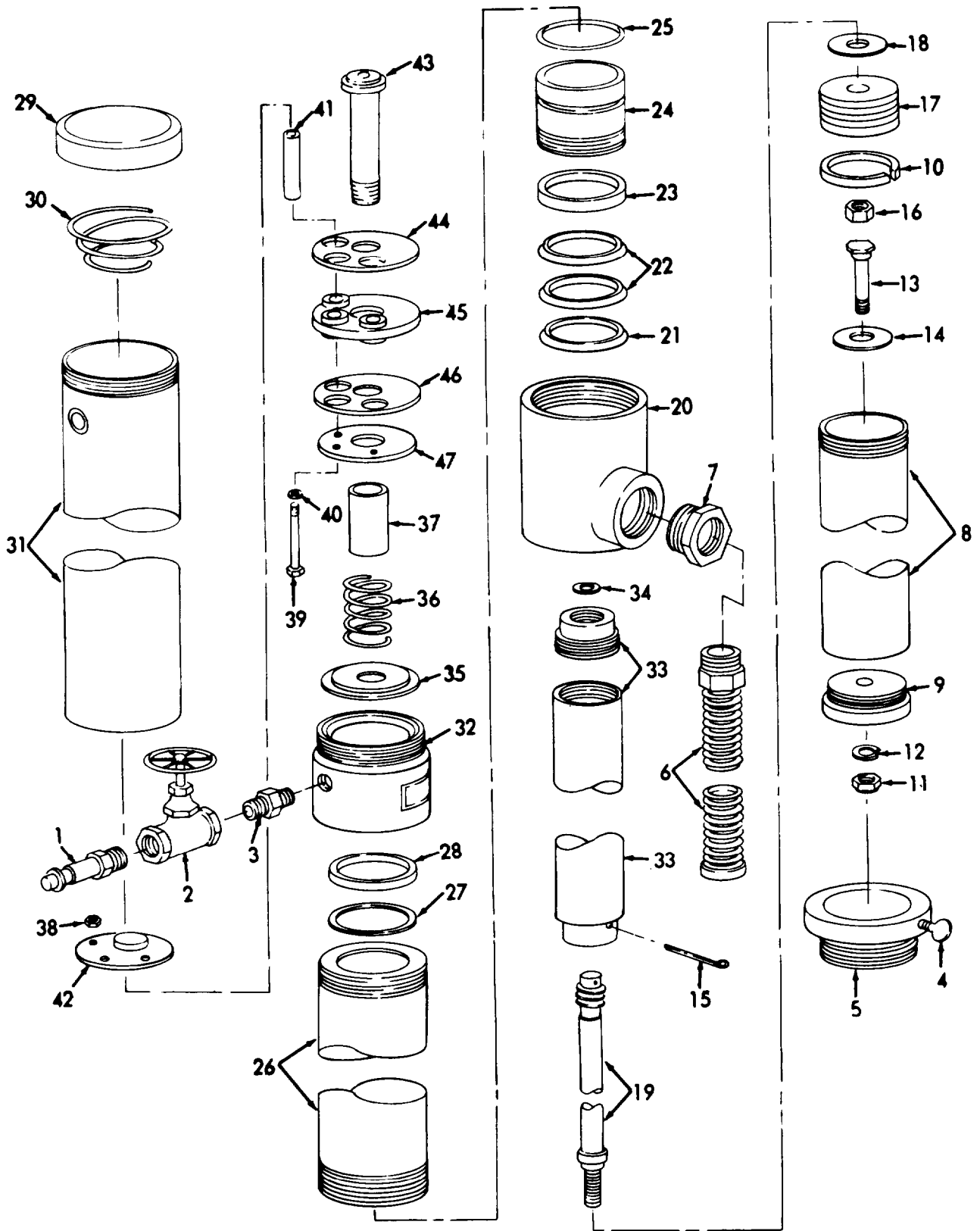

ME 4930-207-34/5-9

Figure 5-9. Transfer pump. disassembly and reassembly.

Section VII. SKID BASE

5-22. Skid Base Removal

a. *Components.* For removal of engine assembly, compressor assembly, three lubricating pumps, reel bank assembly, alcohol injector assembly, and control panel assembly refer to TM 5-4930-207-12.

b. *Skid base.* Remove 6 screws, washers, and nuts that attach the skid base to the trailer frame. Remove skid base from trailer (TM 5-4930-207-12).

5-23. Skid Base Inspection and Repair

a. *Inspection.* Inspect the skid base for excessive dents or broken welds.

b. *Repair.*

(1) Reweld a broken weld.

(2) Replace a skid base that is beyond repair.

5-24. Skid Base Installation

a. *Skid Base.* Install 6 screws, washers, and nuts securing the skid base to the trailer frame (TM 5-4930-207-12).

b. *Components.* Refer in TM 5-4930-207-12 and install the engine assembly, compressor assembly, three lubricating pumps, reel bank assembly, alcohol injector assembly, and control panel assembly.

CHAPTER 6

REPAIR OF TRAILER COMPONENTS

Section I. SERVICE BRAKES

6-1. General

The trailer service brakes are the scavenger type actuated by a diaphragm-type air chamber. Each brake has two wheel cylinders secured to the backing plate. The wheel cylinders are actuated hydraulically to give an equal pressure to all brakeshoes. The air relay valve controls the trailer brakes and automatically applies the trailer brakes in event the trailer separates from the towing vehicle.

6-2. Air Filters

a. *Removal.* Disconnect two lines from air filter, remove two nuts and U-bolt holding air filter

to trailer frame. Remove other air filter in a similar manner.

b. *Disassembly.* Refer to figure 6-1 for disassembly of air filter in numerical sequence.

c. *Inspection.*

(1) Inspect filter body for cracks, breaks, stripped threads, and other damage.

(2) Inspect spring for distortion or fatigue.

d. *Repair.*

(1) Repair is made by replacement.

(2) Replace parts supplied in kit.

e. *Reassembly.* Refer to figure 6-1 and reassemble the air filter in reverse of removal.

f. *Installation.* Refer to TM 5-4930-207-12 for correct installation of air filter.

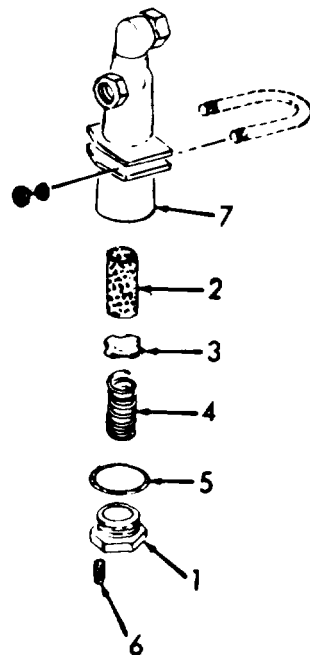

ME 4930-207-34/6-1

1. Adapter
2. Element
3. Washer
4. Spring

5. Washer
6. Plug
7. Body

Figure 6-1. Air filter, disassembly and reassembly.

6-3. Hydraulic Master Cylinder

a. *Removal.* TM 5-4930-207-12 provides removal instructions for the hydraulic master cylinder.

b. *Disassembly.* Refer to figure 6-2 and disassemble the hydraulic master cylinder in numerical sequence,

c. *Inspection.*

(1) Inspect body for dents, stripped threads, and other damage.

(2) Inspect spring for distortion or fatigue.

d. *Repair.* Replace defective parts.

e. *Reassemble.* Refer to figure 6-2 and reassemble the hydraulic master cylinder.

f. *Installation.* Refer to TM 5-4930-207-12 and install the hydraulic master cylinder.

6-4. Brakeshoes and Linings

a. *Removal.* Refer to TM 5-4930-207-12 and remove the brakeshoes.

b. *Disassembly.* Disassemble the brakeshoe as illustrated in numerical sequence in figure 6-3.

c. *Inspection.*

(1) Inspect the brakeshoes for cracks and breaks.

(2) Inspect linings for wear and evidence of grease or hydraulic fluid having penetrated the linings.

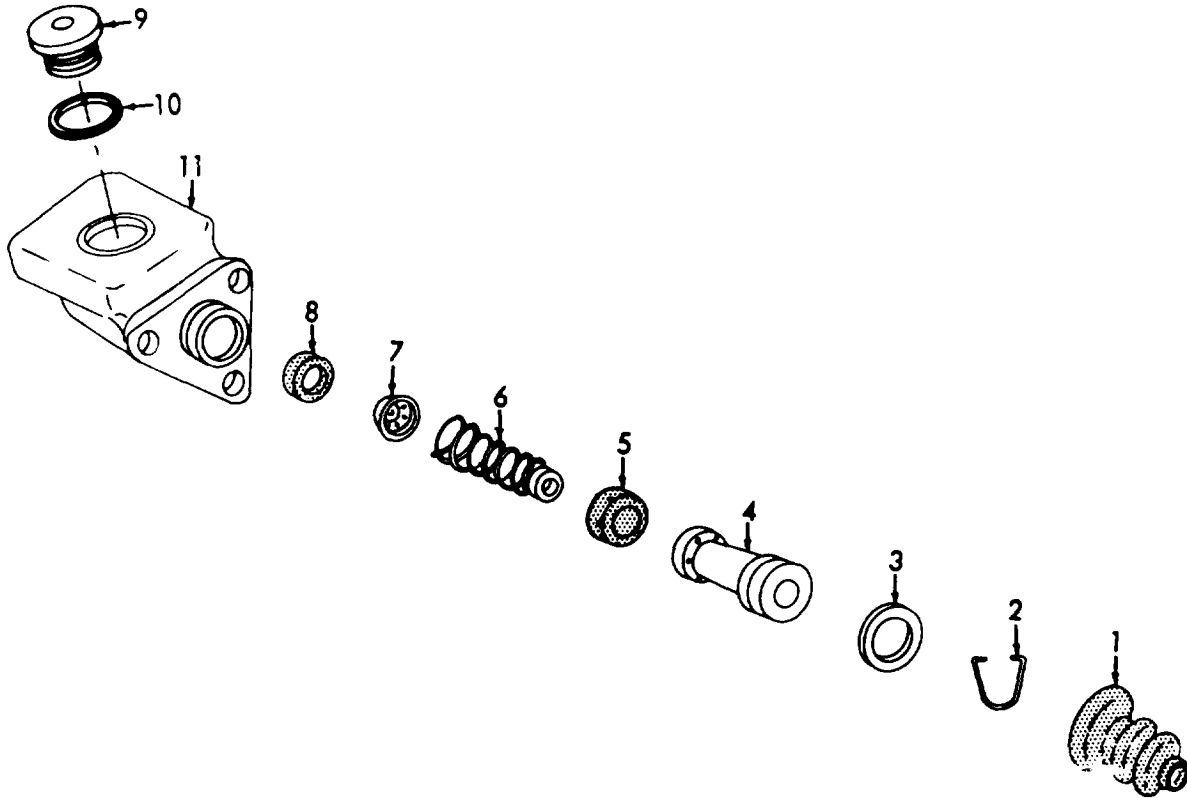

ME 4930-207-34/6-2

- 1. Boot
- 2. Ring
- 3. Washer
- 4. Piston

- 5. Cup
- 6. Spring
- 7. Valve
- 8. Seat

- 9. Cap
- 10. Washer
- 11. Body

Figure 6-2 Hydraulic master cylinder, disassembly and reassembly.

d. *Repair.* Replace all defective parts.

e. *Reassembly.* Refer to figure 6-3 and reassemble the brakeshoe.

f. *Installation.* Install the brakeshoes as instructed in TM 5-4930-207-12.

6-5 Wheel Cylinders

a. *Removal.* Remove the wheel cylinders as instructed in TM 5-4930-207-12.

b. *Disassembly.* Refer to figure 6-4 and disassemble the wheel cylinder in numerical sequence.

c. *Inspection.*

(1) Inspect the inside of cylinder for pits, scratches, and rust.

(2) Inspect spring for distortion or fatigue.

d. *Repair.* Replace damaged or defective parts,

e. *Reassembly.* Refer to figure 6-4 and reassemble the wheel cylinders.

f. *Installation.* Installation of wheel cylinders is given in TM 5-4930-207-12.

6-6. Backplate

a. *Removal.*

(1) Remove brakeshoes and wheel cylinders as instructed in TM 5-4930-207-12.

(2) Refer to figure 6-5 and remove backplate.

b. *Cleaning and Inspection.*

(1) Clean backplate and dry thoroughly.

(2) Inspect for cracks, breaks, and other damage, replace a defective backplate.

c. *Installation.*

(1) Refer to figure 6-5 and install the backplate.

(2) Install brakeshoes and wheel cylinders as instructed in TM 5-4930-207-12.

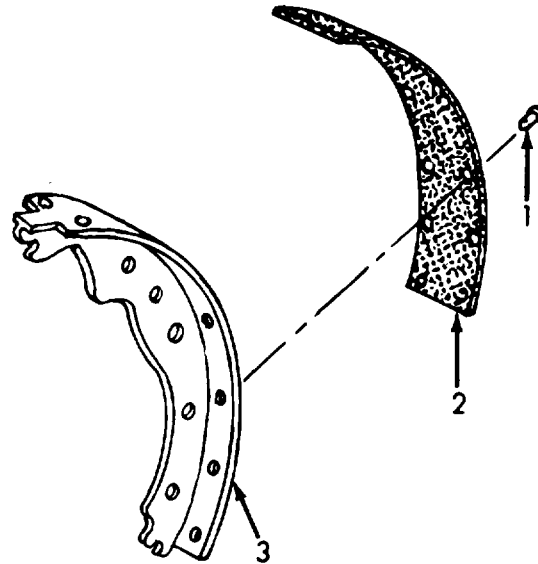

ME 4930-207-34/6-3

- 1. Rivet (56)
- 2. Lining (4)
- 3. Brakeshoe (4)

Figure 6-3. Brakeshoe, disassembly and reassembly.

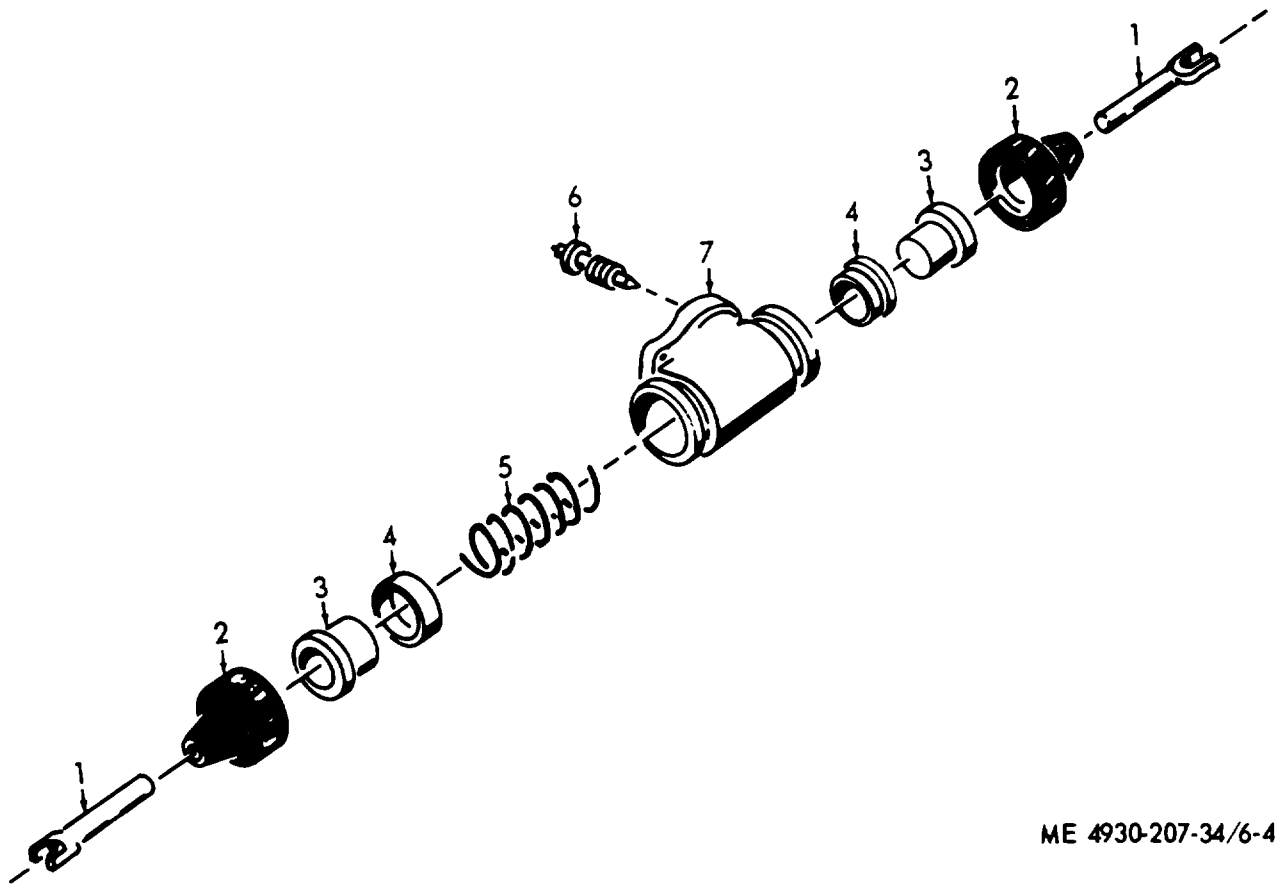

ME 4930-207-34/6-4

- 1. Link
- 2. Boot
- 3. Piston
- 4. Ring
- 5. Spring
- 6. Bleeder valve
- 7. Cylinder body

Figure 6-4. Wheel cylinder, disassembly and reassembly.

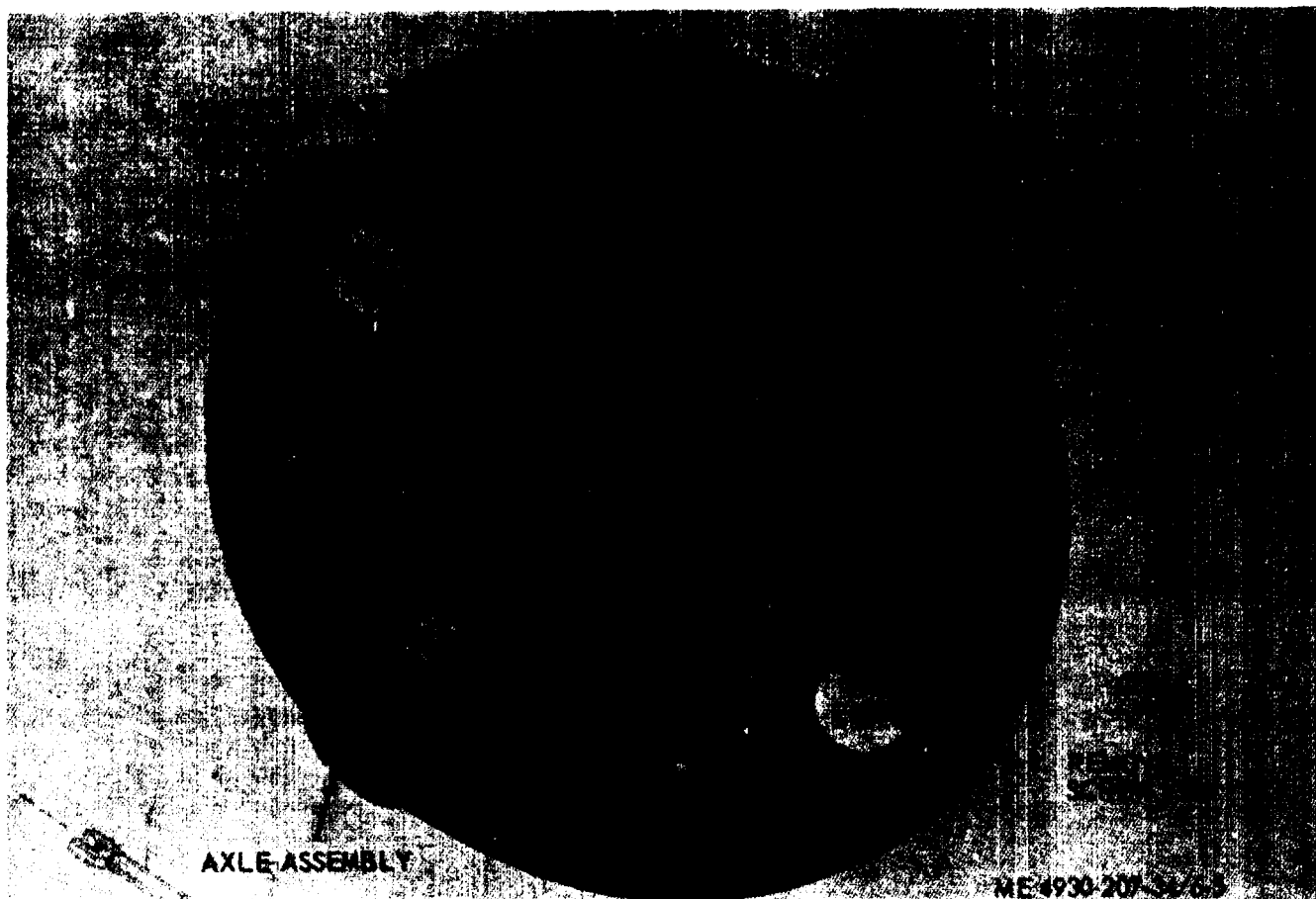

Figure 6-5. Backplate, removal and installation.

Section II. AXLE ASSEMBLY

6-7. General

The trailer axle is a welded assembly consisting of an axle tube and a tie beam connecting the axle tube with a stub axle on which the wheels are mounted. The axle tube is mounted to the trailer frame with two bearings, one on each side of the trailer frame. A shock absorber mounting link is welded to each end of the axle tube.

6-8. Axle Assembly

a. Removal.

(1) To remove the axle assembly refer to TM 5-4930-207-12 to remove the shock absorbers, springs, and brake assemblies.

(2) Refer to figure 6-6 and remove the axle assembly.

b. Inspection.

(1) Inspect axle for bends, broken welds, and worn bearing journals.

(2) Inspect bearings for excessive wear.

c. Repair.

(1) Replace a defective axle assembly.

(2) Replace damaged or defective mounting hardware and lubrication fittings.

d. Installation.

(1) Refer to figure 6-6 and install the axle assembly.

(2) Install the brake assemblies, springs, and shock absorbers as instructed in TM 5-4930-207-12.



Figure 6-6. Axle assembly, removal and installation.

Section III. TRAILER FRAME

6-9. General

The trailer frame is an all steel-welded construction consisting of two parallel frame rails with crossmembers between the rails. The frame has a landing gear bracket, spring hanger bracket, hand lifting bars, lashing rings, and two upper halves of the bearing housing welded to it.

6-10. Trailer Frame

a. *Removal.* Refer to TM 5-4930-207-12 to remove items as follows:

- (1) Reflectors, clearance lights, taillights, and blackout lights.
- (2) Lunette
- (3) Brake hydraulic system tubing.
- (4) Brake air system tubing.

- (5) Brakes and wheel cylinders,
- (6) Brake valve.
- (7) Air reservoir.
- (8) Landing gear.
- (9) Shock absorber.
- (10) Springs
- (11) Axle assembly

b. *Inspection and Repair.*

- (1) Inspect trailer frame for cracks, breaks, broken welds, and other damage.
- (2) Straighten minor bends and reweld broken welds. Replace a frame which is damaged beyond repair.

c. *Installation.* Install in reverse order of removal. Refer to TM 5-4930-207-12,

APPENDIX A

REFERENCES

A-1. Fire Protection

TB 5-4200-200-10 Hand Portable Fire Extinguishers Approved for Army Users

A-2. Lubrication

LO 5-2805-203-12 Engine, Gasoline, Model 4A032-11

LO 5-4930-207-12 Lubricating and Servicing Unit

A-3. Painting

TM 9-213 Painting Instructions for Field Use

A-4. Maintenance

TM 5-764 Electric Motor and Generator Repair

TM 5-2805-203-14 Operator, Organizational, DS, and GS Maintenance Manual, Engine Gasoline Military Standard Models (Model 4A032-1; Model 4A032-11)

TM 5-2805 203-24P Organizational, DS and GS Maintenance Repair Parts and Special Tools List, Engine Gasoline Military Standard Models (Model 4A032-1; Model 4A032-11)

TM 5-4930-207-12 Operator and Organizational Maintenance Manual

TM 5-4930-207-20P Organizational Maintenance Repair Parts and Special Tools List

TM 5-4930-207-35P Direct Support, General Support and Depot Maintenance Repair Parts and Special Tools List

TM 9-1870-1 Care and Maintenance of Pneumatic Tires

TM 9-6140-200-15 Operation and Organizational Field and Depot Maintenance Storage Batteries, Lead-Acid Type

TM 38-750 Army Equipment Record Procedures

A-5, Shipment and Storage

TB 740-90-1 Administrative Storage of Equipment

TB 740-93-2 Preservation of USAMEC Mechanical Equipment for Shipment and Storage.

ALPHABETICAL INDEX

<i>.Subject</i>	<i>Paragraph, Figure, Table Number</i>
A	
Air filter	6-2
Air receiver:	
General	5-1
Removal and installation.....	5-2
Axle assembly.....	6-7
B	
Backplate	6-6
Base, Skid:	
Removal	5-22
Inspection and repair.....	5-23
Installation.....	5-24
Brakes	6-1
Brakeshoes and linings.....	6-4
C	
Centrifugal Unloader:	
General	4-9
Removal and disassembly.....	4-10
Inspection and repair	4-11
Reassembly and installation	4-12
Control Valve:	
General	5-10
Removal and disassembly	5-11
Inspection and repair	5-12
Reassembly and installation.....	5-13
Crankcase and crankshaft:	
General	4-13
Removal and disassembly	4-14
Cleaning	4-16
Inspection and repair	4-16
Reassembly and installation.....	4-17
Cylinder and pistons:	
General	4-5
Removal and disassembly.....	4-6
Cleaning and inspection	4-7
Reassembly and installation.....	4-8
Cylinder head valves and intercooler:	
General	4-1
Removal and disassembly.....	4-2
Inspection and repair	4-3
Reassembly and installation.....	4-4
D	
Data, tabulated	1-5
Description	1-3
Differences between models	1-4

Subject		
	E	
Equipment and tools -----		2-1
	F	
Filter, Air -----		6-2
Forms and records -----		1-2
Frame, trailer -----		6-9
	G	
Generator -----		3-1
	H	
Hose Reel:		
Removal and disassembly -----		5-3
Inspection and repair -----		5-4
Reassembly and installation -----		6-6
Hydraulic master cylinder-----		6-3
	I	
Intercooler:		
General -----		4-1
Removal and disassembly -----		4-2
Inspection and repair -----		4-3
Reassembly and installation -----		4-4
	L	
Linings and Brakeshoes-----		6-4
Lubricating pumps; (high pressure (40 to 1 ratio, grease) and low pressure (12 to 1 ratio, oil)):		
General -----		5-14
Removal and disassembly -----		5-15
Inspection and repair -----		5-16
Reassembly and installation -----		5-17
	M	
Maintenance repair parts -----		2-3
Master cylinder -----		6-3
Meters: (gear hand (pints) and motor hand (quarts)):		
General -----		5-6
Removal and disassembly-----		5-7
Cleaning, inspection, and repair -----		5-8
Reassembly and installation -----		5-9
Models, difference between-----		1-4
	P	
Pistons:		
General -----		4-5
Removal and disassembly -----		4-6
Cleaning and inspection -----		4-7
Reassembly and installation -----		4-8
Polarizing the generator -----		3-1
Pumps, lubricating unit, (high pressure (40 to 1 ratio, grease) and low pressure (12 to 1 ratio, oil)):		
General -----		5-14
Removal and disassembly -----		5-15
Inspection and repair -----		5-16
Reassembly and installation -----		5-17

<i>Subject</i>	<i>Paragraph, Figure, Table Number</i>
Pump transfer:	
General-----	5-18
Removal and disassembly -----	5-19
Inspection and repair-----	5-20
Reassembly and installation-----	5-21
R	
Receiver, air:	
General -----	5-1
Removal and installation -----	5-2
Records and forms -----	1-2
Reel hone:	
Removal and disassembly-----	5-3
Inspection and repair -----	5-4
Reassembly and installation-----	5-5
Repair parts, maintenance -----	2-3
Requirements and standards:	
Clearance and fitting requirements -----	T1-1
Piston and ring repair standards -----	F1-1
S	
Service brakes-----	6-1
Skid base:	
Removal-----	5-22
Inspection and repair -----	5-23
Installation -----	5-24
Special tools and equipment-----	2-2
Starter -----	3-3
T	
Tabulated data -----	1-5
Testing:	
Generator -----	3-1
Starter -----	3-3
Tools and equipment -----	2-1
Trailer frame -----	6-9
Transfer pump:	
General -----	5-18
Removal and disassembly -----	5-19
Inspection and repair -----	5-20
Reassembly and installation -----	5-21
Troubleshooting -----	T2-1
U	
Unloader, centrifugal:	
General -----	4-9
Removal and disassembly -----	4-10
Inspection and repair -----	4-11
Reassembly and installation -----	4-12
V	
Valve, control:	
General -----	5-10
Removal and disassembly -----	5-11
Inspection and repair -----	5-12
Reassembly and installation -----	5-13
Valves, cylinder head and intercooler:	
General -----	4-1
Removal and disassembly -----	4-2
Inspection and repair -----	4-3
Reassembly and installation -----	4-4
Control -----	5-10
Cylinder head -----	4-1
W	
Wheel cylinders -----	6-5

TM 5-4930-207-34

By Order of the Secretary of the *Army*:

Official:

KENNETH G. WICKHAM
Major General, United States Army,
The Adjutant General.

W. C. WESTMORELAND,
General, United States Army,
Chief of Staff.

Distribution:

To be distributed in accordance with DA Form 12-25, Section I, (qty rqr block no, 139) Direct and General Support maintenance requirements for Lubricating and Servicing Equipment.

RECOMMENDED CHANGES TO EQUIPMENT TECHNICAL PUBLICATIONS



THEN...JOT DOWN THE
DOPE ABOUT IT ON THIS FORM.
CAREFULLY TEAR IT OUT, FOLD IT
AND DROP IT IN THE MAIL.

SOMETHING WRONG WITH PUBLICATION

FROM: (PRINT YOUR UNIT'S COMPLETE ADDRESS)

DATE SENT

PUBLICATION NUMBER

PUBLICATION DATE

PUBLICATION TITLE

BE EXACT PIN-POINT WHERE IT IS

PAGE
NO.

PARA-
GRAPH

FIGURE
NO.

TABLE
NO.

IN THIS SPACE, TELL WHAT IS WRONG
AND WHAT SHOULD BE DONE ABOUT IT.

TEAR ALONG PERFORATED LINE

PRINTED NAME, GRADE OR TITLE AND TELEPHONE NUMBER

SIGN HERE

The Metric System and Equivalents

Linear Measure

1 centimeter = 10 millimeters = .39 inch
 1 decimeter = 10 centimeters = 3.94 inches
 1 meter = 10 decimeters = 39.37 inches
 1 dekameter = 10 meters = 32.8 feet
 1 hectometer = 10 dekameters = 328.08 feet
 1 kilometer = 10 hectometers = 3,280.8 feet

Weights

1 centigram = 10 milligrams = .15 grain
 1 decigram = 10 centigrams = 1.54 grains
 1 gram = 10 decigrams = .035 ounce
 1 dekagram = 10 grams = .35 ounce
 1 hectogram = 10 dekagrams = 3.52 ounces
 1 kilogram = 10 hectograms = 2.2 pounds
 1 quintal = 100 kilograms = 220.46 pounds
 1 metric ton = 10 quintals = 1.1 short tons

Liquid Measure

1 centiliter = 10 milliliters = .34 fl. ounce
 1 deciliter = 10 centiliters = 3.38 fl. ounces
 1 liter = 10 deciliters = 33.81 fl. ounces
 1 dekaliter = 10 liters = 2.64 gallons
 1 hectoliter = 10 dekaliters = 26.42 gallons
 1 kiloliter = 10 hectoliters = 264.18 gallons

Square Measure

1 sq. centimeter = 100 sq. millimeters = .155 sq. inch
 1 sq. decimeter = 100 sq. centimeters = 15.5 sq. inches
 1 sq. meter (centare) = 100 sq. decimeters = 10.76 sq. feet
 1 sq. dekameter (are) = 100 sq. meters = 1,076.4 sq. feet
 1 sq. hectometer (hectare) = 100 sq. dekameters = 2.47 acres
 1 sq. kilometer = 100 sq. hectometers = .386 sq. mile

Cubic Measure

1 cu. centimeter = 1000 cu. millimeters = .06 cu. inch
 1 cu. decimeter = 1000 cu. centimeters = 61.02 cu. inches
 1 cu. meter = 1000 cu. decimeters = 35.31 cu. feet

Approximate Conversion Factors

To change	To	Multiply by	To change	To	Multiply by
inches	centimeters	2.540	ounce-inches	newton-meters	.007062
feet	meters	.305	centimeters	inches	.394
yards	meters	.914	meters	feet	3.280
miles	kilometers	1.609	meters	yards	1.094
square inches	square centimeters	6.451	kilometers	miles	.621
square feet	square meters	.093	square centimeters	square inches	.155
square yards	square meters	.836	square meters	square feet	10.764
square miles	square kilometers	2.590	square meters	square yards	1.196
acres	square hectometers	.405	square kilometers	square miles	.386
cubic feet	cubic meters	.028	square hectometers	acres	2.471
cubic yards	cubic meters	.765	cubic meters	cubic feet	35.315
fluid ounces	milliliters	29.573	cubic meters	cubic yards	1.308
pints	liters	.473	milliliters	fluid ounces	.034
quarts	liters	.946	liters	pints	2.113
gallons	liters	3.785	liters	quarts	1.057
ounces	grams	28.349	liters	gallons	.264
pounds	kilograms	.454	grams	ounces	.035
short tons	metric tons	.907	kilograms	pounds	2.205
pound-feet	newton-meters	1.356	metric tons	short tons	1.102
pound-inches	newton-meters	.11296			

Temperature (Exact)

°F Fahrenheit temperature 5/9 (after subtracting 32) Celsius temperature °C

PIN: 005950-000